

(19) World Intellectual Property Organization
International Bureau



(43) International Publication Date
2 February 2012 (02.02.2012)

(10) International Publication Number
WO 2012/015907 A1

- (51) **International Patent Classification:**
A61B 17/11 (2006.01) A61B 1/00 (2006.01)
A61B 17/115 (2006.01)
- (21) **International Application Number:**
PCT/US2011/045517
- (22) **International Filing Date:**
27 July 2011 (27.07.2011)
- (25) **Filing Language:** English
- (26) **Publication Language:** English
- (30) **Priority Data:**
12/846,956 30 July 2010 (30.07.2010) US
- (71) **Applicant (for all designated States except US):**
ETHICON ENDO-SURGERY, INC. [US/US]; 4545
Creek Road, Cincinnati, OH 45242 (US).
- (72) **Inventors; and**
- (75) **Inventors/Applicants (for US only):** **SHELTON, IV, Frederick, E.** [US/US]; 245 E. Main Street, Hillsboro, OH 45153 (US). **WILLIS, John, W.** [US/US]; 5098 Palermo Road, Cincinnati, OH 45244 (US).
- (74) **Agents:** **JOHNSON, Philip, S.** et al.; JOHNSON & JOHNSON, 1 Johnson & Johnson Plaza, New Brunswick, NJ 08933 (US).

- (81) **Designated States (unless otherwise indicated, for every kind of national protection available):** AE, AG, AL, AM, AO, AT, AU, AZ, BA, BB, BG, BH, BR, BW, BY, BZ, CA, CH, CL, CN, CO, CR, CU, CZ, DE, DK, DM, DO, DZ, EC, EE, EG, ES, FI, GB, GD, GE, GH, GM, GT, HN, HR, HU, ID, IL, IN, IS, JP, KE, KG, KM, KN, KP, KR, KZ, LA, LC, LK, LR, LS, LT, LU, LY, MA, MD, ME, MG, MK, MN, MW, MX, MY, MZ, NA, NG, NI, NO, NZ, OM, PE, PG, PH, PL, PT, RO, RS, RU, SC, SD, SE, SG, SK, SL, SM, ST, SV, SY, TH, TJ, TM, TN, TR, TT, TZ, UA, UG, US, UZ, VC, VN, ZA, ZM, ZW.
- (84) **Designated States (unless otherwise indicated, for every kind of regional protection available):** ARIPO (BW, GH, GM, KE, LR, LS, MW, MZ, NA, SD, SL, SZ, TZ, UG, ZM, ZW), Eurasian (AM, AZ, BY, KG, KZ, MD, RU, TJ, TM), European (AL, AT, BE, BG, CH, CY, CZ, DE, DK, EE, ES, FI, FR, GB, GR, HR, HU, IE, IS, IT, LT, LU, LV, MC, MK, MT, NL, NO, PL, PT, RO, RS, SE, SI, SK, SM, TR), OAPI (BF, BJ, CF, CG, CI, CM, GA, GN, GQ, GW, ML, MR, NE, SN, TD, TG).

Declarations under Rule 4.17:

- as to the identity of the inventor (Rule 4.17(i))
- as to applicant's entitlement to apply for and be granted a patent (Rule 4.17(ii))
- as to the applicant's entitlement to claim the priority of the earlier application (Rule 4.17(iii))

[Continued on next page]

(54) **Title:** TRANSWALL VISUALIZATION ARRANGEMENTS FOR SURGICAL CIRCULAR STAPLERS

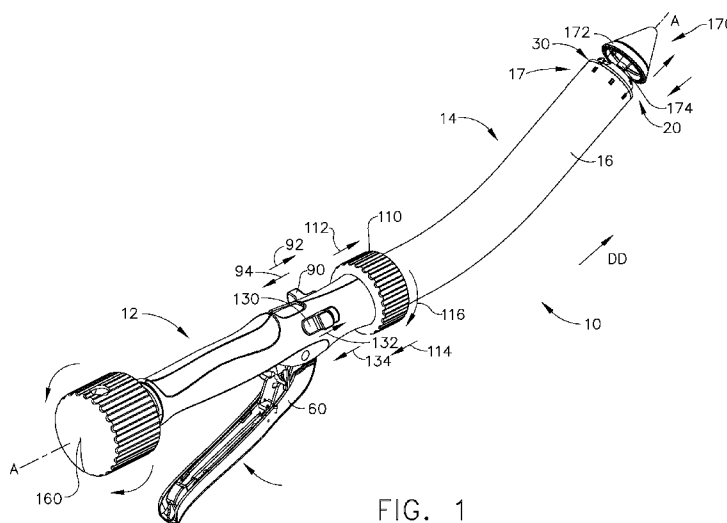

FIG. 1

(57) **Abstract:** A surgical instrument is disclosed. Various embodiments include an elongated shaft that defines a central axis and has a distal end portion that is configured to operably support a circular staple cartridge therein. At least one detection member may be operably supported within the elongated shaft. Each detection member may have a distal portion that is radially deployable away from the central axis upon application of a deployment motion thereto. The distal end portions may have a bumper or light mounted thereto.

WO 2012/015907 A1

Published:

— with international search report (Art. 21(3))

— before the expiration of the time limit for amending the claims and to be republished in the event of receipt of amendments (Rule 48.2(h))

TRANSWALL VISUALIZATION ARRANGEMENTS FOR SURGICAL CIRCULAR STAPLERS

FIELD OF THE INVENTION

[0001] The present invention generally relates to surgical staplers, and more particularly, to devices and methods for holding and/or protecting tissue adjacent to the stapler head of a circular stapler.

BACKGROUND

[0002] In certain types of surgical procedures, the use of surgical staples has become the preferred method of joining tissue and, as such, specially configured surgical staplers have been developed for these applications. For example, intra-luminal or circular staplers have been developed for use in surgical procedures involving the lower colon wherein sections of the lower colon are joined together after a diseased portion has been excised. Circular staplers useful for performing such procedures are disclosed, for example, in U.S. Pat. Nos. 5,104,025; 5,205,459; 5,285,945; and 5,309,927 which are each herein incorporated by reference in their respective entireties.

[0003] In general, a conventional circular stapler typically consists of an elongated shaft that has a proximal actuating mechanism and a distal stapler head mounted to the elongated shaft. The distal stapler head commonly consists of a fixed stapling cartridge that contains a plurality of staples configured in a concentric circular array. A round cutting knife is concentrically mounted in the cartridge interior to the staples for axial travel therein. Extending axially from the center of the cartridge is a movable trocar shaft that is adapted to have a staple anvil removably coupled thereto. The anvil is configured to form the ends of the staples as they are driven into it. The distance between a distal face of the staple cartridge and the staple anvil is commonly controlled by an adjustment mechanism that is mounted to the proximal end of the stapler shaft for controlling the axial movement of the trocar. Tissue that is clamped between the staple cartridge and the staple anvil is simultaneously stapled and cut when the actuating mechanism is activated by the surgeon.

[0004] When performing a lower colon procedure using a circular stapler, a portion of the intestine may be laproscopically stapled using a conventional surgical stapler that is inserted through a trocar. The conventional surgical stapler serves to place multiple rows of staples on either side of the diseased portion of colon to be removed. The target or diseased section is simultaneously cut as the adjoining end of the colon is stapled. After removing the diseased portion, the surgeon typically inserts the anvil of the circular stapling instrument into the distal end of the lumen, distal of the staple line. This may be done by inserting the anvil head into an entry port cut into the distal lumen by the surgeon. The lower staple line is utilized to hold the tissue of the colon over the circular cartridge. This method seals both ends of the colon only to have the sealed portions cut through and removed. These intermediate step staple lines are only temporary and facilitate the next step in the procedure.

[0005] On occasion, the anvil can be placed transanally, by placing the anvil head on the distal end of the stapler and inserting the instrument through the rectum. Once the anvil has been installed in the distal portion of the intestine, the intestine is secured around the anvil shaft by what is known as a “purse string” suture. The proximal portion of intestine is similarly secured around the stapler head by a purse string suture.

[0006] Once the ends of the intestine have been secured around their respective components, the surgeon, through an appropriate trocar sleeve, may employ a grasping device to grasp the anvil shaft and attach it to the portion of the trocar protruding within the stapler head. The surgeon then closes the gap between the anvil and cartridge, thereby clamping the proximal and distal ends of the intestine in the gap. The surgeon next actuates the stapler causing several rows of staples to be driven through both ends of the intestine and formed, thereby joining the ends and forming a tubular pathway. Simultaneously, as the staples are driven and formed, the concentric annular knife blade is driven through the intestinal tissue ends, cutting the ends adjacent to the inner row of staples. The surgeon then withdraws the stapler from the intestine and the procedure is complete.

[0007] Such procedures and devices require the surgeon to install two purse string sutures which lengthens the time required to complete the surgical procedure. In addition, such procedures may at times cause tissue “bunching” during the tissue cutting/stapling process.

[0008] Various attempts have been made to retain colon and other tissues around the stapling device. For example, U.S. Patent Nos. 5,309,927; 6,117,148; and 7,094,247 disclose

various arrangements that, in general, employ fasteners, ligation members, rings, springs, etc. that are apart from the stapling device itself in an effort to retain the tissue in position. U.S. Patent No. 5,669,918 discloses a mechanism that employs a grasper like arm to frictionally pin the tissue against the trocar shank. While such device is essentially self contained, the grasper arms may ultimately be unable to effectively retain the tissue in position in practice.

[0009] Thus, the need exists for devices and methods for reducing the time required to complete the surgical procedure as well as addressing other shortcomings and challenges associated with retaining tissue in position when employing circular stapler arrangements.

[0010] The foregoing discussion is intended only to illustrate some of the shortcomings present in the field of the invention at the time, and should not be taken as a disavowal of claim scope.

BRIEF SUMMARY

[0011] In accordance with one general aspect of various non-limiting embodiments of the present invention, there is provided a surgical instrument that comprises an elongated shaft that defines a central axis and have a distal end portion that is configured to operably support a circular staple cartridge therein. At least one detection member is operably supported within the elongated shaft. Each detection member has a distal portion that is radially deployable away from the central axis upon application of a deployment motion thereto. A light may be provided on the distal portion of the detection member.

[0012] In accordance with another general aspect of various non-limiting embodiments of the present invention, there is provided a surgical instrument that comprises a handle assembly that has an elongated shaft protruding therefrom. The elongated shaft defines a central axis and has a distal end portion that is configured to operably support a circular staple cartridge therein. At least one detection member is operably supported within the elongated shaft. Each detection member has a distal portion that is radially deployable away from the central axis upon application of a deployment motion thereto. At least one acquisition member is operably supported within the elongated shaft. Each acquisition member has a tissue-piercing distal portion that is radially deployable away from the central axis upon application of a deployment motion to the acquisition member.

[0013] In accordance with yet another general aspect of various non-limiting embodiments of the present invention, there is provided a surgical instrument that comprises a handle assembly that has an elongated shaft protruding therefrom. The elongated shaft defines a central axis and has a distal end portion that is configured to operably support a circular staple cartridge therein. At least one detection member is operably supported within the elongated shaft. Each detection member has a distal portion that is radially deployable away from the central axis upon application of a deployment motion thereto. At least one flexible knife member is movably supported in the elongated shaft. Each knife member has a distal cutting portion that is axially advanceable out of the distal end portion of the elongated shaft upon application of an axial actuation motion thereto. Each knife member is selectively rotatable about the central axis upon application of a rotary actuation motion thereto.

[0014] In accordance with still another general aspect of various non-limiting embodiments of the present invention, there is provided a surgical procedure for treating a tubular organ. In various non-limiting embodiments, the procedure comprises inserting a circular stapler head of a surgical instrument into the tubular organ. The procedure further comprises deploying at least one lighted detection member operably supported by the surgical instrument from a retracted position to a deployed position adjacent a wall of the tubular organ. The procedure further comprises observing light from the lighted detection member through the organ wall to assess the location of the circular stapler head within the tubular organ.

BRIEF DESCRIPTION OF THE FIGURES

[0015] The accompanying drawings, which are incorporated in and constitute a part of this specification, illustrate embodiments of the invention, and, together with the general description of the invention given above, and the detailed description of the embodiments given below, serve to explain the principles of the present invention.

[0016] FIG. 1 is a perspective view of a surgical circular stapling instrument of various non-limiting embodiments of the present invention;

[0017] FIG. 1A is a cross-sectional view of the handle portion of various embodiments of the surgical stapling instrument of the present invention;

[0018] FIG. 2 is a cross-sectional view of a distal end portion of the elongated shaft of the circular stapling instrument of FIG. 1;

[0019] FIG. 2A is a partial cross-sectional view of the distal end of the elongated shaft with an anvil coupled thereto;

[0020] FIG. 2B is a partial cross-sectional view of the distal end of the elongated shaft taken along line 2B-2B in FIG. 2A;

[0021] FIG. 2C is a cross-sectional view of a portion of the handle assembly of an embodiment of the present invention;

[0022] FIG. 2D is a cross-sectional view of another portion of the elongated shaft of various embodiments of the present invention;

[0023] FIG. 3 is an end view of the elongated shaft of FIG. 2;

[0024] FIG. 4 is a partial perspective view of the distal end portion of the elongated shaft of FIGS. 2 and 3 with the tissue acquisition members and the knife members thereof in their radially deployed positions;

[0025] FIG. 5 is a partial cross-sectional view of the distal end of the elongated shaft with an anvil coupled thereto and inserted into a portion of a patient's tubular organ such as a colon;

[0026] FIG. 6 is another cross-sectional view of the distal end of the elongated shaft of FIG. 5 with the anvil removed therefrom;

[0027] FIG. 7 is another cross-sectional view of the distal end of the elongated shaft of FIGS. 5 and 6 with the distal end portion of the cutter housing being axially advanced beyond the distal face of the staple cartridge supported in the distal end of the elongated shaft;

[0028] FIG. 8 is another cross-sectional view of the distal end of the elongated shaft of FIG. 7 with tissue acquisition members being radially deployed out of the tissue acquisition housing and piercing through a portion of the colon;

[0029] FIG. 9 is another cross-sectional view of the distal end of the elongated shaft of FIG. 8 with the tissue acquisition members thereof being withdrawn back into the tissue

acquisition housing to position the punctured portion of the colon adjacent to the distal face of the staple cartridge;

[0030] FIG. 10 is another cross-sectional view of the distal end of the elongated shaft of FIG. 9 with the knife members radially deployed out of the cutter housing and puncturing through another portion of the colon;

[0031] FIG. 11 is another cross-sectional view of the distal end of the elongated shaft of FIG. 10 after the knife members have been rotated to sever the retained punctured portion of colon from a diseased portion of the colon;

[0032] FIG. 12 is another cross-sectional view of the distal end of the elongated shaft of FIG. 11 with the knife members withdrawn back into their respective lumens in the cutter housing;

[0033] FIG. 13 is another cross-sectional view of the distal end of the elongated shaft of FIG. 12 after an anvil has been secured to a distal portion of the colon and the anvil stem thereof has been coupled to the anvil assembly portion of the circular stapling instrument;

[0034] FIG. 14 is another cross-sectional view of the distal end of the elongated shaft of FIG. 13 after the anvil has been drawn adjacent to the distal face of the staple cartridge;

[0035] FIG. 15 is another cross-sectional view of the distal end of the elongated shaft of FIG. 14 after the staples have been deployed and annular knife has been axially advanced through the adjacent portions of colon;

[0036] FIG. 16 is another cross-sectional view of the distal end of the elongated shaft of FIG. 15 after the colon sections have been stapled together, but prior to being withdrawn from the colon;

[0037] FIG. 17 is a perspective view of a surgical circular stapling instrument of various non-limiting embodiments of the present invention;

[0038] FIG. 18 is a cross-sectional view of a distal end portion of the elongated shaft of the circular stapling instrument of FIG. 17;

[0039] FIG. 19 is an exploded assembly view of the acquisition and deployment shafts of various non-limiting embodiments of the present invention;

[0040] FIG. 20 is a partial perspective view of the acquisition shaft of FIG. 19 with the tissue arms thereof in a retracted position;

[0041] FIG. 21 is a partial cross-sectional view of the acquisition shaft of FIGS. 19 and 20, with the tissue arms thereof in a deployed position;

[0042] FIG. 22 is a perspective view of the acquisition shaft of FIG. 21;

[0043] FIG. 23 is a cross-sectional view of the elongated shaft of various non-limiting embodiments of the present invention, with an anvil attached thereto and inserted into a portion of a patient's colon;

[0044] FIG. 24 is another cross-sectional view of the elongated shaft of FIG. 23, with the anvil removed and the acquisition arms deployed through a proximal portion of the colon that is adjacent to a target or diseased portion of the colon;

[0045] FIG. 25 is a top cross-sectional view of the elongated shaft of FIG. 24 taken along line 25-25 in FIG. 24 with the tissue acquisition arms extended through the proximal portion of the colon;

[0046] FIG. 26 is a partial cross-sectional view of the elongated shaft of FIGS. 24 and 25 with the targeted or diseased portion of the colon being removed with a grasping instrument;

[0047] FIG. 27 is a top cross-sectional view of the elongated shaft of FIG. 26 taken along line 27-27 in FIG. 26;

[0048] FIG. 28 is a partial cross-sectional view of the elongated shaft after the anvil has been inserted into a distal portion of the colon and secured thereto by a purse-string suture arrangement;

[0049] FIG. 29 is a cross-sectional view of the elongated shaft of FIG. 28 after the anvil has been coupled to the anvil assembly thereof and drawn into confronting relationship with the stapling cartridge therein;

[0050] FIG. 30 is a cross-sectional view of the elongated shaft of FIG. 29 after the staple cartridge had been fired and the annular cutting member advanced through the stapled tissue portions;

[0051] FIG. 31 is a cross-sectional view of the elongated shaft of FIG. 30 being withdrawn from the colon after completion of the stapling procedure;

[0052] FIG. 32 is a perspective view of another a surgical circular stapling instrument of various non-limiting embodiments of the present invention;

[0053] FIG. 33 is a cross-sectional view of a distal end portion of the elongated shaft of the circular stapling instrument of FIG. 32;

[0054] FIG. 34 is a partial perspective view of a hook and detection housing portion of the elongated shaft of FIG. 33 with the detection members thereof in a retracted position;

[0055] FIG. 35 is another partial perspective view of the hook and detection housing of FIG. 34 with the detection members thereof in a deployed orientation;

[0056] FIG. 36 is a partial cross-sectional view of the distal end of the elongated shaft with the detection members thereof in a deployed orientation within a colon;

[0057] FIG. 37 is a top cross-sectional view of the elongated shaft and colon of FIG. 36 taken along line 37-37 in FIG. 36;

[0058] FIG. 38 is a perspective view of another circular stapling instrument of various non-limiting embodiments of the present invention;

[0059] FIG. 39 is a cross-sectional view of a distal end portion of the elongated shaft of the circular stapling instrument of FIG. 38 inserted into the proximal portion of a tubular organ such as a colon;

[0060] FIG. 40 is an exploded assembly view of distal end portions of a tissue acquisition shaft, a deployment shaft and a knife shaft of various non-limiting embodiments of the present invention;

[0061] FIG. 41 is a partial perspective view of the tissue acquisition shaft of FIG. 40 with the tissue arms thereof in a retracted position;

[0062] FIG. 42 is a perspective view of the acquisition shaft of FIG. 41 with the tissue arms thereof in deployed positions;

[0063] FIG. 43 is a partial cross-sectional view of a distal end portion of the elongated shaft of the surgical instrument of FIG. 38 inserted into a proximal portion of the colon with the anvil assembly removed therefrom;

[0064] FIG. 44 is a partial cross-sectional view of the distal end portion of the elongated shaft with the tissue acquisition arms deployed through a proximal portion of the colon;

[0065] FIG. 45 is a top cross-sectional view of the distal end portion of the elongated shaft take along line 45-45 in FIG. 44;

[0066] FIG. 46 is another partial cross-sectional view of the distal end portion of the elongated shaft after the tissue acquisition arms have been deployed through the proximal portion of the colon and then moved to a retracted position wherein the pierced proximal portion is trapped between the tissue acquisition arms and the tissue acquisition shaft;

[0067] FIG. 47 is a top cross-sectional view of the distal end portion of the elongated shaft of FIG. 46 taken along line 47-47 in FIG. 46;

[0068] FIG. 48 is a partial cross-sectional view of the distal end portion of the elongated shaft with the diseased portion of the colon being severed from the proximal portion and distal portion and being removed from the colon by conventional graspers;

[0069] FIG. 49 is a partial cross-sectional view of the elongated shaft after the anvil has been inserted into a distal portion of the colon and secured thereto by a purse-string suture arrangement;

[0070] FIG. 50 is a cross-sectional view of the elongated shaft of FIG. 49 after the anvil has been coupled to the anvil assembly thereof and drawn into confronting relationship with the staple cartridge therein;

[0071] FIG. 51 is a cross-sectional view of the elongated shaft of FIG. 50 after the staple cartridge had been fired and the annular cutting member advanced through the stapled tissue portions;

[0072] FIG. 52 is a cross-sectional view of the elongated shaft of FIG. 51 being withdrawn from the colon after completion of the stapling procedure;

[0073] FIG. 53 is a view of a portion of a patient's opened abdominal cavity illustrating various tissues and structures adjacent a portion of the colon;

[0074] FIG. 54 is another partial view of the open abdominal cavity of FIG. 53;

[0075] FIG. 55 is another view of the abdominal cavity of FIG. 53 illustrating the insertion of a trocar into the abdominal cavity to deliver a protective sheath embodiment of the present invention therein;

[0076] FIG. 56 is another view of the abdominal cavity of FIG. 55 with the protective sheath embodiment being withdrawn from the trocar sleeve by a conventional grasping device;

[0077] FIG. 57 is another view of the abdominal cavity of FIG. 56 illustrating one method of positioning the protective sheath around the circumference of a portion of the colon to be treated; and

[0078] FIG. 58 is another view of the abdominal cavity of FIG. 57 after the protective sheath embodiment has been positioned around the outer circumference of the portion of colon to be treated.

DETAILED DESCRIPTION

[0079] The Applicant of the present application also owns the U.S. Patent Applications identified below which were filed on even date herewith and which are each herein incorporated by reference in their respective entirety:

U.S. Patent Application Serial No. _____, entitled "Surgical Circular Stapler With Tissue Retention Arrangements", Attorney Docket No. END6741USNP/100065;

U. S. Patent Application Serial No. _____, entitled "Tissue Acquisition Arrangements and Methods For Surgical Stapling Devices", Attorney Docket No. END6739USNP/100063;

U.S. Patent Application Serial No. _____, entitled "Circular Stapling Instruments With Secondary Cutting Arrangements and Methods of Using Same", Attorney Docket No. END6740USNP/100064; and

U.S. Patent Application Serial No. _____, entitled "Apparatus and Methods For Protecting Adjacent Structures During the Insertion of a Surgical Instrument Into a Tubular Organ", Attorney Docket No. END6737USNP/100061.

[0080] Certain exemplary embodiments will now be described to provide an overall understanding of the principles of the structure, function, manufacture, and use of the devices

and methods disclosed herein. One or more examples of these embodiments are illustrated in the accompanying drawings. Those of ordinary skill in the art will understand that the devices and methods specifically described herein and illustrated in the accompanying drawings are non-limiting exemplary embodiments and that the scope of the various embodiments of the present invention is defined solely by the claims.

[0081] Reference throughout the specification to “various embodiments,” “some embodiments,” “one embodiment,” or “an embodiment”, or the like, means that a particular feature, structure, or characteristic described in connection with the embodiment is included in at least one embodiment. Thus, appearances of the phrases “in various embodiments,” “in some embodiments,” “in one embodiment”, or “in an embodiment”, or the like, in places throughout the specification are not necessarily all referring to the same embodiment.

Furthermore, the particular features, structures, or characteristics may be combined in any suitable manner in one or more embodiments. Thus, the particular features, structures, or characteristics illustrated or described in connection with one embodiment may be combined, in whole or in part, with the features structures, or characteristics of one or more other embodiments without limitation. Such modifications and variations are intended to be included within the scope of the present invention.

[0082] The terms “proximal” and “distal” are used herein with reference to a clinician manipulating the handle portion of the surgical instrument. The term “proximal” referring to the portion closest to the clinician and the term “distal” referring to the portion located away from the clinician. It will be further appreciated that, for convenience and clarity, spatial terms such as “vertical”, “horizontal”, “up”, and “down” may be used herein with respect to the drawings. However, surgical instruments are used in many orientations and positions, and these terms are not intended to be limiting and/or absolute.

[0083] FIG. 1 illustrates a circular stapler 10 according to various non-limiting embodiments of the invention. In various embodiments, the circular stapler 10 includes a handle assembly 12 that has an elongated shaft assembly 14 protruding therefrom that defines a central axis A-A. The elongate shaft assembly 14 includes a rigid outer sheath 16 that has a distal end portion 17 that forms a stapler head 20. In various non-limiting embodiments, the stapler head 20 is configured to operably support a circular staple cartridge 30 therein. Such circular staple cartridges 30 are known in the art and may generally support one, two, or more circumferentially spaced and staggered rows of staples 36 therein. See FIGS. 2 and 3. The

embodiment depicted in FIG. 3, for example, has two rows 32, 34, of staples 36. A conventional annular knife 40 is coaxially and movably supported within the stapler head 20.

[0084] In certain implementations, the circular stapler 10 further includes a firing shaft assembly 50 that is supported within the outer sheath 16 for selective axial travel therein. See FIG. 2. A distal end portion 52 of the firing shaft assembly 50 has an outer staple driver portion 54 thereon for engagement with each of the staples 36 in the outer row 32 of staples 36 in the staple cartridge 30. In addition, the distal end portion 52 of the firing shaft assembly 50 has an inner staple driver portion 56 that is configured for engagement with each of the staples 36 in the inner row 34 of staples 36 within the staple cartridge 30. As can also be seen in FIG. 2, for example, the distal end portion 52 of the firing shaft assembly 50 further has a ledge 58 that is configured to engage the annular knife 40. Thus, as will be discussed in further detail below, axial advancement of the firing shaft assembly 50 in a distal direction “DD”, will cause the staples 36 to be driven out of the staple cartridge 30 as well as the annular knife 40 to be advanced distally. As can be seen in FIG. 2A, the firing shaft assembly 50 has a base portion 51 that is coupled to a firing rod 53.

[0085] In various non-limiting embodiments, the firing rod 53 operably interfaces with a firing trigger 60 that is operably coupled to the handle assembly 12. See FIGS. 1 and 1A. As can be seen in FIGS. 1 and 1A, the firing trigger 60 is pivotally coupled to the handle assembly 12 such that when the firing trigger 60 is pivoted toward the handle assembly 12, the firing shaft assembly 50 is moved in the distal direction DD. Such firing trigger arrangements are known in the art and therefore will not be discussed in detail herein. For example, an exemplary firing trigger arrangement is disclosed in U.S. Patent Application Publication No. US 2008/0078806 A1, entitled “Surgical Stapling Instrument With Mechanical Indicator to Show Levels of Tissue Compression”, the disclosure of which is herein incorporated by reference in its entirety.

[0086] As shown in FIGS. 2 and 2A, various non-limiting embodiments include an acquisition housing 70 that is coaxially supported within the firing shaft assembly 50 and is axially movable relative thereto. The acquisition housing 70 has a plurality of acquisition lumens 72 therein that each movably support an acquisition or hook member 80. As can be seen in FIG. 3, for example, the plurality of three-sided acquisition lumens 72 may be equally spaced around the circumference of the acquisition housing 70. In the non-limiting

embodiment depicted in FIG. 3, a total of eight (8) acquisition lumens 72 are equally spaced around the circumference of the acquisition housing 70.

[0087] Each acquisition or hook member 80 may be fabricated from, for example, Nitinol, 300 or 400 series stainless steel (fully or three-fourths hardened) and have a distal end portion 82 that, when advanced out of its respective acquisition lumen 72, bends radially outward as shown in FIG. 4. As can also be seen in FIG. 4, each hook member 80 has a tissue barb 84 formed on the distal end portion 82 thereof. As can be seen in FIGS. 2 and 3, in various non-limiting embodiments, a sleeve 78 is employed to facilitate installation of the hook members 80 into their respective lumens 72.

[0088] As can be seen in FIG. 2A, each of the hook members 80 are coupled to or protrude from an acquisition ring 81 that has a pair of acquisition rods 83 attached thereto. The acquisition rods 83 are attached to a hook switch 90 that is operably supported on the handle assembly 12. See FIGS. 1 and 2C. As the surgeon moves the hook switch 90 in a distal direction (arrow 92 in FIGS. 1 and 2C), the acquisition housing 70 moves distally. Such movement of the acquisition housing 70 causes the distal end portion 84 of each hook member 80 to be advanced distally out of its respective acquisition lumen 72. As the distal end portion 84 of each hook member 80 is advanced out of the acquisition lumen 72, the natural bending action of the hook member 80 causes the end portion 84 to bend radially away from the central axis A-A as illustrated in FIG. 4. The surgeon may retract the acquisition housing 70 and the hook members 80 into their starting positions (FIG. 2), by moving the hook switch 90 in a proximal direction (arrow 94 in FIGS. 1 and 2C).

[0089] As can be further seen in FIGS. 2, 2A, 2D, 3 and 4, in various non-limiting embodiments, a cutter housing 100 is coaxially supported within the acquisition housing 70. The cutter housing 100 is supported for selective axial travel relative to the acquisition housing 70 and for selective axial travel along central axis A-A. In various embodiments, a pair of housing actuation rods 101 protrude from the cutter housing 100 to interface with a knife knob 110 that is movably supported on the handle assembly 12. See FIGS. 1 and 2D. In various non-limiting embodiments, the knife knob 110 is supported on the handle assembly 12 such that it can move axially (represented by arrows 112, 114 in FIGS. 1 and 2D) and also be rotated relative to the handle assembly 12 (represented by arrow 116 in FIG. 1). The housing actuator rods 101 are attached to the knife knob 110 such that movement of

the knife knob 110 in an axial direction moves the cutter housing 100 axially within the acquisition housing 70 and rotation of the knife knob 110 also rotates the cutter housing 100 about the central axis A-A as will be discussed in further detail below.

[0090] In various non-limiting embodiments, the cutter housing 100 includes at least one, and preferably a plurality of, knife lumens 102 that extend axially through the wall of the cutter housing 100. As can be seen in FIG. 3, for example, the plurality of knife lumens 102 may be spaced equally around the circumference of the cutter housing 100. In the non-limiting embodiment depicted in FIG. 3, a total of eight (8) knife lumens 102 are equally spaced around the circumference of the cutter housing 100. As can be seen in FIGS. 2 and 4, each knife lumen 102 has a curved distal end portion 104 that opens radially outward.

[0091] In various non-limiting embodiments, a flexible knife member 120 is slidably received within each knife lumen 102. Each flexible knife member 120 has a sharpened distal end 122 and is attached to or protrudes from a knife ring 123. A pair of knife actuator rods 125 are attached to the knife ring 123 by a slip joint arrangement 127 that permits the knife ring 123 to rotate relative to the actuator rods 125. See FIG. 2A. As can be seen in FIG. 2C, the knife actuator rods 125 (only one knife actuator rod 125 is shown in that view) are attached to a knife switch 130 that is operably mounted to the handle 12. The distal end 122 of each knife member 120 is substantially pointed to enable it to pierce through tissue and it may have at least one cutting edge 124 formed thereon. When the knife switch 130 is moved in the distal direction (arrow 132), the knife members 120 are moved distally within the knife lumens 102 such that the sharpened distal end 122 “naturally” flexes or bends radially out of the curved distal end portion 104 of the lumen 102 as shown in FIG. 4. As used in this context, the term “naturally” means that the material may be prestressed or otherwise formed such that the distal end thereof flexes or bends as it exits the lumen. Likewise, movement of the knife switch 130 in the proximal direction (represented by arrow 134 in FIGS. 1 and 2C) causes each knife member 120 to be retracted back into its knife lumen 102. In various non-limiting embodiments, the knife members 120 may be fabricated from, for example, Nitinol, 300 or 400 series stainless steel (fully or three-fourths hardened).

[0092] As can also be seen in FIG. 2A, the firing shaft assembly 50 has a distal end post 140 that protrudes from the base portion 51 and coaxially extends within the cutter housing 100 for selective axial travel therein. Various embodiments also include a bulkhead member

141 that is mounted within the outer sheath 116. To facilitate easy assembly, the outer sheath 16 may comprise a distal outer sheath segment 16 and a proximal outer sheath segment 16' as shown in FIG. 2A. In addition, a distal end post 142 extends from the bulkhead 51 and supports a distal anvil connector 150. The distal anvil connector 150 is coupled to a distal band assembly 151. The distal band assembly 151 is coupled to a control rod assembly 153 that interfaces with an adjustment knob 160 that is rotatably supported on the handle assembly 12. Such anvil shaft assemblies and control knob arrangements are generally known. For example, the control rod assembly and control knob may be configured as disclosed in published U.S. Patent Application No. US 2008/0078806 A1, entitled "Surgical Stapling Instrument With Mechanical Indicator To Show Levels of Tissue Compression, which has been herein incorporated by reference.

[0093] As can be seen in FIG. 2B, each of the housing actuator rods 101 protrude through a corresponding arcuate slot 145 in the bulkhead 141. The slots 145 may be sized to define/limit the amount that the cutter housing 100 may be rotated relative to the central axis A-A. For example, in one embodiment wherein a total of eight (8) knife members 120 are employed, the slots 145 may be sized to facilitate at least approximately 45°- 50° of arcuate or rotational travel of the cutter housing 100 about the central axis A-A. The bulkhead 141 may further have an aperture 146 for permitting the distal band assembly 151 to protrude therethrough. In addition, each of the knife actuator rods 125 extends through a corresponding opening 147 in the bulkhead 141. Similarly, each of the acquisition rods 83 extend through a corresponding aperture 148 in the bulkhead 141. See FIG. 2B.

[0094] The circular stapler 10 further includes an anvil 170 as shown in FIG. 5. In various non-limiting embodiments, the anvil 170 includes an anvil base 171 that has a series of staple forming pockets 172 therein and an anvil shaft 174 that is removably attachable to the distal anvil connector 150. In particular, a coupling stem 176 protrudes from the proximal end 175 of the anvil shaft 174 and is sized to be slidably received in a passage 152 in the distal anvil connector 150. The anvil 170 further has an anvil cap 178 thereon as illustrated in FIGS. 5 and 13 that defines a tissue cavity 179 therein.

[0095] One exemplary method of using the circular stapler 10 will be described with reference to FIGS. 5-16. The various embodiments of the circular stapler 10 are particularly well-suited for performing a circular anastomosis of a tubular organ such as, for example, the

colon. Turning first to FIG. 5, the stapler head 20 is inserted into a proximal portion 201 of the colon 200 through the patient's anus 199. In applications wherein a diseased or targeted portion 202 of colon is to be removed, the stapler head 20 is positioned adjacent to the diseased portion 202. See FIG. 6.

[0096] Once the stapler head 20 has been inserted to the appropriate position relative to the diseased portion 202, the cutter housing 100 is advanced distally by axially advancing the knife knob 110 in a distal direction (represented by arrows 112 in FIGS. 1 and 7). At this stage in the procedure, the knife members 120 have not been advanced out of their respective knife lumens 102. Thereafter, the surgeon advances the acquisition housing 70 distally by moving the hook switch 90 in the distal direction (arrow 92 in FIG. 1). Movement of the acquisition housing 70 in the distal direction causes the hook members 80 to move axially out of their respective acquisition lumens 72. As the distal ends of the hook members 80 exit their respective acquisition lumens 72, they naturally flex radially outward to engage and pierce through the proximal portion 201 of the colon 200. See FIG. 8. Once the hook members 80 have pierced and engaged the proximal portion 201 of the colon 200, the surgeon moves the hook switch 90 in the proximal direction (represented by arrow 94 in FIG. 1) to retract the hook members 80 into their respective acquisition lumens 72 as well as to retract the acquisition housing 100 back to its starting position. The barbs 84 on the distal ends of the hook members 80 draw the engaged proximal portion 201 into the position illustrated in FIG. 9. Thus, the engaged proximal portion 201 of the colon 200 is drawn over a distal face 31 of the staple cartridge 30 and partially into the interior space 33 between the staple cartridge 30 and the cutter housing 100.

[0097] Once the engaged proximal portion 201 of the colon 200 has been drawn into the position illustrated in FIG. 9, the surgeon then extends the knife members 120 out of their respective knife lumens 102 by axially advancing the knife knob 110 on the handle assembly 12 in the distal direction (represented by arrow 112 in FIG. 1). By moving the knife knob 110 distally, the knife members 120 are advanced out of their knife lumens 102 and the curved portion 104 of each knife lumen 102 causes the knife member 120 therein to move radially outward as illustrated in FIG. 10. The knife members 120 protrude through the proximal portion 201 of the colon 200 that is proximal to the diseased colon portion 202. See FIG. 10. Thereafter, the diseased colon portion 202 may be severed from the proximal colon portion 201 by rotating the knife knob 110 on the handle assembly 12 (represented by arrow

116 in FIG. 1). Rotation/actuation of the knife knob 110 will cause the cutter housing 100 and the knife members 120 to rotate about the central axis A-A and cut through the colon tissue. After the diseased portion 202 has been cut away from the proximal colon portion 201 (FIG. 11), the surgeon may retract the knife members 120 back into their respective knife lumens 102 by moving the knife knob 110 in a proximal direction (represented by arrow 114 in FIG. 1). See FIG. 12.

[0098] The diseased portion 202 may be severed from the distal colon portion 208 (FIG. 13), by means of, for example, a conventional laparoscopic tissue severing device (not shown) that has been inserted through a trocar sleeve that extends into the abdominal cavity 601 that is adjacent to the diseased portion 202. The diseased colon portion 202 may then be removed through the trocar sleeve. The surgeon then orients the anvil 170 within the distal colon portion 206 such that the anvil shaft 174 protrudes out of the distal colon portion 206 as shown in FIG. 13. The surgeon then ties the end of the distal colon portion 206 around the anvil shaft 174 using what is known in the art as a “purse string suture” 220. Once the distal colon portion 206 has been sutured around the anvil shaft 174, the coupling stem 176 of the anvil shaft 174 is inserted into the passage 152 in the anvil shaft assembly 150. The coupling stem 176 may be sized relative to the passage 152 to establish a frictional fit therebetween to retain the coupling stem 176 therein, yet permit the coupling stem 176 to be removed therefrom at a later time.

[0099] The surgeon then draws the anvil 170 toward the stapler head 20 (in the proximal direction “PD”) by rotating the anvil control knob 160 in the appropriate direction until colon portions 205, 210 are clamped between the anvil 170 and the staple cartridge 30 as shown in FIG. 14. Thereafter, the surgeon actuates the firing trigger 60 to axially advance the firing shaft assembly 50 in the distal direction “DD”. As firing shaft assembly 50 is advanced distally, the outer staple driver portion 54 and the inner staple driver portion 56 serve to drive the staples 36 located in the outer row 32 and inner row 34, respectively, through the colon portions 205, 210 into the anvil forming pockets 172 in the anvil base 171. The firing shaft assembly 50 also advances the annular knife 40 through the colon portion 205 to cut the portion 201 therefrom. See FIG. 15. Further advancement of the annular knife 40 severs colon portion 207 from colon portion 208. The surgeon then moves the anvil 170 in the distal direction “DD” to release the stapled colon portions 205, 210 from between the anvil base 171 and the face 31 of the staple cartridge 30. See FIG. 16. The instrument 10 may then be

removed from the colon 200. The cut portion 201 remains in the stapler head 20 and the cut portion 207 remains in the tissue cavity 179 in the anvil 170 as the surgeon withdraws the instrument 10 out through the patient's anus 199. Thus, the cut portions 201, 207 of the colon 200 are removed from the repaired colon when the instrument is withdrawn therefrom.

[0100] FIG. 17 illustrates another circular stapler 300 according to various non-limiting embodiments of the invention. The circular stapler 300 generally includes a handle assembly 312 that has an elongated shaft 314 protruding therefrom. The elongated shaft 314 may define a central axis A-A. As can be seen in FIG. 17, the elongate shaft 314 includes a rigid outer sheath 316 that supports a stapler head 320 thereon. In various non-limiting embodiments, the stapler head 320 is configured to support a circular staple cartridge 330 therein. Such circular staple cartridges 330 are known in the art and generally support one or two or more circumferentially spaced and staggered rows of staples 36 therein as was described hereinabove. A conventional annular knife 340 is coaxially and movably supported within the staple cartridge 330. See FIG. 18.

[0101] In certain implementations, the circular stapler 300 further includes a firing shaft 350 that is operably supported within the rigid outer sheath 316 for selective axial travel therein as was discussed above. See FIG. 18. A distal end portion 352 of the firing shaft 350 has an outer staple driver portion 354 thereon for engagement with each of the staples 36 in the outer row 32 of staples 36 in the staple cartridge 330. In addition, the distal end portion 352 of the firing shaft 350 has an inner staple driver portion 356 configured for engagement with each of the staples 36 in the inner row 34 of staples 36 within the staple cartridge 330. As can also be seen in FIG. 18, for example, the distal end portion 352 of the firing shaft 350 further has a flanged portion 358 that is configured to engage the annular knife 340. Thus, as will be discussed in further detail below, axial advancement of the firing shaft 350 in a distal direction "DD", will cause the staples 36 to be driven out of the staple cartridge 330 as well as the annular knife 340 to advanced distally.

[0102] In various non-limiting embodiments, the firing shaft 350 interfaces with a firing trigger 360 that is operably coupled to the handle assembly 312. As can be seen in FIG. 17, the firing trigger 360 is pivotally coupled to the handle assembly 312 such that when the firing trigger 360 is pivoted toward the handle assembly 312, the firing shaft 350 is moved in

the distal direction DD. As was discussed above, such firing trigger arrangements are known in the art and therefore will not be discussed in detail herein.

[0103] As shown in FIG. 18, various non-limiting embodiments also include a deployment shaft 370 that is coaxially and rotatably supported within a tissue acquisition shaft 380 that is non-rotatably supported within the elongated shaft 316. The proximal end of the deployment shaft 370 operably interfaces with a tissue acquisition knob 310 that is rotatably supported on the handle assembly 312. The deployment shaft 370 interfaces with the tissue acquisition knob 310 in the manner described above with respect to knife knob 110. Thus, rotation/actuation of the tissue acquisition knob 310 on the handle assembly 312 will result in the rotation of the deployment shaft 370 within the tissue acquisition shaft 380 about the central axis A-A. More specifically and with reference to FIG. 19, in various embodiments, a distal end 372 of the deployment shaft 370 protrudes through a hole 382 in the acquisition shaft 380 and has a drive gear 374 attached thereto. A distal end 384 of the acquisition shaft 380 is configured to operably support at least two tissue acquisition members or tissue arms 400 thereon. In the non-limiting embodiment depicted in FIG. 19, a total of four tissue arms 400 are pivotally pinned to the distal end 384 of the tissue acquisition shaft 380 by corresponding pins 386 such that each tissue arm 400 pivots about a corresponding “acquisition” axis B-B that is substantially parallel to the central axis A-A. See FIGS. 21 and 23.

[0104] As can be seen in FIGS. 19 and 22, each tissue arm 400 has a body portion 402 that may be fabricated from, for example, stainless steel (300 or 400 series), or titanium-steel composite or ceramic, etc. and have a driven gear 404 attached thereto or formed thereon. The driven gear 404 of each tissue arm 400 is movably supported within a corresponding arm cavity 388 formed in the distal end 384 of the tissue acquisition shaft 380. Each driven gear 404 is in meshing engagement with the drive gear 374 on the deployment shaft 370. Thus, rotation of the deployment shaft 370 will result in the pivotal deployment of the tissue arms 400 from the retracted position depicted in FIG. 20 to the deployed position depicted in FIG. 22. As can be seen in FIGS. 20 and 22, in various embodiments, each tissue arm 400 has an arcuate shape such that when the tissue arms 400 are in a retracted position as shown in FIG. 20, they cooperate to create a round disc-like assembly 401 at the distal end of the tissue acquisition shaft 380.

[0105] In various embodiments, the body portion 402 of each tissue arm 400 further has a tissue piercing tip 406 formed thereon or otherwise attached thereto. In addition, an arm knife 408 that has a cutting edge 410 formed thereon is attached to or is otherwise formed on the body portion 402 of each tissue arm 400. In various embodiments, the arm knife 408 may be fabricated from, for example, stainless steel (300 or 400 series), or titanium-steel composite or ceramic, etc. and be attached to the body portion 402 of the corresponding tissue arm 400 by, depending upon the material, welding or other suitable attachment method. In the preferred embodiments, if the arm knife 408 is fabricated from any of the metal materials identified above, it may be desirable for such material to be hardened. For example, a Rockwell hardness value of 38-52 may be desirable. In alternative embodiments, the arm may be fabricated with a thin feature that could be ground to a sharp edge. As will be appreciated as the present Detailed Description proceeds, the blade works more like a scissors rather than a knife as it cuts when closed such that it shears the tissue when 408 closes against 421. As can also be seen in FIG 19, a shear plate 420 is attached to the distal end 382 of the arm shaft 380 by threaded fasteners 422 that extend into threaded fastener bores 424 in the arm shaft 380. Also in various embodiments, a plurality of tissue acquisition pins 426 are equally spaced around the circumference of the tissue acquisition shaft 380 and protrude radially therefrom. The outer edge 421 of the shear plate 420 cooperates with the cutting edges 410 on the tissue arms 400 to shear off tissue that is drawn between those edges 410, 421 as the tissue arms 400 are moved to their retracted position.

[0106] In certain implementations, a distal end post 442 protrudes from a portion of the firing shaft 350 that coaxially extends within the deployment shaft 370 for selective axial travel therein. The distal end post 442 supports a distal anvil connector 450 therein that is coupled to an adjustment knob 460 that is rotatably supported on the handle assembly 312 in the various manners discussed above.

[0107] The circular stapler 300 further includes an anvil 470 as shown in FIG. 18. In various non-limiting embodiments, the anvil 470 includes an anvil base 471 that has a series of staple forming pockets 472 therein. The anvil base 471 may further define a shear edge 473 for facilitating the shearing of tissue by the annular knife 340. The anvil 470 further includes an anvil shaft 474 that is removably attachable to the distal anvil connector 450. In particular, a coupling stem 476 protrudes from the proximal end 475 of the anvil shaft 474 and is sized to be slidably received in a passage 452 in the anvil shaft assembly 450. See

FIG. 23. The anvil assembly 470 further has an anvil cap 478 thereon that serves to define a tissue cavity 479 therein as illustrated in FIGS. 18 and 23. As can also be seen in FIG. 18, the disc-like assembly 401 is sized to extend into an opening 475 in the anvil base 471.

[0108] One exemplary method of using the circular stapler 300 will be described with reference to FIGS. 23-31. The various embodiments of the circular stapler 300 are particularly well-suited for performing a circular anastomosis of a tubular organ such as, for example, a colon 200. Turning first to FIG. 23, the stapler head 320 is inserted through the patient's anus 199 into a proximal portion 201 of the colon 200. When a diseased or otherwise targeted portion 202 of colon 200 is to be removed, the stapler head 320 is positioned in an area wherein the diseased portion 202 is to be severed from the proximal portion 201.

[0109] Once the stapler head 320 has been properly positioned within the colon, the tissue arms 400 may be radially deployed by rotating the tissue acquisition knob 310 in a first direction (represented by arrow 311 in FIG. 17) which also rotates the deployment shaft 370. Rotation of the deployment shaft 370 in the first direction also rotates the drive gear 374 which is in meshing engagement with the driven gear portions 404 of each tissue arm 400. Thus, rotation of the drive gear 374 in the first direction causes the tissue arms 400 to be radially deployed. As the tissue arms 400 are radially deployed, the tissue-piercing tips 406 thereof pierce through the proximal portion 201 of colon 200. See FIGS. 24 and 25. Once the tissue arms 400 have been deployed such that the tissue-piercing tips 406 thereof have pierced through the proximal portion 201 of colon 200, the surgeon may then rotate the tissue acquisition knob 310 in a second direction (represented by arrow 313 in FIG. 17) to move the tissue arms 400 to the retracted position. As the tissue arms 400 are retracted, they gather the pierced proximal portion 201 of colon 200 and draw it inward toward the tissue acquisition shaft 380. As the gathered colon 201 is drawn between the shear plate 420 and the tissue arms, the portion 201 of the colon 200 that is captured between the outer edge 421 of the shear plate 420 and the cutting edges 410 on the tissue arms 400 is severed from the diseased portion 202 of the colon 200. Retraction of the tissue arms 400 causes the portion 201 of the colon 200 to be impaled onto the tissue retention pins 426 and retained thereon as shown in FIG. 26. Thereafter, the diseased portion 202 of the colon 200 may be transected from the distal colon portion 208 using a conventional laparoscopic tissue severing instrument (not shown) inserted through a trocar sleeve inserted into the abdominal cavity 601. After the

diseased portion 202 has been cut away from the distal colon portion 208, the diseased portion 202 may be removed through the trocar sleeve (not shown) with a conventional grasping instrument 600. See Fig. 26.

[0110] The surgeon then orients the anvil 170 within the distal portion 208 of the colon 200 such that the anvil shaft coupling stem 476 of the anvil shaft 474 protrudes out of the distal portion 208 of the colon 200 as shown in FIG. 28. The surgeon then ties the end of the distal colon portion 208 around the anvil shaft 474 using what is known in the art as a “purse string suture” 220. Once the distal colon portion 208 has been sutured around the anvil shaft 474, the coupling stem 476 of the anvil shaft 474 is inserted into the passage 452 in the anvil shaft assembly 450. The coupling stem 476 is sized relative to the passage 152 to establish a frictional fit therebetween to retain the coupling stem 176 therein, yet permit the coupling stem 176 to be removed therefrom at a later time. See FIG. 28.

[0111] The surgeon then draws the anvil 470 toward the stapler head 420 (in the proximal direction “PD”) by rotating the anvil control knob 460 in the appropriate direction until portions 205, 210 of the colon 200 are clamped between the anvil 470 and the staple cartridge 330 as shown in FIG. 29. Thereafter, the surgeon actuates the firing trigger 360 to axially advance the firing shaft 350 in the distal direction “DD”. As firing shaft 350 is advanced distally, the staple driver portions 354, 356 serve to drive the staples 36 through the portions 205, 210 of colon 200 into the anvil forming pockets 472 in the anvil 470. The firing shaft 350 also advances the annular knife 340 through the colon portions 205, 210 to sever portions 201, 207, respectively therefrom. The surgeon may then move the anvil 470 in the distal direction “DD” to release the stapled colon portions 205, 210 from between the anvil 470 and the stapler head 320. The instrument 300 may then be removed from the colon 200. See FIG. 31. The severed portions 201, 207 of the colon 200 remain in the stapler head 320 and the anvil 470, respectively as the surgeon withdraws the instrument 300 out through the patient’s anus. Thus, the severed portions 201, 207 of the colon 200 are removed from the repaired colon when the instrument 300 is withdrawn therefrom.

[0112] Circular stapling instruments are generally introduced through the anus and not from the abdomen side of the pelvis. Such method of entry complicates the ability of the surgeon to visualize the tumor, the tumor’s necessary margins and those margin edges with respect to the distal transection location to ensure that the stapler head has been properly positioned in

the colon before commencing the transection. FIGS. 32-37 illustrate a circular stapler 700 according to various non-limiting embodiments of the invention that may provide feedback to the surgeon during the insertion process. The circular stapler 700 generally includes a handle assembly 712 that has an elongated shaft assembly 714 protruding therefrom. The elongated shaft assembly 714 may define a central axis A-A. As can be seen in FIG. 32, the elongate shaft assembly 714 includes a rigid outer sheath 716 that has a distal end portion that supports a stapler head 720 thereon. In various non-limiting embodiments, the stapler head 720 is configured to operably support a circular staple cartridge 730 therein. Such circular staple cartridges 730 are known in the art and generally may support one, two or more than two circumferentially spaced and staggered rows of staples therein. In the non-limiting embodiment depicted in Figure 33, the staple cartridge 730 supports two rows 732, 734 of staples 36 therein. A conventional annular knife 740 is coaxially and movably supported within the stapler head 720.

[0113] The circular stapler 700 further includes a firing shaft 750 that is operably supported within the rigid outer sheath 716 for selective axial travel therein. See FIG. 33. A distal end portion 752 of the firing shaft 750 has an outer staple driver portion 754 thereon for engagement with each of the staples 36 in the outer row 732 of staples 36 in the staple cartridge 730. In addition, the distal end portion 752 of the firing shaft assembly 750 has an inner staple driver portion 756 that is configured for engagement with each of the staples 36 in the inner row 734 of staples 36 within the staple cartridge 730. As can also be seen in FIG. 33, for example, the distal end portion 752 of the firing shaft 750 further has a flanged portion 758 that is configured to engage the annular knife 740. Thus, as will be discussed in further detail below, axial advancement of the firing shaft 750 in a distal direction “DD”, will cause the staples 36 to be driven out of the staple cartridge 730 as well as the annular knife 740 to advanced distally.

[0114] In various non-limiting embodiments, the firing shaft 750 interfaces with a firing trigger 60 that is operably coupled to the handle assembly 712. As can be seen in FIG. 32, the firing trigger 60 is pivotally coupled to the handle assembly 712 such that when the firing trigger 60 is pivoted toward the handle assembly 712, the firing shaft 750 is moved in the distal direction DD as was discussed above.

[0115] As shown in FIG. 33, various non-limiting embodiments include a hook and detection housing 770 that is coaxially supported within the firing shaft 750 and axially movable therein. The hook and detection housing 770 has a plurality of hook lumens 772 therein that each movably supports an acquisition hook member 780 therein. As can be seen in FIG. 34, for example, the plurality of three-sided hook lumens 772 may be equally spaced around the circumference of the hook and detection housing 770. For example, in the non-limiting embodiment depicted in FIG. 34, a total of eight (8) hook lumens 772 are equally spaced around the circumference of the hook and detection housing 770. Each hook member 780 may be fabricated from, for example, Nitinol, 300 or 400 series stainless steel (fully or three-fourths hardened), etc. and have a distal end portion 782 that, when advanced out of its respective hook lumen 772, naturally flexes or bends radially outward in the manners described above. As with other embodiments, each acquisition hook member 780 may have a tissue barb 784 formed on the distal end portion 782 thereof. As can be seen in FIGS. 33 and 34, in various non-limiting embodiments, the hook and detection housing 770 includes a hook sleeve 778 that facilitates installation of the acquisition hook members 780 into their respective lumens 772.

[0116] In various non-limiting embodiments, a proximal end portion of the hook and detection housing 770 may operably interface with a hook switch 790 that is operably supported on the handle 712. See FIG. 32. As the surgeon moves the hook switch 790 in a distal direction (arrow 792 in FIG. 32), the hook and detection housing 770 moves distally. In addition, each acquisition hook member 780 is advanced distally out of its respective hook lumen 772 as was described above. The surgeon may retract the hook members 780 into their starting positions by moving the hook switch 790 in a proximal direction (arrow 794 in FIG. 32).

[0117] Also supported within the hook and detection housing 770 are a plurality of flexible detection members 781. In particular, a plurality detection lumens 774 are also provided in the hook and detection housing 770. For example, in the non-limiting embodiment depicted in FIG. 34, a total of eight (8) detection lumens 774 are equally spaced around the circumference of the hook and detection housing 770. In one non-limiting embodiment, each detection member 781 may be fabricated from, for example, polyethylene, Nylon, Nitinol, titanium etc. and have a distal end portion 783 that, when deployed out of its respective detection lumen 774, naturally flexes or bends radially outward as illustrated in FIG. 35. In

addition, a substantially blunt or rounded bumper 785 may be provided on the distal end of each detection member 781. In one embodiment, the bumper may be fabricated from, for example, Sanoprene, Isoprene, natural rubber, polypropylene, polyethylene, Nylon, etc. In other embodiments, the bumper 785 may comprise a light or light emitting diode (LED). In those embodiments, a conductor may extend from a battery in the handle assembly 712 or other energy source through a lumen in the detection member 781 to the light 785.

[0118] In various non-limiting embodiments, a proximal end portion of each detection member 770 may interface with a detection knob 791 that is operably supported on the handle assembly 712. See FIG. 32. As the surgeon rotates the detection knob 791 in a first direction (arrow 793 in FIG. 32), the detection members 781 deploy distally out of their respective lumens in a radial direction away from central axis A-A to deployed positions (FIG. 36). In various embodiments, for example, all of the detection members 781 may be attached to a round sleeve (not shown) that is slidably supported within the outer sheath 716. The round sleeve may further have a gear rack attached thereto that is received in meshing engagement with a gear (not shown) on the underside of the detection knob 791. Rotation of the detection knob 791 in one direction moves the sleeve distally and therefore extends all of the detection members 781. When the surgeon rotates the detection knob 791 in a second direction (arrow 795 in FIG. 32), the detection members 781 are drawn back into their respective detection lumens 774 to the retracted position. See FIG. 34. Other switches and drive arrangements could also be employed to selectively extend and retract the detection members without departing from the spirit and scope of the present invention.

[0119] As can be further seen in FIG. 33, in various non-limiting embodiments, a cutter housing 800 is coaxially supported within the hook and detection housing 770. The cutter housing 800 is supported for selective axial travel relative to the hook and detection housing 770 and for selective axial travel along central axis A-A. The cutter housing 800 interfaces with a knife knob 810 that is movably supported on the handle assembly 712. See FIG. 32. In various non-limited embodiments, the knife knob 810 is supported on the handle assembly 712 such that it can move axially (represented by arrows 812, 814 in FIG. 32) and also be rotated relative to the handle assembly 712 (represented by arrow 816 in FIG. 32). The cutter housing 800 may be attached to the knife knob 810 in the various manners described above such that movement of the knife knob 810 in an axial direction moves the cutter housing 800

axially within the hook and detection housing 770 and rotation of the knife knob 810 also rotates the cutter housing 800 about the central axis A-A.

[0120] In various non-limiting embodiments, the cutter housing 800 includes a plurality of knife lumens 802 that extend axially through the wall of the cutter housing 800. As was discussed above with respect to other embodiments, the plurality of knife lumens 802 may be spaced equally around the circumference of the cutter housing 800. For example, in a non-limiting embodiment, a total of eight (8) knife lumens 802 may be equally spaced around the circumference of the cutter housing 800. As can be seen in FIG. 33, each knife lumen 802 has a curved distal end portion 804 that opens radially outward.

[0121] In various non-limiting embodiments, a flexible knife member 820 is slidably received within each knife lumen 802. Each flexible knife member 820 has a sharpened distal end 822 and a proximal end (not shown) that interfaces with a knife switch 830 that is operably mounted to the handle 712 in the various manners described above. See FIG. 32. The distal end 822 may be substantially pointed to enable it to pierce through tissue and it may have at least one cutting edge formed thereon. When the knife switch 830 is moved in the distal direction (arrow 832), the knife members 820 are moved distally within the knife lumens 802 such that the sharpened distal end 822 naturally flexes or bends radially out of the curved distal end portion 804 of the lumen 802 as was described above. Likewise, movement of the knife switch 830 in the proximal direction (represented by arrow 834 in FIG. 32), causes the knife members 820 to be retracted back into their respective knife lumen 802. In various non-limiting embodiments, the knife members 820 may be fabricated from, for example, Nitinol, 300 or 400 series stainless steel (fully of three-fourths hardened).

[0122] As can also be seen in FIG. 33, various non-limiting embodiments may further include an anvil shaft assembly 840 that is coaxially supported within the cutter housing 800 for selective axial travel therein. The anvil shaft assembly 840 may comprise a distal end post 842 that protrudes from a portion of the firing shaft firing shaft 750. The distal end post 842 supports a distal anvil connector 850 therein that that protrudes distally from the distal end post 842. The anvil shaft assembly 840 has a proximal end portion that interfaces with an adjustment knob 760 that is rotatably supported on the handle assembly 712 as was discussed above with respect to other non-limiting embodiments. The circular stapler 700 further includes an anvil 170 as shown in FIG. 32.

[0123] One exemplary method of using the circular stapler 700 will now be described. To commence the procedure, the surgeon inserts the elongated shaft 714 through the patient's anus 199 into a proximal portion 201 of the colon 200. Thereafter, the surgeon may extend the detection members 781 as illustrated in FIGS. 36 and 37 to "fine tune" the positioning of the stapler head 720. This may be accomplished by rotating the detection knob 791 in the appropriate direction. As the bumpers 785 are forced radially into the wall of colon portion 201, they create identifiable bumps or deflections 203 or irregular areas that protrude outward and provide means for the surgeon to visually observe where the stapler head 720 is located. Such identifiable features are distinct from the actual anatomy of the colon wall. The substantially blunted or rounded bumpers do not penetrate or damage the colon wall. Such bumps 203 allow the surgeon to position the stapler head 720 relative to the tumor or diseased portion 202 of the colon. If one or more of the bumpers 785 comprise lights, the surgeon may view the lights through the colon wall as indicated in FIG. 37.

[0124] Once the surgeon has located the stapler head 720 in the desired location within the proximal portion 201 of the colon 200, the surgeon may then retract the detection members 781 into the hook and detection housing 770 by rotating the detection knob 791 in a direction that is opposite to the direction in which the detection members 781 were caused to be extended. The acquisition hook members 780 may then be extended to pierce through and acquire the adjacent portions of the proximal colon wall 201. In alternative embodiments, however, the surgeon may elect to maintain the detection members 781 in their extended positions as shown in FIG. 37. In doing so, the detection members 781 may produce some "hoop stress" in the colon wall which may assist in the acquisition and piercing of the proximal colon wall 201 by the acquisition hook members 780.

[0125] To cause the acquisition hooks 780 to engage and penetrate the proximal colon portion 201, the surgeon advances the hook and detection housing 770 distally by moving the hook switch 790 in the distal direction (arrow 792 in FIG. 32). Movement of the hook and detection housing 770 in the distal direction causes the acquisition hook members 780 to move axially out of their respective hook lumens 772. As the distal ends of the acquisition hook members 780 exit their respective hook lumens 772, they move radially outward to engage and pierce through adjacent portions of the proximal colon wall 201. See FIG. 37. Once the hook members 780 have pierced and engaged the adjacent portions of the proximal colon wall 201, the surgeon moves the hook switch 790 in the proximal direction

(represented by arrow 794 in FIG. 32) to retract the acquisition hook members 780 into their respective hook lumens 772 as well as retract the hook and detection housing 770 back to its starting position. The barbs 784 on the distal ends of the acquisition hook members 780 draw the engaged portions of the proximal colon wall 201 into a position similar to the position illustrated in FIG. 9. Once the portions of the proximal colon portion 201 have been drawn into the position illustrated in FIG. 9, the surgeon may then complete the procedure by performing the same actions described above with respect to the circular stapler 10.

[0126] FIG. 38 illustrates another circular stapler 900 according to various non-limiting embodiments of the invention. The circular stapler 900 generally includes a handle assembly 912 that has an elongated shaft 914 protruding therefrom. The elongated shaft 914 may define a central axis A-A. As can be seen in FIG. 38, the elongate shaft 914 includes a rigid outer sheath 916 that has a stapler head 920 located at the distal end 917 thereof. In various non-limiting embodiments, the stapler head 920 is configured to operably support a circular staple cartridge 930 therein. Such circular staple cartridges 930 are known in the art and may generally support one, two, or more than two circumferentially spaced and staggered rows of staples 36 therein as was described hereinabove. A conventional annular knife 940 is coaxially and movably supported within the stapler head 920. See FIG. 39.

[0127] The circular stapler 900 further includes a firing shaft 950 that is supported within the rigid outer sheath 916 for selective axial travel therein. See FIG. 39. A distal end portion 952 of the firing shaft 950 has an outer staple driver portion 954 thereon for engagement with each of the staples 36 in the outer row 32 of staples 36 in the staple cartridge 930. In addition, the distal end portion 952 of the firing shaft 950 has an inner staple driver portion 956 configured for engagement with each of the staples 36 in the inner row 34 of staples 36 within the staple cartridge 930. As can also be seen in FIG. 39, for example, the distal end portion 952 of the firing shaft assembly 950 further has a flanged portion 958 that is configured to engage the annular knife 940. Thus, as will be discussed in further detail below, axial advancement of the firing shaft 950 in a distal direction "DD", will cause the staples 36 to be driven out of the staple cartridge 930 as well as the annular knife 940 to advanced distally.

[0128] In various non-limiting embodiments, the firing shaft 950 may interface with a firing trigger 960 that is operably coupled to the handle assembly 912. See FIG. 38. As can

be seen in FIG. 38, the firing trigger 960 may be pivotally coupled to the handle assembly 912 such that when the firing trigger 960 is pivoted toward the handle assembly 912, the firing shaft 950 is moved in the distal direction DD. As was discussed above, such firing trigger arrangements are known in the art and therefore will not be discussed in detail herein.

[0129] As shown in FIG. 39, various non-limiting embodiments may also include a hollow deployment shaft 970 that is coaxially supported within a hollow tissue acquisition shaft 980. The proximal end of the deployment shaft 970 is operably attached to an arm deployment knob 910 that is rotatably supported on the handle assembly 912 in the various manners described above. Thus, rotation of the arm deployment knob 910 on the handle assembly 912 will result in the rotation of the deployment shaft 970 about the central axis A-A. More specifically and with reference to FIG. 40, in various embodiments, a distal end 972 of the deployment shaft 970 protrudes through a hole 982 in the tissue acquisition shaft 980 and has a drive gear 974 attached thereto. A distal end 984 of the tissue acquisition shaft 980 is configured to operably support at least one tissue acquisition member or arm 1000 thereon. Two or more tissue arms 1000 are preferable. In the non-limiting embodiment depicted in FIG. 40, a total of four tissue arms 1000 are pivotally pinned to the distal end 984 of the tissue acquisition shaft 980 by corresponding pins 986.

[0130] Each tissue arm 1000 may have a body portion 1002 that may be fabricated from, for example, stainless steel (300 or 400 series), titanium, titanium-steel composite, ceramic, etc. and have a driven gear 1004 attached thereto or formed thereon. The driven gear 1004 of each tissue arm 1000 is movably supported within a corresponding arm cavity 988 formed in the distal end 984 of the tissue acquisition shaft 980. Each driven gear 1004 is in meshing engagement with the drive gear 974 on the deployment shaft 970. Thus, rotation of the deployment shaft 970 will result in the pivotal deployment of the tissue arms 1000 from the retracted position depicted in FIG. 41 to the deployed position depicted in FIG. 42. In various embodiments, the body portion 1002 of each tissue arm 1000 may further have a tissue piercing tip 1006 formed thereon or otherwise attached thereto.

[0131] In various embodiments, a knife shaft 1010 is coaxially received within the deployment shaft 970 and interfaces with a knife knob 1020 (FIG. 38) rotatably supported on the handle assembly 912 such that rotation of the knife knob 1020 results in the rotation of the knife shaft 1010. The knife shaft 1010 further has a distal end 1012 that protrudes out of

the distal ends 972, 984 of the deployment shaft 970 and the tissue acquisition shaft 980, respectively. See FIG. 40. A knife 1030 may be removably attached to the distal end 1012 of the knife shaft 1010 by, for example, pins 1032 or other suitable fasteners. In various embodiments, the knife 1030 may be substantially planar and have diametrically opposed tissue-piercing points 1031, 1033 formed thereon as shown in FIG. 40.

[0132] As can also be seen in FIG. 39, various non-limiting embodiments may further include an anvil shaft assembly 440 that includes a distal end post 442 that protrudes from a portion of the firing shaft 950 that coaxially extends within the deployment shaft 970 for selective axial travel therein. The distal end post 442 supports a distal anvil connector 450 therein that is coupled to an adjustment knob 460 that is rotatably supported on the handle assembly 312 in the various manners discussed above.

[0133] The circular stapler 900 further includes an anvil 470 as shown in FIG. 39. In various non-limiting embodiments, the anvil 470 includes an anvil base 471 that has a series of staple forming pockets 472 therein. The anvil base 471 may further define a shear edge 473 for facilitating the shearing of tissue by the annular knife 940. The anvil 470 may further include an anvil shaft 474 that is removably attachable to the distal anvil connector 450. In particular, a coupling stem 476 protrudes from the proximal end 475 of the anvil shaft 474 and is sized to be slidably received in a passage 452 in the anvil shaft assembly 450. The anvil 470 may further have an anvil cap 478 thereon that serves to define a tissue cavity 479 therein as illustrated in FIG. 39.

[0134] One exemplary method of using the circular stapler 900 will be described with reference to FIGS. 39 and 43-51. Turning first to FIG. 39, the stapler head 920 is inserted into a tubular organ such as the colon 200 through the patient's anus 199. The stapler head 920 is located in the proximal portion 201 of the colon 200 that is adjacent to a diseased portion 202. Thereafter, the tissue arms 1000 are radially deployed by rotating the arm deployment knob 910 in a first direction (represented by arrow 911 in FIG. 38) which also rotates the deployment shaft 970. Rotation of the deployment shaft 970 in the first direction also rotates the drive gear 974 which is in meshing engagement with the driven gear portions 1004 of each tissue arm 1000. Thus, rotation of the drive gear 974 in the first direction causes the tissue arms 1000 to be radially deployed. As the tissue arms 1000 are radially deployed, the tissue piercing tips 1006 thereof pierce through proximal portion 201 of the

colon 200. See FIGS. 44 and 45. The surgeon may then rotate the arm deployment knob 910 in the opposite or second direction (represented by arrow 913 in FIG. 38) to retract the tissue arms 1000 into their retracted position (FIG. 20). As the tissue arms 1000 are retracted, the pierced proximal portion 201 of the colon 200 is carried by the tissue arms 1000 such that the portion 201 is gathered between the tissue arms 1000 and the arm shaft 980 in a confronting position adjacent the staple cartridge 930. Thereafter, the surgeon may rotate the knife knob 1020 to cause the knife 1030 to rotate and sever the diseased portion 202 of the colon 200 from the proximal portion of the colon 201. The diseased portion 202 may be transected from a distal portion 208 of the colon using a conventional laparoscopic tissue severing instrument (not shown) inserted through a trocar sleeve (not shown) positioned in the abdominal cavity 601. After the diseased portion 202 has been cut away from the proximal portion 201 of the colon 200 and the distal portion 208, the diseased portion 202 may be removed through the trocar sleeve with a conventional grasping instrument 600. See FIG. 48.

[0135] The surgeon may then orient the anvil 470 within the distal portion 208 of the colon 200 such that the anvil shaft coupling stem 476 of the anvil shaft 474 protrudes out of the distal portion 208 of the colon 200 as shown in FIG. 49. The surgeon may then tie the end of the distal colon portion 208 around the anvil shaft 474 using what is known in the art as a “purse string suture” 220. Once the distal colon portion 208 has been sutured around the anvil shaft, 474, the coupling stem 476 of the anvil shaft 474 is inserted into the passage 452 in the anvil shaft assembly 450. The coupling stem 476 may be sized relative to the passage 452 to establish a frictional fit therebetween to retain the coupling stem 476 therein, yet permit the coupling stem 476 to be removed therefrom at a later time. See FIG. 49.

[0136] The surgeon then draws the anvil 470 toward the stapler head 920 (in the proximal direction “PD”) by rotating the anvil control knob 460 in the appropriate direction until portions 205, 210 of the colon 200 are clamped between the anvil 470 and the staple cartridge 930 as shown in FIG. 50. Thereafter, the surgeon actuates the firing trigger 960 to axially advance the firing shaft 950 in the distal direction “DD”. As firing shaft 950 is advanced distally, the staple driver portion 954 serves to drive the staples 36 through the portions 205, 210 of colon 200 into the anvil forming pockets 472 in the anvil base 471. The firing shaft 950 also advances the annular knife 940 to sever the colon portions 201, 207 from colon portions 205, 210 respectively. The surgeon may then move the anvil 470 in the distal direction “DD” to release the stapled colon portions 205, 210 from between the anvil 470 and

the stapler head 920. The instrument 900 may then be removed from the colon 200. See FIG. 51. The severed portion 207 is captured in the anvil cavity 479 and the severed portion 201 is retained between the tissue arms 1000 and the arm shaft 980. Thus, the cut portions 201, 207 of the colon 200 are removed from the repaired colon when the instrument 900 is withdrawn therefrom.

[0137] As the surgeon performs the above described procedures or other related procedures in that region of the body, care has to be taken to avoid inadvertently damaging adjacent soft tissues and bone structures. FIGS. 52 and 53 illustrate some of the adjacent tissue and bone structures that are adjacent to the colon 200. In FIG. 52, the peritoneum 1100 has been dissected to illustrate, for example, the sphincter ani 1101, the sacrotuberous ligament 1102, the ischtal tuberosity 1104, the ischioanal fossa 1106, levator ani 1108, and the third sacral vertebra 1110. FIG. 53 further illustrates the para rectal fossa 1112, the sacrogenital fold 1114, the ureter 1116, the ductus deferens 1118, the bladder 1120, the paravesical fossa 1122, and the transvesical folds 1124. The surgeon must also be careful not to damage the muscles, nerves, vessels and arteries along the inter wall of the peritoneum 1100 when accessing the portion of the colon 200 to be transected.

[0138] FIGS. 54-57 illustrate use of a protective sheath 1200 of a non-limiting embodiment of the present invention. In various embodiments, the sheath 1200 may be fabricated from, for example, Kevlar, polyethylene, Nylon, etc. and be stressed in a fashion that naturally makes it want to coil. See FIG. 55. In various embodiments, measurement or reference indicia 1202 may be provided on the sheath 1200 to assist the surgeon in locating the operable portion of a surgical instrument (e.g., the stapler head of a circular stapler) and to prevent accidental damage of adjacent nerves, vessels and tissue. In still other embodiments, the sheath 1200 may be fabricated from a magnetic sensitive film that would enable it to be magnetically attracted to the operable portion of the instrument to protect the adjacent anatomical structures and tissues from, for example, portions of the instrument that might damage adjacent tissues, muscles, bones, nerves, etc. if the instrument portions were brought into inadvertent contact therewith. In further alternative embodiments, the sheath 1200 may have a magnetic interaction ring or portion that is attracted to the stapler head. Thus, at least a portion of the sheath 1200 may be magnetic or otherwise have magnetic material attached thereto.

[0139] The sheath 1200 may be installed through a cannula 1252 of a conventional trocar 1250 that is laparoscopically inserted through the abdominal wall into the abdominal cavity as shown in FIG. 54. A conventional laparoscopic grasping instrument 600 may be used as shown in FIGS. 54 and 55 to remove the sheath 1200 from the trocar cannula 1252. Thereafter, the surgeon may wrap the unrolled sheath 1200 around the colon 200 using conventional grasping devices 600 as shown in FIG. 56. FIG. 57 illustrates the sheath 1200 after it has been wrapped around the colon 200 and prior to commencing insertion of the circular stapling instrument into the colon. The natural coiling nature of the sheath serves to retain it in a coiled orientation about the colon 200.

[0140] The sheath 1200 of the present invention may be effectively employed to protect adjacent tissues and organs during use of any of the above-mentioned embodiments. See, for example, FIGS. 5-16, 23-31, 36, 39, and 43-51, wherein the sheath 1200 has been installed around the colon 200 in the above-described manner. In addition, the non-limiting embodiments of the sheath 1200 may be effectively used in connection with conventional circular stapling devices and the like without departing from the spirit and scope of the present invention. For those instrument embodiments that employ lights on the detection members or the like, the sheath 1200 may be fabricated from, for example, light sensitive film that would cause portions of the sheath 1200 to change color in those areas adjacent to the lighted detection members. See For example, the non-limiting embodiment depicted in FIG. 36.

[0141] The various embodiments of the present invention represent a vast improvement over prior circular staple arrangements and procedures associated therewith. While several embodiments of the invention have been described, it should be apparent, however, that various modifications, alterations and adaptations to those embodiments may occur to persons skilled in the art with the attainment of some or all of the advantages of the invention. For example, according to various embodiments, a single component may be replaced by multiple components, and multiple components may be replaced by a single component, to perform a given function or functions. This application is therefore intended to cover all such modifications, alterations and adaptations without departing from the scope and spirit of the disclosed invention as defined by the appended claims.

[0142] Any patent, publication, or other disclosure material, in whole or in part, that is said to be incorporated by reference herein is incorporated herein only to the extent that the incorporated materials does not conflict with existing definitions, statements, or other disclosure material set forth in this disclosure. As such, and to the extent necessary, the disclosure as explicitly set forth herein supersedes any conflicting material incorporated herein by reference. Any material, or portion thereof, that is said to be incorporated by reference herein, but which conflicts with existing definitions, statements, or other disclosure material set forth herein will only be incorporated to the extent that no conflict arises between that incorporated material and the existing disclosure material.

[0143] The invention which is intended to be protected is not to be construed as limited to the particular embodiments disclosed. The embodiments are therefore to be regarded as illustrative rather than restrictive. Variations and changes may be made by others without departing from the spirit of the present invention. Accordingly, it is expressly intended that all such equivalents, variations and changes which fall within the spirit and scope of the present invention as defined in the claims be embraced thereby.

What is claimed is:

1. A surgical instrument comprising:
an elongated shaft defining a central axis and having a distal end portion configured to operably support a circular staple cartridge therein;
at least one detection member operably supported within said elongated shaft, each detection member having a distal portion that is radially deployable away from said central axis upon application of a deployment motion thereto; and
a light on said distal portion of said detection member.
2. The surgical instrument of claim 1 wherein each said detection member is movably supported in a detection and acquisition housing that is movably supported within said elongated shaft.
3. The surgical instrument of claim 1 wherein said distal portion of each said detection member naturally bends radially away from said central axis when said distal portion is axially advanced out of a distal end of said detection and acquisition housing.
4. The surgical instrument of claim 1 further comprising:
at least one acquisition member operably supported within said elongated shaft, each said acquisition member having a tissue-piercing distal portion that is radially deployable away from said central axis upon application of a deployment motion to said acquisition member; and
at least one flexible knife member movably supported in said elongated shaft, each said knife member having a distal cutting portion that is axially advanceable out of said distal end portion of said elongated shaft upon application of an axial actuation motion thereto, each said knife member being selectively rotatable about said central axis upon application of a rotary actuation motion thereto.
5. The surgical instrument of claim 4 further comprising a tissue piercing barb on said tissue-piercing distal portion of each said acquisition member.

6. The surgical instrument of claim 4 wherein each said knife member has a tissue-piercing point formed thereon.
7. The surgical instrument of claim 1 further comprising an annular cutting member that is supported by said distal end of said elongated shaft for selective axial travel relative thereto.
8. The surgical instrument of claim 7 wherein said annular cutting member is supported to receive axial firing motions from a firing member operably supported in said elongated shaft.
9. The surgical instrument of claim 1 wherein said at least one acquisition member comprises a plurality of acquisition members.
10. The surgical instrument of claim 1 wherein said at least one knife members comprises a plurality of knife members.
11. A surgical instrument comprising:
 - an elongated shaft defining a central axis and having a distal end portion configured to operably support a circular staple cartridge therein;
 - at least one detection member operably supported within said elongated shaft, each detection member having a distal portion that is radially deployable away from said central axis upon application of a deployment motion thereto; and
 - at least one acquisition member operably supported within said elongated shaft, each said acquisition member having a tissue-piercing distal portion that is radially deployable away from said central axis upon application of a deployment motion to said acquisition member.
12. The surgical instrument of claim 11 further comprising at least one flexible knife member movably supported in said elongated shaft, each said knife member having a distal cutting portion that is axially advanceable out of said distal end portion of said elongated shaft upon application of an axial actuation motion thereto, each said knife member

being selectively rotatable about said central axis upon application of a rotary actuation motion thereto.

13. The surgical instrument of claim 11 wherein each said detection member has a blunted distal end portion.

14. The surgical instrument of claim 12 further comprising a light on said distal portion of said detection member.

15. A surgical instrument comprising:
an elongated shaft defining a central axis and having a distal end portion configured to operably support a circular staple cartridge therein;

at least one detection member operably supported within said elongated shaft, each detection member having a distal portion that is radially deployable away from said central axis upon application of a deployment motion thereto; and

at least one flexible knife member movably supported in said elongated shaft, each said knife member having a distal cutting portion that is axially advanceable out of said distal end portion of said elongated shaft upon application of an axial actuation motion thereto, each said knife member being selectively rotatable about said central axis upon application of a rotary actuation motion thereto.

16. The surgical instrument of claim 15 wherein each said detection member has a blunted distal end portion.

17. The surgical instrument of claim 15 further comprising a light on said distal portion of said detection member.

18. A surgical procedure for treating a tubular organ, said surgical procedure comprising:

inserting a circular stapler head of a surgical instrument into the tubular organ;

deploying at least one lighted detection member operably supported by the surgical instrument from a retracted position to a deployed position adjacent a wall of the tubular organ; and

observing light from the lighted detection member through the organ wall to assess the location of the circular stapler head within the tubular organ.

19. The surgical procedure of claim 18 wherein said deploying the at least one lighted detection member from a retracted position to a deployed position comprises radially advancing the lighted detection member into the organ wall to create observable deflections in the organ wall.

20. The surgical procedure of claim 18 further comprising:
retracting each lighted detection member into the retracted position;
puncturing through a proximal portion of the tubular organ with a plurality of tissue acquisition members of the surgical instrument;
positioning the punctured proximal portion of the tubular organ adjacent to the stapler head;
severing the punctured proximal portion of the tubular organ from a distal portion of the tubular organ;
inserting an anvil into the distal portion of the tubular organ such that a connection portion of the anvil protrudes proximally out of an open end of the distal portion of the tubular organ;
securing the distal portion of the tubular organ to the anvil;
coupling the connection portion of the anvil to the surgical instrument;
drawing the anvil proximally toward the stapler head such that another portion of the distal portion of the tubular organ and the punctured proximal portion of the tubular organ are adjacent to each other and captured between the anvil and the stapler head;
stapling the another portion and the punctured proximal portion together; and
cutting through the another portion and punctured proximal portion adjacent to the staples.

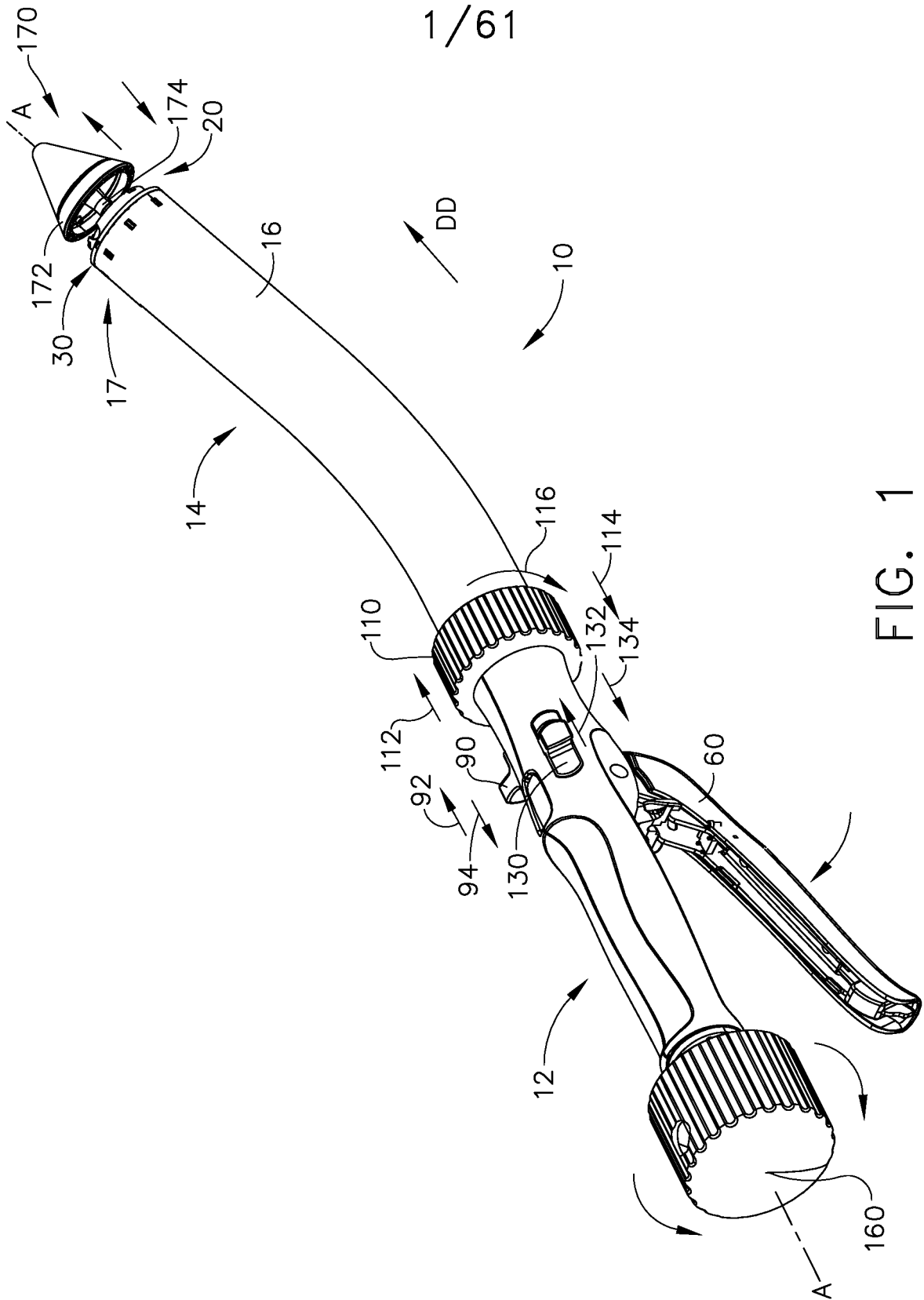

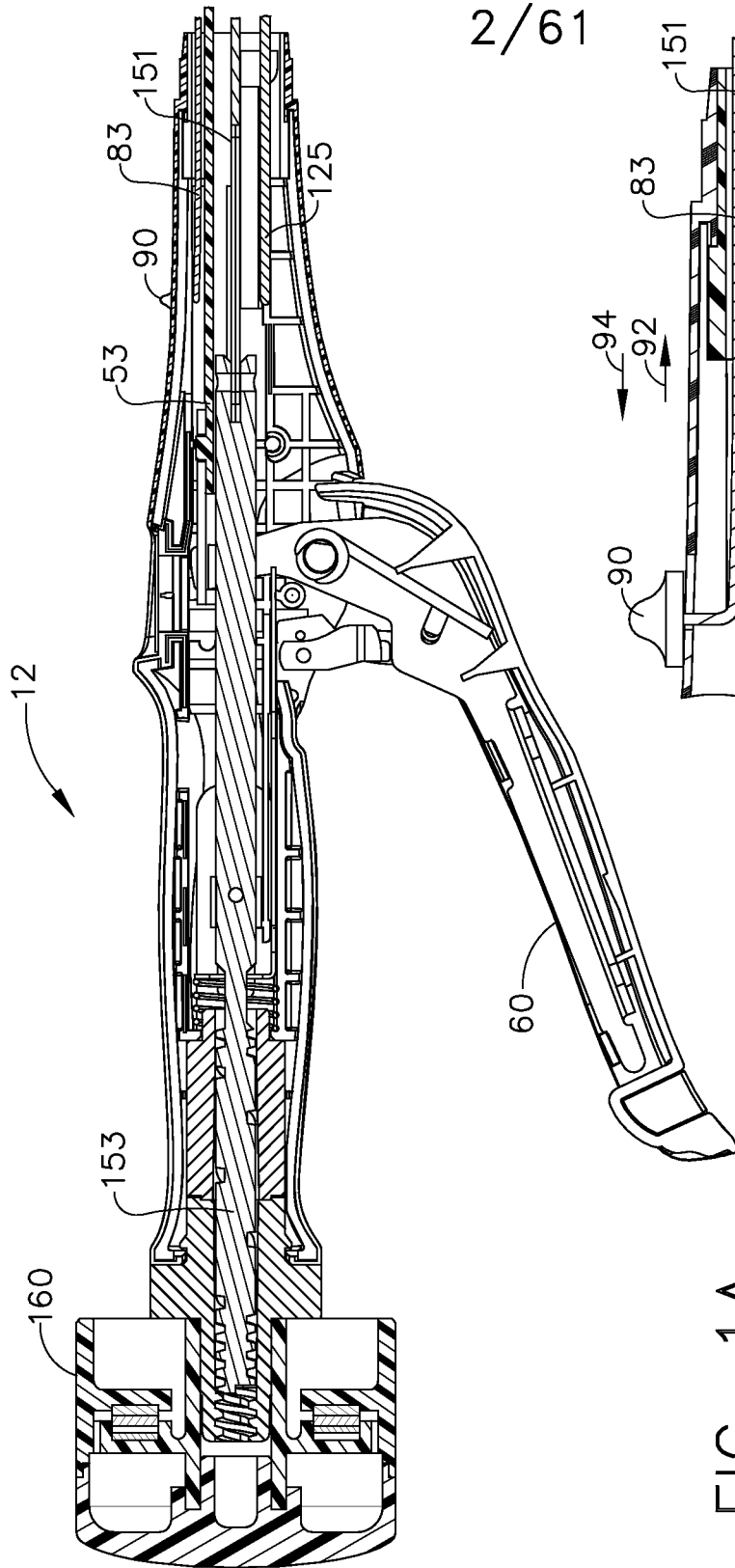

FIG. 1A

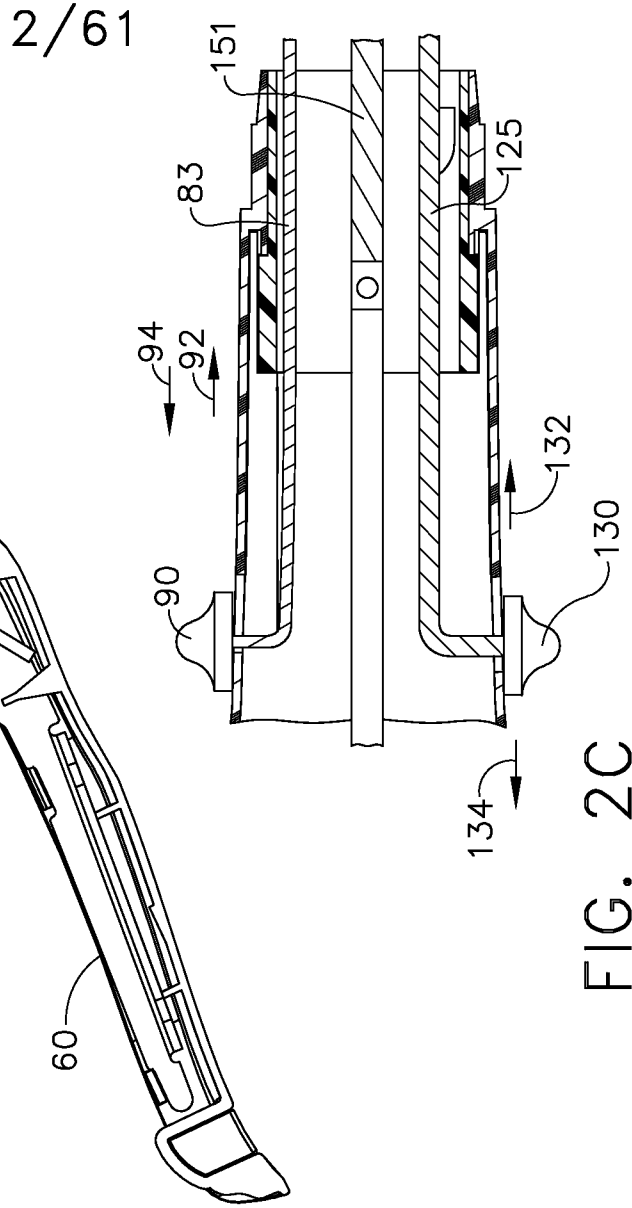

FIG. 2C

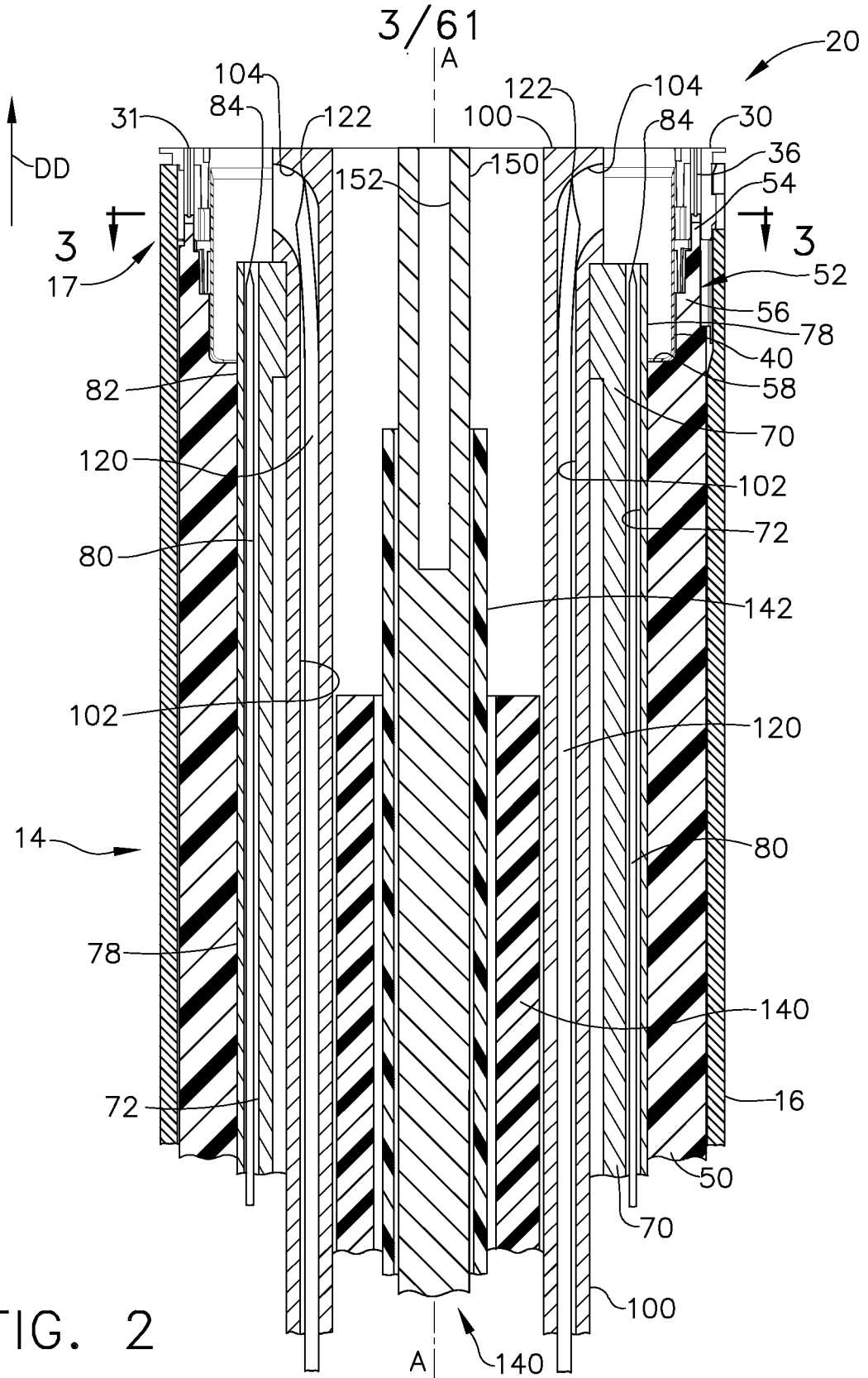

FIG. 2

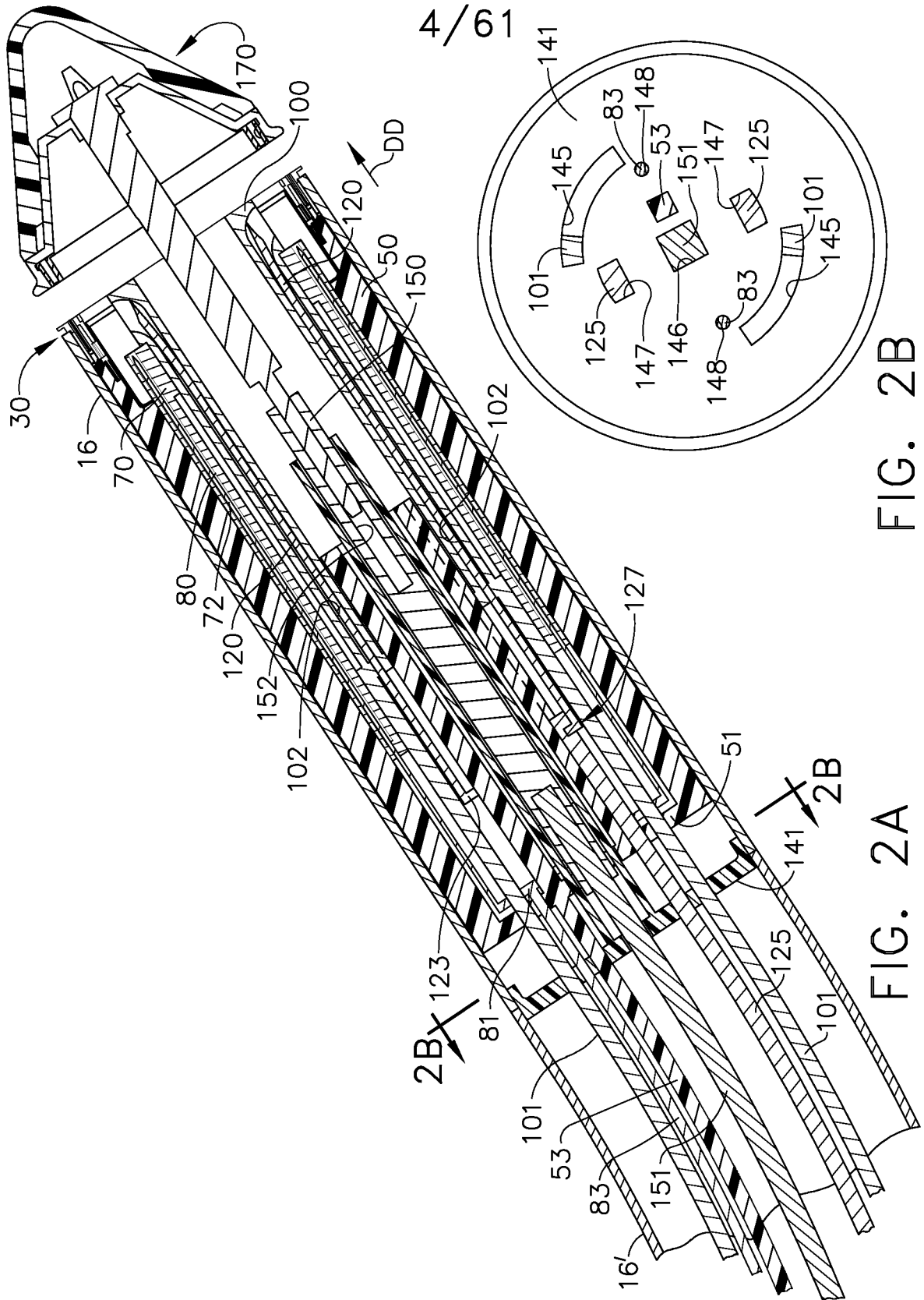

FIG. 2A

FIG. 2B

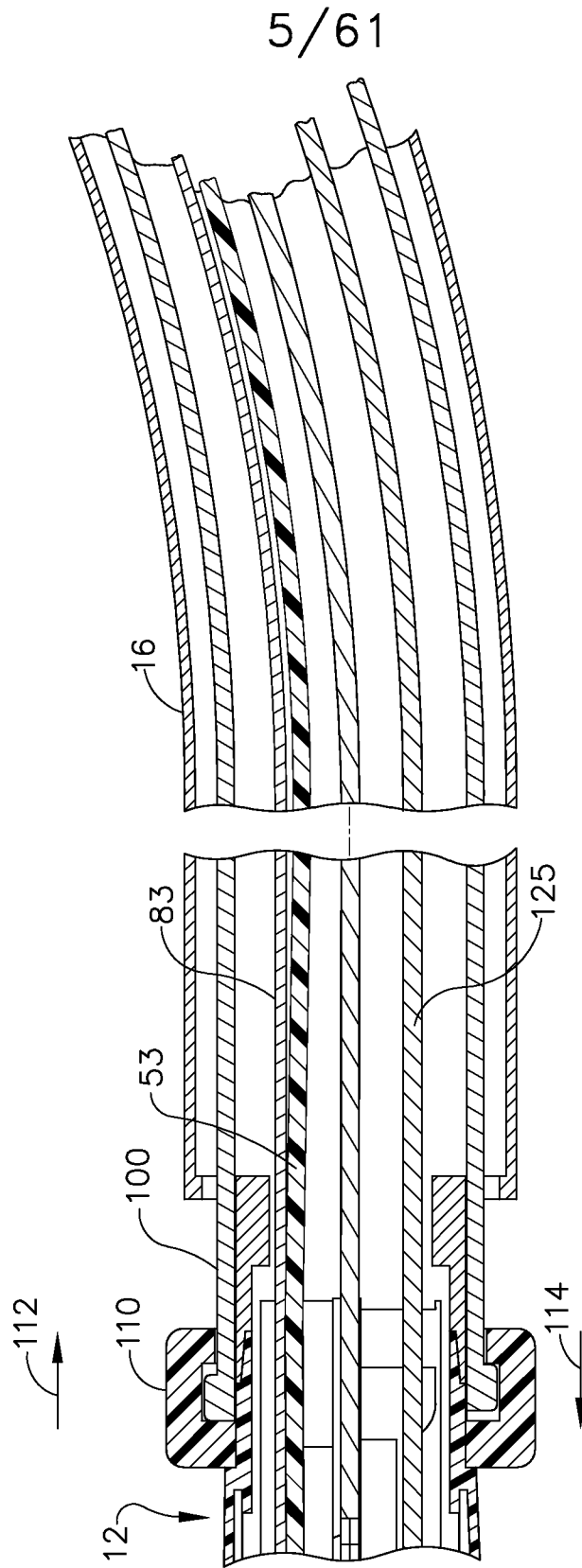

FIG. 2D

6/61

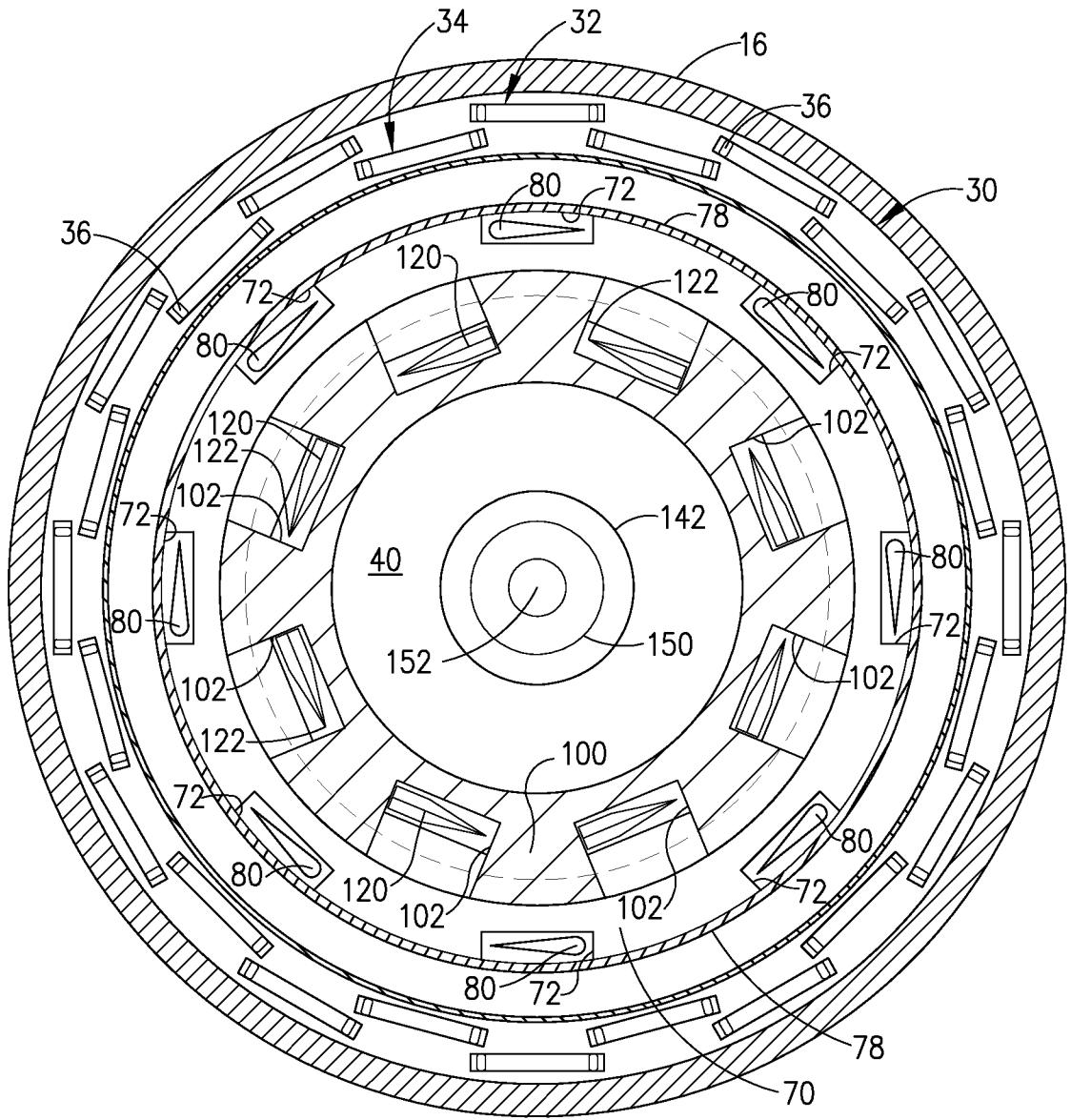

FIG. 3

7/61

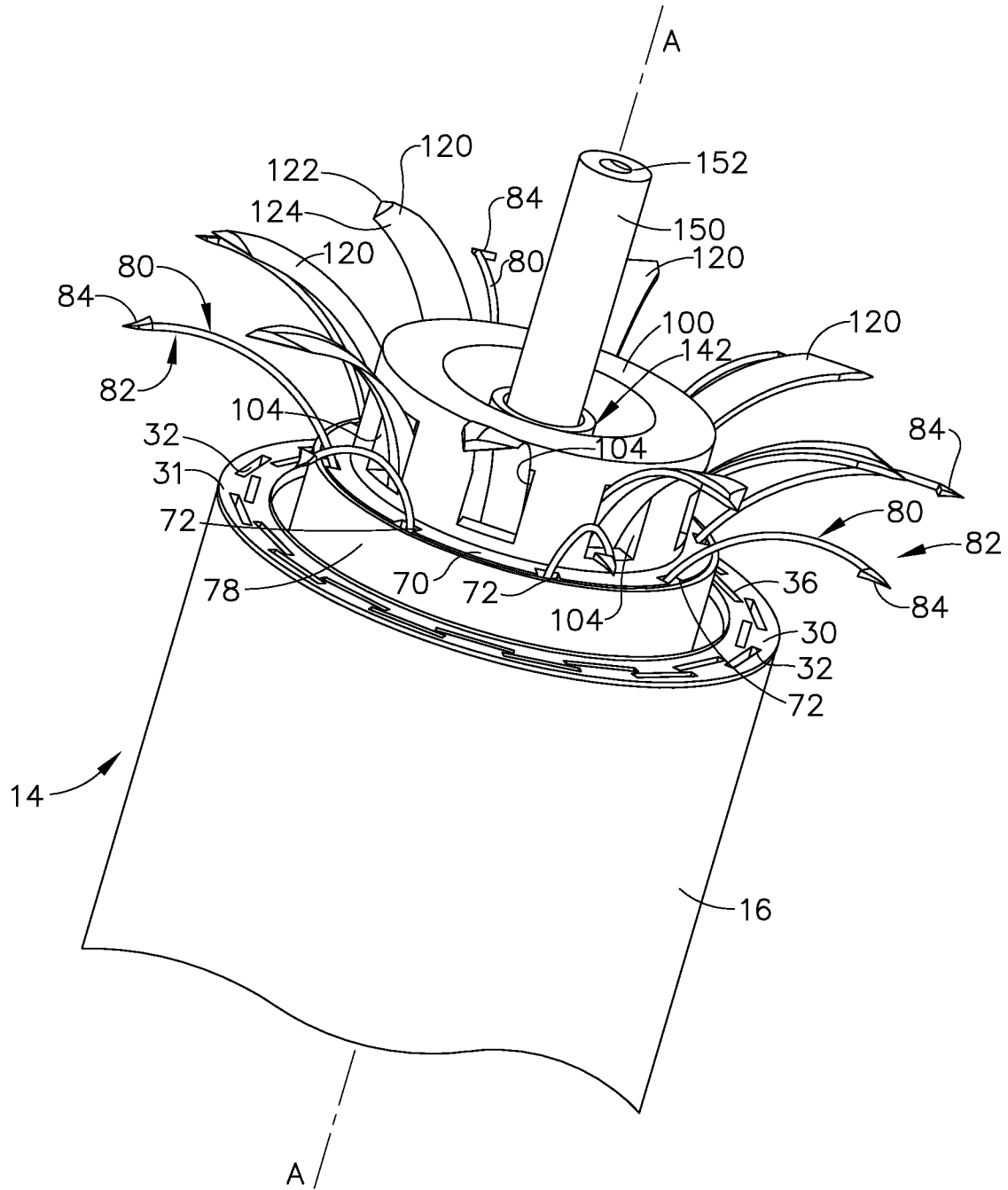
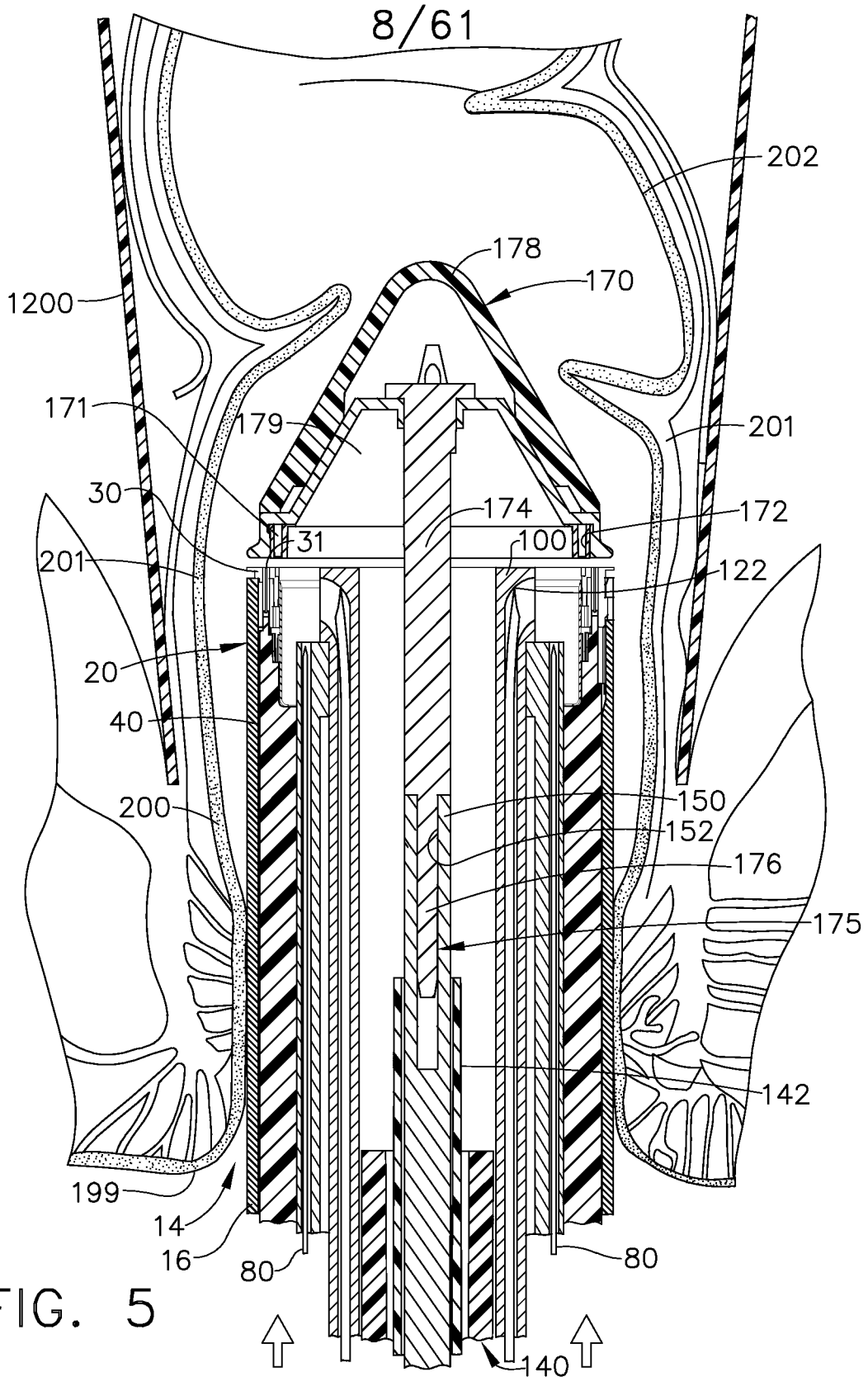

FIG. 4



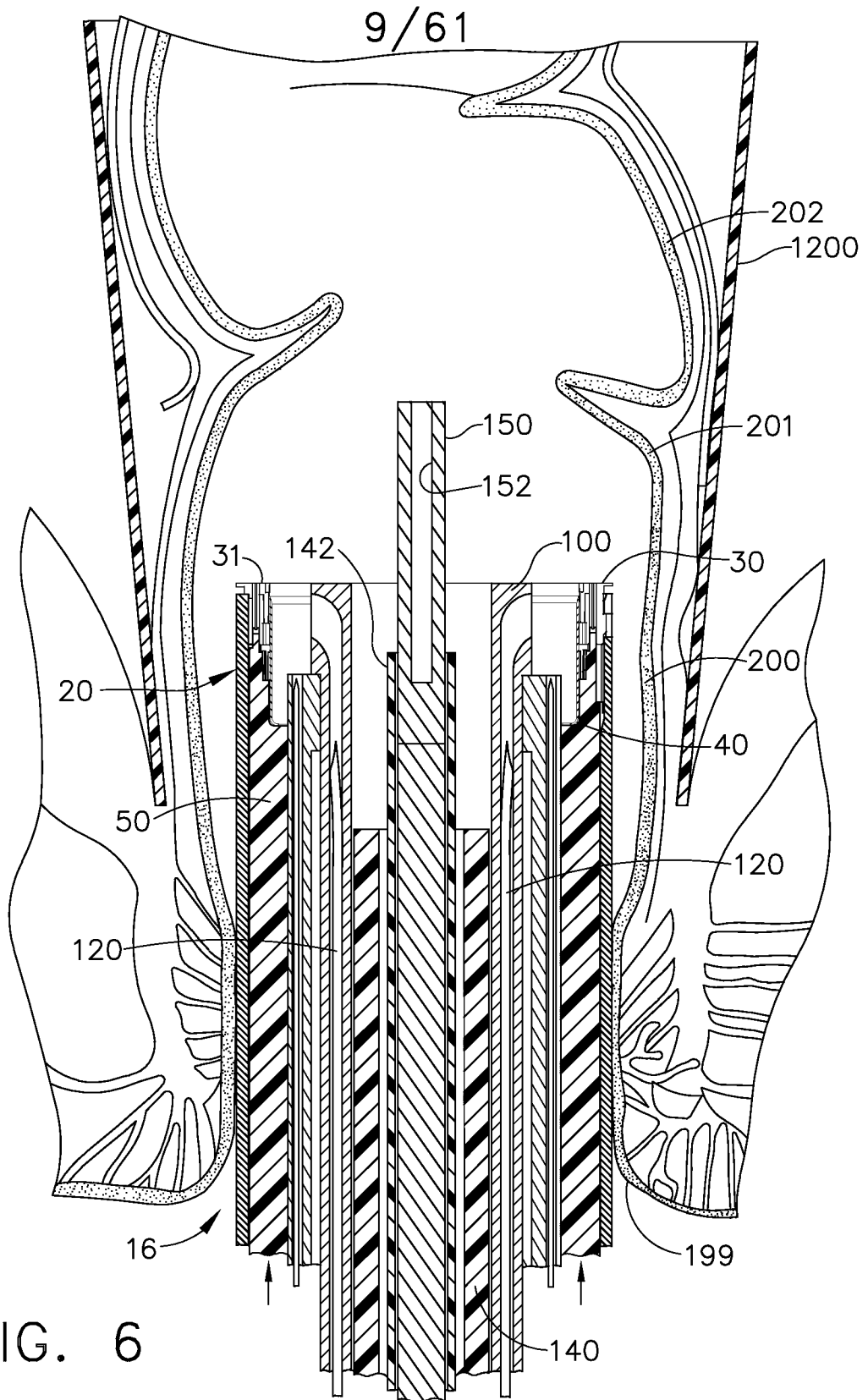

FIG. 6

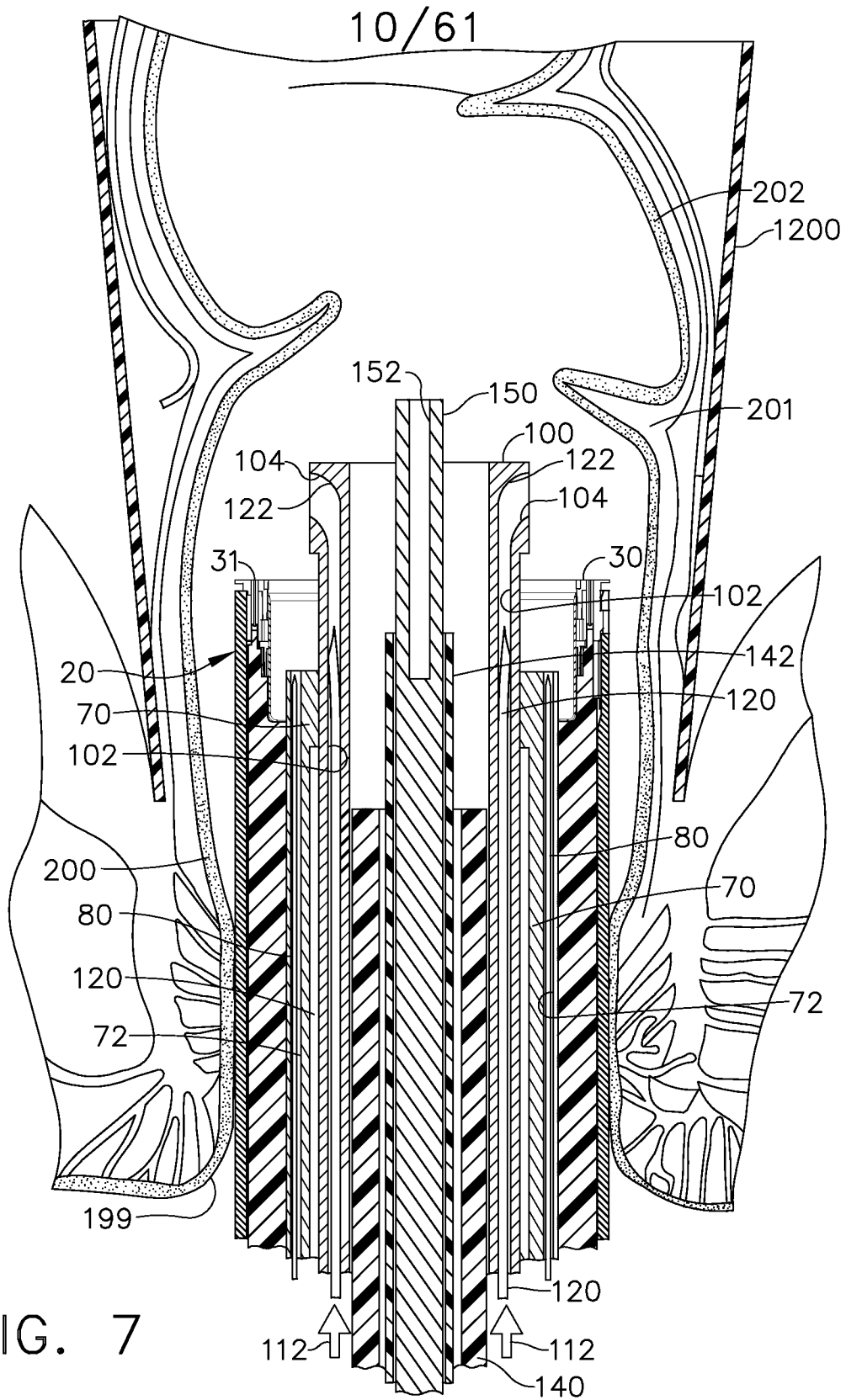

FIG. 7

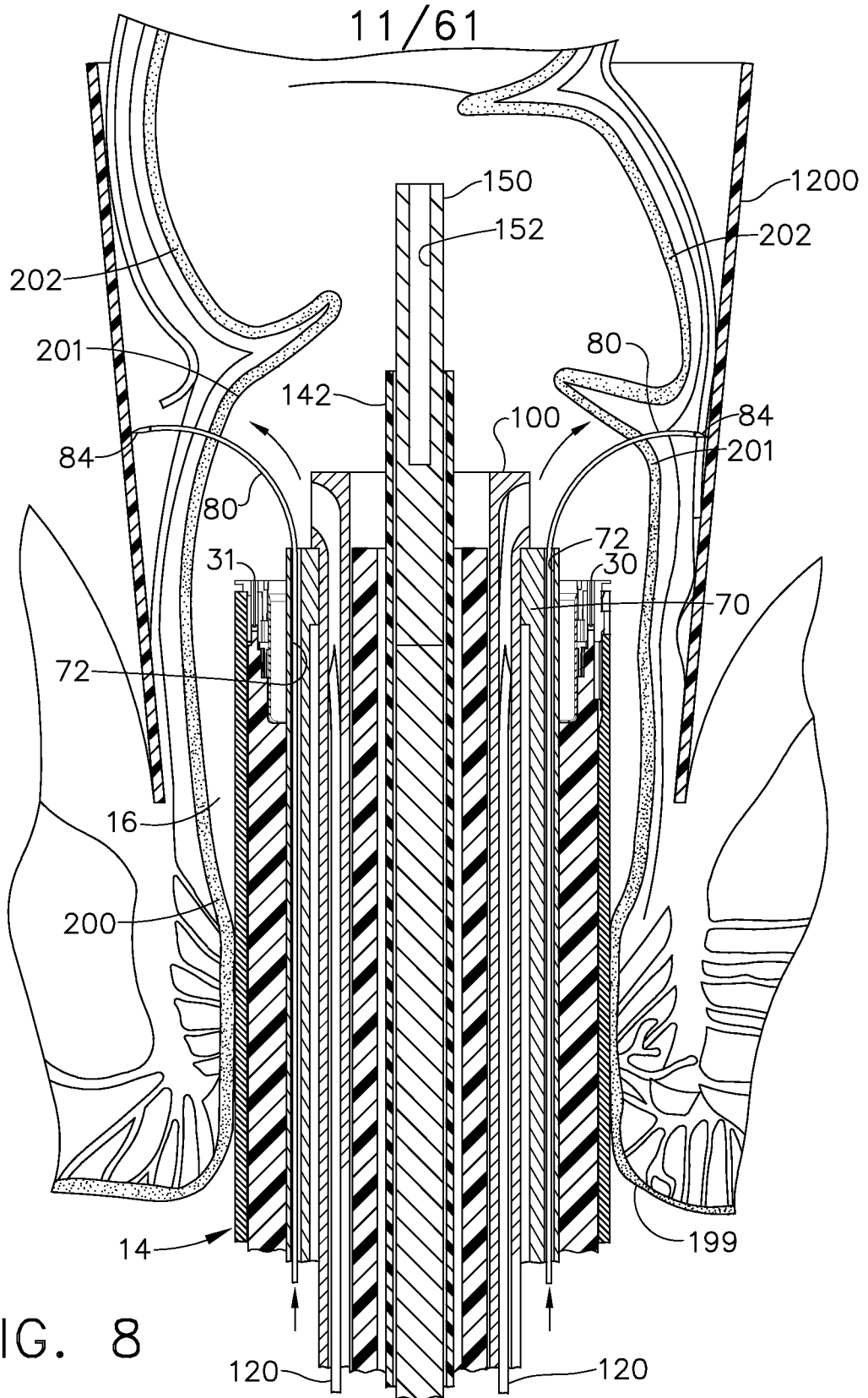

FIG. 8

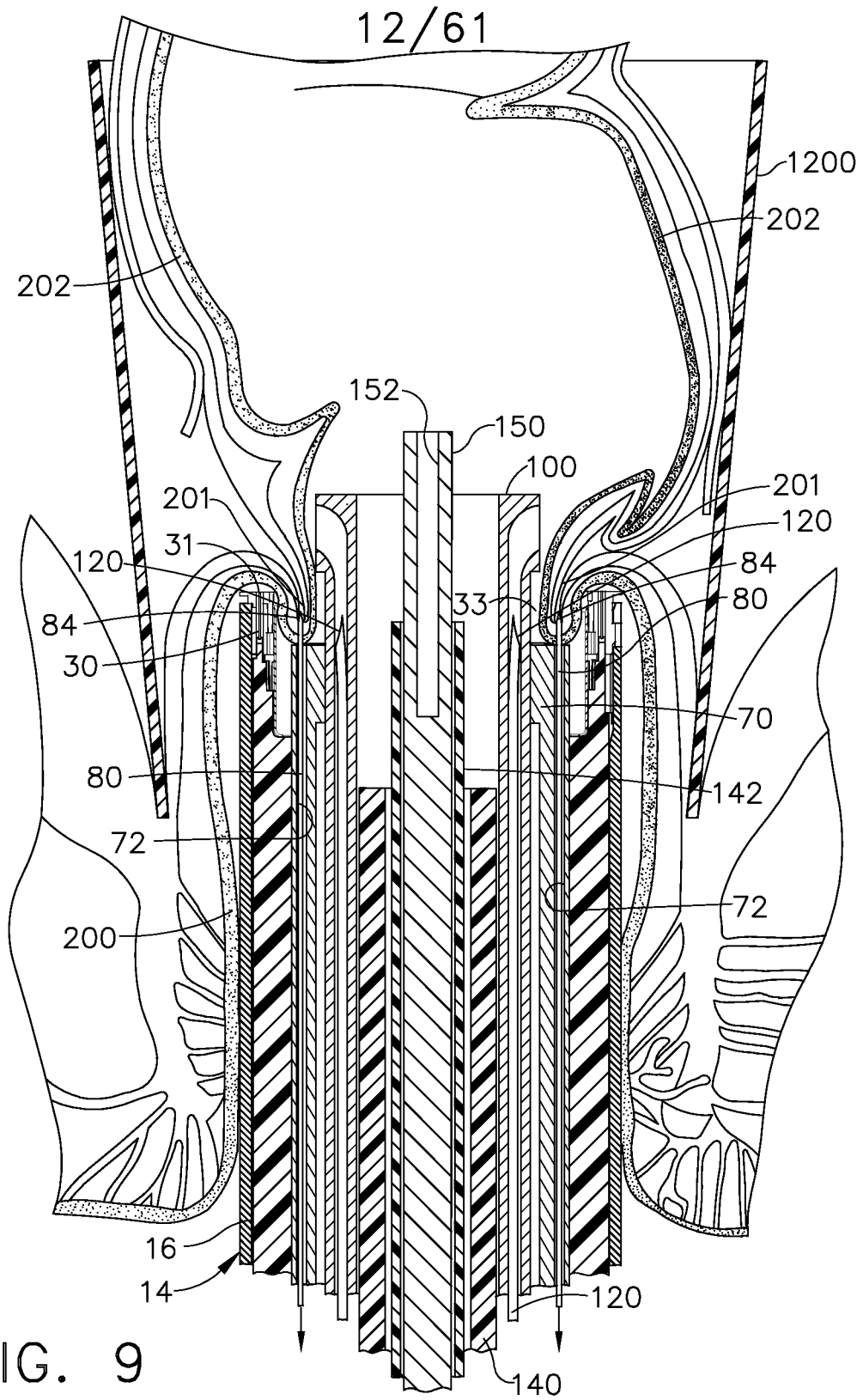

FIG. 9

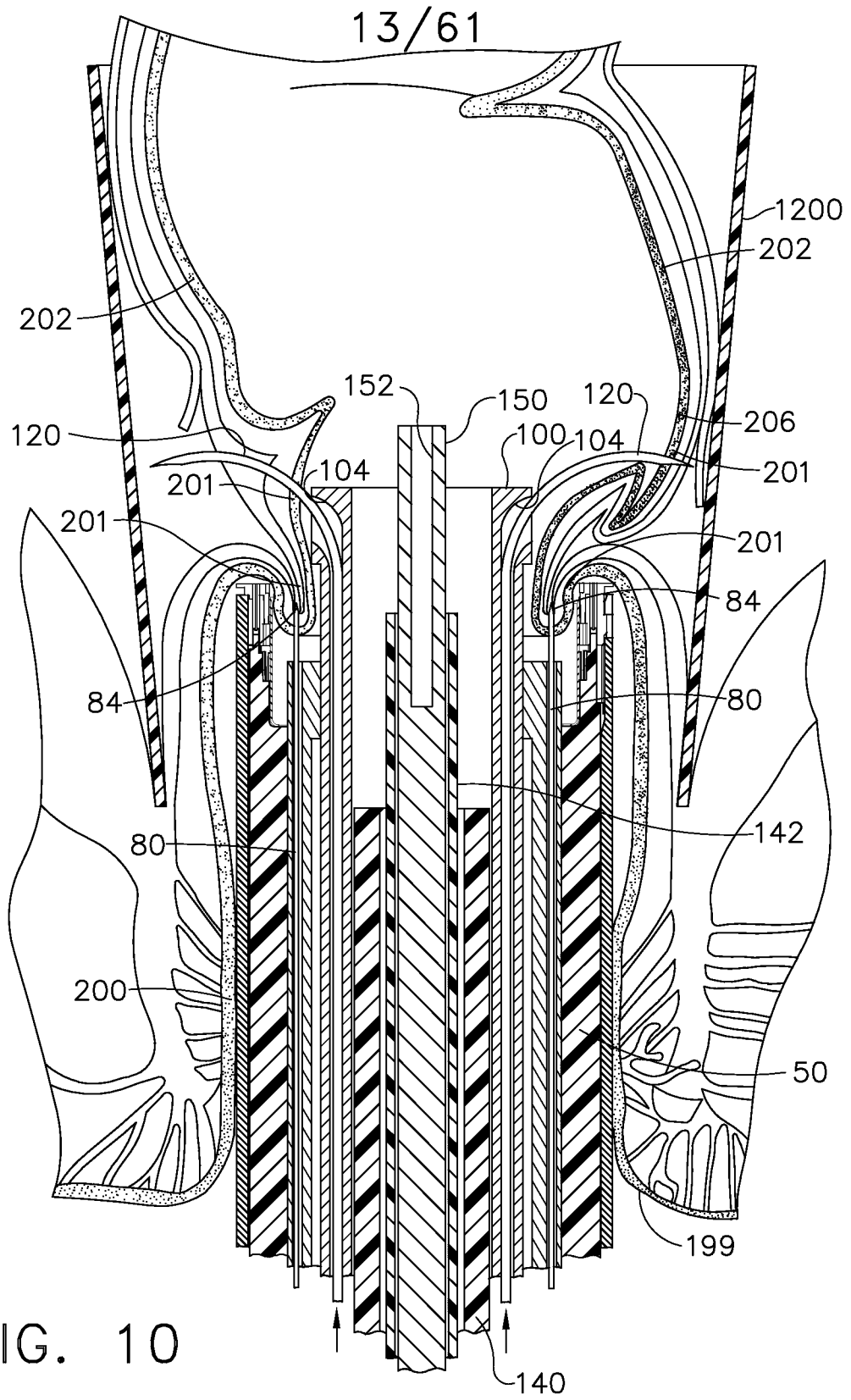
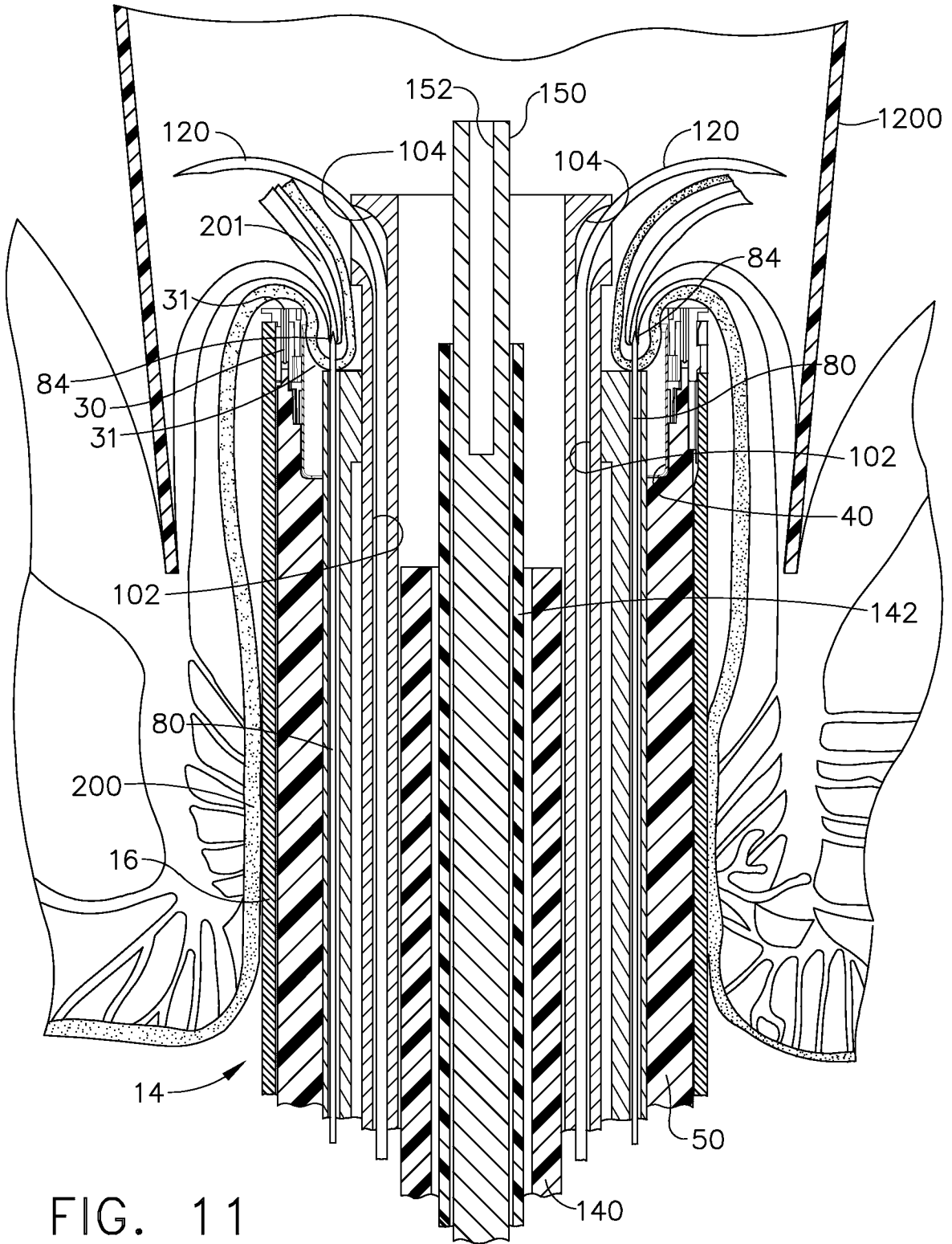
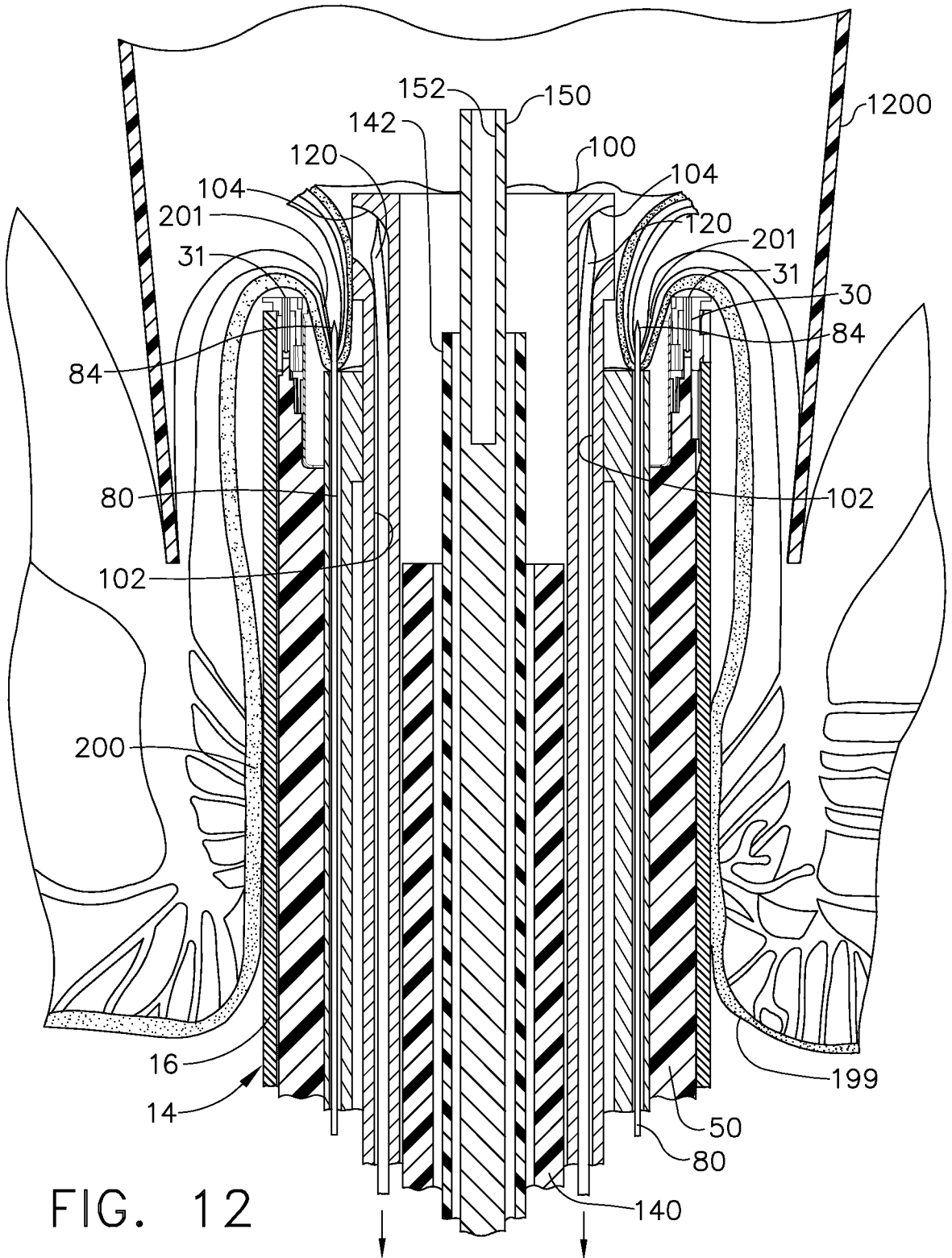

FIG. 10

14/61



15/61



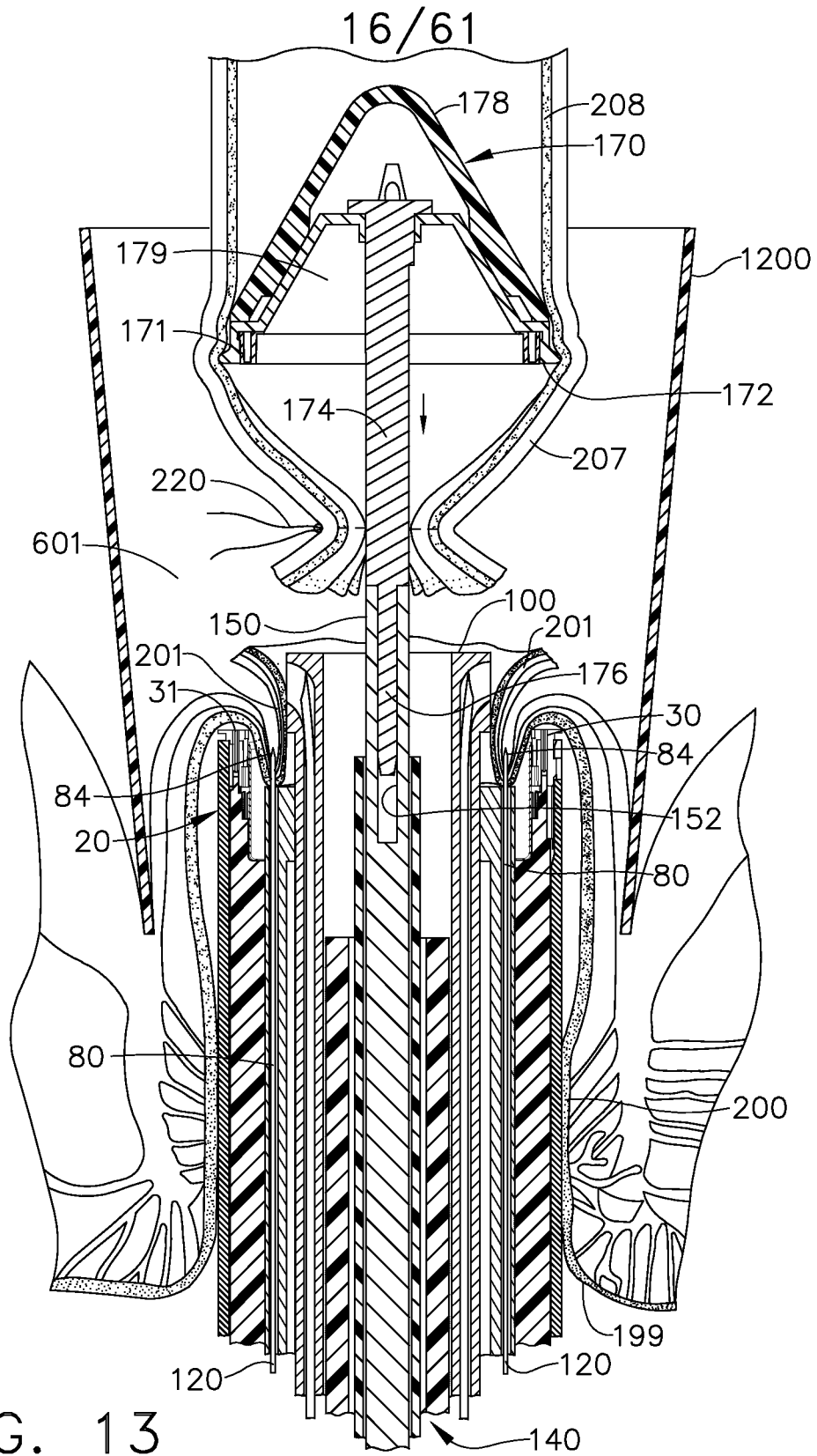

FIG. 13

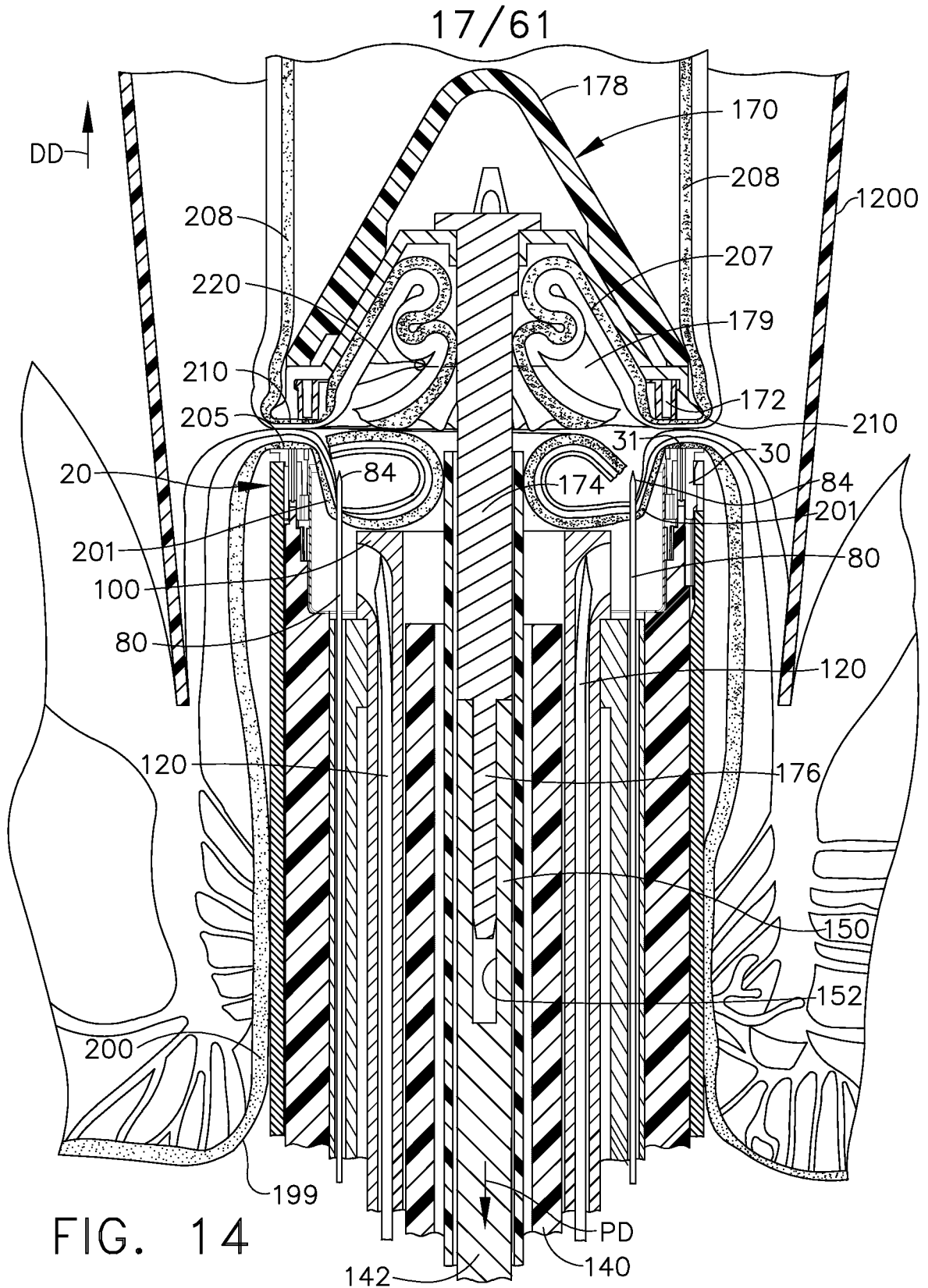
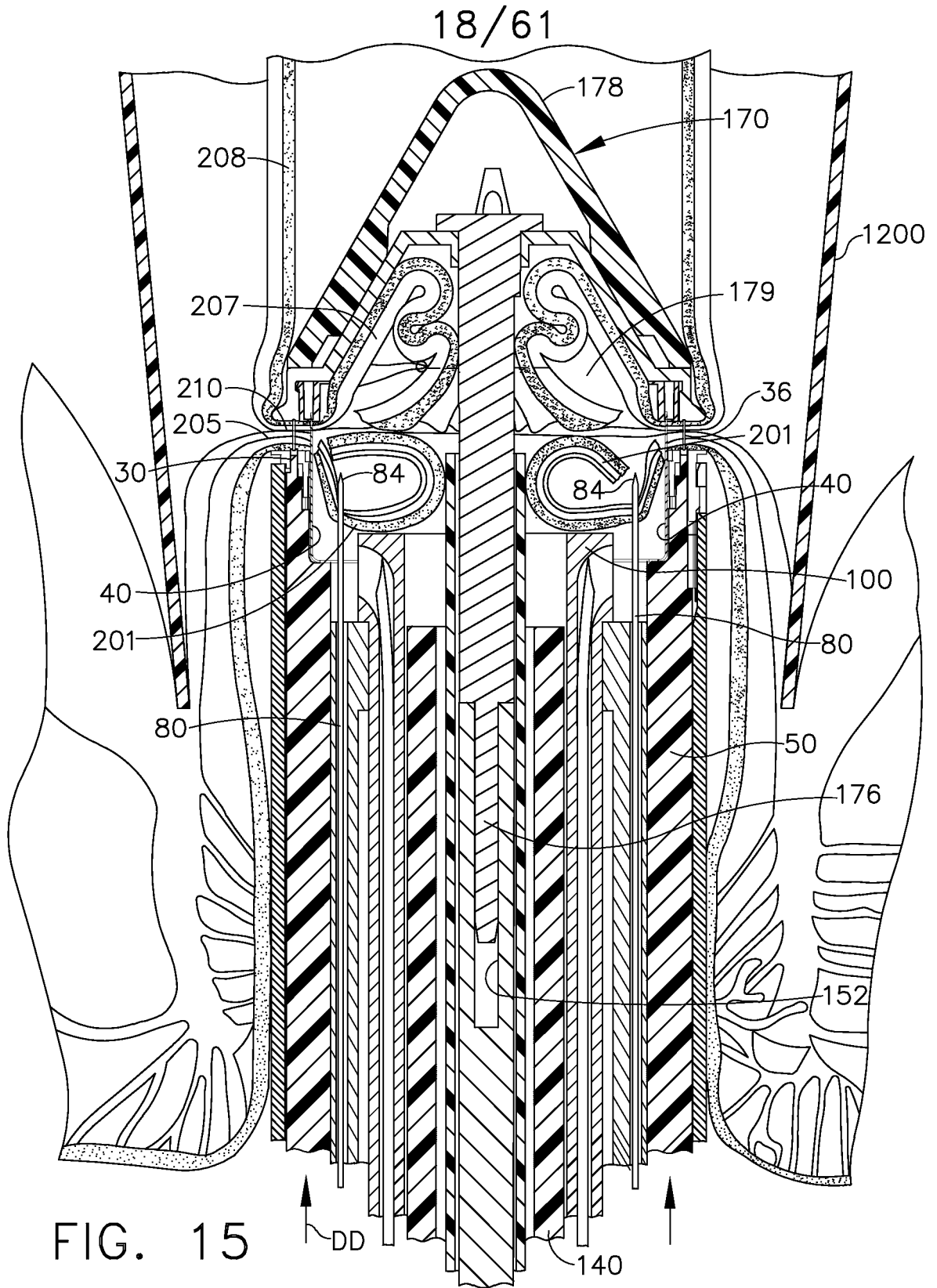
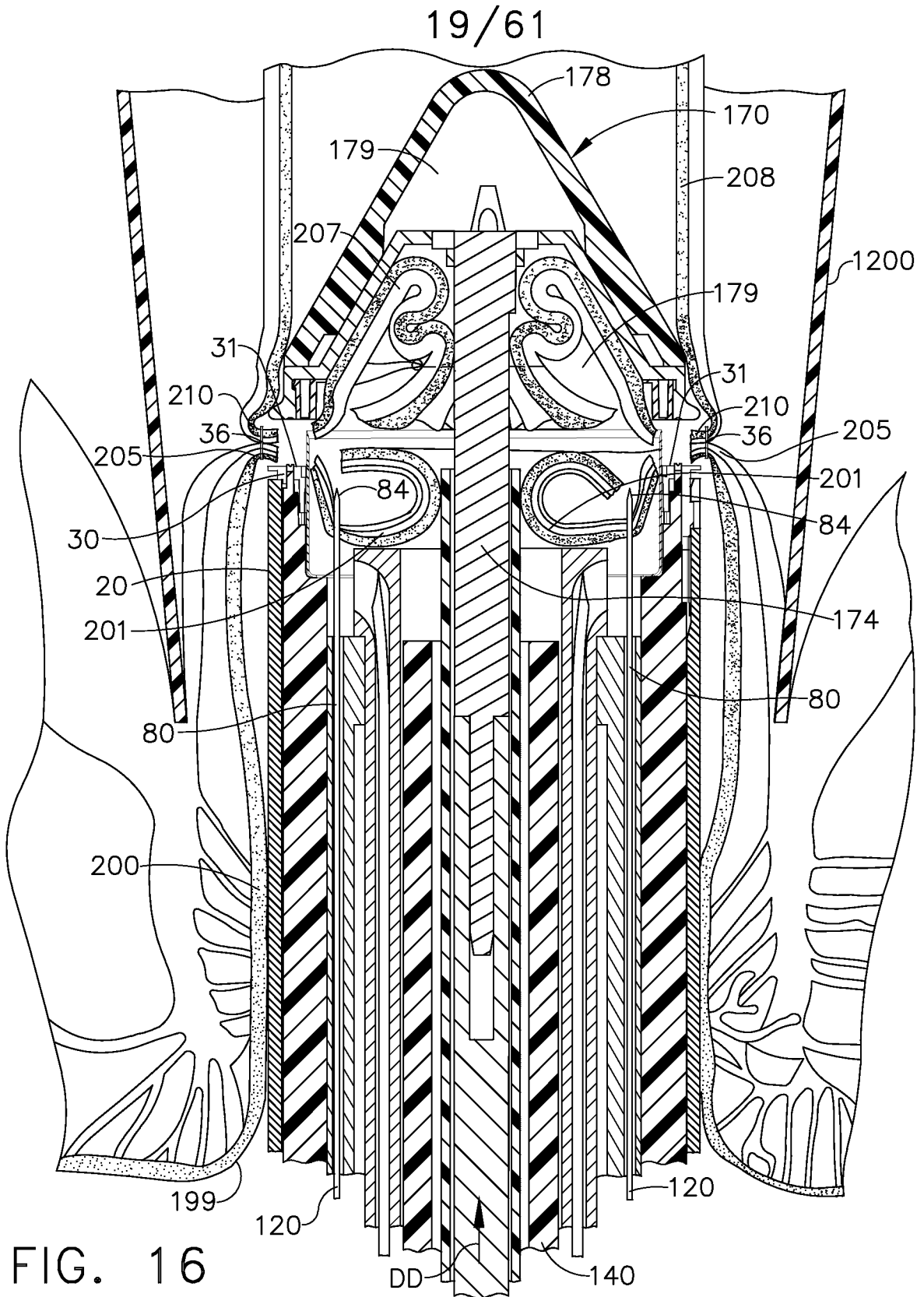
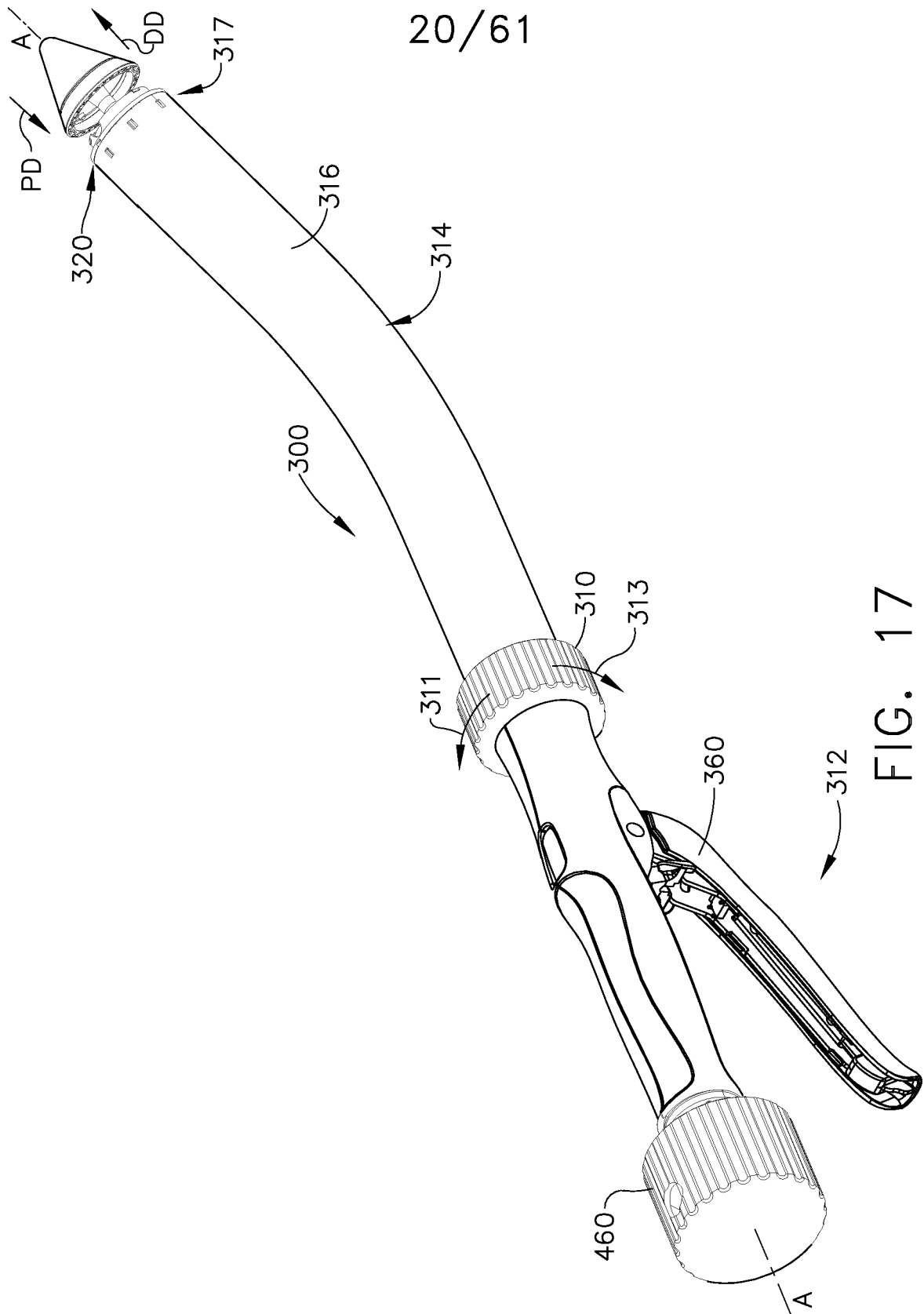

FIG. 14







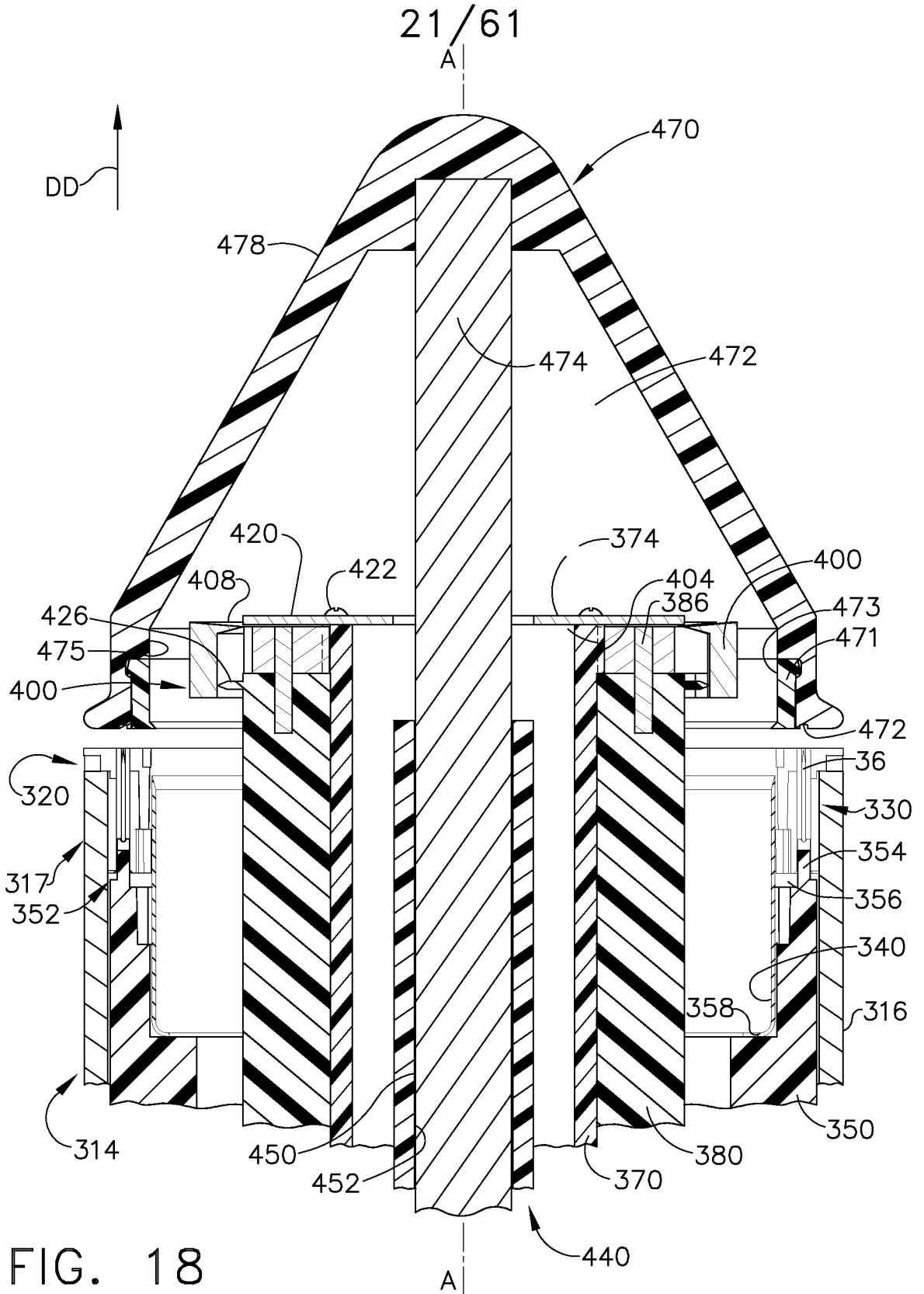

FIG. 18

22/61

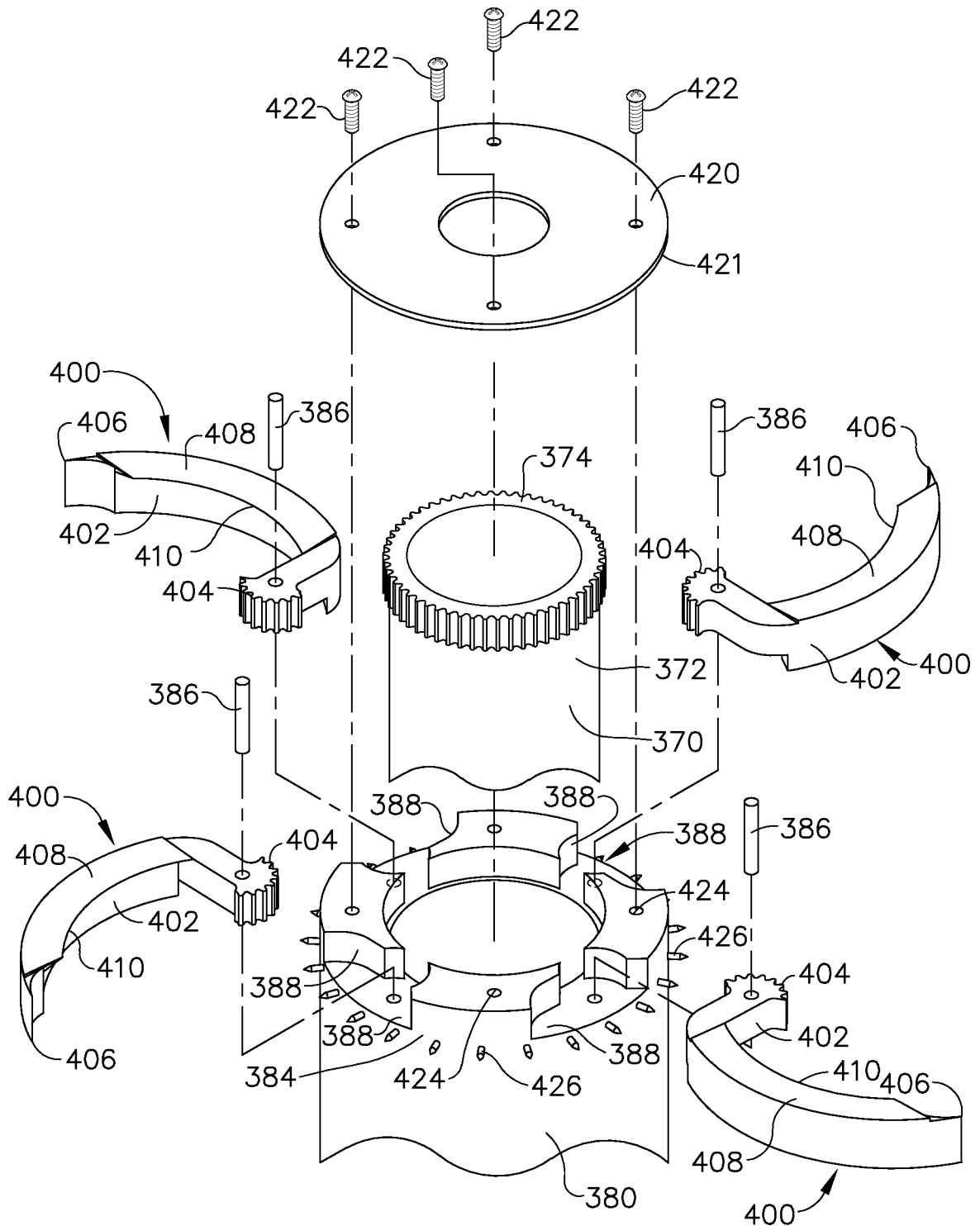

FIG. 19

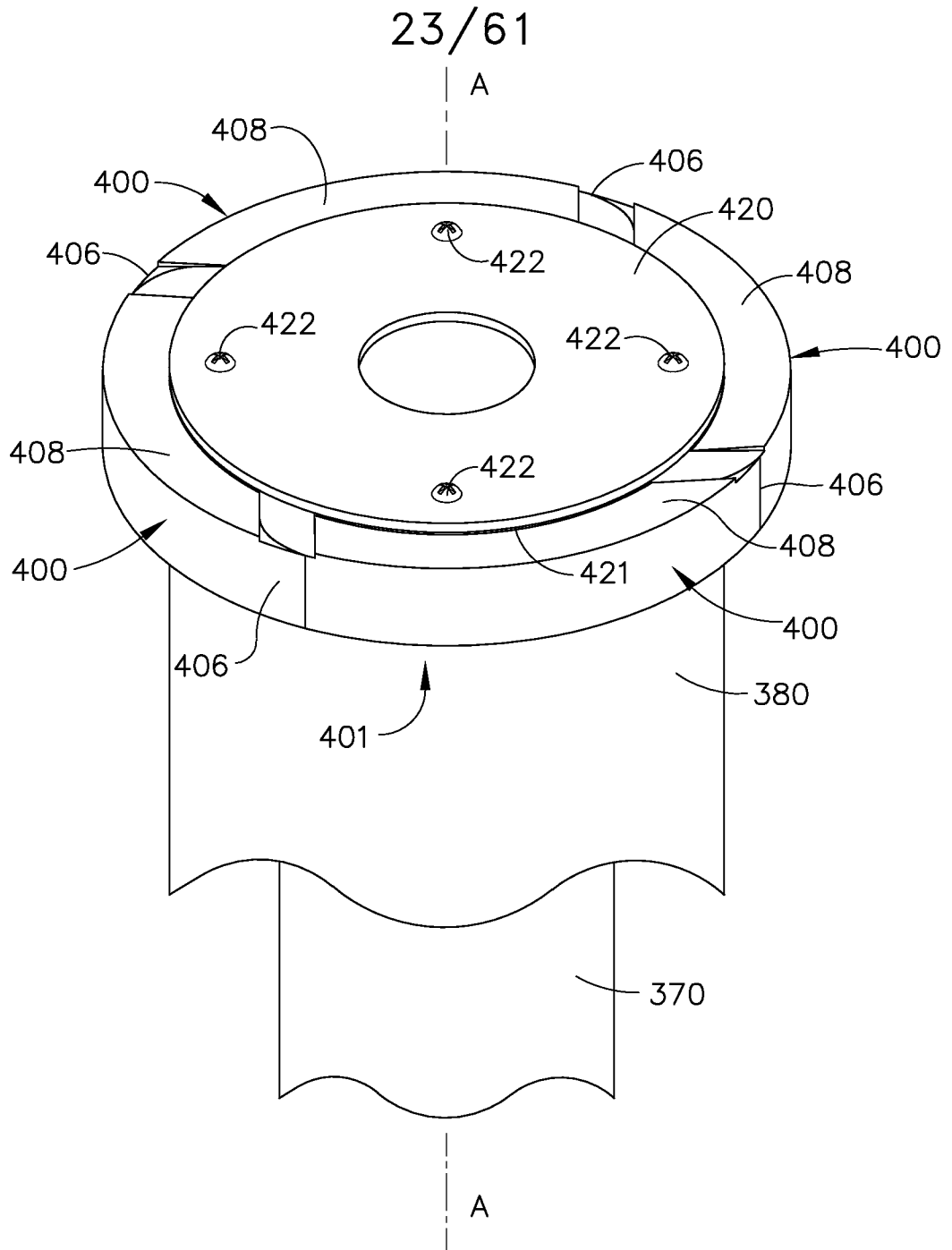

FIG. 20

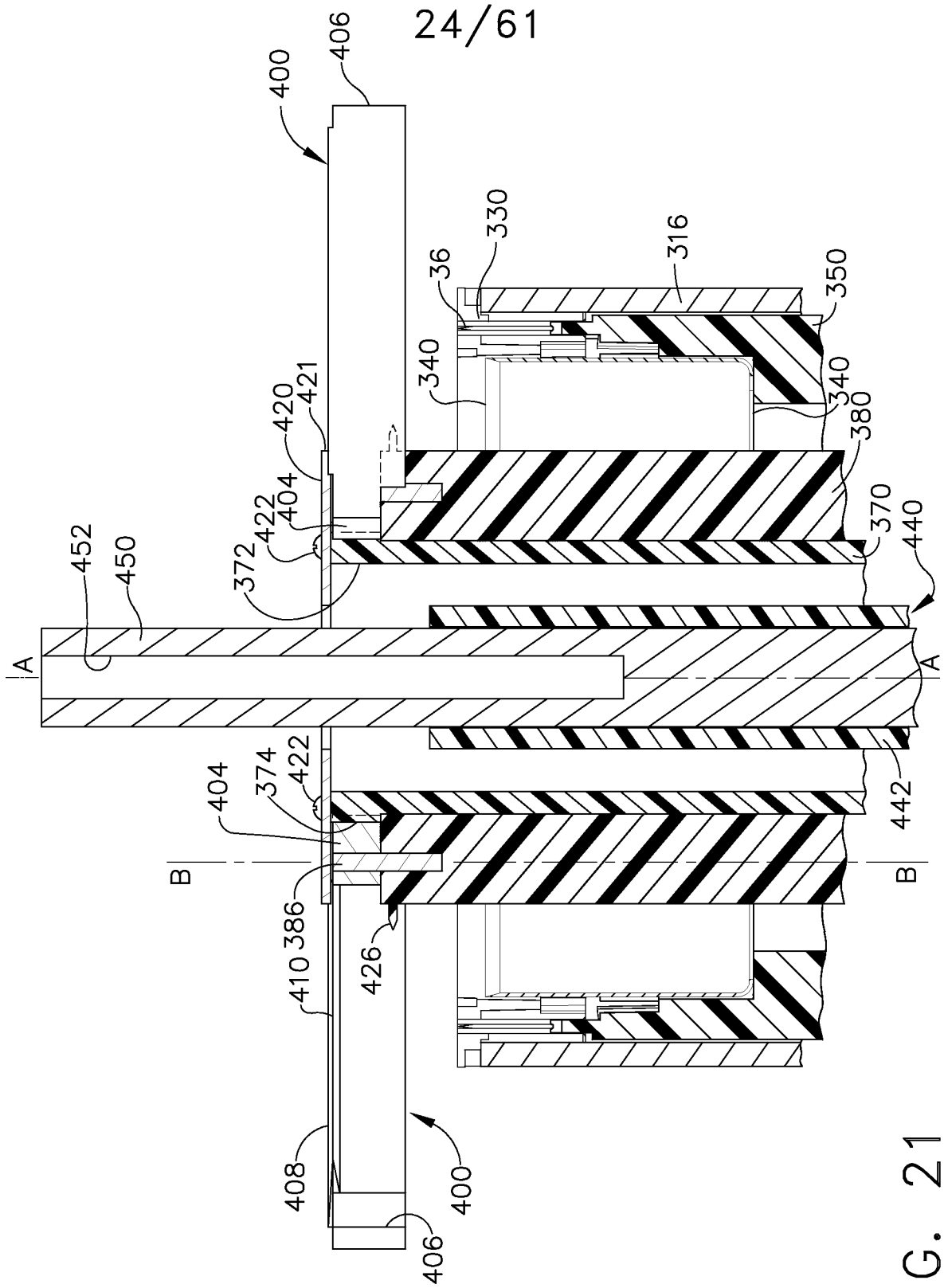

FIG. 21

25/61

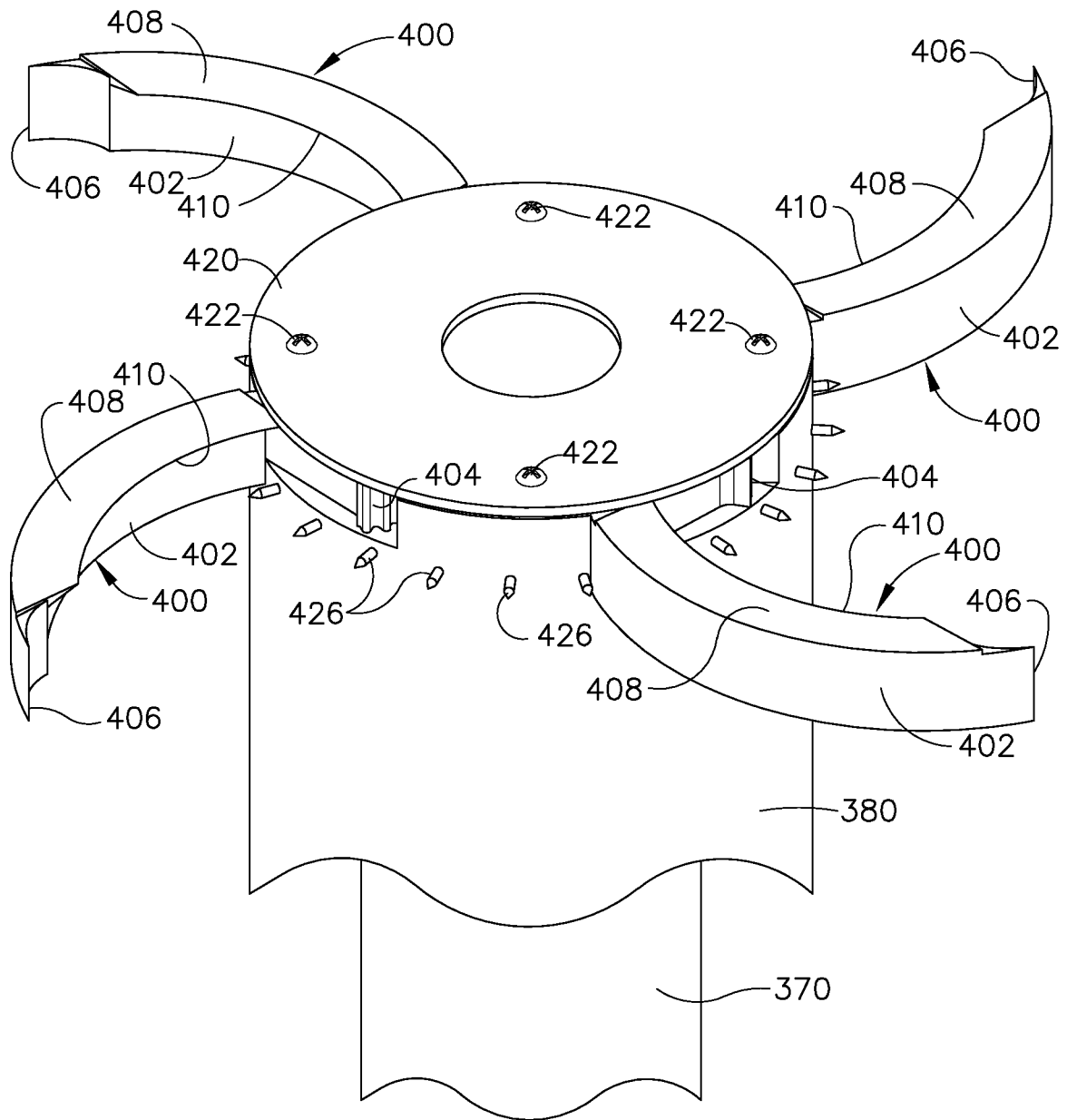
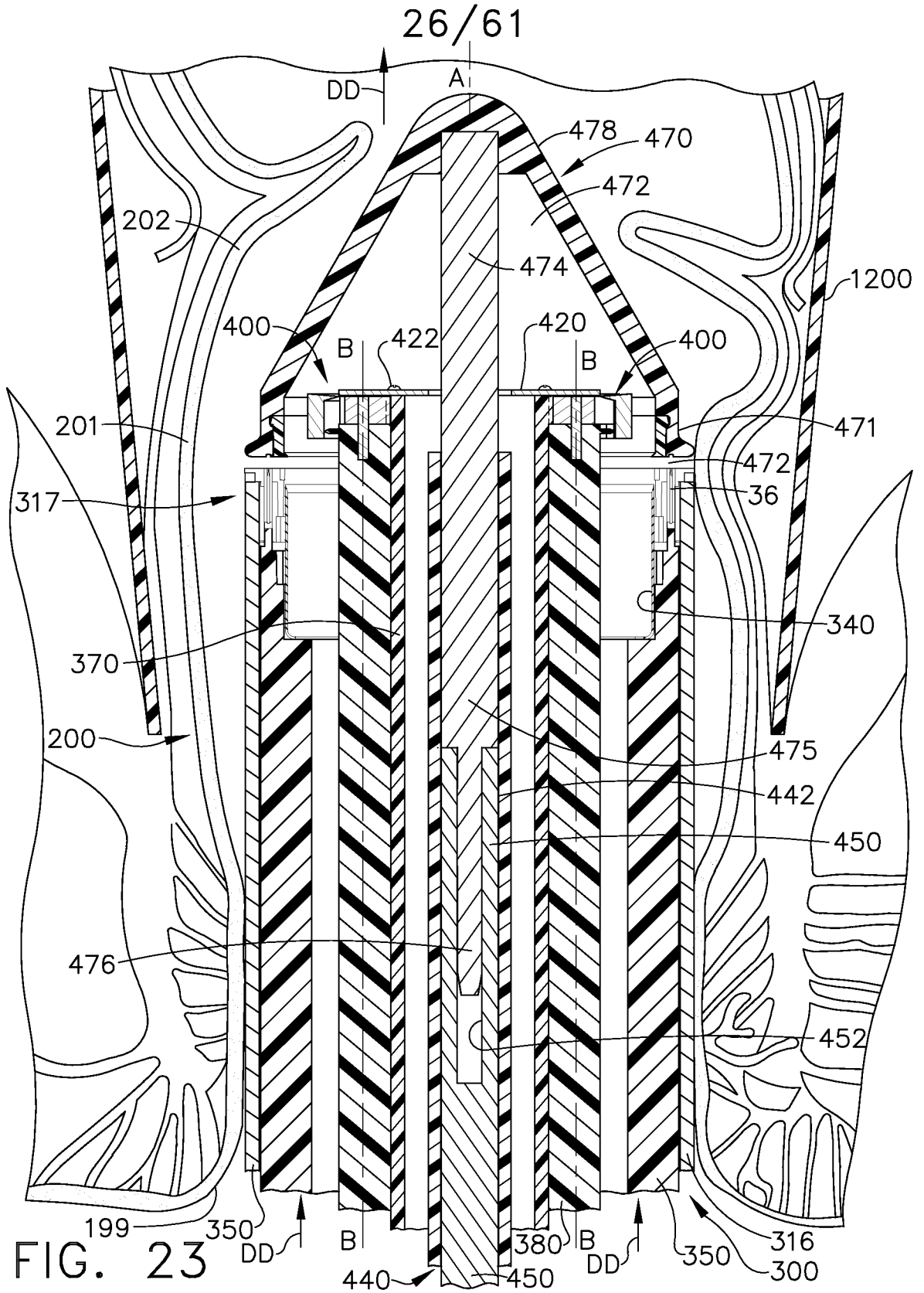
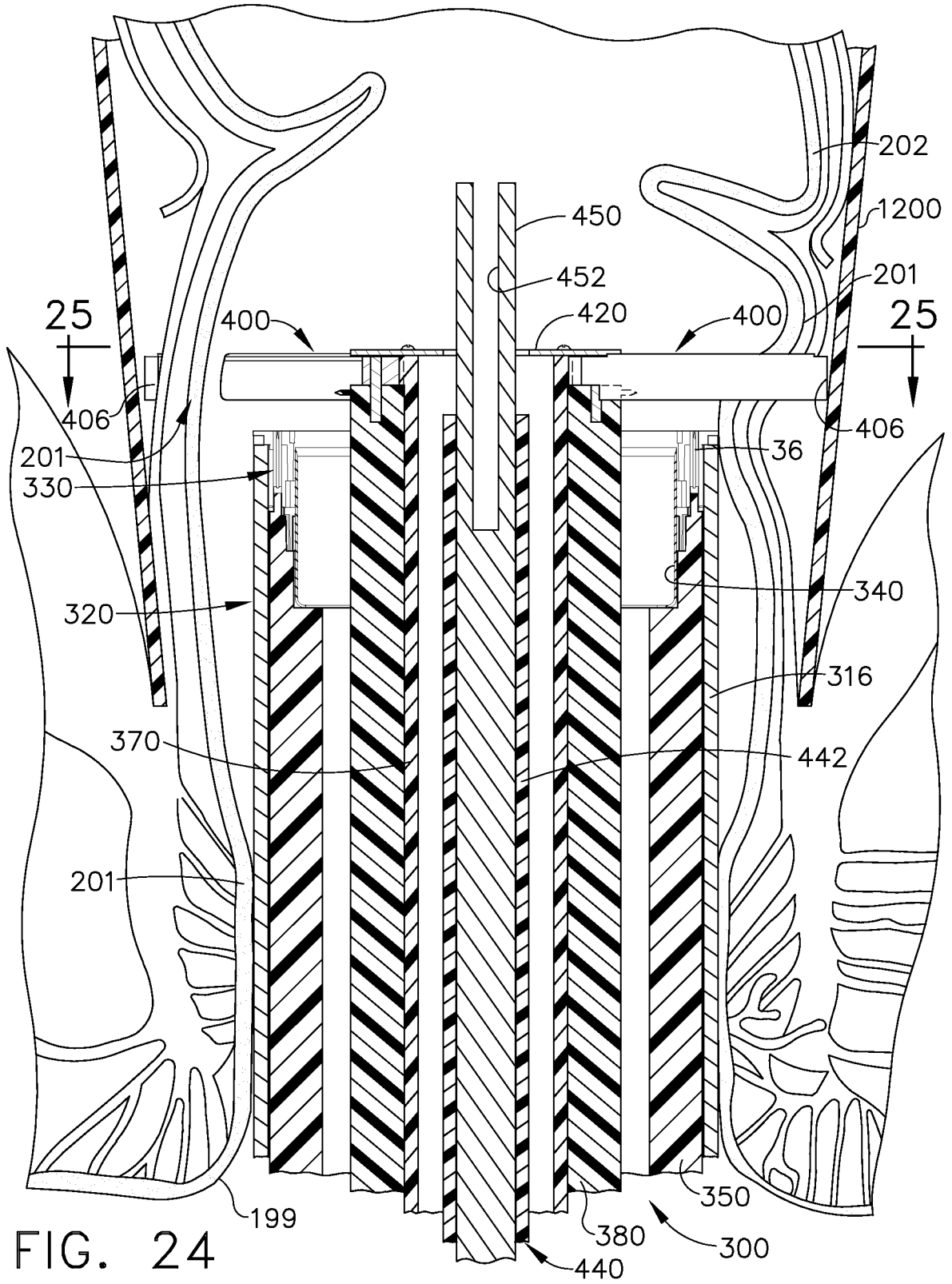

FIG. 22





28/61

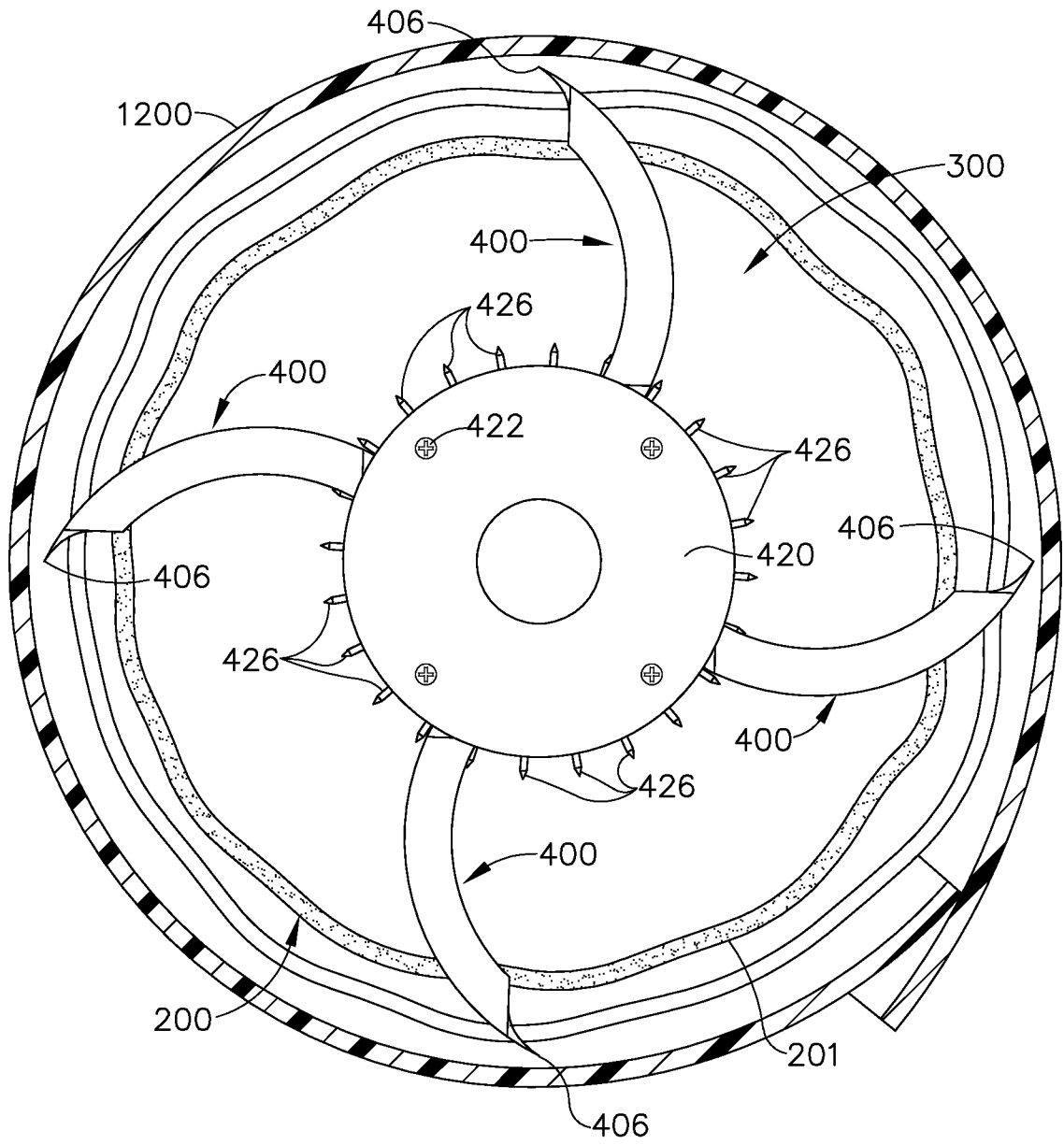

FIG. 25

29/61

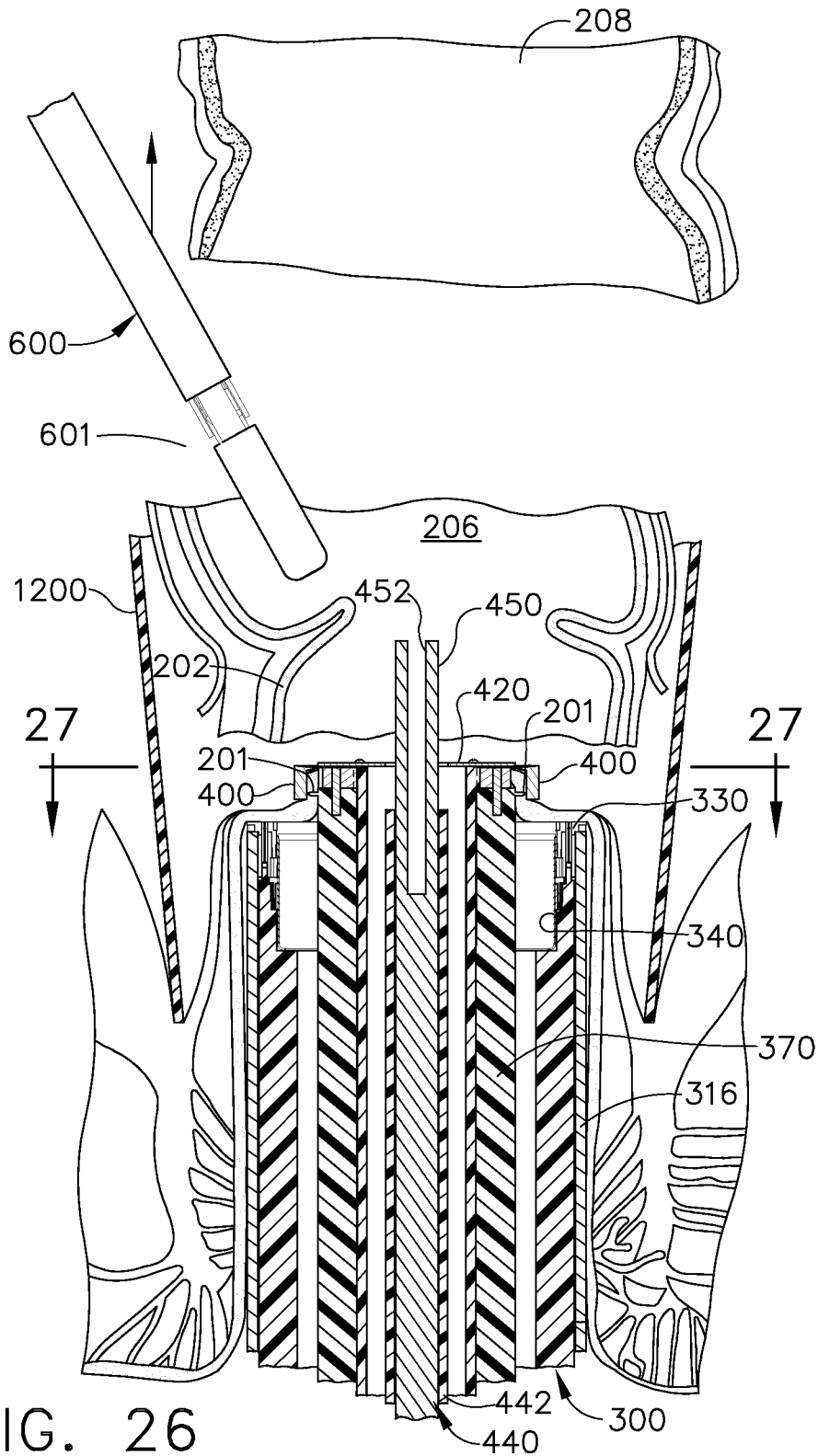

FIG. 26

30/61

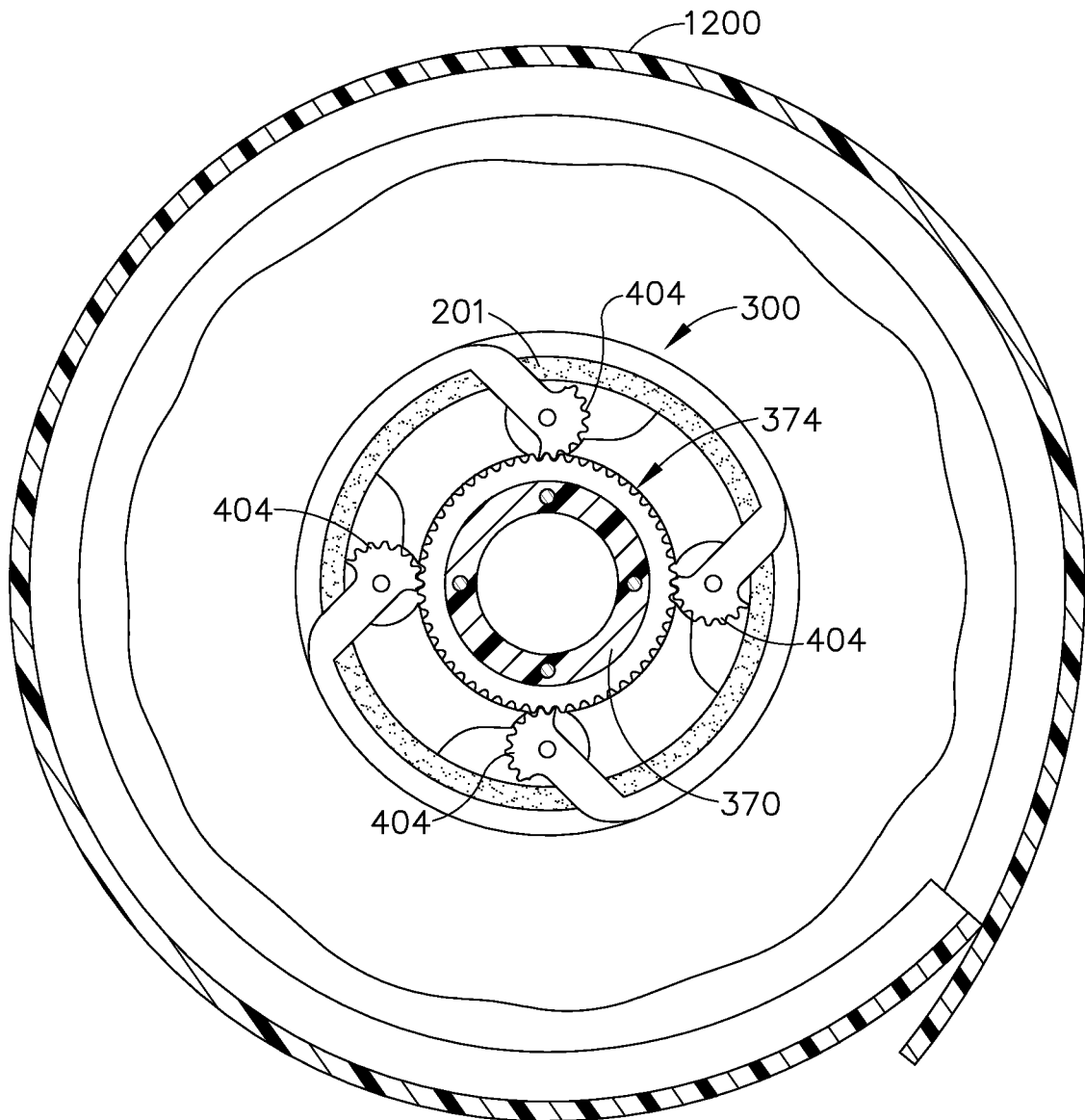
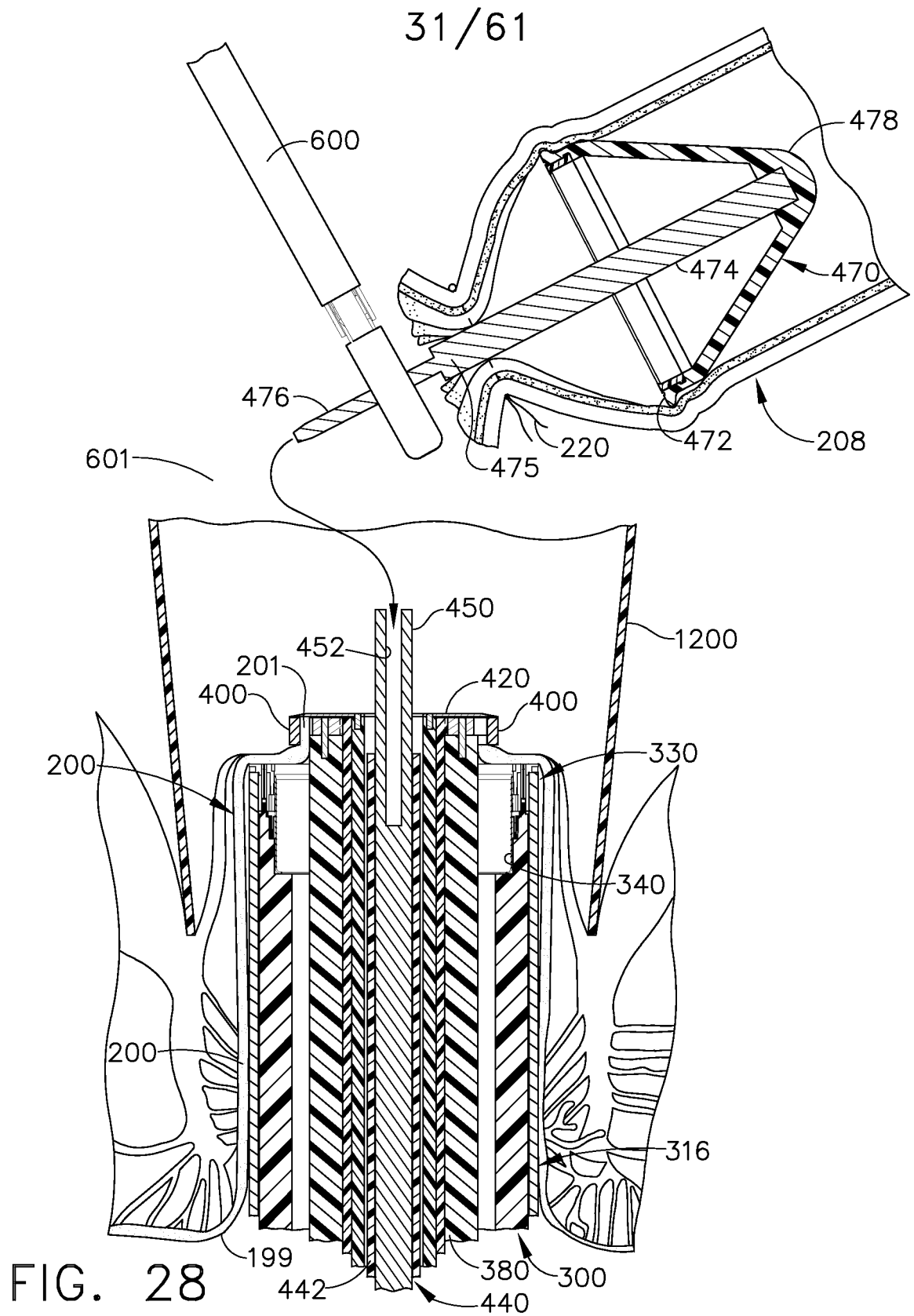

FIG. 27



34/61

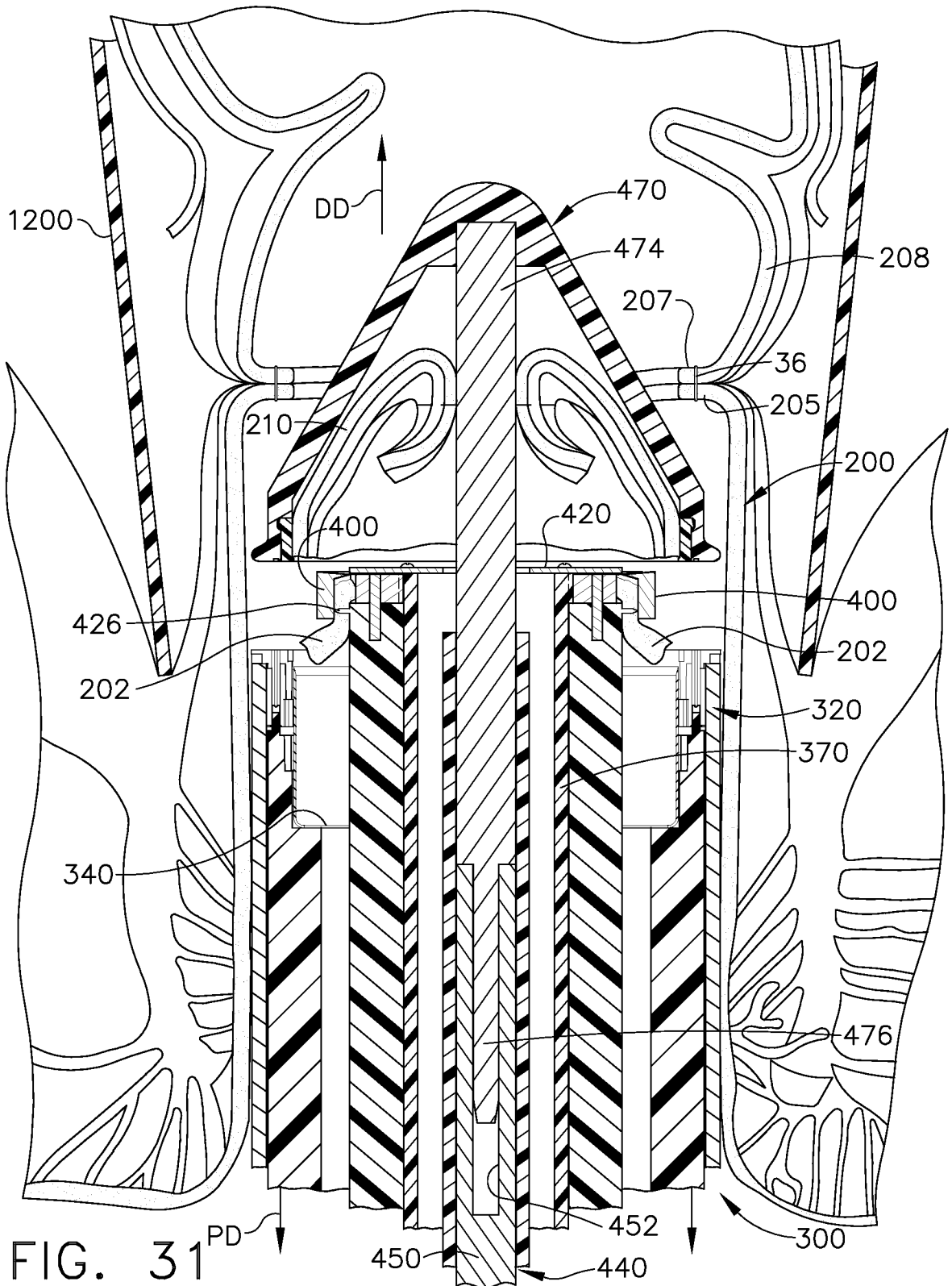
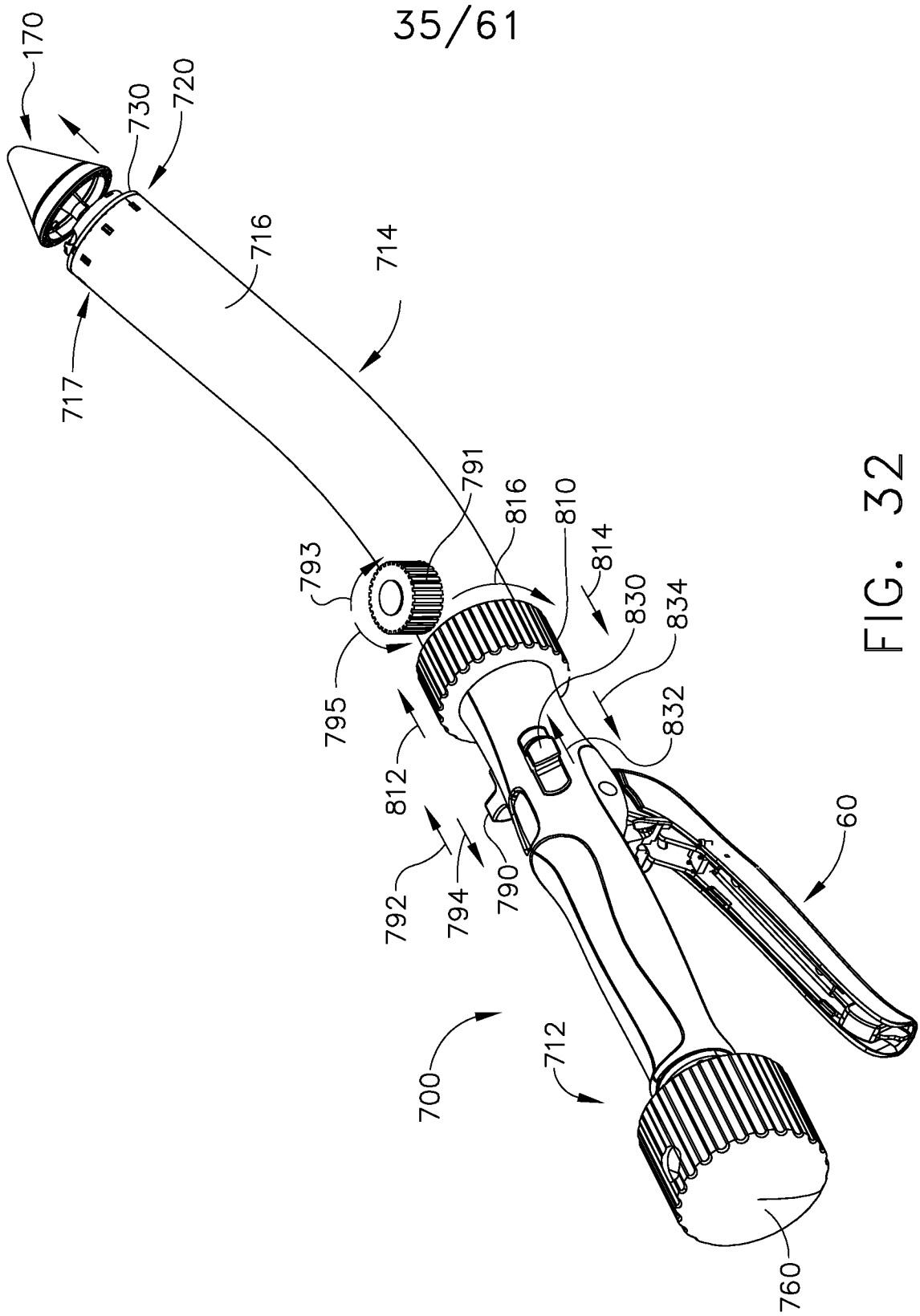

FIG. 31



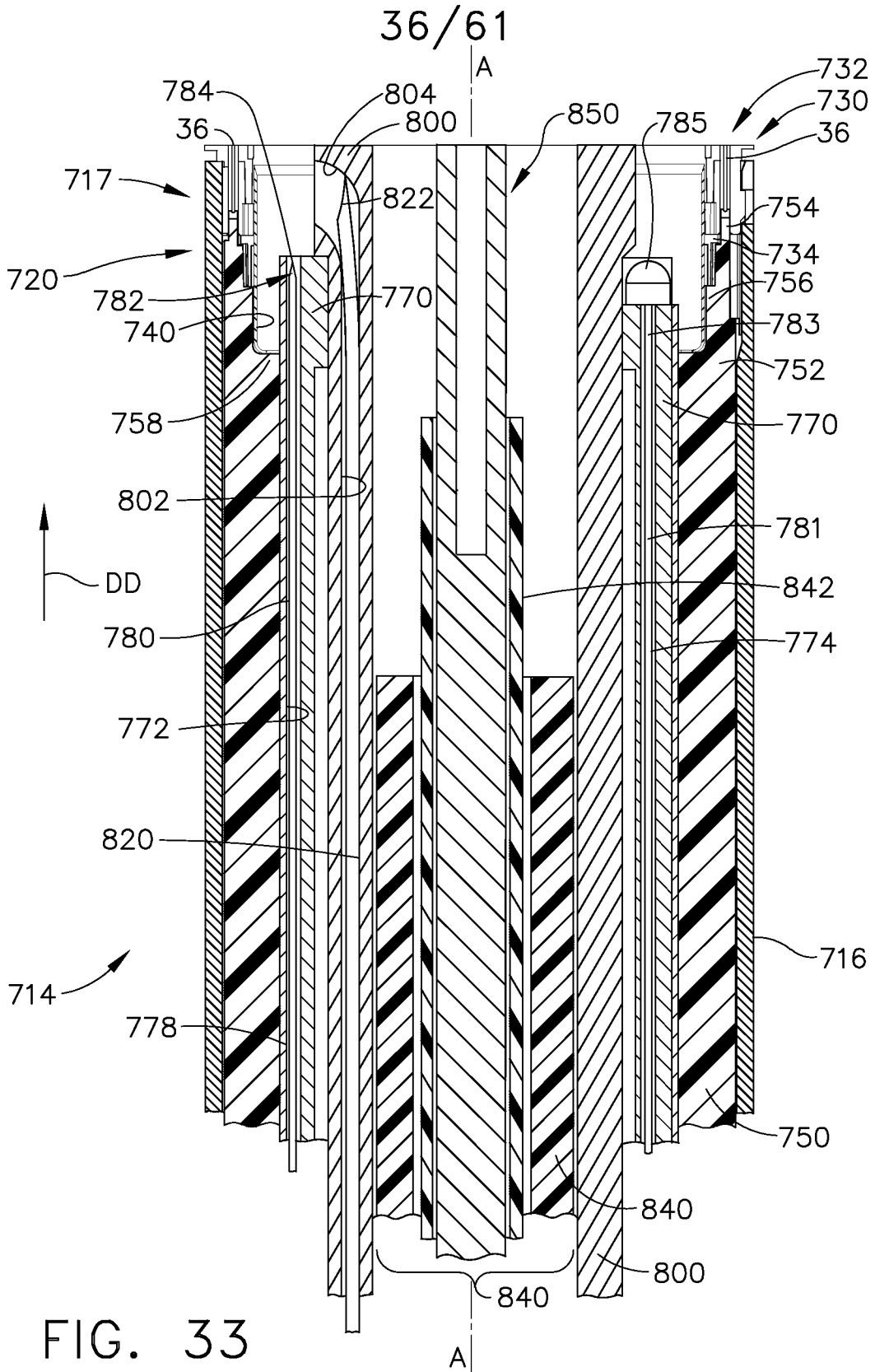
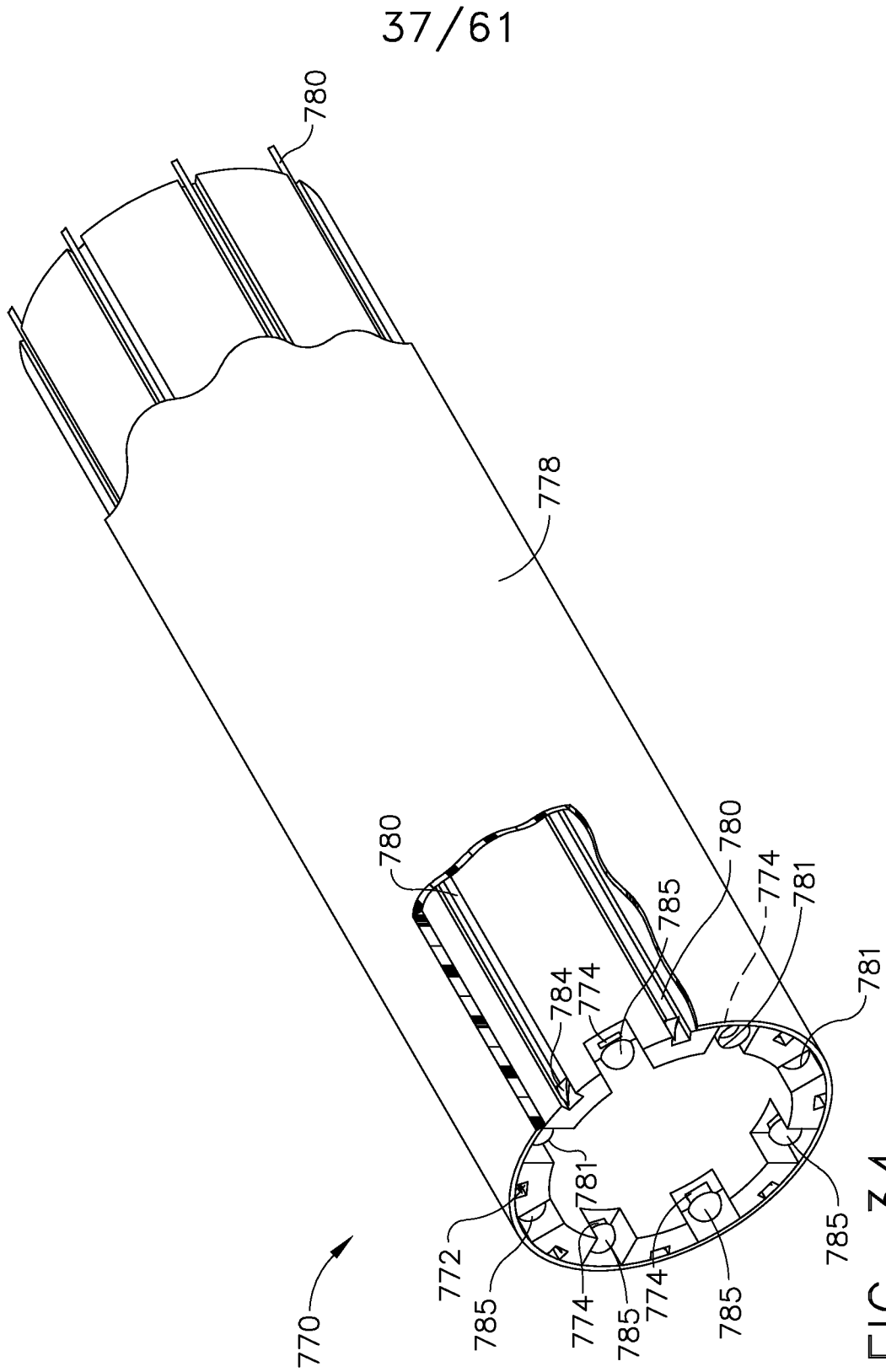
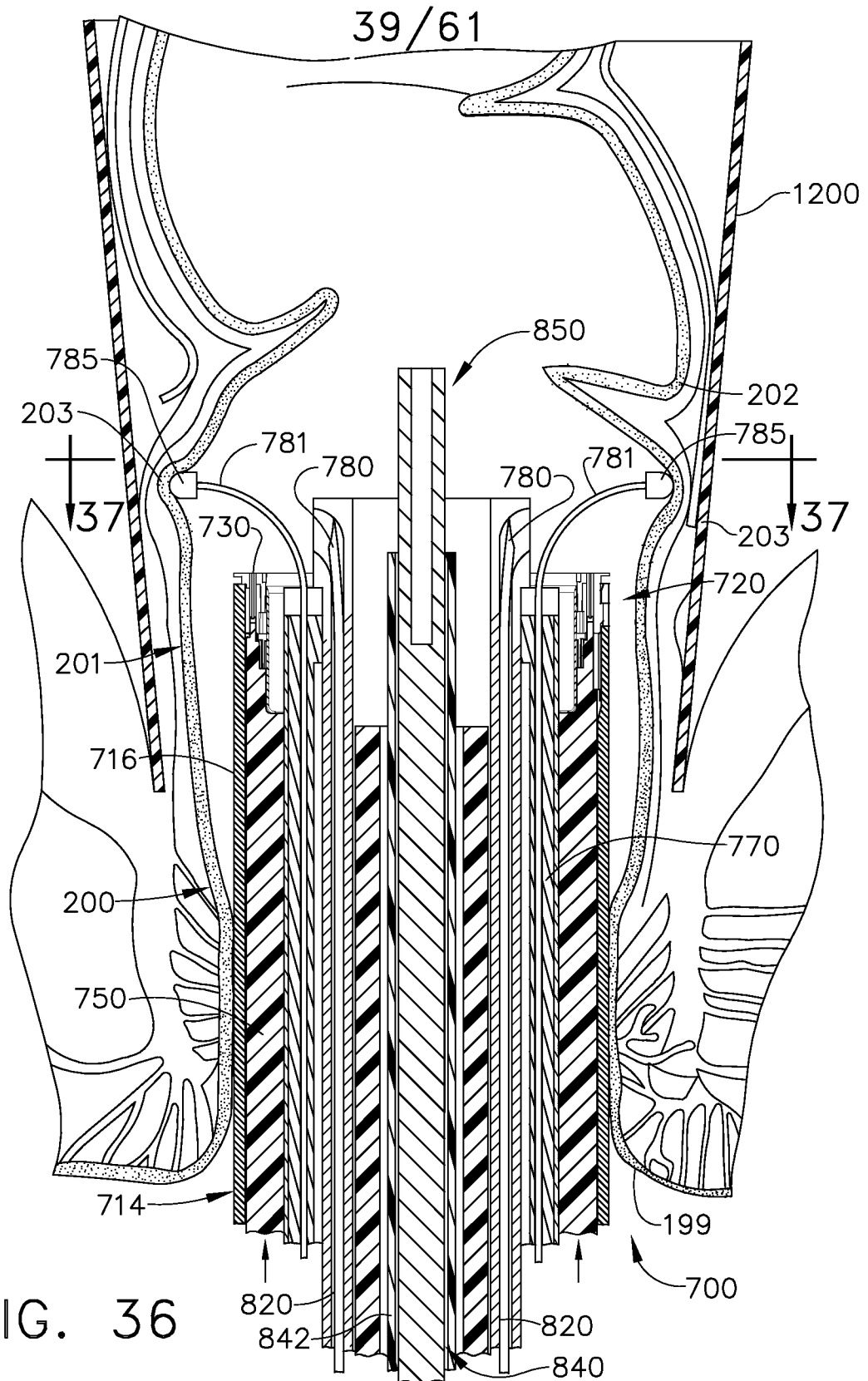

FIG. 33





40/61

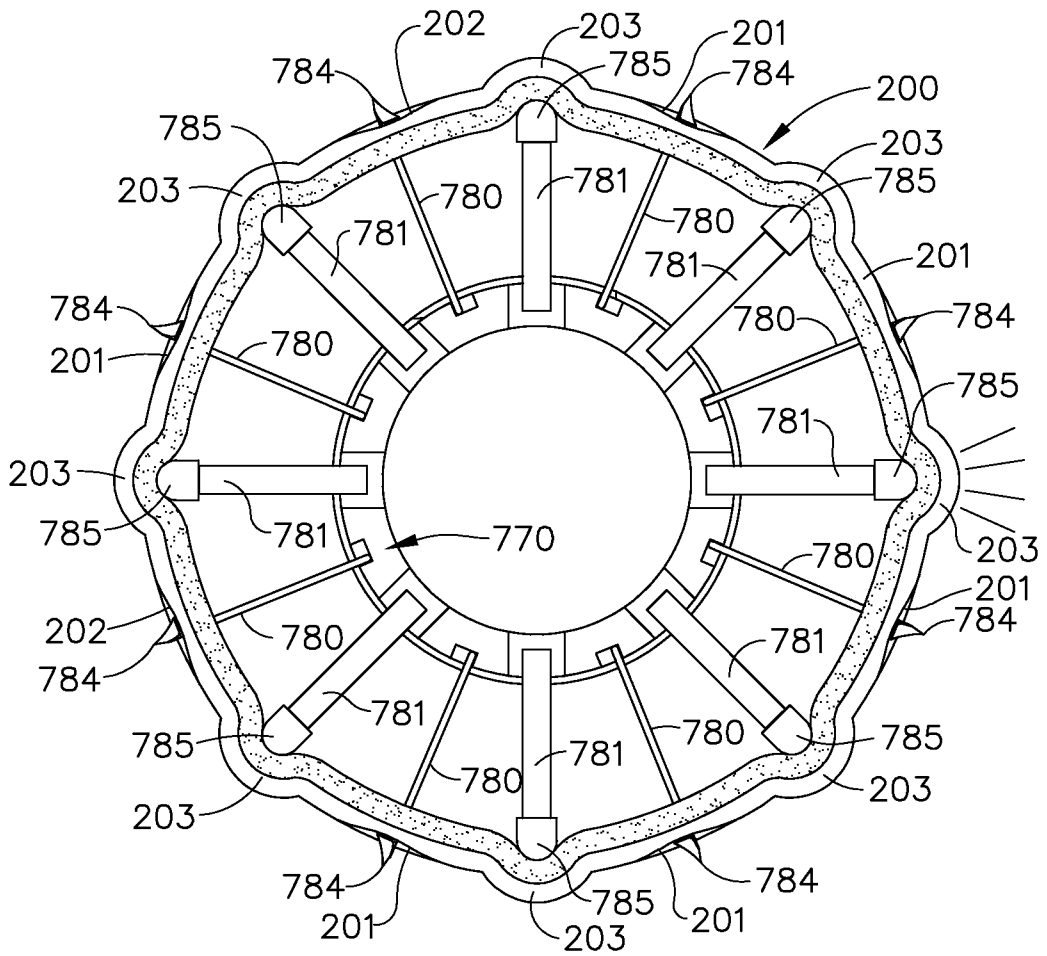
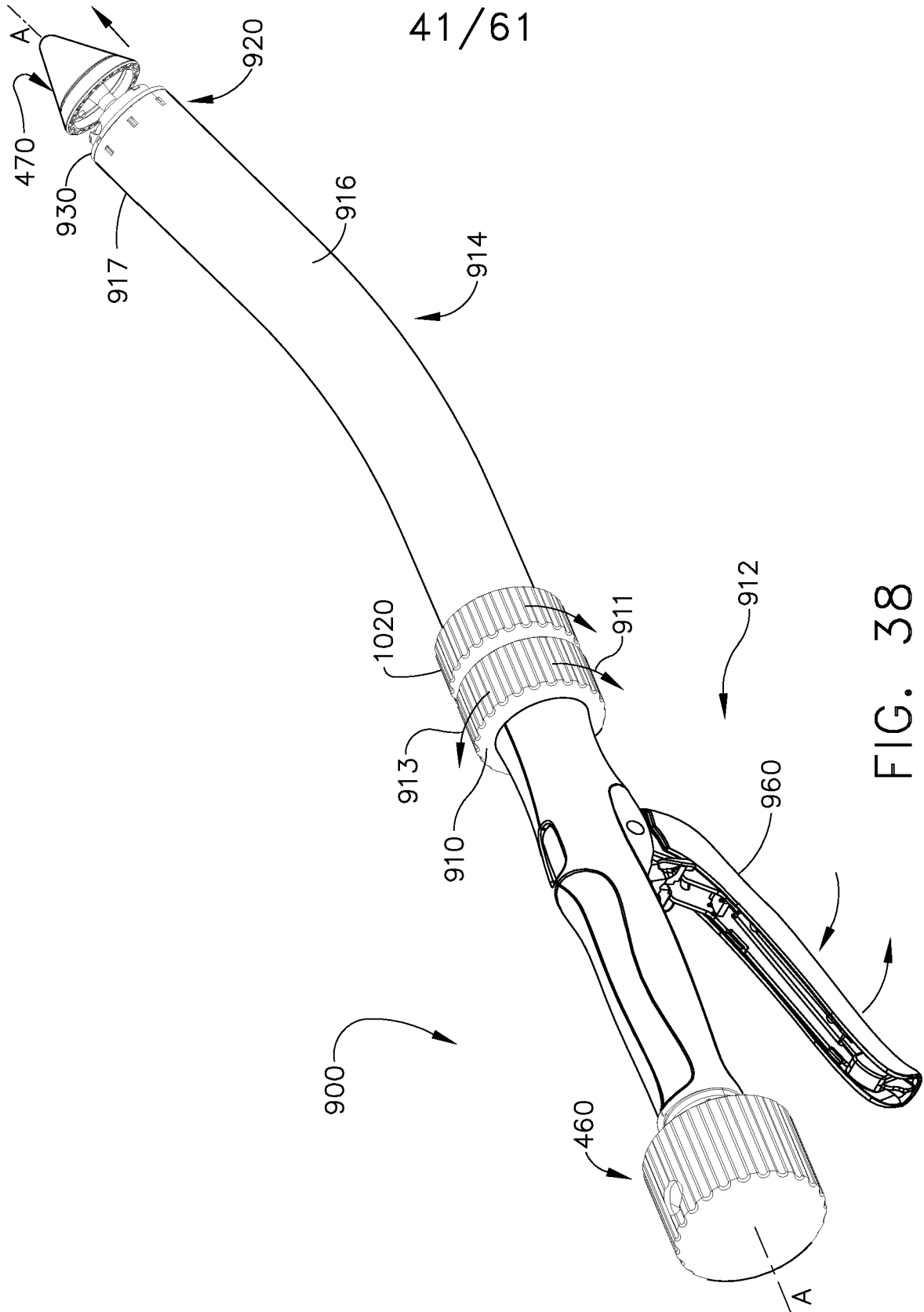
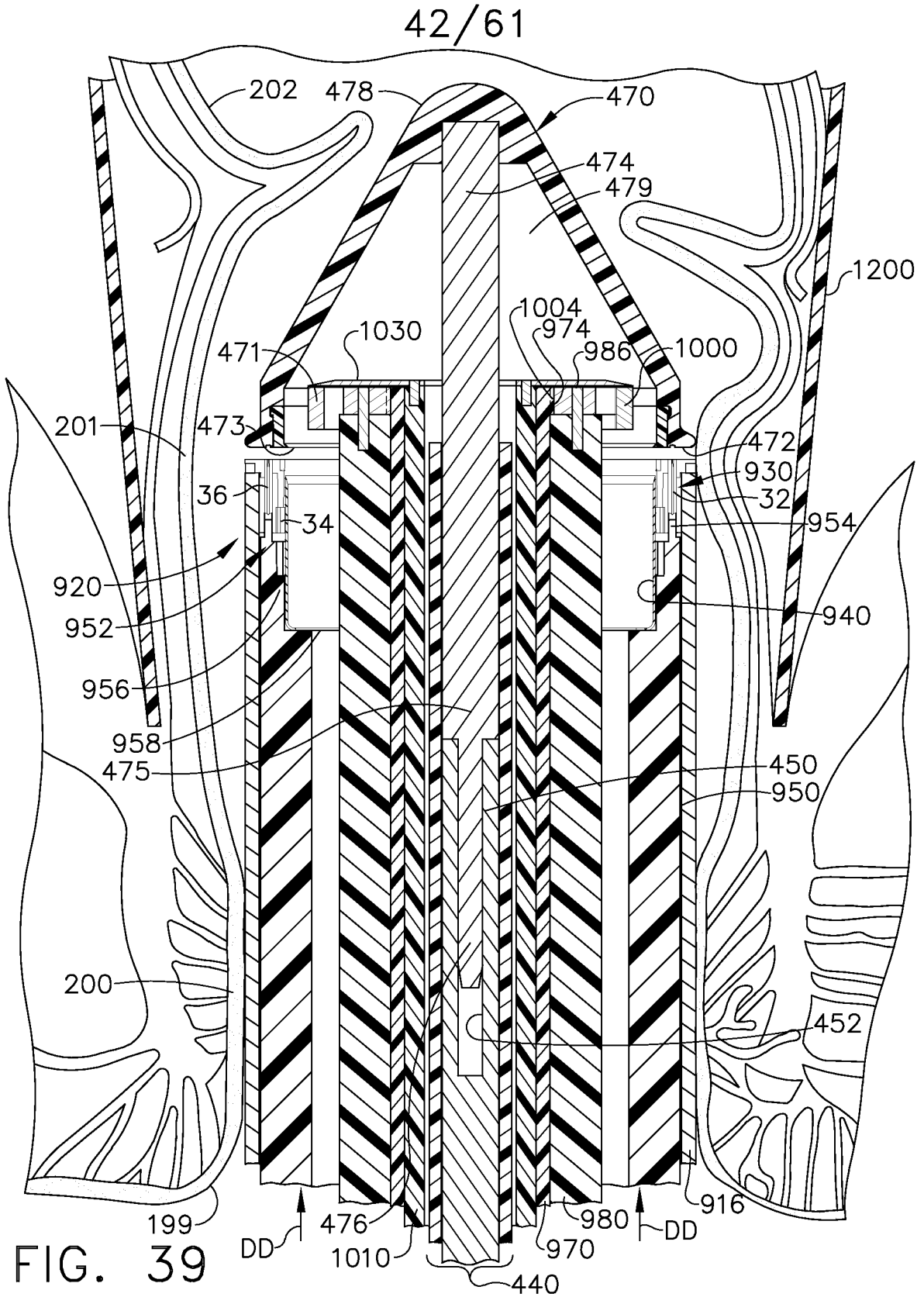

FIG. 37





43/61

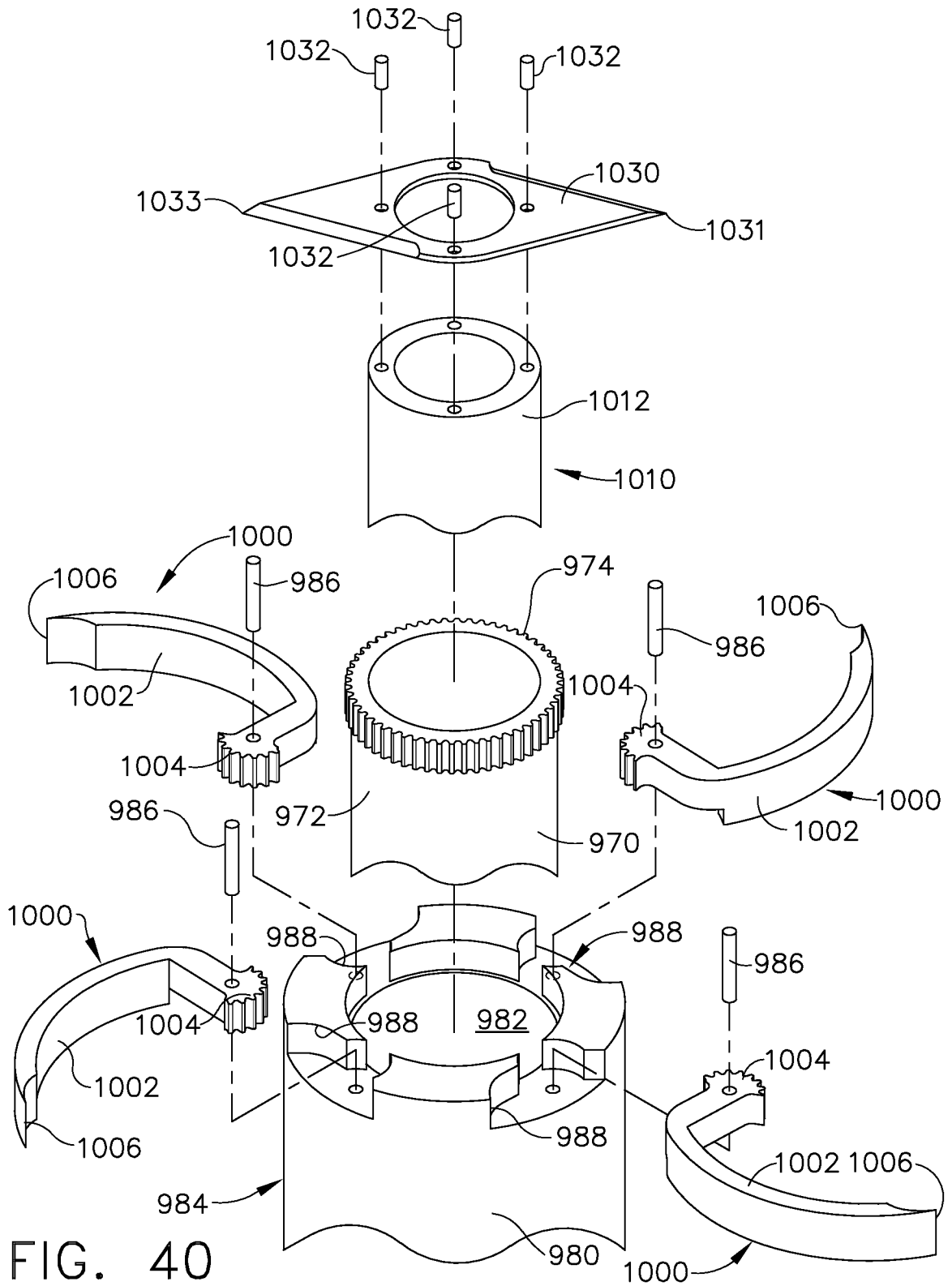

FIG. 40

44/61

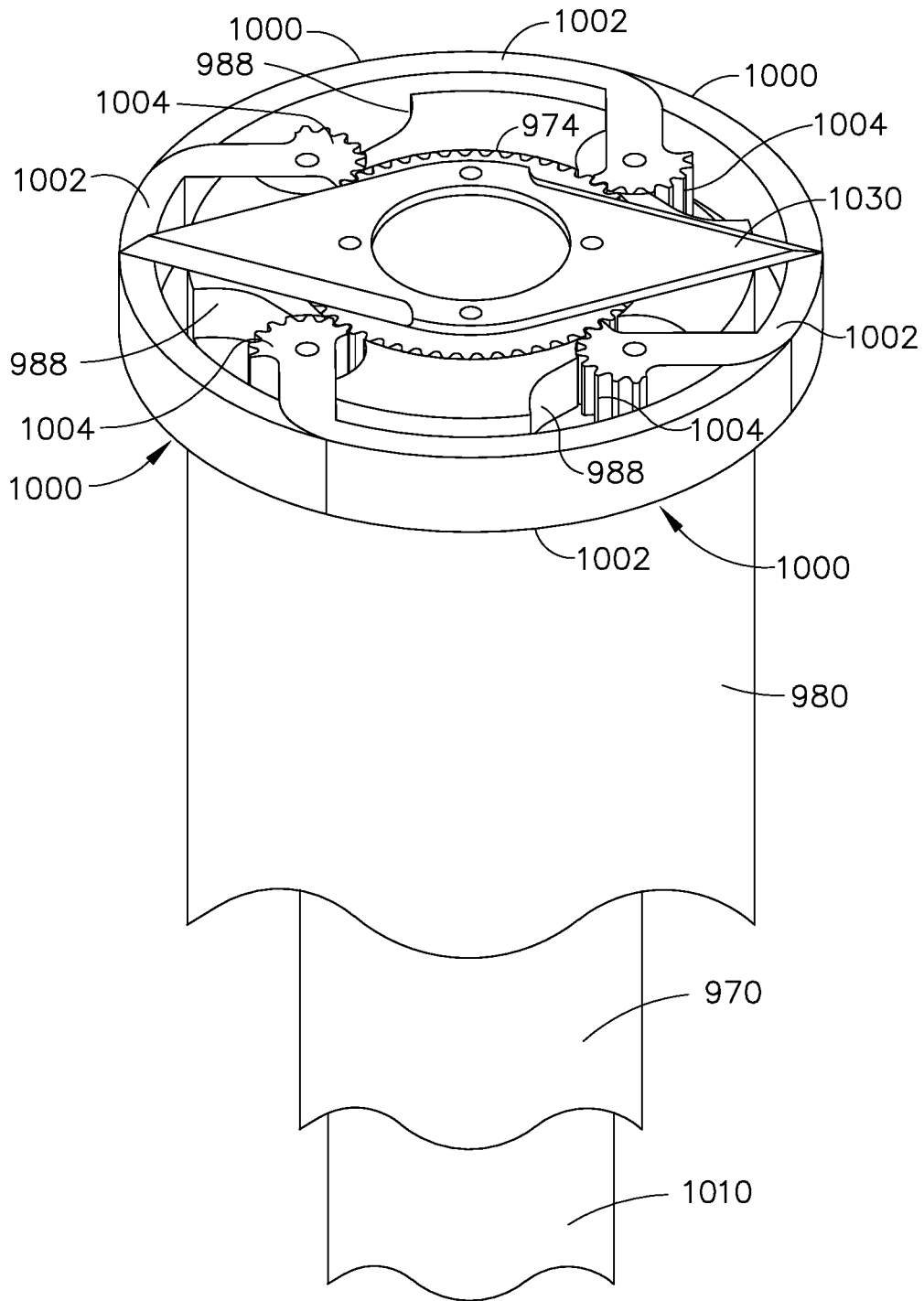

FIG. 41

45/61

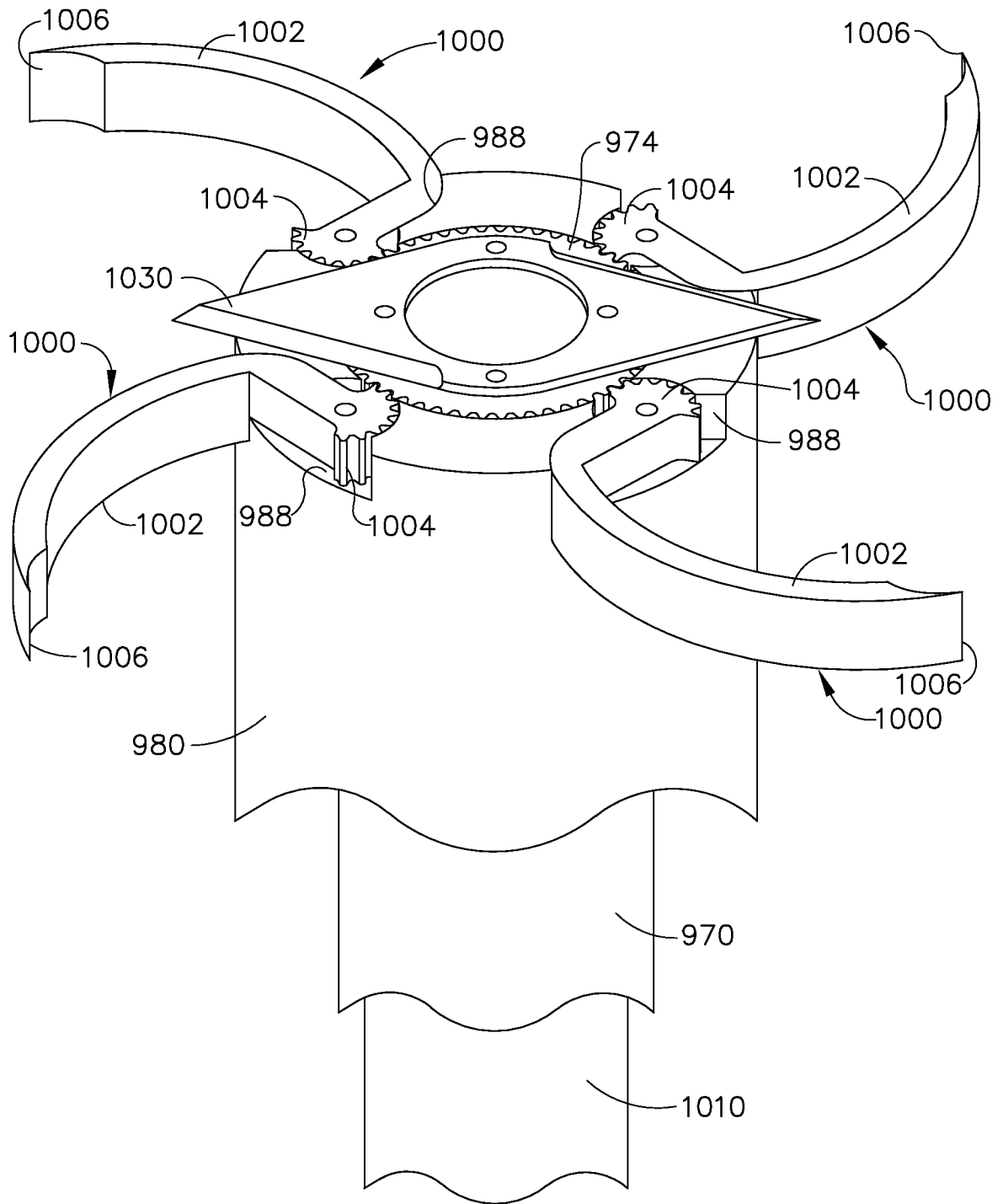

FIG. 42

46/61

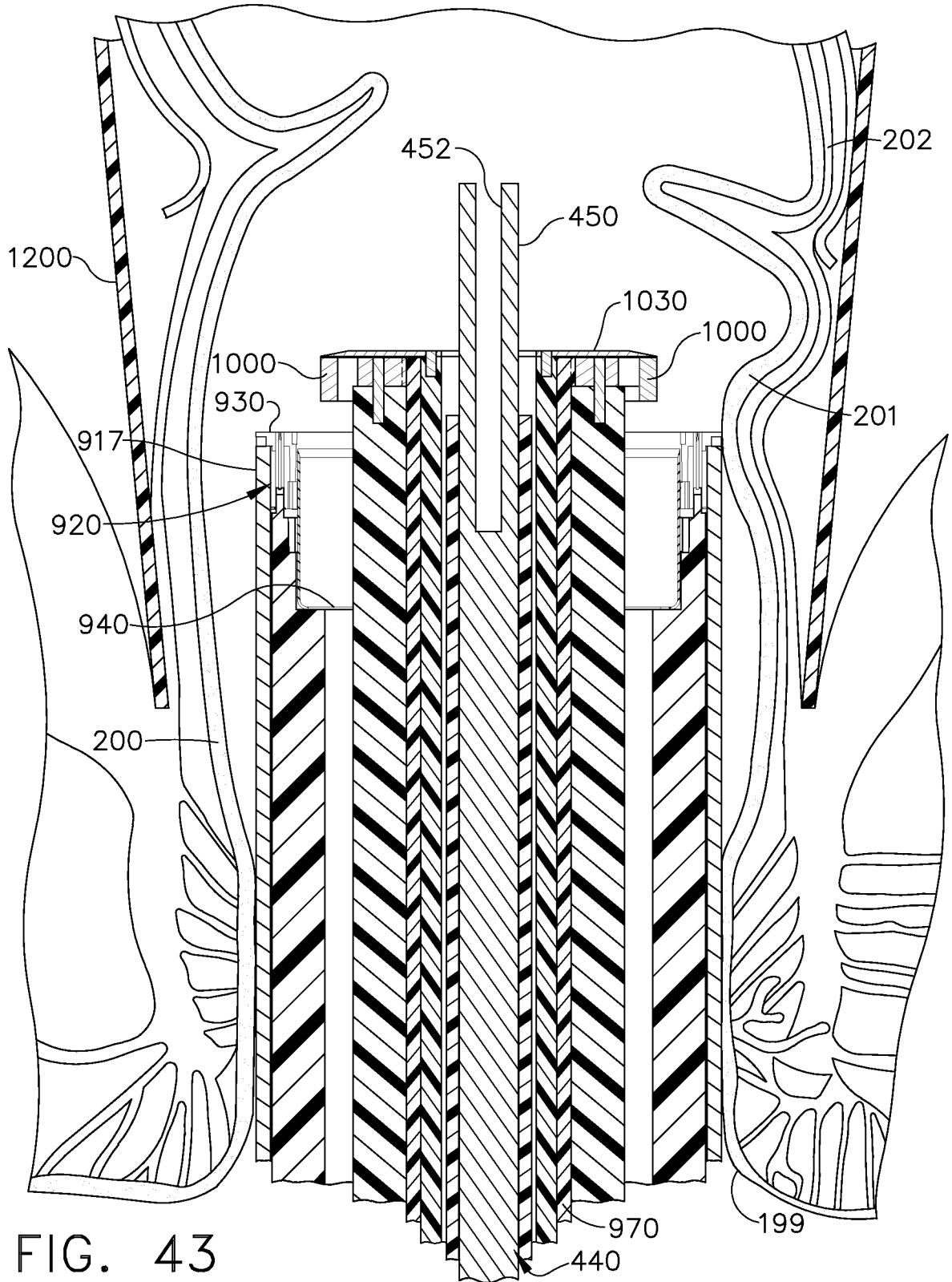

FIG. 43

47/61

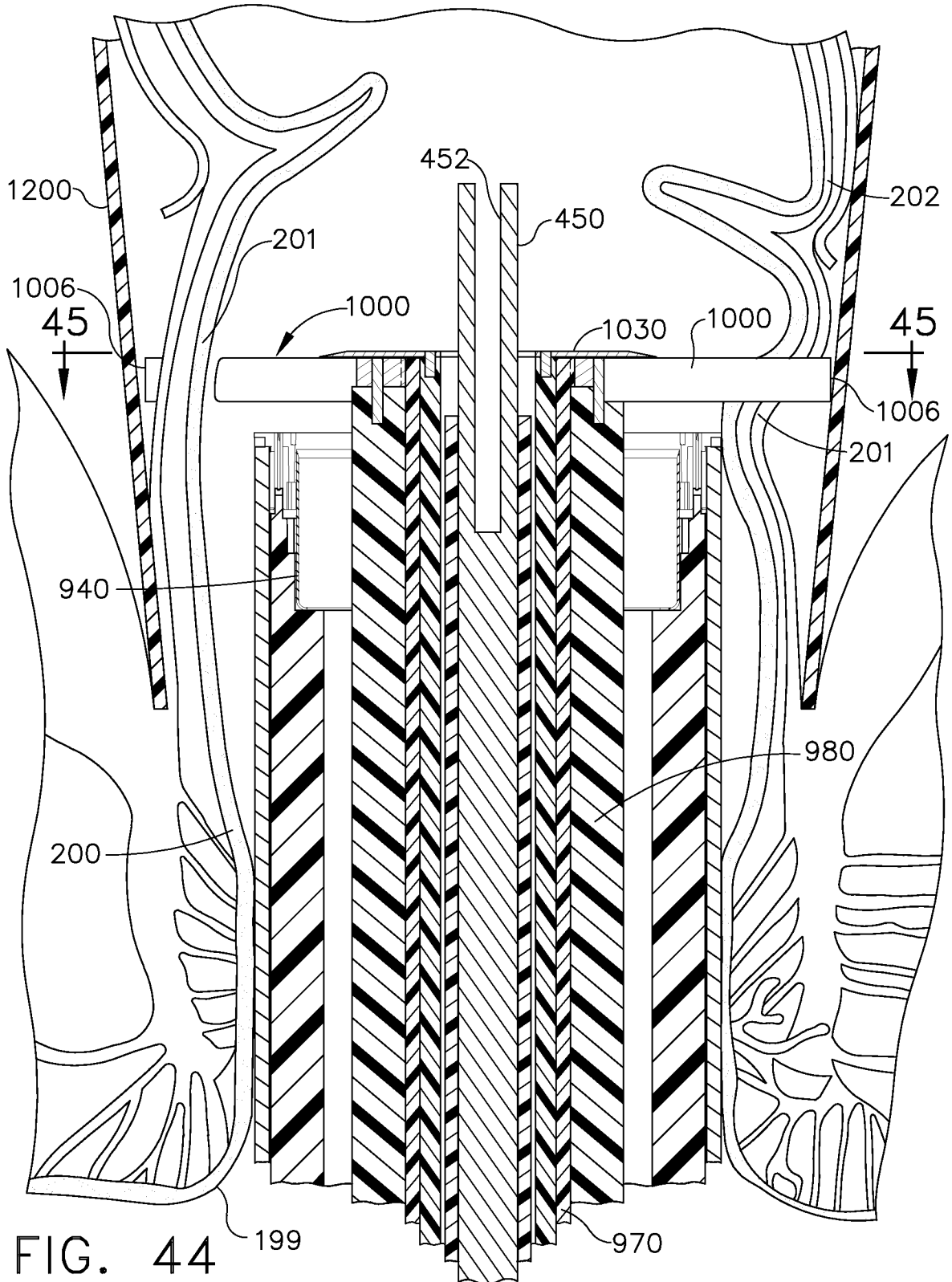

FIG. 44

48/61

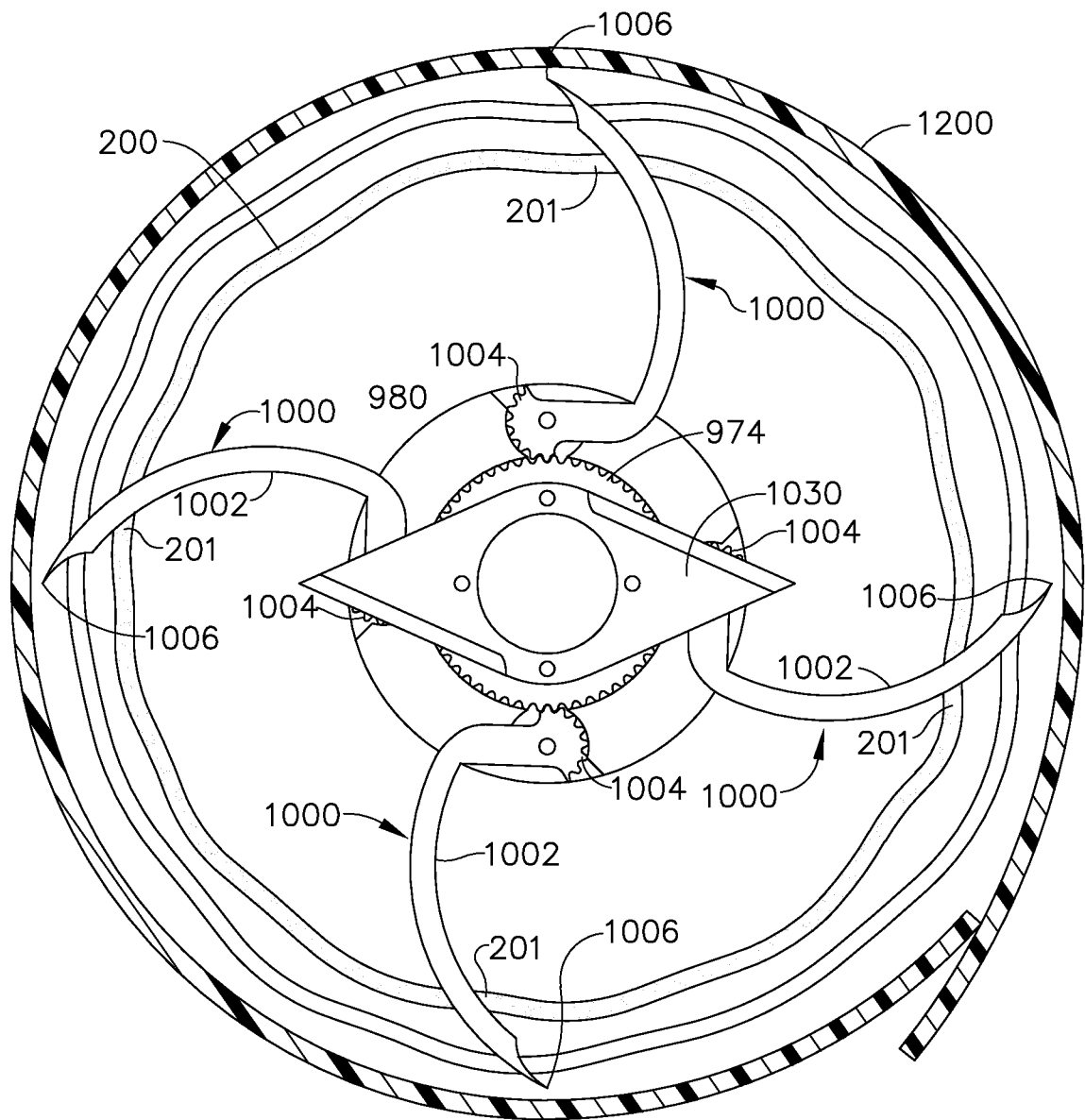

FIG. 45

49/61

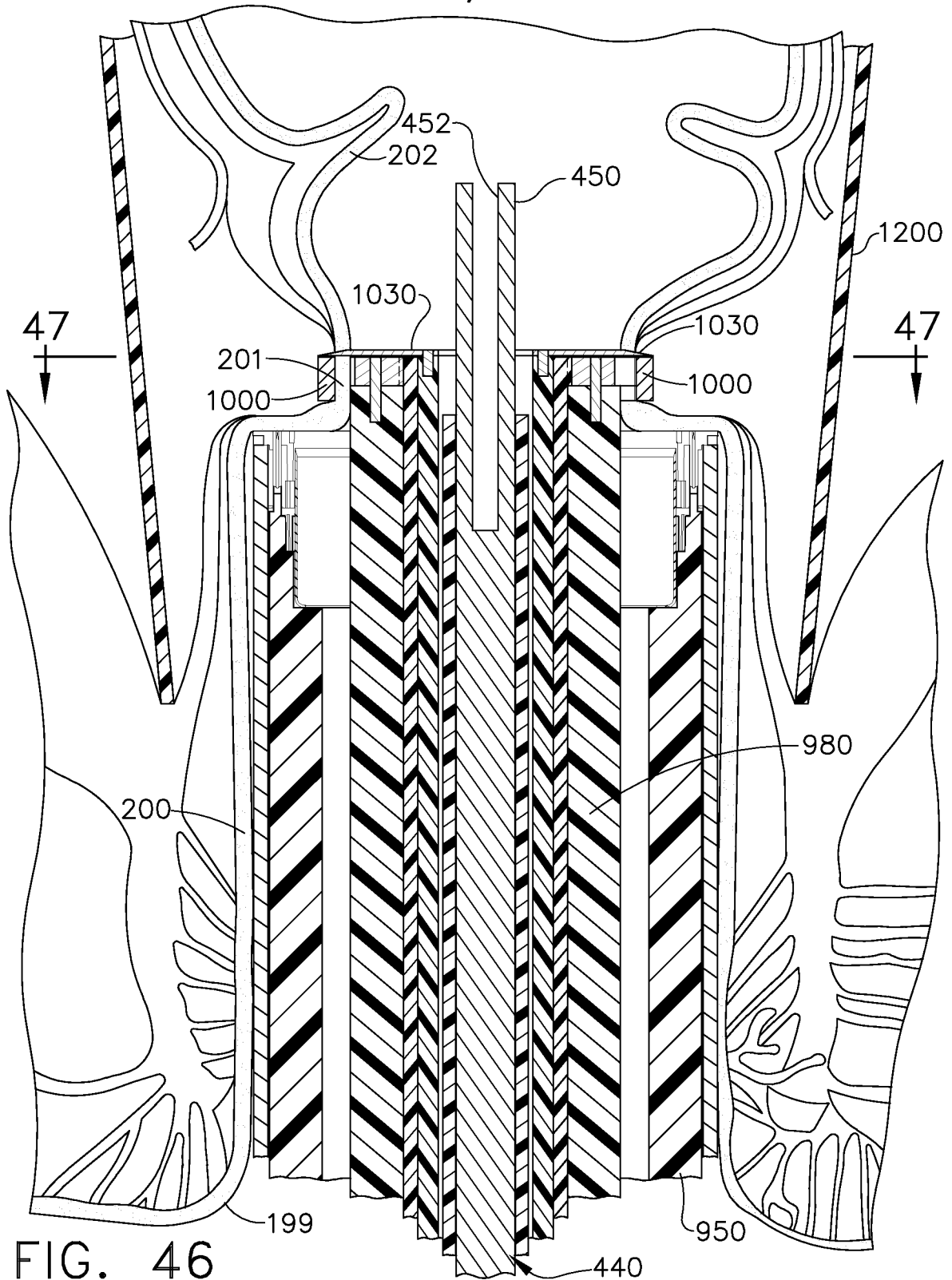

FIG. 46

50/61

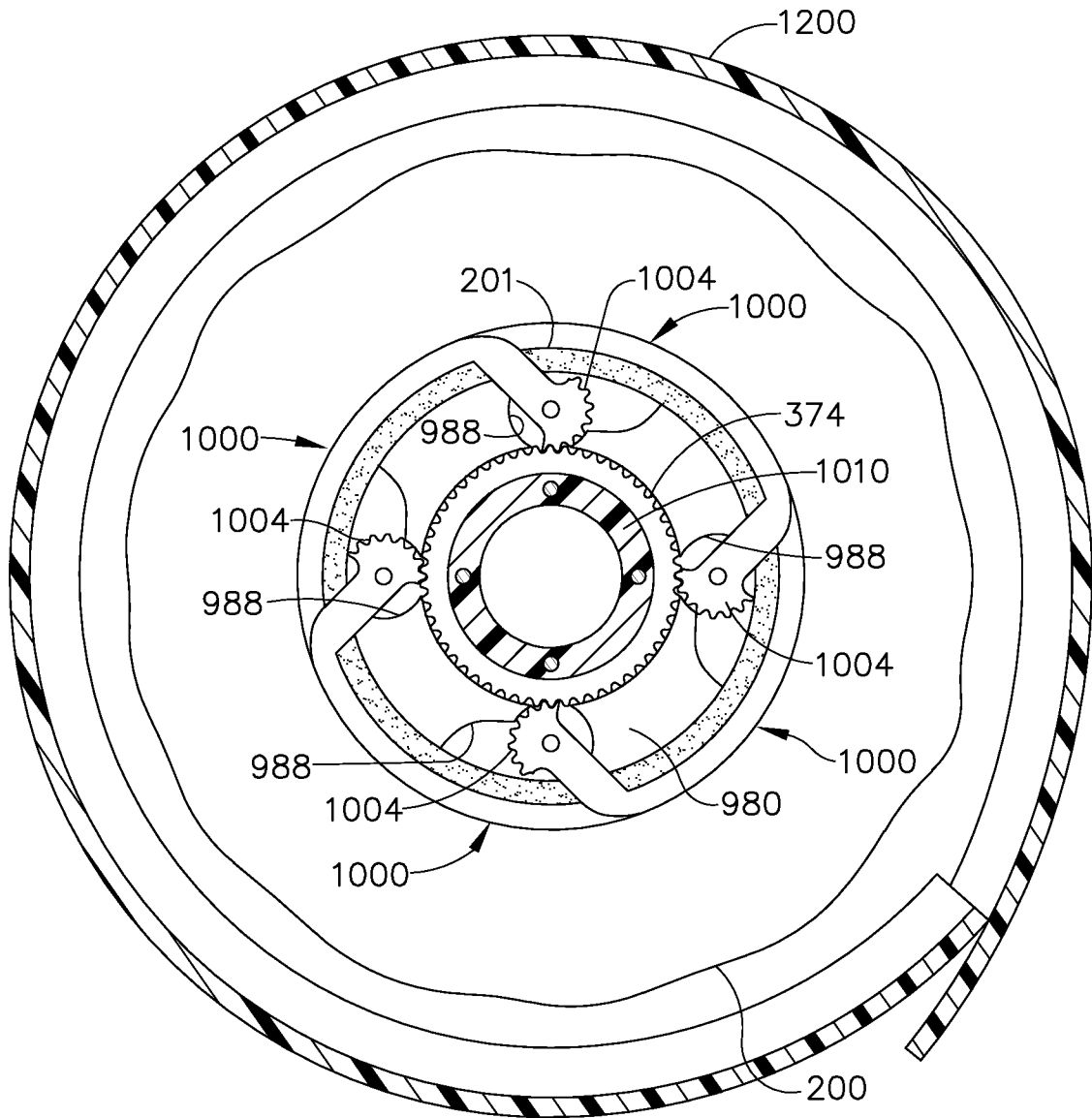
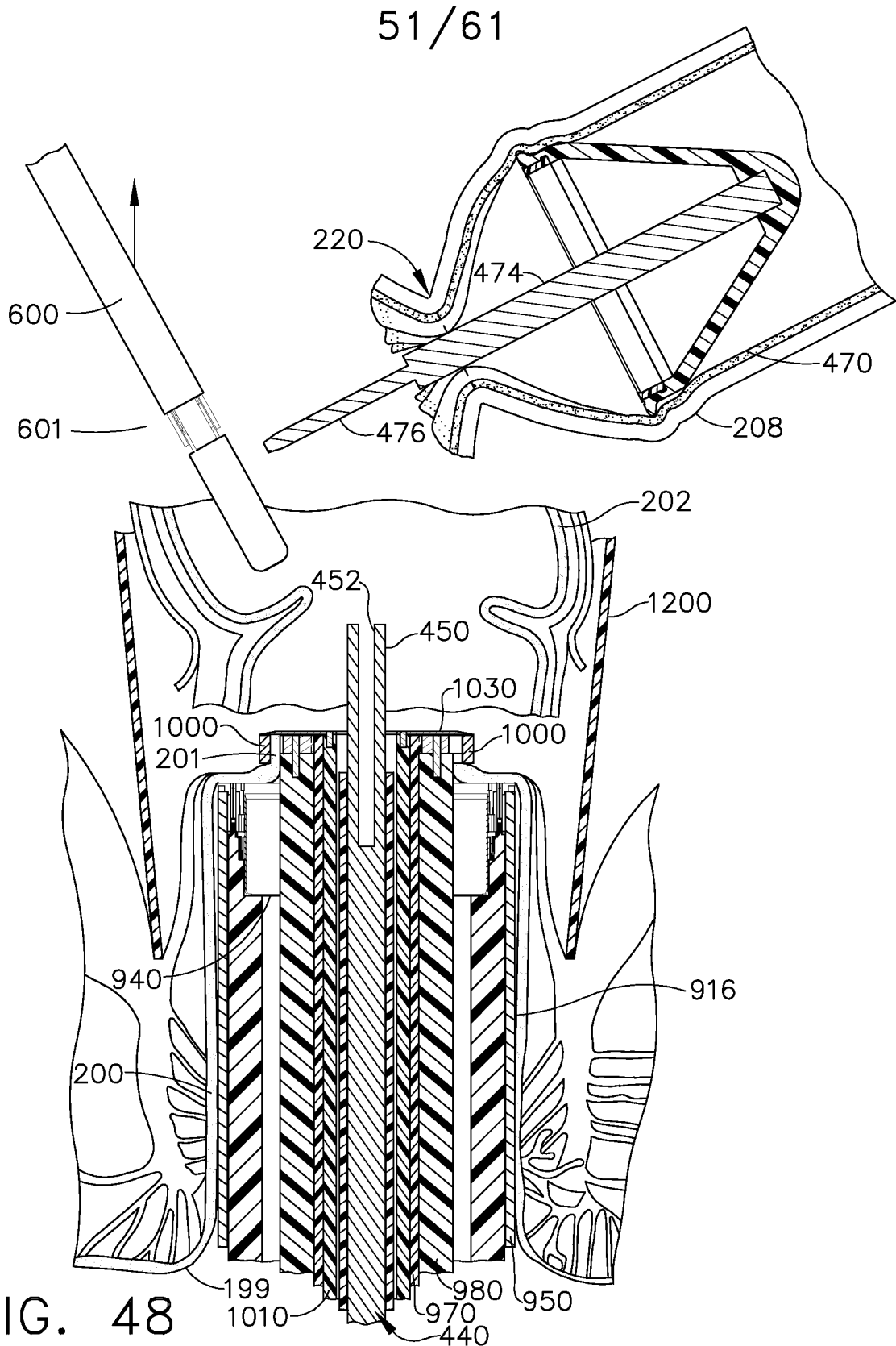

FIG. 47



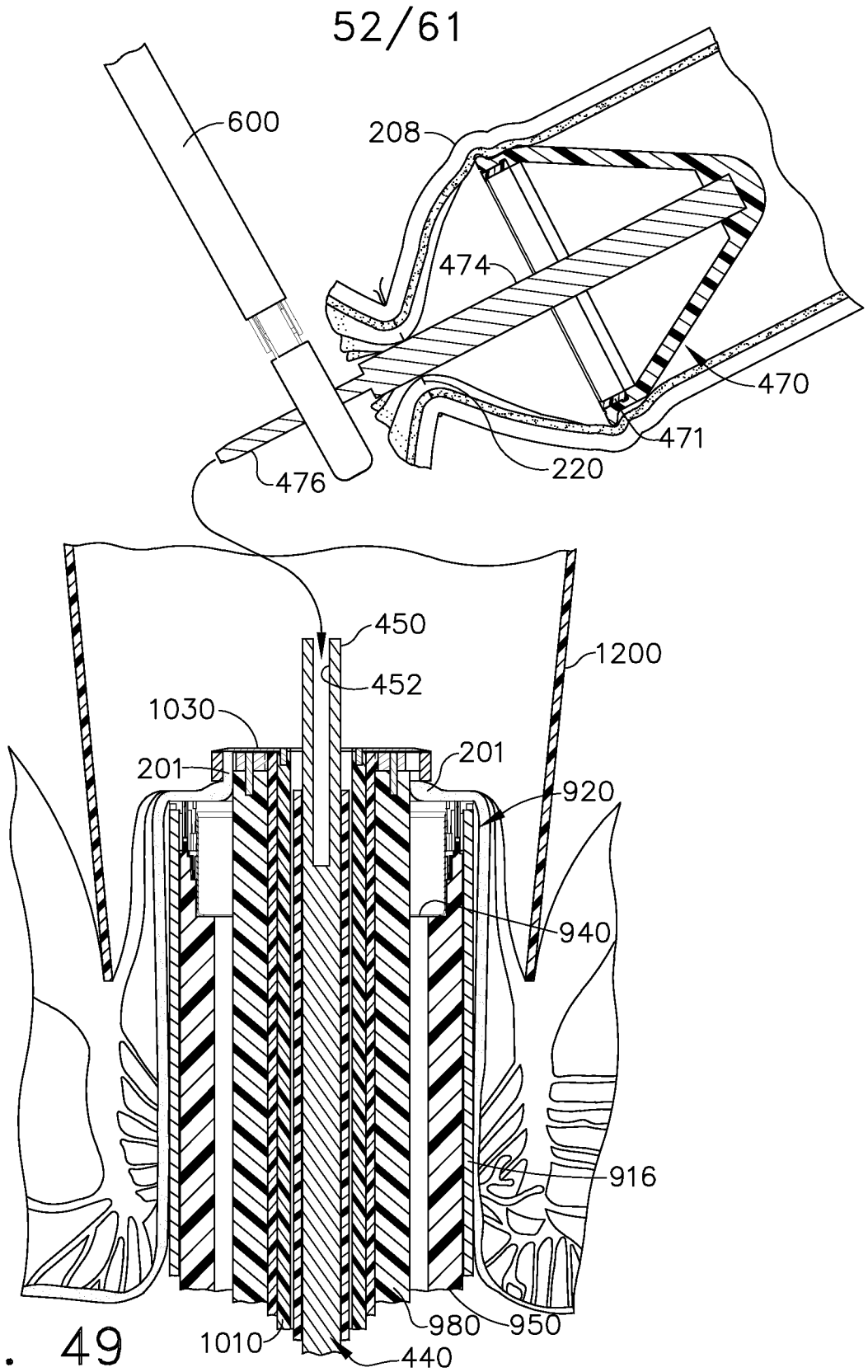
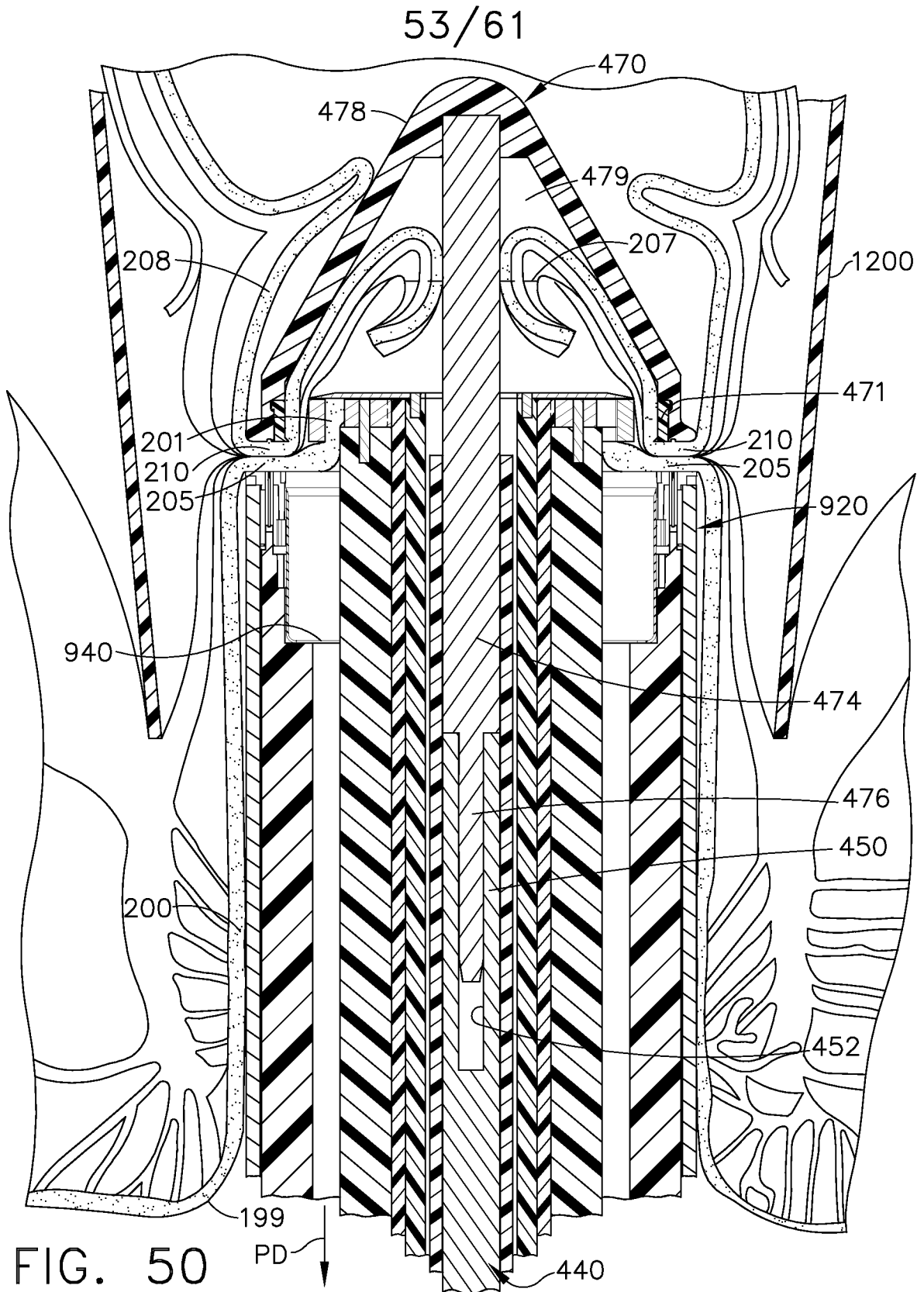
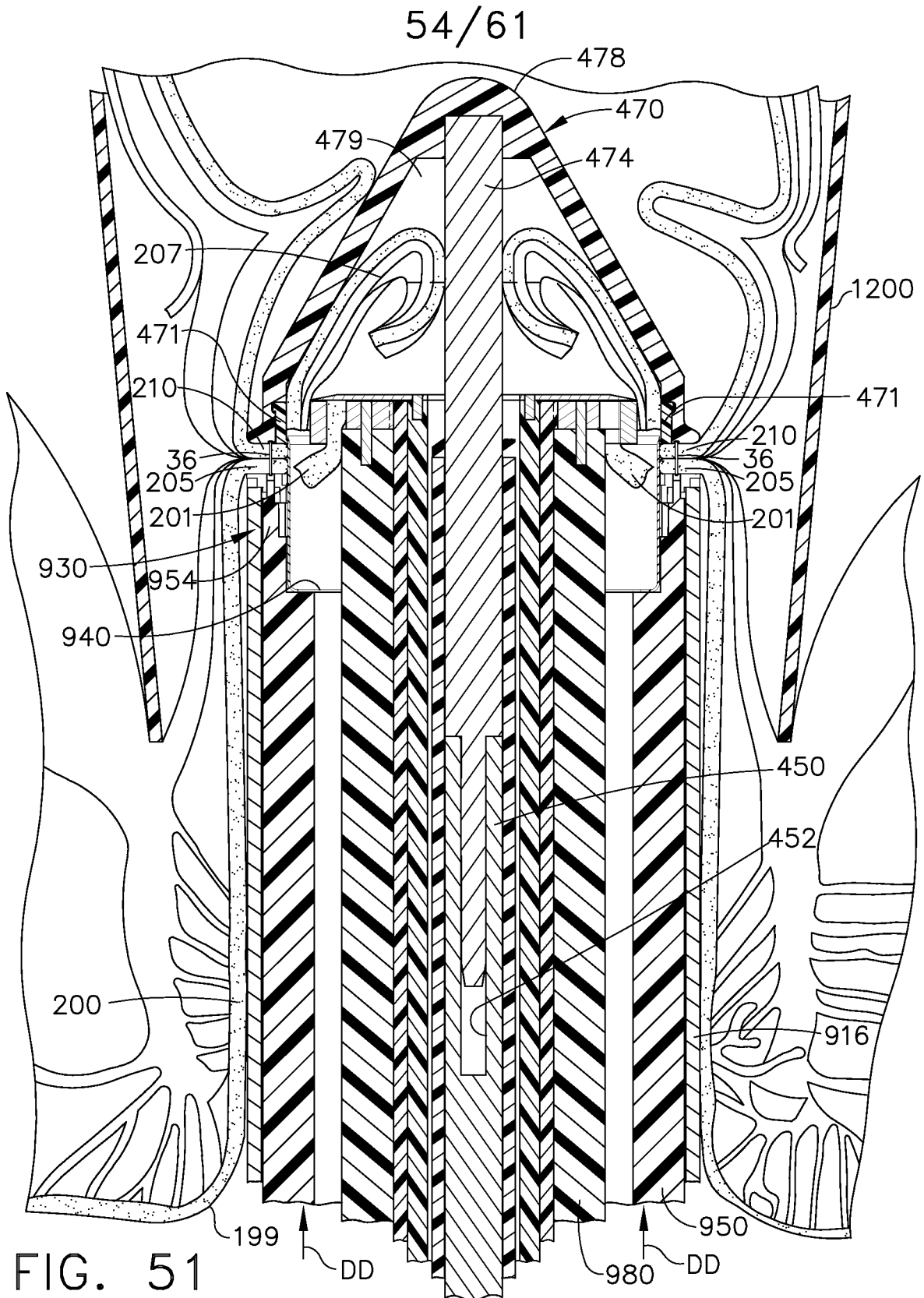
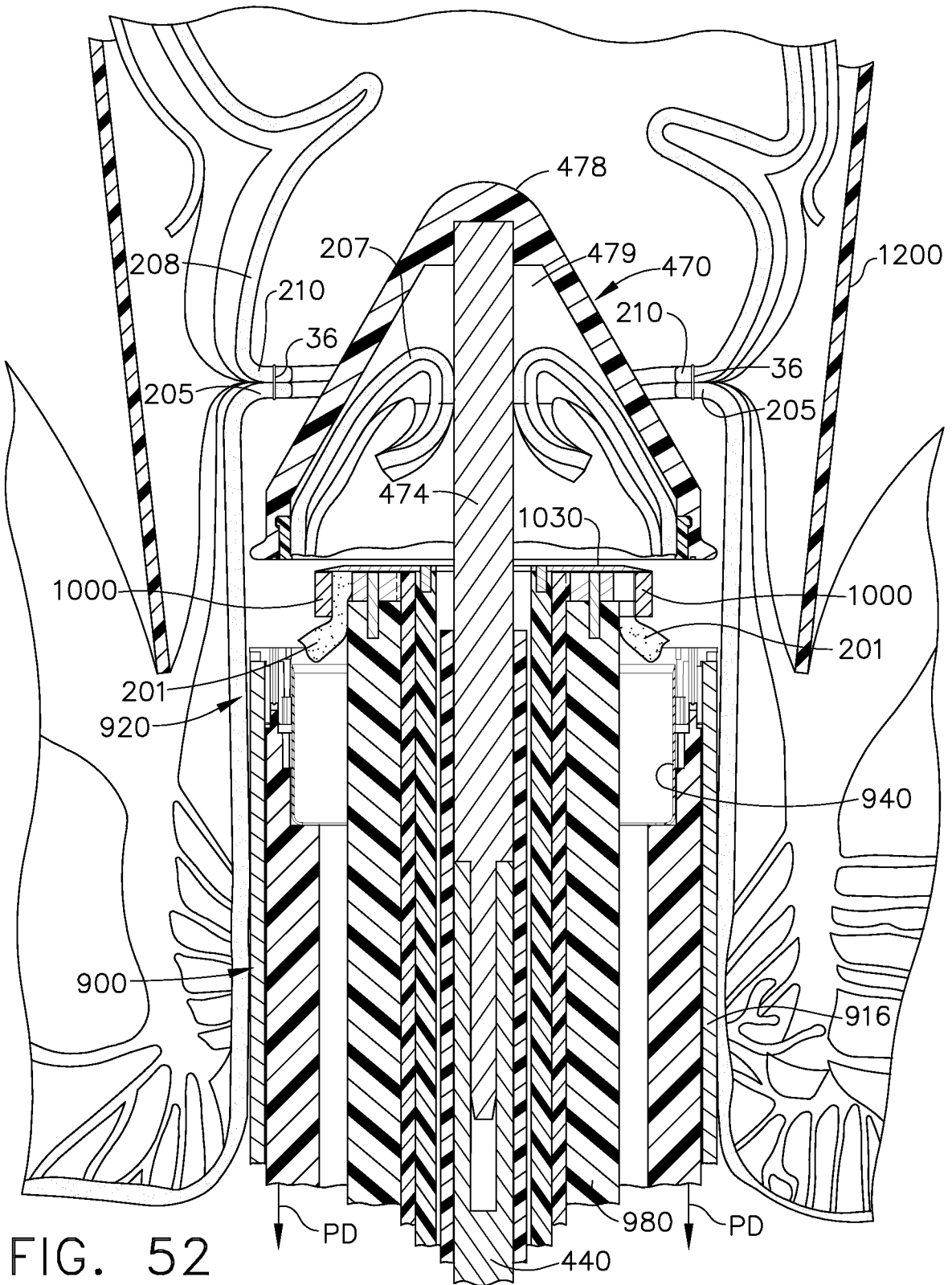

FIG. 49





55/61



56/61

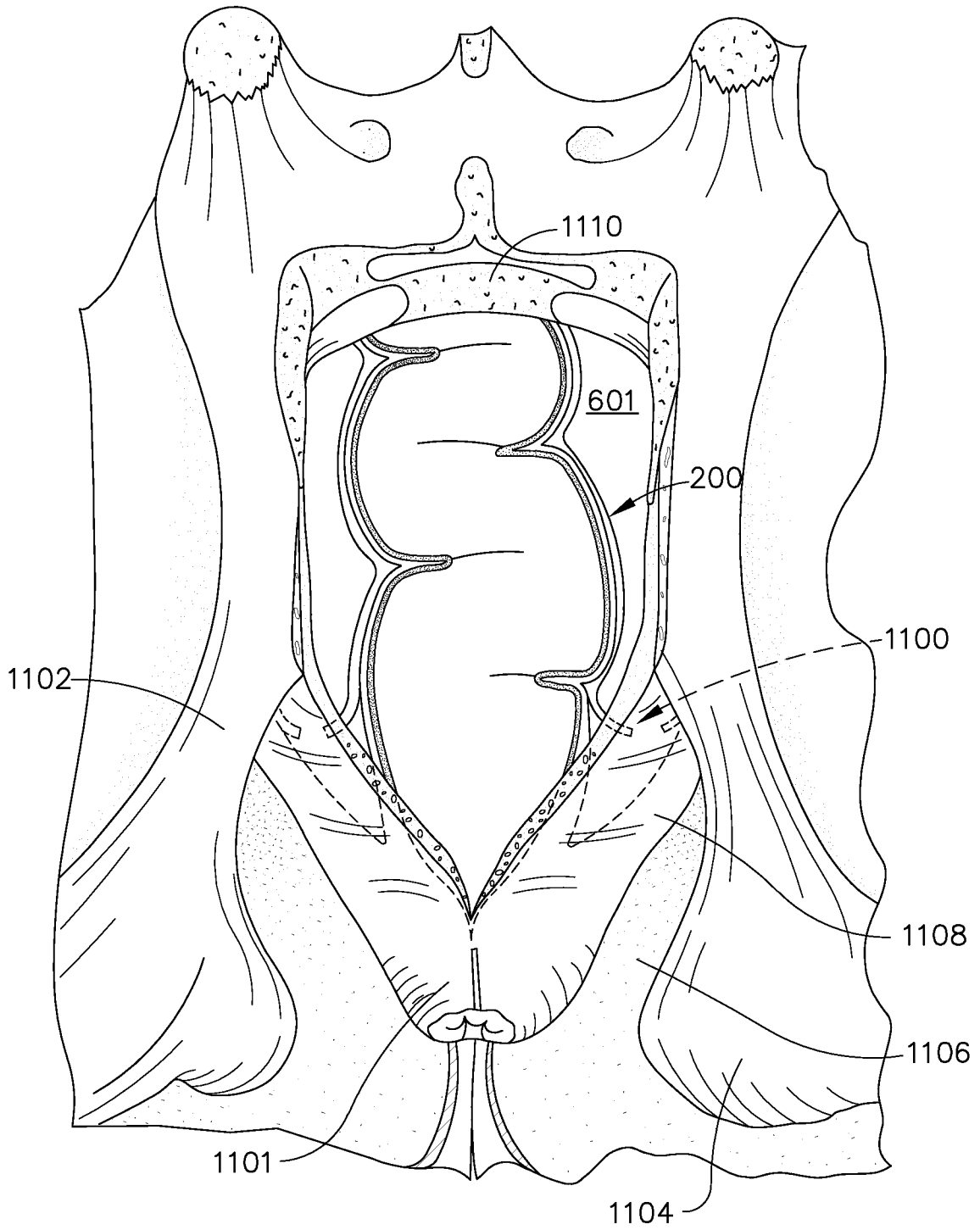

FIG. 53

57/61

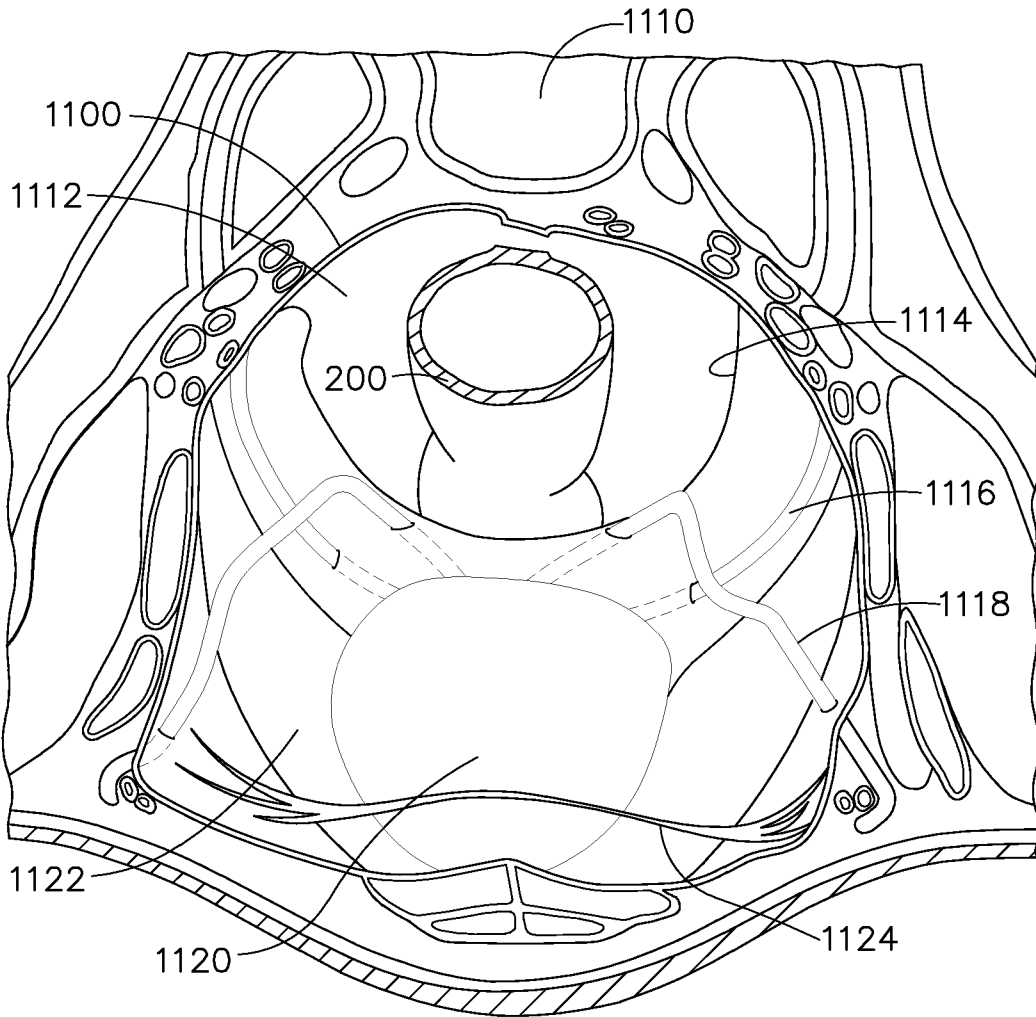

FIG. 54

58/61

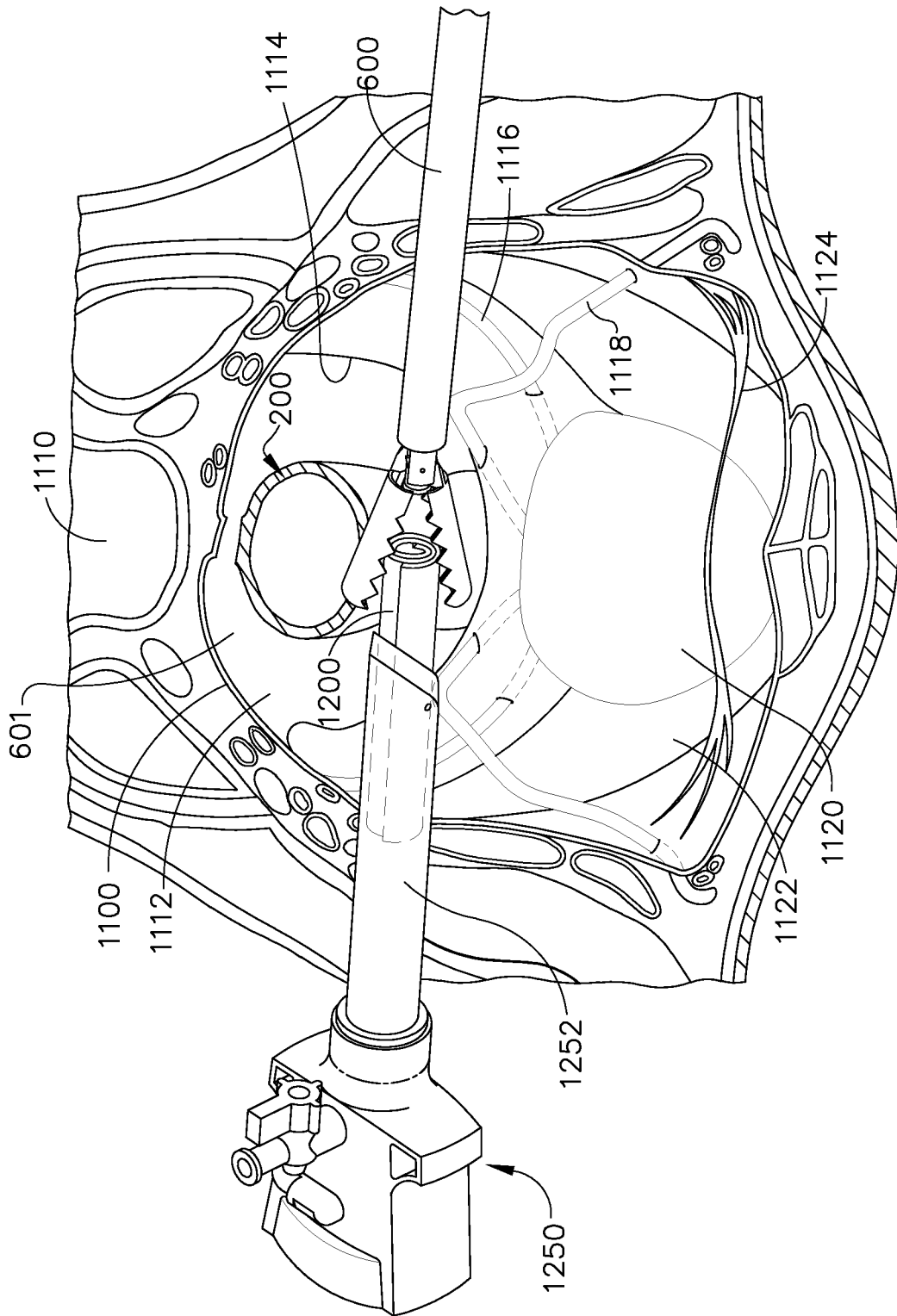

FIG. 55

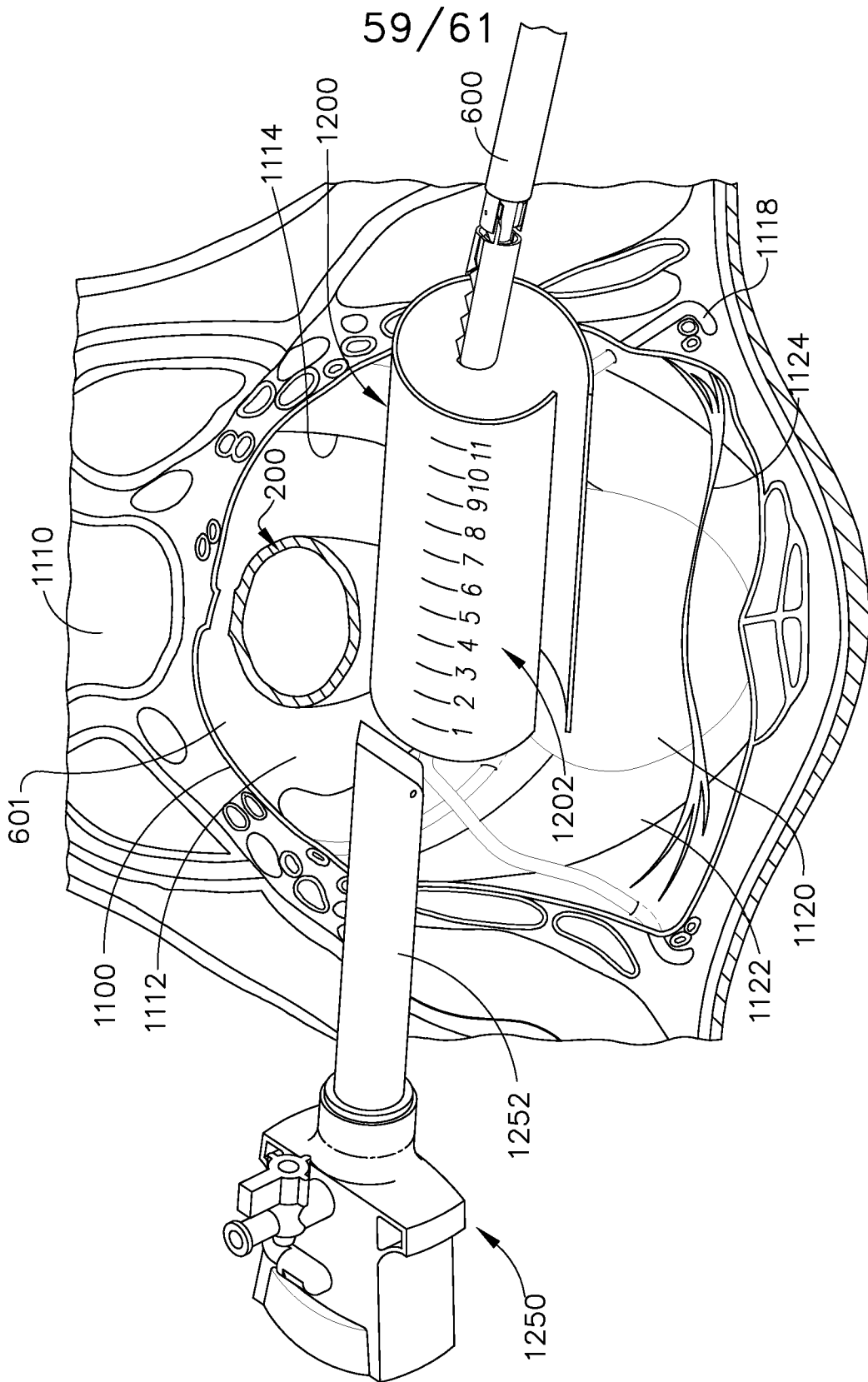

FIG. 56

60/61

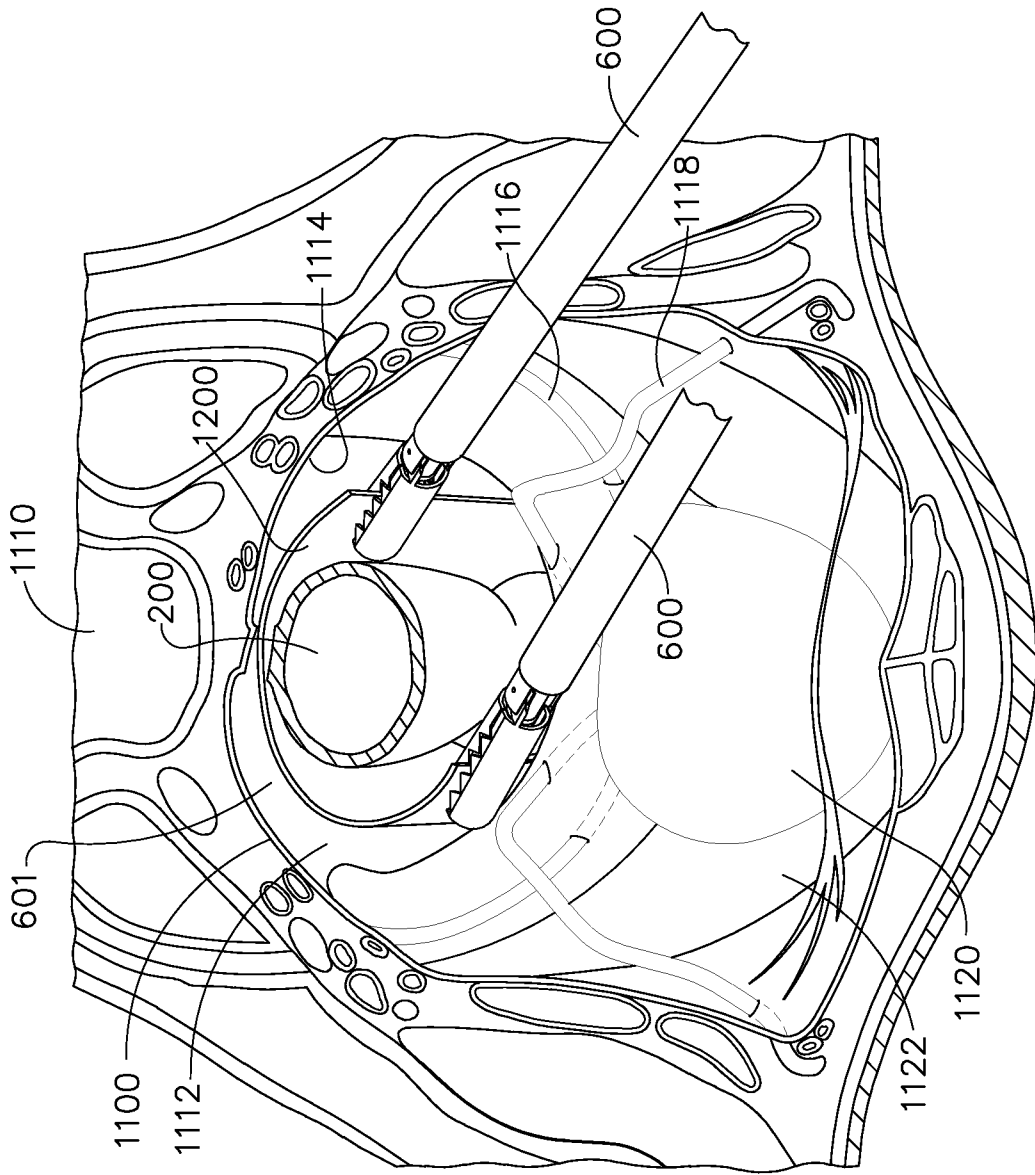

FIG. 57

61/61

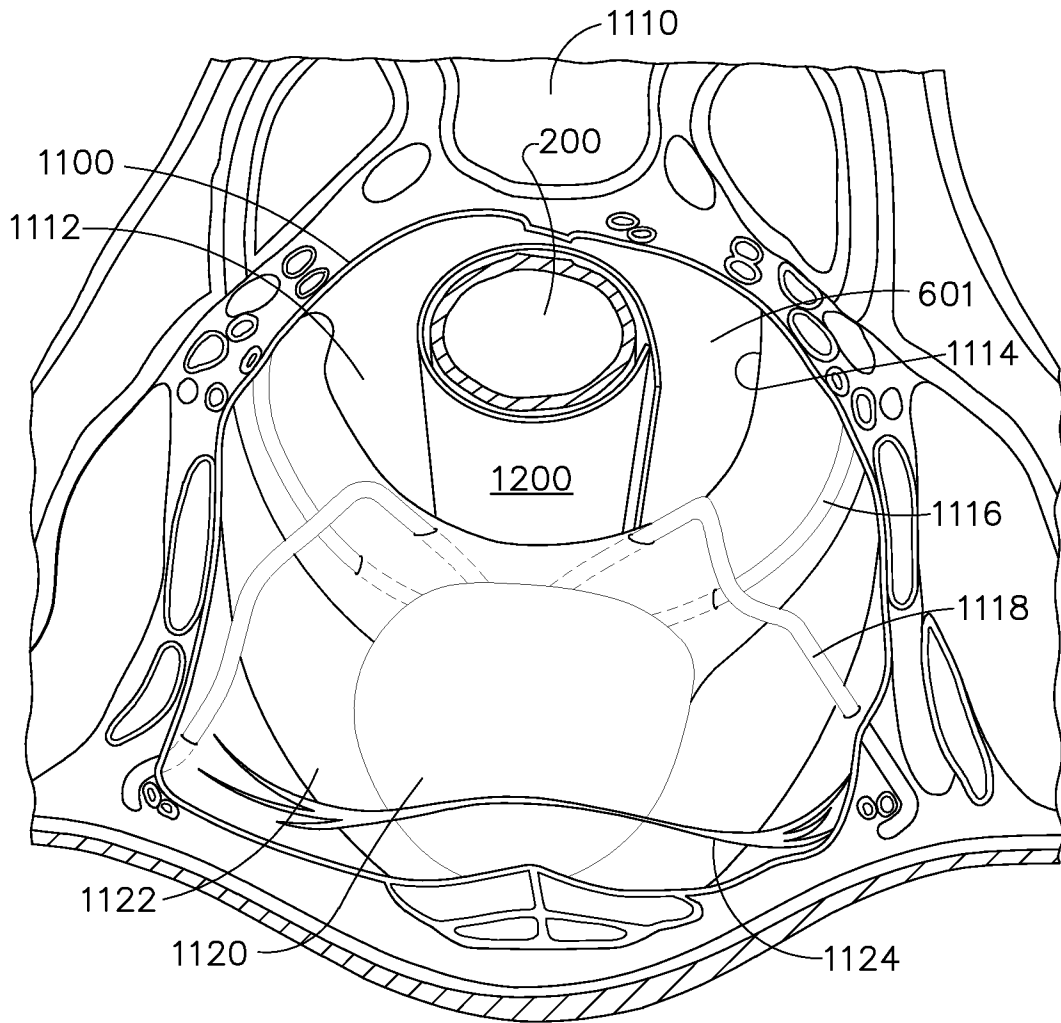

FIG. 58

INTERNATIONAL SEARCH REPORT

International application No PCT/US2011/045517

A. CLASSIFICATION OF SUBJECT MATTER INV. A61B17/11 A61B17/115 A61B1/00 ADD.				
According to International Patent Classification (IPC) or to both national classification and IPC				
B. FIELDS SEARCHED				
Minimum documentation searched (classification system followed by classification symbols) A61B				
Documentation searched other than minimum documentation to the extent that such documents are included in the fields searched				
Electronic data base consulted during the international search (name of data base and, where practical, search terms used) EPO-Internal				
C. DOCUMENTS CONSIDERED TO BE RELEVANT				
Category*	Citation of document, with indication, where appropriate, of the relevant passages	Relevant to claim No.		
Y	US 2007/135803 A1 (BELSON AMIR [US]) 14 June 2007 (2007-06-14)	1,2,4,5, 7-9, 11-14, 16,17		
A	paragraphs [0397], [0399], [0404]; figures 61-64	3,6,10		
Y	US 2005/014994 A1 (FOWLER DENNIS L [US] ET AL) 20 January 2005 (2005-01-20)	1,2,5, 7-9,11, 13-17		
A	paragraph [0033]; figures 1,2	3,4,6, 10,12		
Y	EP 2 030 578 A1 (TYCO HEALTHCARE [US]) 4 March 2009 (2009-03-04) paragraphs [0028], [0033], [0034]; figures 1,6,7	4,12,15		
----- -/--				
<table style="width: 100%; border: none;"> <tr> <td style="width: 50%; border: none;"><input checked="" type="checkbox"/> Further documents are listed in the continuation of Box C.</td> <td style="width: 50%; border: none;"><input checked="" type="checkbox"/> See patent family annex.</td> </tr> </table>			<input checked="" type="checkbox"/> Further documents are listed in the continuation of Box C.	<input checked="" type="checkbox"/> See patent family annex.
<input checked="" type="checkbox"/> Further documents are listed in the continuation of Box C.	<input checked="" type="checkbox"/> See patent family annex.			
* Special categories of cited documents :				
"A" document defining the general state of the art which is not considered to be of particular relevance "E" earlier document but published on or after the international filing date "L" document which may throw doubts on priority claim(s) or which is cited to establish the publication date of another citation or other special reason (as specified) "O" document referring to an oral disclosure, use, exhibition or other means "P" document published prior to the international filing date but later than the priority date claimed		"T" later document published after the international filing date or priority date and not in conflict with the application but cited to understand the principle or theory underlying the invention "X" document of particular relevance; the claimed invention cannot be considered novel or cannot be considered to involve an inventive step when the document is taken alone "Y" document of particular relevance; the claimed invention cannot be considered to involve an inventive step when the document is combined with one or more other such documents, such combination being obvious to a person skilled in the art. "&" document member of the same patent family		
Date of the actual completion of the international search	Date of mailing of the international search report			
14 November 2011	23/11/2011			
Name and mailing address of the ISA/ European Patent Office, P.B. 5818 Patentlaan 2 NL - 2280 HV Rijswijk Tel. (+31-70) 340-2040, Fax: (+31-70) 340-3016	Authorized officer Lee, Ronan			

INTERNATIONAL SEARCH REPORT

International application No.
PCT/US2011/045517

Box No. II Observations where certain claims were found unsearchable (Continuation of item 2 of first sheet)

This international search report has not been established in respect of certain claims under Article 17(2)(a) for the following reasons:

1. Claims Nos.: **18-20**
because they relate to subject matter not required to be searched by this Authority, namely:
The subject-matter of claims 18 - 20 appears to constitute a surgical procedure on the human body, and therefore under Rule 39.1(iv) PCT (Method for treatment of the human or animal body by surgery), these claims have not been searched; the subject-matter being deemed non-patentable.
2. Claims Nos.:
because they relate to parts of the international application that do not comply with the prescribed requirements to such an extent that no meaningful international search can be carried out, specifically:
3. Claims Nos.:
because they are dependent claims and are not drafted in accordance with the second and third sentences of Rule 6.4(a).

Box No. III Observations where unity of invention is lacking (Continuation of item 3 of first sheet)

This International Searching Authority found multiple inventions in this international application, as follows:

1. As all required additional search fees were timely paid by the applicant, this international search report covers all searchable claims.
2. As all searchable claims could be searched without effort justifying an additional fees, this Authority did not invite payment of additional fees.
3. As only some of the required additional search fees were timely paid by the applicant, this international search report covers only those claims for which fees were paid, specifically claims Nos.:
4. No required additional search fees were timely paid by the applicant. Consequently, this international search report is restricted to the invention first mentioned in the claims; it is covered by claims Nos.:

Remark on Protest

- The additional search fees were accompanied by the applicant's protest and, where applicable, the payment of a protest fee.
- The additional search fees were accompanied by the applicant's protest but the applicable protest fee was not paid within the time limit specified in the invitation.
- No protest accompanied the payment of additional search fees.

INTERNATIONAL SEARCH REPORT

International application No
PCT/US2011/045517

C(Continuation). DOCUMENTS CONSIDERED TO BE RELEVANT

Category*	Citation of document, with indication, where appropriate, of the relevant passages	Relevant to claim No.
A	US 2005/075657 A1 (BOMBARD DAVID L [US] ET AL) 7 April 2005 (2005-04-07) paragraph [0122] -----	1-17

INTERNATIONAL SEARCH REPORT

Information on patent family members

International application No PCT/US2011/045517

Patent document cited in search report	Publication date	Patent family member(s)	Publication date
US 2007135803 A1	14-06-2007	EP 1931237 A2	18-06-2008
		JP 2009507617 A	26-02-2009
		JP 2010069314 A	02-04-2010
		US 2007135803 A1	14-06-2007
		WO 2007033379 A2	22-03-2007

US 2005014994 A1	20-01-2005	EP 1643895 A2	12-04-2006
		JP 2007534350 A	29-11-2007
		US 2005014994 A1	20-01-2005
		US 2007032700 A1	08-02-2007
		US 2007032701 A1	08-02-2007
		WO 2005009211 A2	03-02-2005

EP 2030578 A1	04-03-2009	AU 2008207345 A1	19-03-2009
		CA 2638874 A1	28-02-2009
		EP 2030578 A1	04-03-2009
		EP 2266472 A1	29-12-2010
		EP 2392266 A1	07-12-2011
		ES 2353068 T3	25-02-2011
		JP 2009056306 A	19-03-2009
		US 2009056515 A1	05-03-2009
		US 2011218562 A1	08-09-2011

US 2005075657 A1	07-04-2005	US 2005075657 A1	07-04-2005
		US 2005131428 A1	16-06-2005
		US 2005154406 A1	14-07-2005
		US 2006241660 A1	26-10-2006
		US 2011101069 A1	05-05-2011
