

O. E. OSBURN.
ENGINE.

APPLICATION FILED JAN. 18, 1911.

997,694.

Patented July 11, 1911.

2 SHEETS—SHEET 1.

Fig. 1.

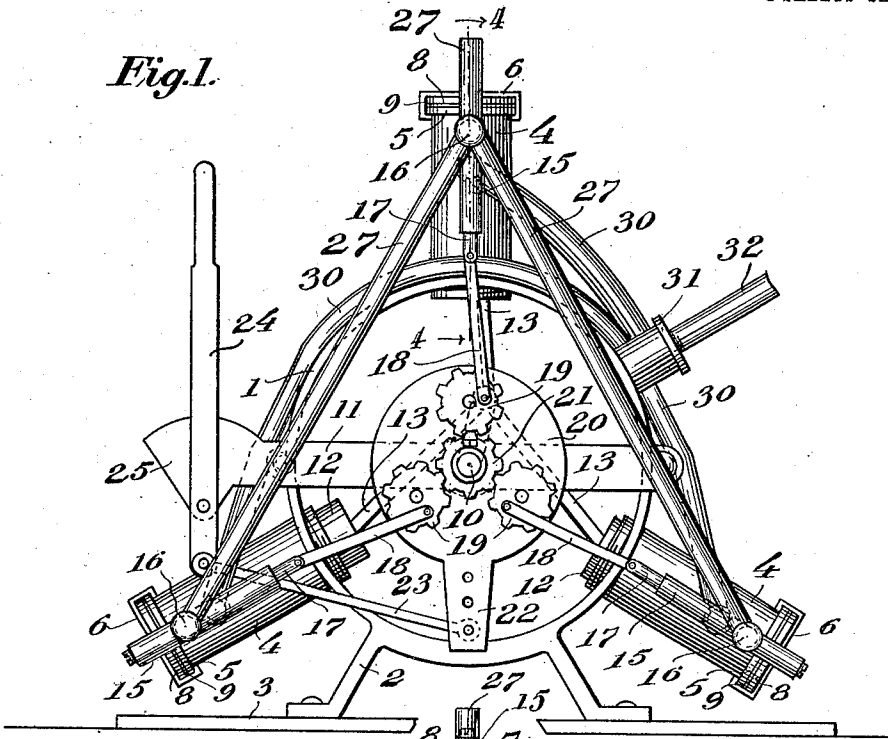
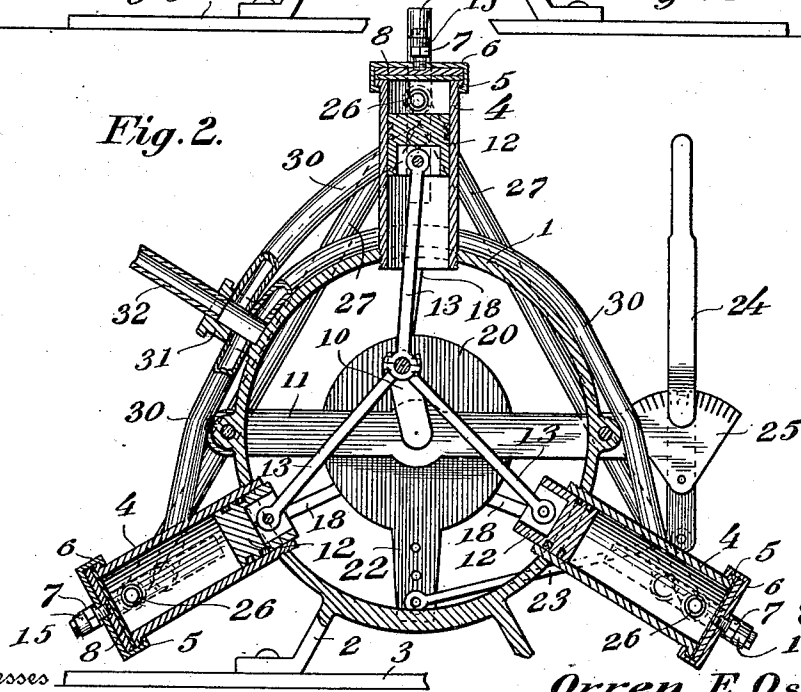

Fig. 2.



Witnesses
H. Lybrand
A. B. Hillyard.

Inventor
Orren E. Osburn
By Victor J. Evans
Attorney

O. E. OSBURN.
ENGINE.

APPLICATION FILED JAN. 18, 1911.

997,694.

Patented July 11, 1911.

2 SHEETS-SHEET 2.

Fig. 3.

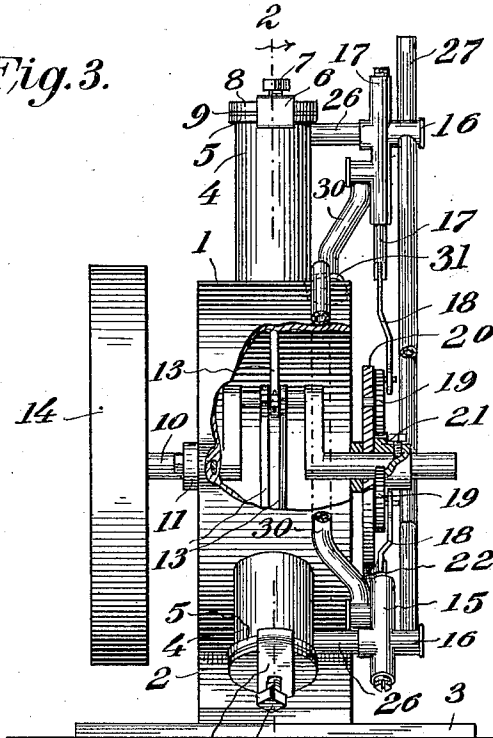
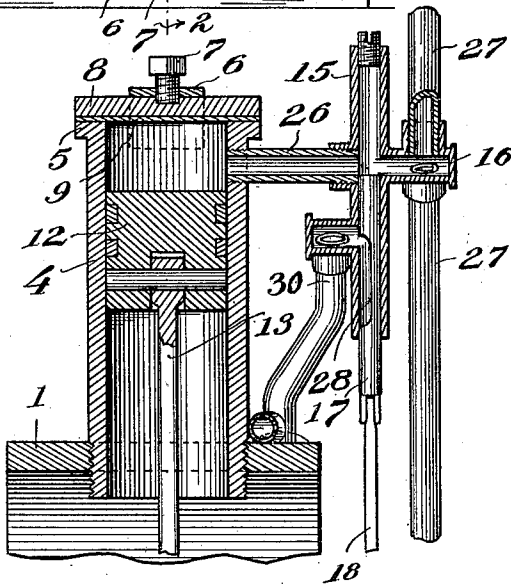

Fig. 4.



Inventor
Orren E. Osburn

Witnesses
A. H. Lybrand
C. B. Hillyard.

By Victor J. Evans
Attorney

UNITED STATES PATENT OFFICE.

ORREN E. OSBURN, OF MOSIER, OREGON, ASSIGNOR OF ONE-HALF TO GEDDES C. BANTA,
OF THE DALLES, OREGON.

ENGINE.

997,694.

Specification of Letters Patent. Patented July 11, 1911.

Application filed January 18, 1911. Serial No. 603,329.

To all whom it may concern:

Be it known that I, ORREN E. OSBURN, a citizen of the United States, residing at Mosier, in the county of Wasco and State of Oregon, have invented new and useful Improvements in Engines, of which the following is a specification.

The present invention provides a motor of the type embodying a plurality of cylinders each having a piston arranged to operate therein grouped about a frame and adapted to be operated by steam, compressed air or other suitable motive medium, the purpose being to supply an engine of compact form comprising a minimum number of parts and involving a simple construction and arrangement so that the parts are readily accessible and may be replaced at a minimum cost.

The invention consists of the novel features, details of construction and combination of parts, which hereinafter will be more particularly set forth, illustrated in the accompanying drawings, and pointed out in the appended claim.

Referring to the drawings, forming a part of the specification, Figure 1 is a side view of an engine embodying the invention. Fig. 2 is a section on the line 2—2 of Fig. 3, looking to the right. Fig. 3 is an edge view of the engine having parts broken away. Fig. 4 is a sectional detail on the line 4—4 of Fig. 1, looking to the right.

Corresponding and like parts are referred to in the following description, and indicated in all the views of the drawings, by the same reference characters.

The engine embodies a frame 1 which is of annular form and mounted upon a base 2, which in turn is secured to a bed 3 or other foundation. A number of cylinders 4 are grouped about the frame 1 and have a radial arrangement and are disposed equidistant, said cylinders being closed at their outer ends and open at their inner ends and secured to the frame 1 in any substantial way. Each of the cylinders has an outer flange 5 at its outer end, which is engaged by the hooked ends of a yoke 6, the latter having a centrally disposed threaded opening to receive a set screw 7 by means of which a plate 8 is forced close upon the outer end of the cylinder to close the same. A packing 9 is interposed between the plate 8 and the outer end of the cylinder to insure

the formation of a close joint. This construction admits of access being readily had to the cylinders for any purpose. The crank shaft 10 is mounted in bearings provided upon bars 11 which are secured to opposite sides of the frame 1. The pistons 12 arranged to operate in the cylinders 4 have their rods 13 connected to the crank portion of the crank shaft 10. As indicated three cylinders are located about the frame 1, hence the pistons connected to the crank portion thereof occupy different relative positions in their cylinders, thereby preventing the engine stopping on a dead center. A pulley 14 secured to the crank shaft 10 serves the double purpose of a fly wheel and as means for taking off power from the engine.

A cylindrical casing 15 is connected near one end with the outer end of each of the cylinders 4, said cylindrical casings consisting of short lengths of pipe which are open at their inner ends and closed at their outer ends by means of plugs 16. Piston valves 17 are arranged to operate in the cylindrical casings 15 and control the supply of motive medium to the cylinders and the exhaust of such medium after its power has been expended. The piston valves 17 operate through the inner ends of the casings 15 and are connected by pitmen 18 with pinions 19 mounted upon a plate or disk 20 having a concentric arrangement with the crank shaft 10. The pinions 19 are disposed equidistant about the crank shaft and mesh with a master pinion 21 secured to the crank shaft, said master pinion having a hub provided with a set screw, which latter serves to secure the pinion to the crank shaft in the required position. The plate or disk 20 is loose upon the crank shaft and is adapted to be turned so as to change the relative position of the pinions 19 so as to control the time of admitting the motive medium into the cylinders according to the result to be effected. An arm 22 projects from the disk or plate 20 and is connected by means of a rod 23 with an operating lever 24, which is mounted upon a toothed segment 25 forming part of one of the side bars in which the crank shaft 10 is mounted. This construction admits of turning the plate or disk 20 and securing the same in the adjusted position. A cross pipe 26 is located near the outer end of each of the cylindrical casings

15 and has its inner end connected with the
 outer portion of a cylinder 4. A supply
 pipe 27 connects the outer ends of the cross
 pipes 26 and leads from a source of motive
 5 medium supply. The piston valves 17 are
 adapted to interrupt the passage through
 the cross pipes 26 and thereby shut off a
 supply of motive medium to the cylinders
 at the proper time. Each of the piston
 10 valves has a portion cut from its inside, as
 indicated at 28, to form an exhaust passage
 for the escape of the motive medium after
 its power has been expended. A hollow pro-
 15 jection is provided upon each of the cylin-
 drical casings 15 near its inner end and an
 exhaust pipe 30 is connected thereto, said
 exhaust pipe making connection with a
 chamber 31 to which a pipe 32 connects for
 20 carrying off the exhaust to the required
 point of discharge.

In the operation of the engine motive me-
 25 dium is supplied to the pipe 27 from a suit-
 able source, the supply being admitted into
 the cylinders 4 at the proper time by means
 of the piston valves 17 and the spent me-
 dium exhausted from said cylinders by
 means of the piston valves and the exhaust
 passages 28 formed in a side thereof. The
 30 pistons are driven in successive order and
 as the crank shaft rotates the piston valves
 17 are operated by means of the pinions 19
 and 21. By operating the lever 24 the rela-
 tive position of the piston valves 17 may be
 35 changed so as to control the speed and power
 of the engine to meet certain conditions.

From the foregoing description, taken in
 connection with the accompanying draw-
 40 ings, the advantages of the construction and
 of the method of operation will be readily
 apparent to those skilled in the art to which
 the invention appertains, and while I have
 described the principle of operation of the

invention, together with the device which I
 now consider to be the embodiment thereof,
 I desire to have it understood that the de- 45
 vice shown is merely illustrative, and that
 such changes may be made when desired as
 are within the scope of the claim appended
 hereto.

Having thus described the invention what 50
 is claimed as new, is:—

An engine comprising a crank shaft, a
 plurality of cylinders grouped about the
 crank shaft, pistons arranged to operate in
 the cylinders and having connection with 55
 the crank portion of the crank shaft, a
 master pinion secured to the crank shaft and
 rotatable therewith, a plate mounted con-
 centric with the crank shaft, a plurality of
 pinions mounted upon the plate and in mesh 60
 with the master pinion, means for moving
 the plate and securing the same in the re-
 quired adjusted position, a plurality of
 casings located at one side of the cylin- 65
 ders, cross pipes connecting the respec-
 tive casings at a point midway of their
 ends with the outer ends of the respective
 cylinders, a supply pipe connecting the outer
 ends of the cross pipes, an exhaust pipe 70
 having connection with the casings near
 their inner ends, piston valves arranged to
 operate in the said casings across the said
 cross pipes and adapted to alternately estab-
 75 lish communication between said cross pipes
 and the exhaust pipe, and pitmen connecting
 the piston valves with the said pinions
 mounted upon the adjustable plate.

In testimony whereof I affix my signature
 in presence of two witnesses.

ORREN E. OSBURN.

Witnesses:

D. D. HALL,
 S. MORRIS.