

W. RAYMOND.
REGULATOR FOR FLUID COMPRESSORS.
APPLICATION FILED SEPT. 30, 1909.

Patented July 18, 1911.

3 SHEETS-SHEET 1.

998,202.

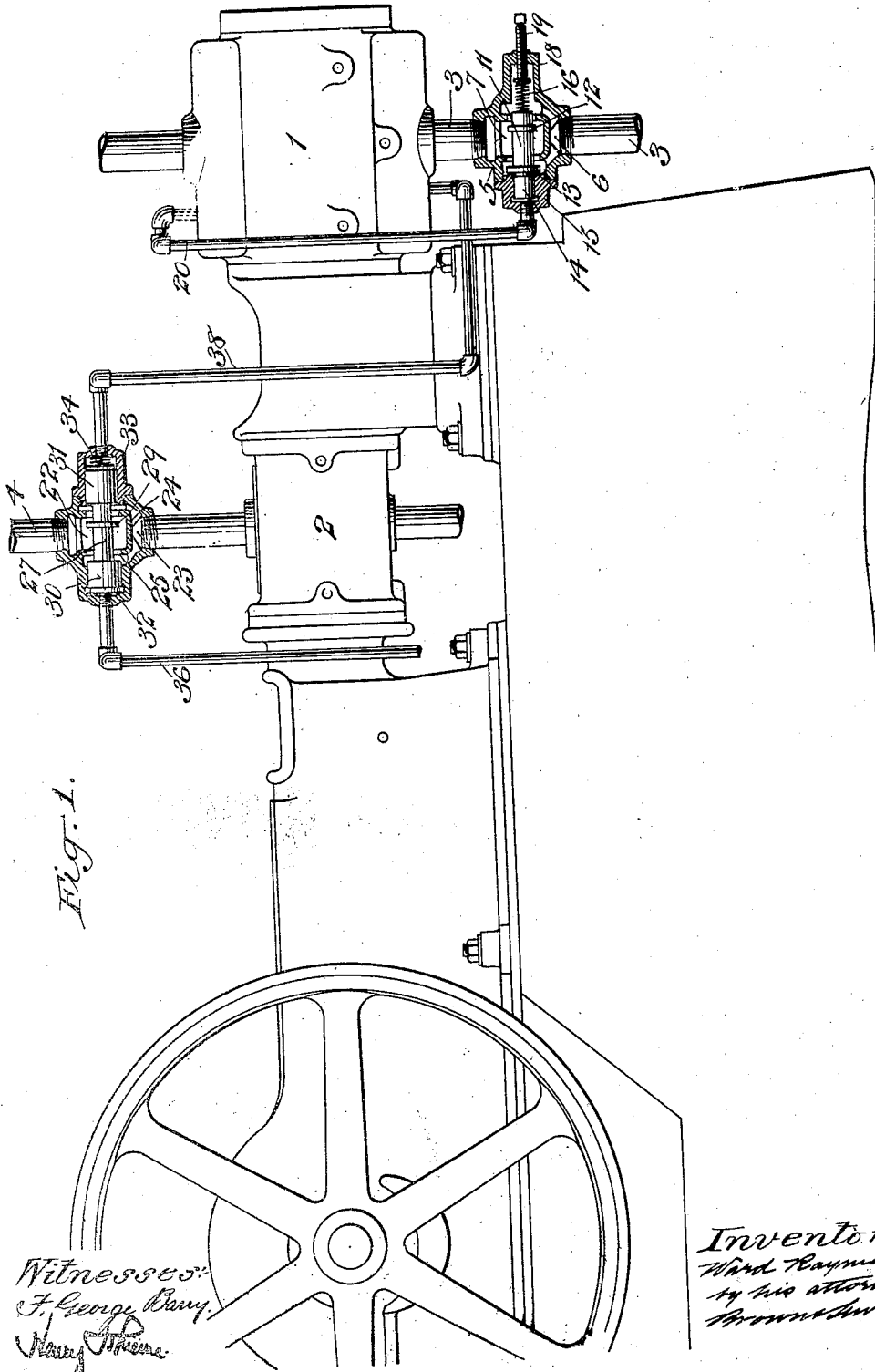

Fig. 1.

Witnesses:
F. George Barry,
Wm. J. Thomas.

Inventor:
Ward Raymond
by his attorney
Thompson & Ward

W. RAYMOND.
 REGULATOR FOR FLUID COMPRESSORS.
 APPLICATION FILED SEPT. 30, 1909.

Patented July 18, 1911.
 3 SHEETS—SHEET 2.

998,202.

Fig. 1.

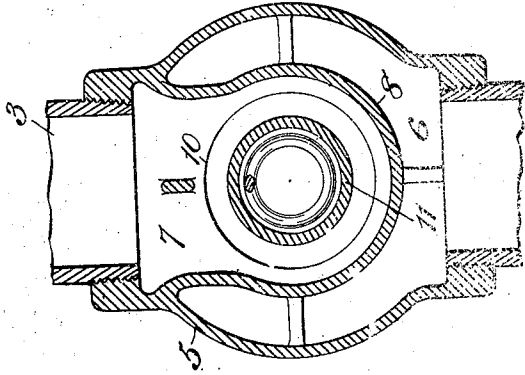
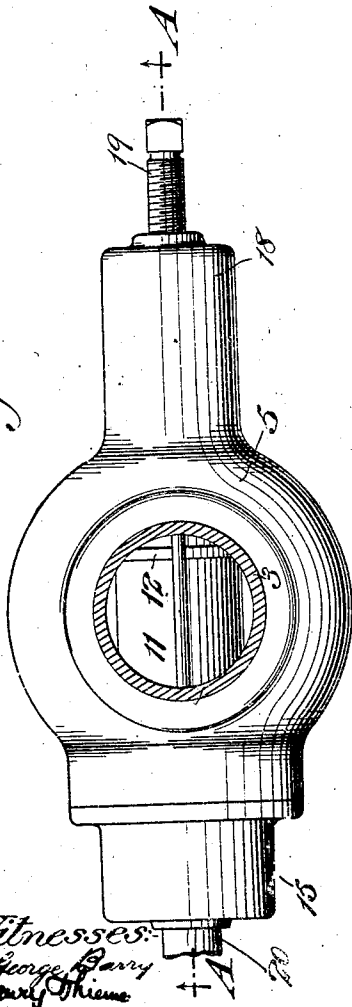
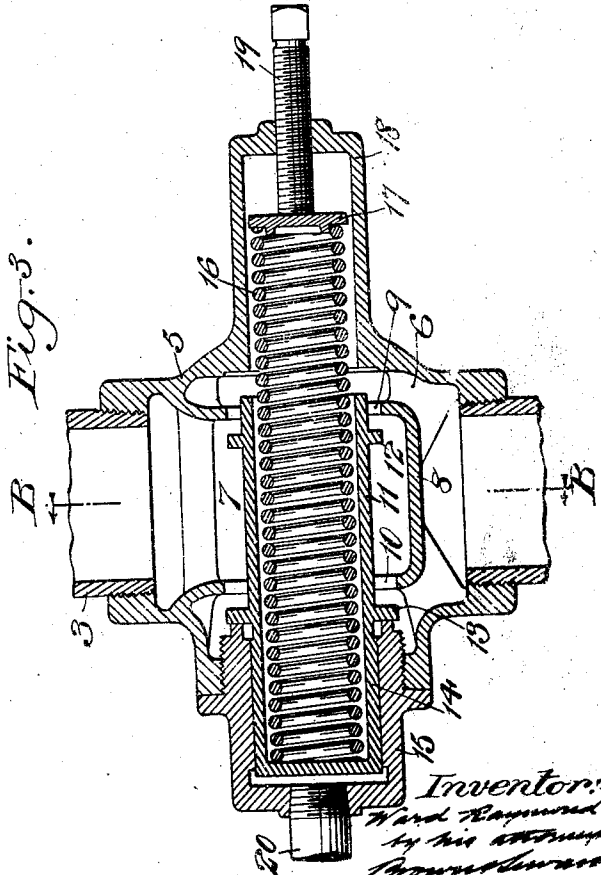

Fig. 2.



Witnesses:
George Barry
Henry Thieme

Fig. 3.



Inventor:
Ward Raymond
by his attorney
Thompson

W. RAYMOND.
 REGULATOR FOR FLUID COMPRESSORS.
 APPLICATION FILED SEPT. 30, 1909.

Patented July 18, 1911.

3 SHEETS-SHEET 3.

998,202.

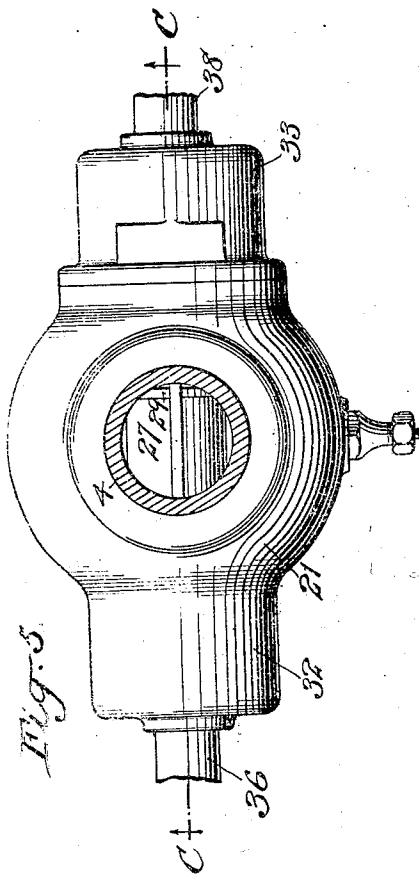

Fig. 5.

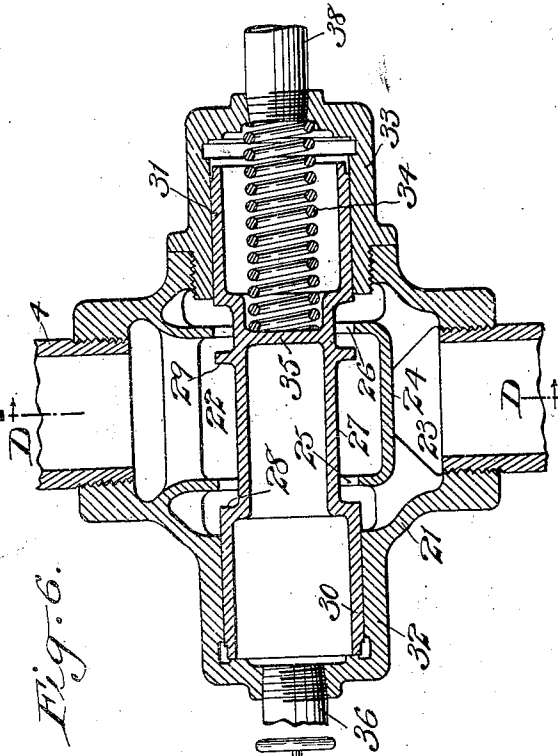
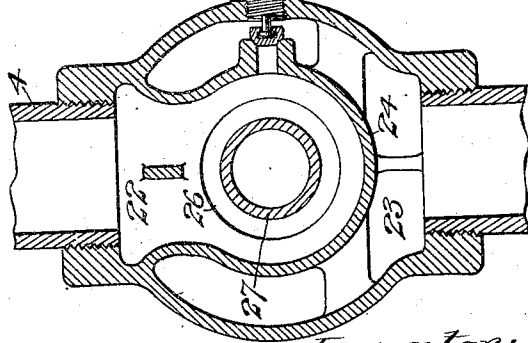

Fig. 6.

Fig. 7.



Witnesses:
F. George Barry,
Henry Thome

Inventor:
Ward Raymond
 by his attorneys
Thorn & Howard

UNITED STATES PATENT OFFICE.

WARD RAYMOND, OF EASTON, PENNSYLVANIA, ASSIGNOR TO INGERSOLL-RAND COMPANY, OF NEW YORK, N. Y., A CORPORATION OF NEW JERSEY.

REGULATOR FOR FLUID-COMPRESSORS.

998,202.

Specification of Letters Patent.

Patented July 18, 1911.

Application filed September 30, 1909. Serial No. 520,335.

To all whom it may concern:

Be it known that I, WARD RAYMOND, a citizen of the United States, and resident of Easton, in the county of Northampton and State of Pennsylvania, have invented new and useful Improvements in Regulators for Fluid-Compressors, of which the following is a specification.

The object of this invention is to provide certain improvements in regulators for air compressors whereby novel means are employed for insuring the rapid opening and closing of the intake choking controller valve and also for regulating the power utilized for driving the compressor, both of said means being under the control of a reduction in pressure in the compressor intake due to the closing of the choking controller valve.

In the accompanying drawings, a single stage straight-line steam driven fluid compressor is shown, in which—

Figure 1 represents the fluid compressor in side elevation with the choking controller and steam controller shown in section, Fig. 2 is an enlarged view in elevation of the choking controller, Fig. 3 is a section taken in the plane of the line A—A of Fig. 2, looking in the direction of the arrows, Fig. 4 is a section taken in the plane of the line B—B of Fig. 3, looking in the direction of the arrows, Fig. 5 is an enlarged view in elevation of the steam regulator, Fig. 6 is a section taken in the plane of the line C—C of Fig. 5, looking in the direction of the arrows, and Fig. 7 is a section taken in the plane of the line D—D of Fig. 6, looking in the direction of the arrows.

The fluid compressor cylinder is denoted by 1 and the steam cylinder by 2. The intake pipe which leads through the choking controller is denoted by 3 and the steam inlet pipe which leads through the steam controller is denoted by 4.

Proceeding to describe the choking controller: The choking controller valve casing is denoted by 5 and it is provided with an outer inlet chamber 6, an inner outlet chamber 7 separated by a partition 8 having ports 9, 10, of smaller and larger area, which ports are arranged to be opened and closed by a double valve 11 having flanges 12, 13, of differential areas corresponding, respectively, to the ports 9, 10. This double valve 11 is further provided with a piston head 14

fitted to slide in a cylinder 15 secured to the casing 5, the inner open end of which cylinder is arranged to be engaged by the larger flange 13 of the valve for limiting the opening movement of the valve.

A coil spring 16 is utilized for normally holding the valve in its open position, which spring is interposed between the closed end of the valve and a cap 17 located in a hollow extension 18 of the casing 5.

An adjusting screw 19 is provided for regulating the tension of the valve opening spring 16.

A pipe 20 leads from the discharge side of the compressor cylinder 1 to the interior of the cylinder 15 in front of the valve piston head 14.

The steam regulator is constructed as follows: The steam regulator valve casing is denoted by 21, which casing is provided with an inner steam inlet chamber 22 and an outer steam outlet chamber 23 separated by a partition 24 having ports 25, 26, arranged to be opened and closed by a double valve 27, the flanges of which are denoted by 28, 29. This valve 27 is provided with oppositely arranged piston heads 30, 31, arranged to slide in cylinders 32, 33, forming lateral extensions of the valve casing 21.

A valve opening coil spring 34 is located in the cylinder 33 and is interposed between the end of the cylinder and a partition 35 in the valve 27.

The cylinder 32 is open to external atmosphere as, for instance, through a pipe 36. Another pipe 38 leads from the inlet side of the compressor cylinder 1 to the interior of the cylinder 33.

In operation, when the pressure has been raised to the desired degree to overcome the force of the choking controller valve opening spring 16, the valve 11 will be started on its closing movement against the tension of the said spring due to the pressure upon the outer side of the valve piston 14 which is fed thereto through the pipe 20. As the tension of this spring 16 will increase as the valve approaches its closed position, the reduction in pressure in the chamber 7 will act upon the other side of the valve from that exposed to the increase in pressure, for overcoming the increase of pressure due to the compression of the spring 16. This is accomplished because of the differential areas of the valve flanges 12 and 13, as the

reduction of pressure in the intake pipe 3
between the valve and the compressor will
exert more influence upon the larger valve
flange 13 than it does upon the smaller valve
5 flange 12. As it is desired to also cut off the
power, as the operation of the compressor
is cut off, this will be accomplished as fol-
lows: The reduction of pressure in the in-
take for the compressor will act upon the
10 piston head 31 of the steam controller valve
27 causing the said valve to close against the
tension of its opening spring 34. As the
pressure in the compressor is reduced below
the desired amount, it will be seen that the
15 spring 16 will open the choking controller
valve 11 and as soon as the valve is started
on its opening movement, the effect of the
reduction of pressure in the intake between
the valve and the compressor is withdrawn
20 from the valve flanges thus permitting a
rapid opening of the valve. As the pressure
in the intake increases, it will permit the
spring 34 of the steam controller valve 27
to exert its pressure to open the said valve
25 thus again throwing the power onto the
compressor for driving it.

While this regulator has been shown in
connection with a straight-line steam driven
single stage fluid compressor, it is to be un-
30 derstood that it may be applied to com-
pressors of any type where such a regula-
tor can be effectively used without depart-
ing from the spirit and scope of my inven-
tion, as the said invention contemplates the
35 cutting off of the fluid admitted to the com-
pressor and also the cutting off of the power
supply for driving the compressor irrespec-
tive of the type of the compressor and the
character of the power applied for driving
40 the same.

The choking controller which is shown
and specifically described herein, forms the
subject matter of my copending application
filed September 30, 1909, Serial No. 520,334.

45 What I claim is:—

1. In combination, a compressing pump,
means for automatically reducing pressure
in the pump intake, a motor for driving the
pump and a motor regulator under control
50 of the reduction in pressure in the pump in-
take.

2. In combination, a compressing pump,
means under the control of an increase of pres-
sure on the discharge side of the pump for
55 automatically reducing pressure on the in-
take side of the pump by shutting off the

supply of fluid thereto, a motor for driving
the pump and a motor regulator under con-
trol of the reduction in pressure in the pump
intake. 60

3. In combination, a compressing pump, a
motor for driving it, a regulator for vary-
ing the pressure in the pump intake and a
regulator for the motor controlled by varia-
65 tions in pressure in the pump intake.

4. In combination, a compressing pump, a
fluid pressure operated motor for driving it,
a regulator for varying the pressure in the
pump intake and a regulator for the motor
pressure fluid supply, controlled by varia- 70
tions in pressure in the pump intake.

5. In combination, a compressing pump, a
steam operated motor for driving it, a regu-
lator for varying the pressure in the pump
intake and a regulator for the steam sup- 75
ply controlled by the variations in pressure
in the pump intake.

6. In combination, a compressing pump, a
fluid pressure operated motor for driving it,
a choking controller valve for opening and
80 closing the pump intake and a choking con-
troller valve for the motor pressure fluid
supply, controlled by variations in pressure
in the pump intake due to the operation of
the choking controller valve for the pump. 85

7. In combination, a compressing pump, a
fluid pressure operated motor for driving it,
a choking controller valve for reducing the
pressure in the pump intake and means con-
trolled by a reduction of pressure in the 90
pump intake for cutting off the fluid pres-
sure supply to the motor.

8. In combination, a compressing pump, a
fluid pressure operated motor for driving it,
a choking controller valve operated by an
95 increase in pressure on the discharge side
of the pump for cutting off the supply on
the intake side of the pump, whereby a re-
duction of pressure is produced in the pump
intake and means controlled by the reduc- 100
tion of pressure in the pump intake for cut-
ting off the fluid pressure supply to the
motor.

In testimony, that I claim the foregoing
as my invention, I have signed my name in 105
presence of two witnesses, this twenty-sev-
enth day of September, 1909.

WARD RAYMOND.

Witnesses:

A. H. TAYLOR,

CHARLES T. MILLER.