

Nov. 11, 1947.

P. L. THURSTON ET AL
CIRCULAR KNITTING MACHINE

2,430,792

Filed Aug. 8, 1944

7 Sheets-Sheet 2

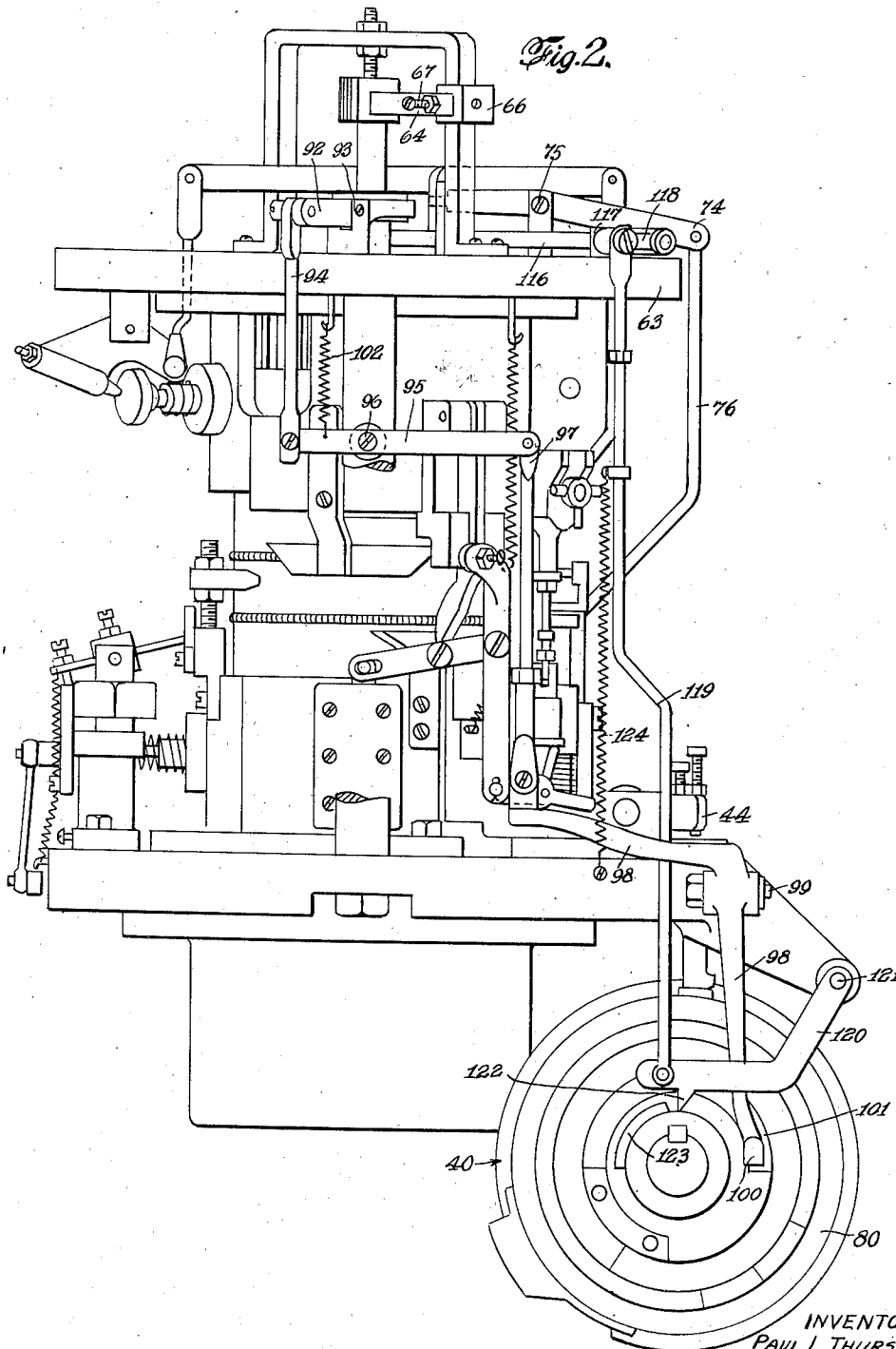

BY

INVENTORS
PAUL L. THURSTON
AND HAROLD WELKER
Robert E. Burns
ATTORNEY.

Nov. 11, 1947.

P. L. THURSTON ET AL
CIRCULAR KNITTING MACHINE

2,430,792

Filed Aug. 8, 1944

7 Sheets-Sheet 3

Fig. 3.

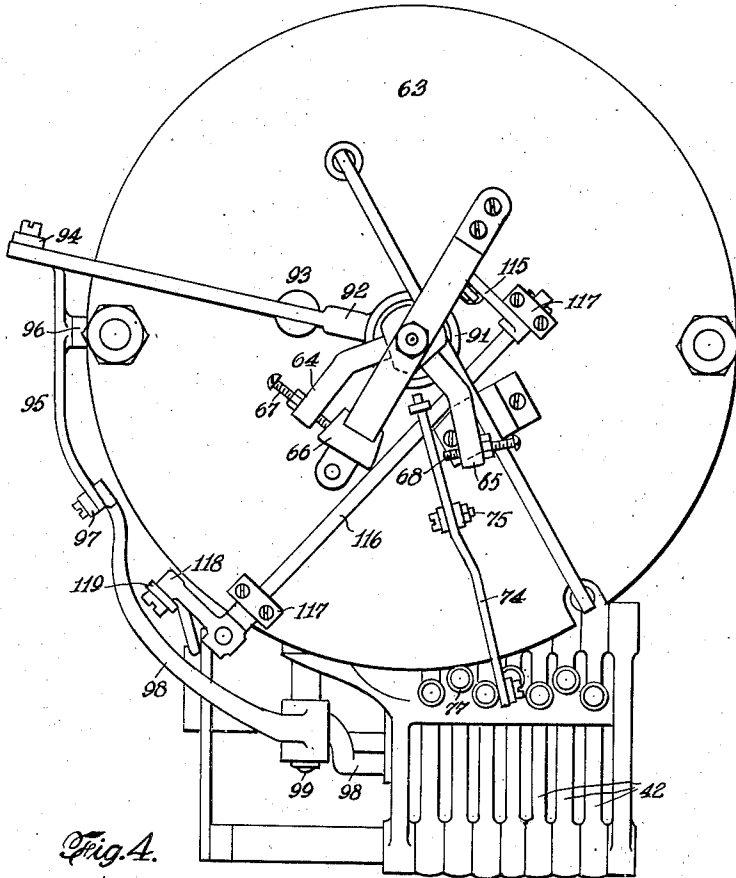
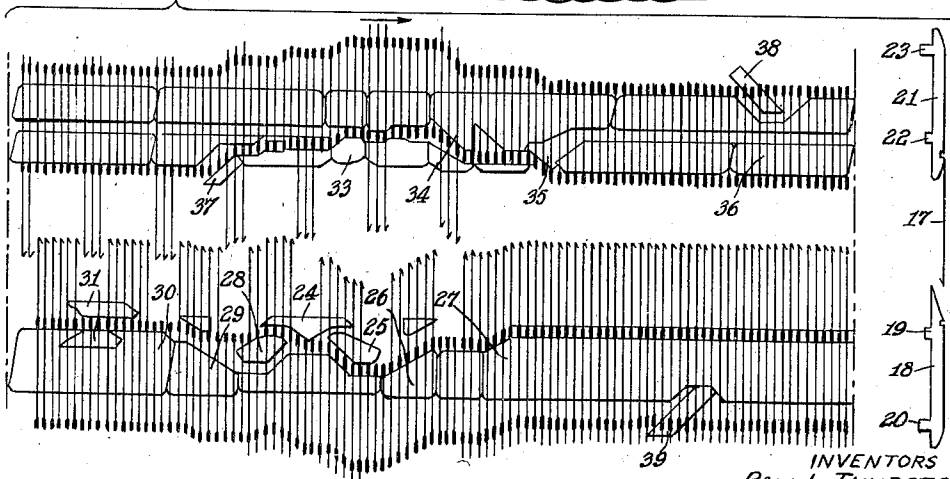

Fig. 4.



BY

INVENTORS
PAUL L. THURSTON
AND HAROLD WELKER

Robert E. Burns
ATTORNEY.

Nov. 11, 1947.

P. L. THURSTON ET AL
CIRCULAR KNITTING MACHINE

2,430,792

Filed Aug. 8, 1944

7 Sheets-Sheet 5

Fig. 6.

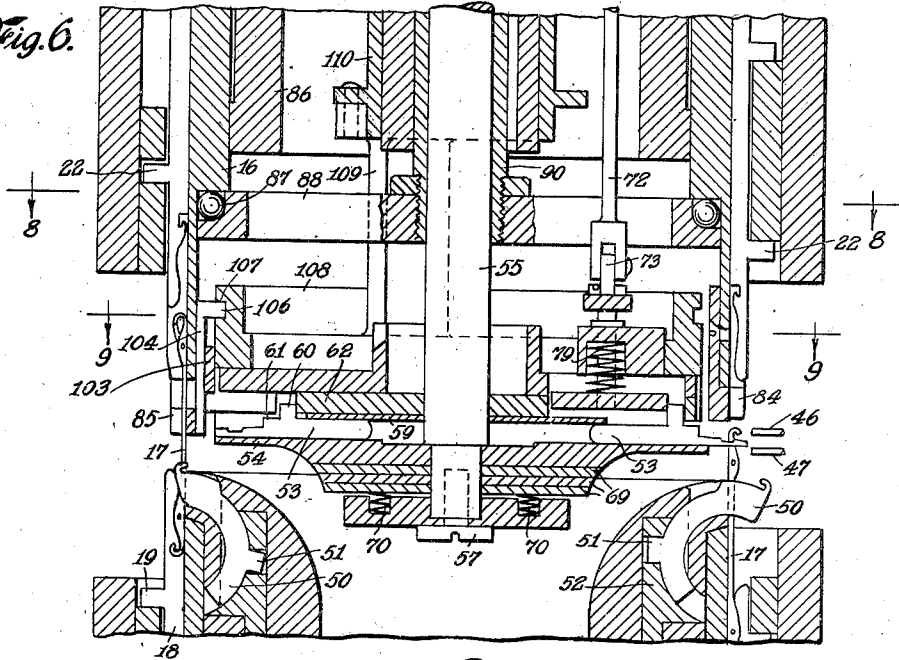
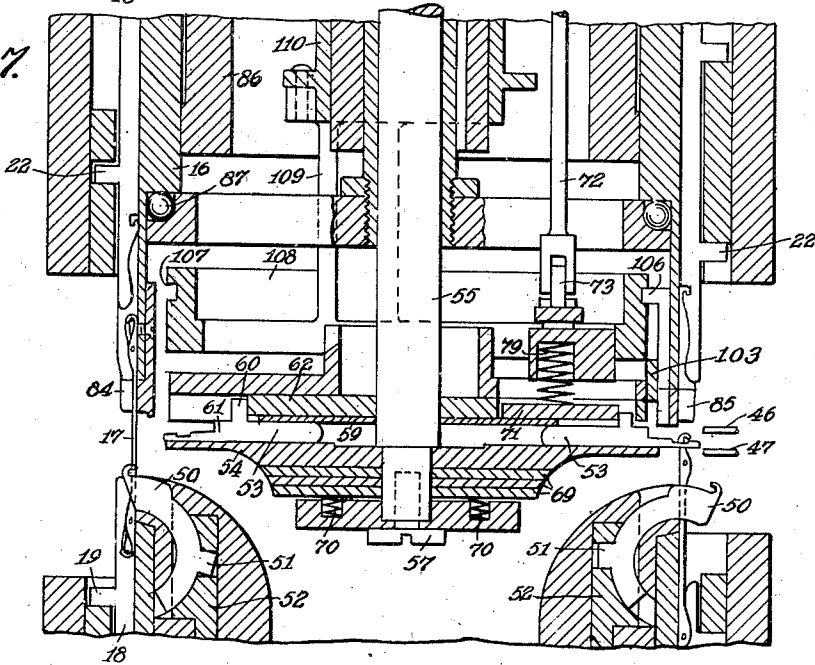

Fig. 7.



INVENTORS
PAUL L. THURSTON
AND HAROLD WELKER
BY

Robert E. Burns
ATTORNEY.

Nov. 11, 1947.

P. L. THURSTON ET AL
CIRCULAR KNITTING MACHINE

2,430,792

Filed Aug. 8, 1944

7 Sheets-Sheet 6

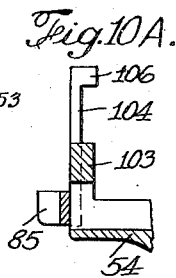
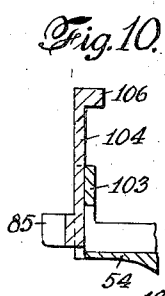
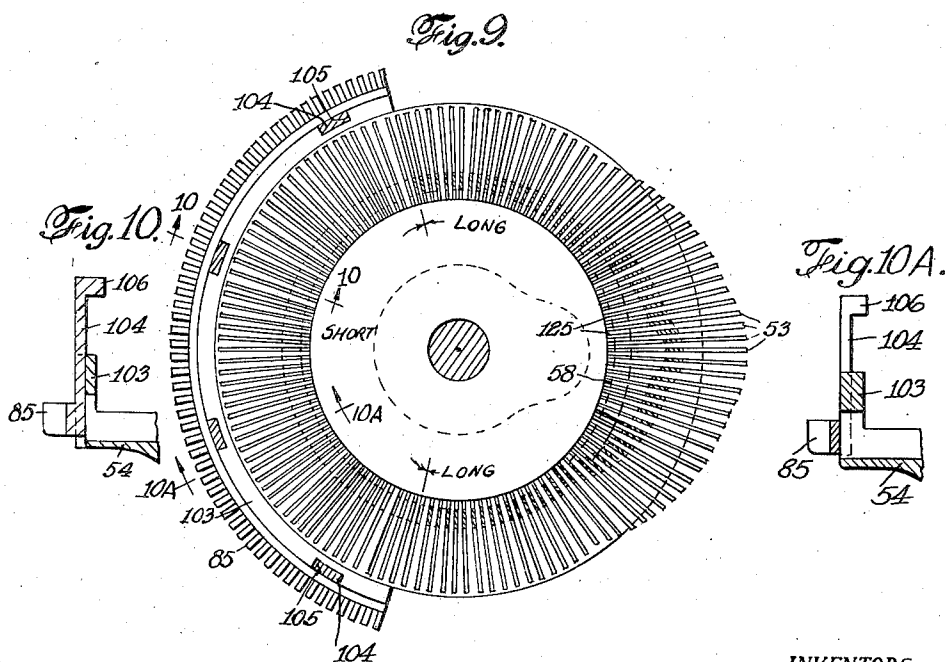
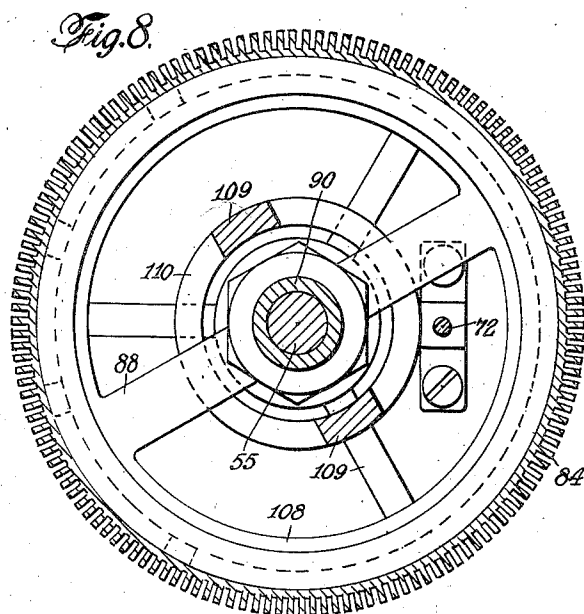

INVENTORS
PAUL L. THURSTON
AND HAROLD WELKER
BY

Robert E. Burns
ATTORNEY.

Nov. 11, 1947.

P. L. THURSTON ET AL
CIRCULAR KNITTING MACHINE

2,430,792

Filed Aug. 8, 1944.

7 Sheets-Sheet 7

Fig. 12.

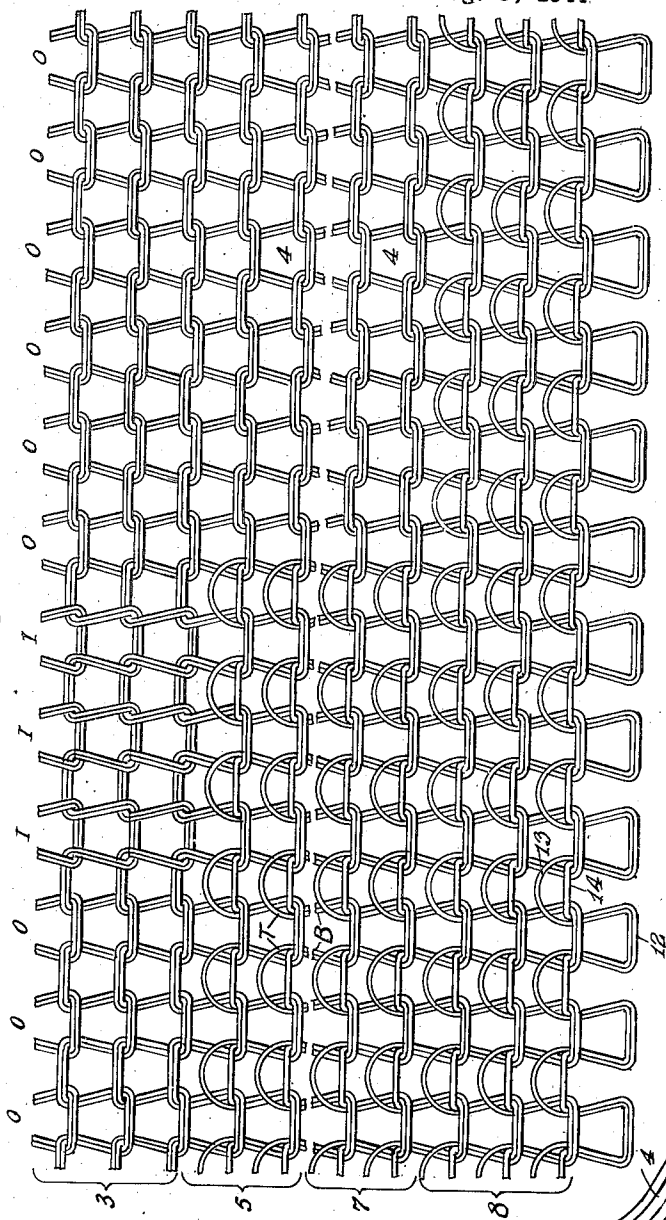
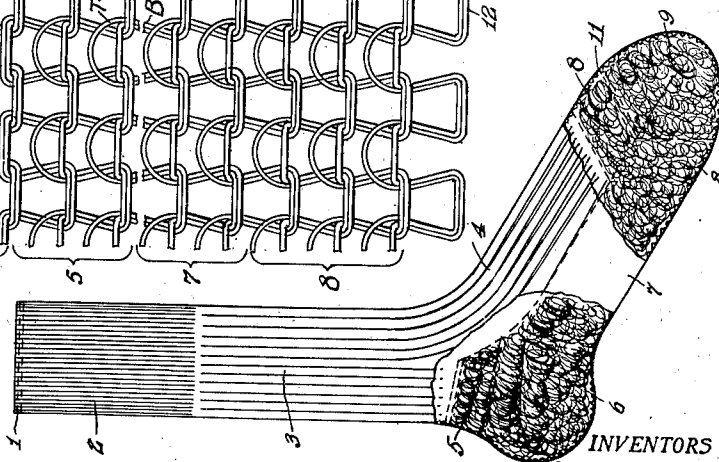

Fig. 11.



INVENTORS
PAUL L. THURSTON
AND HAROLD WELKER
BY

Robert E. Burns
ATTORNEY.

UNITED STATES PATENT OFFICE

2,430,792

CIRCULAR KNITTING MACHINE

Paul L. Thurston and Harold Welker, Martinsburg, W. Va., assignors to Interwoven Stocking Company, New Brunswick, N. J., a corporation of New Jersey

Application August 8, 1944, Serial No. 548,538

11 Claims. (Cl. 66—14)

1

Our invention consists in the novel features hereinafter described, reference being had to the accompanying drawings which illustrate one embodiment of the same, selected by us for purposes of illustration, and the said invention is fully disclosed in the following description and claims.

The present invention relates to knitting terry fabric on a circular knitting machine. The characteristic feature of terry fabric is that it has long loops hereinafter referred to as terry loops, which protrude on one or both surfaces of the fabric and provide a soft cushioning effect. Such fabric may be produced on a circular knitting machine by feeding two threads to the needles and drawing longer loops of one thread than of the other. For example, the two threads may be fed to the needles and knitted with the needle loops of the threads in plated relation, but with the sinker loops of one thread longer than the corresponding sinker loops of the other thread, to form the terry loops of the fabric. The terry loops may or may not be combed or brushed so as to separate the fibres and comingle them to form a soft matted condition on the surface of the fabric.

The invention is particularly applicable to the knitting of articles of hosiery having leg and instep portions formed of rib knit fabric, while the high splice, heel, toe, toe-band and toe portions are formed of terry fabric, to provide greater softness and resilience. To produce such articles in a continuous operation, a knitting machine must be able to produce a section of fabric composed of rib knitting throughout its coursewise extent to form the leg portion of the article, an integral section of fabric composed of rib knit fabric throughout a portion of its coursewise extent, and of terry fabric throughout the balance of its coursewise extent, to form simultaneously a rib knit instep portion and terry high splice and sole portions, and a further integral section composed of terry fabric throughout its coursewise extent to form the toe-band of the hose. The heel and toe portions, which are likewise of terry fabric, are formed by reciprocation of the needle cylinder.

A circular knitting machine of the type having superposed coaxial needle cylinders will knit rib fabric, but will not, without alteration, produce terry fabric. In knitting rib fabric on a machine of this type, selected needles or groups of needles are operated in the upper needle cylinder, and it is necessary to provide a knocking over edge or other means to cooperate with the upper cylinder needles in knitting and casting off the inwardly

2

facing stitches of the rib fabric. Such knocking over means, herein referred to generically as a "verge," is located at the lower end of the upper cylinder and somewhat corresponds in its function to the sinkers ordinarily provided at the upper end of the lower cylinder. In order to knit terry fabric on a machine of this type, instrumentalities for forming the long terry loops must be provided above the normal sinker level of the lower cylinder. These instrumentalities cooperate with needles operating in the lower cylinder to form extra long sinker loops of one of the threads fed to the needles, herein referred to as the terry thread, while the body thread is drawn over the sinkers to form sinker loops of regular length. By reason of the close spacing of the two cylinders of a coaxial knitting machine, the verge required for knitting rib fabric interferes with the proper location and operation of the above mentioned instrumentalities for producing the terry loops of terry fabric. This problem is complicated by the fact that during the knitting of the rib leg portion of the sock a knocking over edge or verge must be provided throughout the circumferential extent of the upper needle cylinder and during the knitting of the terry toe band, the terry loop forming instrumentalities must be operated throughout the circumferential extent of the needle cylinder, while during the knitting of the high splice and sole portions and the simultaneous knitting of the instep portion of the sock, a verge must be provided on the side of the needle cylinder where the instep portion is being knitted, herein referred to as the instep side of the cylinder, while terry forming bits must be in operation on the opposite side of the needle cylinder, herein referred to as the sole side of the cylinder. The complexity of a coaxial type knitting machine and the space limitations in and around the needle cylinders render it exceedingly difficult to obtain the desired combination and sequence of operations described above, and yet provide a machine which is workable and reliable.

It is an object of the present invention to overcome these difficulties and to provide a knitting machine and method of operation whereby a tubular seamless article composed partially of rib fabric, partially of terry fabric, and if desired partially of plain knit fabric can be produced commercially and economically. A further object of the invention is to provide for variations of the relative circumferential or coursewise extent of the different kinds of fabric in an integral article so as to form for example one portion of the article wholly of rib fabric, another portion

3

of rib fabric throughout part of its coursewise extent and of terry fabric throughout the remainder of its coursewise extent, and a third portion wholly of terry fabric. The term "rib fabric" is used in the specification and claims in its broader sense to include Links-Links fabric, wherein inwardly facing stitches and outwardly facing stitches are disposed in predetermined pattern arrangements, as well as straight vertical rib fabric wherein the inwardly facing stitches and outwardly facing stitches are arranged respectively in regular rows extending walewise of the fabric.

Other objects and advantages of the invention will be understood from the following description and claims in conjunction with the accompanying drawings which illustrate by way of example an embodiment selected by us to illustrate the invention.

In the drawings,

Fig. 1 is a front elevation of so much of a knitting machine as is necessary to understand the invention.

Fig. 2 is a side elevation taken from the left hand side of Fig. 1.

Fig. 3 is a top plan view.

Fig. 4 is a diagrammatic view showing certain cams for operating the needles and sliders which are shown schematically in side elevation at the right hand side of the figure.

Fig. 5 is a fragmentary vertical section showing the upper needle cylinder and adjacent portions of the lower needle cylinder with the mechanism in position for knitting the rib knit leg portion of a sock.

Fig. 6 is a fragmentary vertical section similar to the lower portion of Fig. 5, but showing the mechanism in position to knit the high splice, sole and instep portions of a sock.

Fig. 7 is a view similar to Fig. 6, but showing the mechanism in position for knitting the terry toe band of a sock.

Fig. 8 is a horizontal cross section of the upper needle cylinder taken approximately on the line 8—8 in Fig. 6.

Fig. 9 is a sectional view taken approximately at the level indicated by the line 9—9 in Fig. 6 and showing the dial carrying the instrumentalities for forming terry loops, and a verge section associated with said dial, other parts being omitted.

Figs. 10 and 10a are fragmentary sectional views taken respectively on the line 10—10 in Fig. 9.

Fig. 11 represents an article of hosiery made in accordance with our invention.

Fig. 12 is a diagrammatic representation of the stitch structure of selected portions of the article of hosiery shown in Fig. 11.

As the present invention is particularly applicable to a knitting machine having superposed coaxial needle cylinders and having instrumentalities associated with the upper needle cylinder for producing the terry loops of terry fabric as shown in Clarke's application Serial No. 453,993, filed August 7, 1942, now Patent No. 2,370,449, granted February 27, 1945, it will be described in conjunction with a machine similar to the one shown in the Clarke application. However, it will be understood that our invention is not limited to the particular machine shown by way of example in the drawing.

In Fig. 11 of the drawings there is shown an article of hosiery produced in accordance with our invention, and having a selvage or anti-ravel edge 1, a top portion 2, a leg portion 3, an instep por-

4

tion 4, a high splice portion 5, heel portion 6, sole 7, toe band 8 and toe 9. A looper line closing the toe of the sock is indicated at 11. The anti-ravel edge 1 may be of any desired type, as for example a turned welt or a single thickness elastic selvage. The top portion 2 is formed of fabric having sufficient extensibility and recoverability to pass over the heel of the wearer and yet fit the leg snugly when being worn. For example, it may be formed of plain knit, rubber incorporated fabric or of rib knit fabric with or without elastic threads. The leg portion 3 and instep portion 4 are both formed of rib knit fabric, which is preferably different from that of the top portion of the sock, the rib pattern of the front portion of the leg being continued in the instep portion 4. The high splice portion 5, heel 6, sole 7, toe band 8 and toe 9 are all formed of terry fabric. It will thus be seen that the section of fabric forming the leg portion 3 is composed of rib fabric throughout its coursewise extent. This is followed by an integral section of fabric composed of rib knit fabric throughout part of its coursewise extent to form the instep portion 4 and of terry fabric throughout the remainder of its coursewise extent to form the high splice portion 5 and sole 7. A further integral section of fabric is composed of terry fabric throughout its coursewise extent to form the toe band portion 8.

The stitch structure of the fabric is illustrated by way of example in Fig. 12. The upper portion of this figure represents a section of the leg portion 3, the central left hand portion of the figure represents sections of the high splice 5 and sole 7, the central right hand portion represents sections of the instep portion 4 and the lowermost portion represents a section of the toe band portion 8. The leg 3 and instep 4 are composed of rib knit fabric, which is shown as 6 x 3 rib, but may be any other rib knit fabric including Links-Links patterns. The high splice portion 5, sole 7 and toe band 8 are formed of terry fabrics. It will be understood that the heel 6 and toe 9 are likewise formed of terry fabric, although these portions are not specifically illustrated in Fig. 12. In the terry portion of the fabric, a body thread B and a terry thread T are knitted in such manner that the needle loops 12 are formed of both threads in plated relation, while the sinker loops are drawn separately, so that the sinker loops 13 of the terry thread T are substantially longer than the sinker loops 14 of the body thread B and constitute the terry loops of the fabric. The term "needle loops" is used herein to designate the lower portion of the stitch, i. e., the portion engaged by the needles in forming the stitch, while "sinker loops" is used to designate the upper part of the stitch, whether drawn over a sinker or other instrumentality. It will be seen that in the terry portions of the fabric, there is a terry loop 13 corresponding to each sinker loop 14 of the body thread B, so that a dense soft fabric is provided. To avoid obscuring the stitch structure, the terry loops 13 are shown shorter than they would ordinarily be in carrying out our invention. Preferably the terry loops are at least twice as long as the sinker loops 14 of the body thread. In the instep portion 4 and the leg portion 3 the same two threads, designated B and T are shown as being knitted in plated relation to form rib knit fabric, in which corresponding loops of the respective threads are of substantially the same length. Thus in the rib portion of the fabric the sinker loops of the terry thread T are of substantially the same length as the sinker loops of the body thread B. Alterna-

5

tively, the terry thread T may be omitted from the non-terry portions of the fabric, being inserted as a splice thread in the terry portions.

Referring to Fig. 12 in conjunction with Fig. 11, it will be seen that each of the courses in the section of fabric forming the instep portion 4, high splice portion 5 and sole portion 7 is knit to form terry fabric throughout part of its coursewise extent, and to form rib knit fabric throughout the remainder of its extent. In the section of fabric forming the leg portion 3, each course is knit to form rib knit fabric throughout its coursewise extent, while in the section forming the toe band portion 8 each course is knit of body thread and terry thread in such manner as to form terry fabric throughout the coursewise extent of the toe band. The relative coursewise extents of the rib fabric and terry fabric is thus carried in successive sections of an integral article.

In Figs. 1 to 10 of the drawings there is shown so much of a knitting machine as is necessary to illustrate our invention. The invention is shown by way of example embodied in a knitting machine of the type in which superimposed coaxial needle cylinders are provided with needles having hooks at both ends, suitable transfer mechanism being provided for shifting the needles from one cylinder to the other so that all of the needles may be assembled in the lower cylinder to produce plain knit fabric, or alternate needles or groups of needles may be positioned in the upper cylinder, and other needles in the lower cylinder, to produce rib knit fabric. Alternatively, the needles may be transferred back and forth from one cylinder to another in predetermined sequence controlled by pattern mechanism to produce rib knit fabric having inwardly facing stitches and outwardly facing stitches arranged to provide a pattern, such fabric being commonly referred to in the trade as Links-Links fabric. The particular machine shown in the drawings is of the type manufactured by William Spiers, Ltd. and its successors, Wildt & Co., Ltd., both of Leicester, England, and certain parts which are not necessary to an understanding of the invention have been omitted for the sake of clearness.

The knitting machine illustrated by way of example in the drawings has a lower needle cylinder 15 (Fig. 5) an upper needle cylinder 16, and a circular series of needles 17 having a hook and latch at each end and operable in either cylinder. When in the lower cylinder, the needles are operated by sliders 18 engaging the lower hooks of the needles and having knitting butts 19 and transfer butts 20 (Fig. 4) adapted to engage needle operating cams. Preferably, the sliders operating the needles on the "sole" side of the cylinder, i. e., the side on which the high splice, heel, sole and toe of an article of hosiery are knit, have short knitting butts, while the sliders for needles on the opposite side of the cylinder, i. e., the "instep" side have long knitting butts. When in the upper cylinder the needles are operated by similar sliders 21 having knitting butts 22 and transfer butts 23 engaging suitable operating cams.

The cams for operating the needles are shown diagrammatically in Fig. 4 where the direction of movement of the needles and sliders relative to the cams when the machine is operated by continuous rotation, is from left to right as indicated by the arrow. The needles operating in the lower cylinder pass through a knitting wave as shown, being drawn down by center cam 24 and stitch cam 25 to draw loops of thread fed to the needles

6

and cast off previously drawn stitches. The needles are then raised by riser cam 26 and clearance cam 27 to a clearing position in which the newly drawn loops are placed under the latch.

When the cylinder is rotated in the opposite direction, as when oscillated during the knitting of the heel and toe, the lower cylinder needles are drawn down by center cam 24 and heel stitch cam 28 and are thereafter raised to clearing position by heel riser cam 29 and heel clearing cam 30. During the knitting of the heel and toe the lower cylinder needles on the instep side of the cylinder are raised by vertically movable switch cams 31 to an inactive position in which they hold their stitches.

The cams for operating the needles when in the upper cylinder include a stitch cam 33 and clearing cam 34. The upper cam block is also provided with a welt cam 35 which can be withdrawn to allow the knitting butts of the upper cylinder sliders 21 to pass through an idle track 36 so that the upper cylinder needles will hold their stitches without knitting and with a switch cam 37 operable in conjunction with lower cylinder switch cams 31 to render the needles on the instep side of the cylinder inactive during the knitting of the heel and toe. The machine is also provided with an upper transferring cam 38 and a lower transferring cam 39 which are movable inwardly and outwardly and act on transfer butts of different lengths to transfer needles from one cylinder to the other as required for the particular article being knit.

The movable cams, such as the transfer cams, welt cam and switch cams, are moved into and out of operative position by suitable mechanism controlled for example by a pattern drum 40 which is intermittently racked during the knitting of the article and has cams such as cam 41 acting through pivoted arms 42 and tappets 43 to actuate rocker arms 44 which are connected by suitable mechanism with the respective cams. As the control of such cams by a pattern drum is well known in the art it will not be described in further detail.

At a point on the needle circle adjacent the center cam 24 there is provided a feeding station for feeding thread to the needles. At this feeding station the body thread B and terry thread T are fed in spaced relation so that the instrumentalities for forming the terry loops of the terry fabric can come between them and separate the two threads. In Figs. 5, 6 and 7 of the drawings the feed for the terry thread T is indicated schematically as a feed finger 46 and the feed for the body thread B is shown schematically as a feed finger 47. Although only two feed fingers have been shown in the drawings, it will be understood that additional feed fingers are preferably provided and that means are provided for moving the feed fingers into and out of operative position, so that thread changes may be made as desired.

The lower cylinder is provided with sinkers 50 (Fig. 5) or equivalent instrumentalities disposed between successive needles and adapted to cooperate with the needles in forming stitches. The sinkers are shown as having butts 51 and are acted on by sinker cam 52 to move the sinkers between an inner position shown at the left hand side of Fig. 5 and an outer position shown at the right hand side of said figure.

Instrumentalities cooperating with the needles to form the long terry loops of terry fabric are shown in the drawings as being a series of bits 53 (Fig. 5) associated with the upper cylinder. The

bits 53 are located directly above the sinkers 50 so as to project out between successive needles when the needles are in position to receive thread fed at the feeding station. The relation of the bits to the thread feed is such that the bits project between the terry thread and the body thread so that the terry thread T is fed above the bits, while the body thread B is fed below the bits and between the bits and the sinkers. Where reference is made to feeding one thread above and another thread below the bits or instrumentalities 53 it is not necessary for one thread feed to be located above and the other thread feed to be located below the level of the bits, but only for the threads to be fed in at least slightly separated relation to one another and in such relation to the bits and the needles that one thread is received above the bits and the other below. The needles operating in the lower cylinder are raised high enough to receive both the body thread B and the terry thread T. When the needles are drawn down by the stitch cam, loops of body thread are drawn over the sinkers while loops of the terry thread are drawn over the bits. As the bits 53 are located a substantial distance above the sinkers 50 and as the needle loops of the two threads are drawn together, the loops of terry thread drawn over the bits 53 are much longer than the sinker loops of the body thread drawn over the sinkers 50, for example, approximately twice as long. If desired, the distance between the sinker 50 and bits 53 may be made greater to increase still further the difference in length of the terry loops and the sinker loops of the body thread.

The instrumentalities for forming the terry loops are independently operable and are movable from an inoperative position to an operative position in which the said instrumentalities cooperate with needles in the needle cylinder to produce terry fabric. In the machine shown by way of example in the drawings, the terry bits 53 are illustrated as being moved between an inner retracted position inside the needle circle and an outer or operative position, in which the bits project out beyond the needle circle to separate the terry thread and the body thread and thereby produce terry loops as described above. The bits are moved out as they approach the thread feeding station and are retracted to release the terry loops after loops of the terry thread and body thread have been drawn by the needles. While the bits 53 or equivalent instrumentalities may be supported in any desired manner, they are shown as being carried by a dial 54 mounted adjacent the lower end of the upper cylinder, and hence above the upper end of the lower cylinder. In the arrangement shown, the dial 54 is supported at the lower end of a shaft 55 extending down through the upper cylinder, being held on such shaft by a bushing 56 and screw 57. The dial 54 is rotatable with the cylinder and is provided with a complete circular series of radially extending grooves 58 (Fig. 9) in which the bits 53 are slidable in and out. In order to provide terry loops in each wale of the terry fabric there are as many bits 53 and grooves 58 as there are needles in the needle cylinders, the relative position of the dial and the cylinders being such that the bits 53 are adapted to project out between successive needles. The path of travel of the bits is illustrated in Fig. 9, which shows the bit dial in plan.

As illustrated in Figs. 5 and 9, the bits 53 are projected and retracted by means of butts 60 en-

gaging a cam track in the lower face of a cam 62 located above the dial 54. A plate or washer 59 interposed between the cam 62 and the bit dial 54 engages the inner end portions of the bits to hold the bits in the grooves 58 of the dial. Moreover, the bits are provided with shoulders 61 in front of the butts 60 to steady the bits and assist in keeping them from rising out of the slots or twisting. The bit cam 62 is held against rotary movement by being secured to the vertical shaft 55. The shape of the cam track in the cam 62 is indicated by the path of travel of the butts 60 as illustrated in Fig. 9. As the dial 54 carrying the bits 53 is rotated with the needle cylinders while the cam 62 is held against rotation, the bits 53 are moved in and out by the action of the cam on the butts 60. The cam 62 is positioned in predetermined angular relationship with respect to the thread feeding station to project and retract the bits at the proper time.

When the needle cylinders are turned alternately in opposite directions as in knitting the heel and toe, the relative positions of the points at which the threads are fed and the bits 53 are projected, must be shifted upon reversal of the direction of rotation to assure proper separation of the threads. In the arrangement shown in the drawings this is accomplished by oscillating the bit cam 62 when the machine is operated by reciprocation. At its upper end and above the top plate 63 of the machine, the shaft 55 which carries cam 62 is provided with a pair of arms 64 and 65 (Fig. 3) adapted to engage a buffer block 66. The angular spacing between the arms 64 and 65 permits the shaft 55 and hence the bit cam 62 to oscillate to a predetermined angle, which is preferably adjustable by means of abutment screws 67 and 68. The cam is oscillated within the limits determined by arms 64 and 65 by providing a frictional device between the cam 62 and the needle cylinder, or an element rotating therewith. In the arrangement shown in the drawings this friction device comprises a plurality of plates or washers 69 interposed between the bit dial 54 and the bushing 56, and a plurality of small coil springs 70 set into recesses provided in the upper face of the bushing 56 and pressing upwardly on the washers 69. These spring pressed washers 69 thus provide a frictional drive between the dial 54 which rotates and oscillates with the needle cylinders and the shaft 55 to which the bit cam 62 is secured. Upon reversal of the direction of rotation of the needle cylinders and the dial 54, the shaft 55 and hence the bit cam 62, is carried with the dial by this friction drive until stopped by one of the arms 64 or 65.

In order to produce an article of hosiery of the kind shown in Figs. 11 and 12, it is necessary for the machine to knit a tubular seamless section of non-terry rib knit fabric, an integral section composed of rib knit fabric throughout a portion of its coursewise extent and terry fabric throughout another portion of its coursewise extent, and a third integral section composed throughout of terry fabric. In accordance with the present invention this is accomplished by the individual control of separate groups of the terry bits 53 or other instrumentalities for forming the terry loops of terry fabric. In the arrangement shown by way of example in the drawings, the terry bits of one group are provided with short butts and the terry bits of another group are provided with long butts so that the two groups can be selectively operated. For knitting the

particular article of hosiery shown in Figs. 11 and 12 the terry bits on the sole side of the needle cylinder are provided with long butts, as illustrated at the left hand side of Fig. 5, while the terry bits on the instep side of the needle cylinder are provided with short butts as illustrated at the right hand side of Fig. 5. The circumferential extent of the two groups of bits is indicated in Fig. 9 where the long butts have been shown crosshatched.

The selective operation of individual groups of the terry bits 53 is effected by manipulation of the bit operating cam 62. Instead of moving the whole cam to operate selectively on the different groups of terry bits the cam 62 is shown as being provided with a movable section 71 for moving the terry bits from inoperative to operative position (Figs. 5, 6, 7 and 9). The cam section 71 is movable in a vertical direction. In its uppermost or inoperative position the cam section 71 engages none of the butts of the bits; in its lowermost position the cam engages all of the butts and thereby actuates all of the terry bits (Fig. 7), while in an intermediate position the cam engages only the long butts and hence actuates only one group of the terry bits, namely the bits on the sole side of the needle cylinder (Fig. 6). The mechanism for controlling the vertical position of the movable cam section 71 is shown in Figs. 1, 2, and 5 and comprises a link 72 attached to the cam section and extending up through the top plate of the machine. The link 72 is provided with a flexible joint 73 to permit oscillation of the cam 62 as described above. The upper end of the link 72 is pivotally connected to one end of a rocker arm 74, pivotally mounted at 75 on the top plate of the machine. The other end of rocker arm 74 is connected by a link 76 with a rocker arm 77 actuated by a tappet 78 adapted to engage a cam 80 on the pattern drum 40. The periphery of the pattern cam 80 is stepped in such manner as to provide the three positions of the movable cam section 71 as described above. A coil spring 79 (Fig. 5) tends to move the cam section 71 to its lowermost position. It will be understood that the timing of the pattern drum is such that during the knitting of the top portion 2 and leg portion 3 of the article of hosiery shown in Figs. 11 and 12 the cam section 71 will be in its uppermost position, as shown in Fig. 5, during the knitting of the section of fabric forming the instep portion 4, the high splice portion 5 and sole portion 7, the cam section 71 will be in the intermediate position shown in Fig. 6, and during the knitting of the toe band portion 8 the cam section 71 will be in its lowermost position, as illustrated in Fig. 7.

When needles are operated in the upper cylinder as occurs in knitting rib fabric, there must be provided a knocking over edge which serves the same function as the sinkers in the lower cylinder to engage the previously drawn stitches and cause them to be cast off when new loops are drawn by the needles. The lower edge of the upper cylinder wall ordinarily serves this function and is commonly referred to as a verge. As the terry bits 53 are preferably projected at a level above the lower edge of the verge in order to form long terry loops, the problem arises as to how to prevent interference between the bits and the verge. The problem is complicated by the fact that during the knitting of the leg portion of a sock such as that shown in Fig. 11, the verge must be in operative position through-

out the circumferential extent of the cylinder and during the knitting of the toe band 8, the terry bits must be in operation throughout the circumferential end of the cylinder, while during the knitting of the section of fabric forming the instep portion 4, high splice 5 and sole 7, the terry bits must be in operation on one side of the needle cylinder to form the terry fabric of the high splice and sole, while the verge must be in operative position on the other side of the cylinder to knit the rib fabric of the instep portion. In accordance with the present invention this problem is solved by dividing the verge into a plurality of sections that are individually movable from operative to inoperative position and by controlling the verge sections in coordination with control of separate groups of the terry bits or other terry loop forming instrumentalities, so that the groups of terry bits or instrumentalities are put into operation only when the corresponding verge section is in inoperative position. In the embodiment shown in the accompanying drawings, the verge is divided into two sections, comprising a verge section 84 located on the sole side of the cylinder and corresponding in circumferential extent to the long butt terry bits, and a verge section 85 located on the instep side of the cylinder and corresponding in circumferential extent to the short butt terry bits. Each of these verge sections is movable in a vertical direction between a lower or operative position and a raised or inoperative position, the movement of the two verge sections being individually controlled. As illustrated in Fig. 5, the arcuate verge section 84 having needle grooves corresponding to those of the upper needle cylinder 16, is secured to or integral with the upper needle cylinder, which is rotatable about a bearing sleeve 86 and is supported by a thrust bearing shown as a ball bearing 87, carried by a bearing plate 88. The bearing plate 88 is secured to the lower end of a sleeve 90 which surrounds the vertical shaft 55 carrying the dial 54 and bit cam 62, and extends up through the top plate 63, the upper end of the sleeve 90 being provided with a collar 91. This collar is engaged by the bifurcated end of a lever 92 (Figs. 1 and 3) pivotally supported by a pivot post 93 projecting upwardly from the top plate 63. The other end of the lever 92 is connected through a link 94 to one end of a lever 95 which is pivoted at 96 and has the other end connected through a link 97 with a bellcrank lever 98 which is pivoted at 99 and has a nose portion 100 adapted to engage a cam 101 on the pattern drum 40. When the nose of the bell crank lever rides up on cam 101 the upper needle cylinder 16 and hence the attached verge section 84 on the sole side of the cylinder are raised up out of the way of the bits 53 so that the latter can be projected out to operative position to form terry loops (Fig. 6). A spring 102 acting on link 95 is provided to resiliently oppose the action of cam 101 on bell crank lever 98. It will be understood that this vertical movement of the upper needle cylinder does not affect the length of the stitches drawn, as the stitch length is controlled by the distance the needles are drawn by the stitch cam 33 which of course is not raised with the cylinder. While the vertical position of the bit dial 54 may if desired be adjustable, for example by vertical adjustment of the shaft 55 the dial is not raised by the upward movement of the upper needle cylinder as described above, and hence the verge

section 84 which is attached to the upper needle cylinder is lifted above the level of the terry bits 53 when the upper needle cylinder is raised so that the bits on the sole side of the cylinder can be operated to produce terry loops without interference by the verge.

The other verge section 85 located on the instep side of the cylinder is likewise movable in a vertical direction between a lower or operative position and a raised or inoperative position, the two verge sections being independently controlled. In the embodiment shown in the drawings, the verge section 85 is in the form of an arcuate section having its outer periphery cut to form needle grooves corresponding to the needle grooves of the upper cylinder. The inner periphery of the verge section 85 engages a parti-peripheral flange 103 which projects upwardly from the bit dial 54, the circumferential extent of the verge section 85 and the flange 103 being the same as that of the group of terry bits 53 provided with short butts (see Figs. 5, 9 and 10). As will be seen from Fig. 9, the grooves 58 in the bit dial 54 extend out through or below the flange 103 so that the flange does not interfere with the outward movement of the bits when in operation. A plurality of vertical spaced bars 104 extend upwardly from the verge section 85 inside the upper needle cylinder and fit into correspondingly spaced vertical keyways 105 formed in the outer surface of the flange 103 provided on the dial. As will be seen from Fig. 9, the bars 104 interlock with keyways 105 to prevent the separation of the verge section 85 from the dial in a radial direction, while permitting the relative vertical movement of the verge. The bars 104 are provided at their upper ends with fingers 106 (Figs. 5 and 10) which engage in a peripheral groove 107 formed in a ring or spider 108 which is positioned inside of and concentric with the upper needle cylinder and surrounds the central vertical shaft 55. The spider 108 does not rotate but may if desired be permitted to oscillate with the bit cam 62 during operation of the machine by oscillation of the needle cylinder in order to prevent interference between the bit cam and the spider. One or more risers 109 provided on the spider 108 extend upwardly through openings in the bearing plate 88 and are connected at their upper ends with a collar 110, slidably mounted on a bushing 111 that projects downwardly from the top plate 63 and surrounds the sleeve 90 by which the bearing plate 88 is carried. A ring 112 fitting into a peripheral groove 113 provided in the bushing 111 is connected by a link 114 with an arm 115 provided on a rocker shaft 116 which extends across the top plate 63 of the machine as shown in Fig. 3, and is provided with suitable bearings 117. The outer end of the rock shaft 116 is provided with an arm 118 which is connected by a vertically extending link 119 with a cam follower 120 pivoted at 121 and having a nose portion 122 adapted to engage a cam segment 123 provided on the pattern drum 49 or an auxiliary drum carried on the same shaft. A spring 124 acts downwardly on a link 119 and resiliently opposes upward movement of the link by action of the cam segment 123. When nose 122 of the pivoted cam follower 120 rides up on the cam segment 123 (Fig. 2), the spider 108 inside the needle cylinder is moved vertically upwards from the position shown in Fig. 5, to the position shown in Fig. 7.

As the verge sections 84 and 85 together form a complete circle, it will be seen that the ends of

the verge section 84 carried by the upper needle cylinder about the ends of the verge section 85 and of the flange 103 carried by the dial so that the verge section 85 is carried around with the verge section 84 and the bit dial 54 is thereby made to rotate with the needle cylinder. The split verge thus forms a simple and effective means for driving the bit dial 54 and the independently controlled verge section 85 in synchronism with the needle cylinders, so as to maintain the needle grooves of the verge 85 in alignment with the needle grooves of the cylinder. As the needle cylinder, the bit dial 54 and the two verge sections rotate about the vertical axis of the cylinder, the fingers 106 provided at the upper ends of bars 104 (Figs. 5 and 10) slide around in the peripheral groove 107 of the spider 108, the latter being held against rotation. The spider 108 may however be permitted to oscillate with the bit cam 62 as described above, such oscillations being made possible by the rotatable connection between the collar 110 (Fig. 5) and the ring 112 which fits into groove 113 of the collar. It will be seen that such oscillation has no effect on the verge section 85. However, the vertical position of the verge section 85 is controlled by the vertical position of the spider 108 owing to the engagement of the fingers 106 of the verge section in the annular groove 107 provided in the spider, and the verge section is thus raised and lowered under control of cam segment 123 on the pattern drum acting through cam follower 120, link 119, rocker shaft 116 (Figs. 2 and 3) link 114 (Fig. 5) collar 110 and the risers 109 which connect the collar 110 with the spider 108.

As will be seen from Fig. 9 the circumferential extent of the vertically movable verge section 85 is substantially equal to that of the groups of terry bits 53 having short butts. Likewise the circumferential extent of the verge section 84 carried by the upper needle cylinder is substantially equal to that of the group of terry bits having long butts. The control of the individual verge sections is coordinated with the control of the individual groups of terry bits so that when both verge sections are in their lower or operative positions, none of the terry bits are in operation; when the verge section 84 is in inoperative position and the verge section 85 is in operative position, the group of terry bits having long butts are in operation while the group of bits having short butts remain inoperative, and when both verge sections are in inoperative position all of the terry bits are in operation throughout the circumferential extent of the needle cylinders. It will of course be understood that instead of having only two individually controlled verge sections and two individually controlled groups of terry bits as shown by way of example in the drawings, it may in some instances be desired to employ a greater number of verge sections and a corresponding number of groups of terry bits. It will likewise be understood that in the present specification and claims the term "verge" is used broadly to designate any instrumentality for knocking over the stitches drawn by the upper cylinder needles, and the term "terry bits" is likewise used broadly to designate any instrumentalities cooperating with the needles to form the terry loops of terry fabric.

The operation of the machine will be understood from a brief description of the steps in making an article of hosiery such as that shown in Fig. 11. The socks are preferably produced by string work with a number of ravel courses of plain knit fabric

referred to as a looper's edge between successive socks in the string. Following the looper's edge the welt or anti-ravel edge 1 of the sock and the top portion 2 are produced in any desired manner. Upon completion of the top, the transfer cams 38 and 39 act on selected needles to position certain needles or groups of needles in the upper cylinder, and the remaining needles in the lower cylinder to produce the rib knit fabric of the leg portion 3. While the fabric of the leg portion 3 has been illustrated by way of example in the drawing as being 6x3 rib fabric, it will be understood that any other fabric having either straight vertical ribs or Links-Links patterns may be produced by suitable transfer of selected needles from one cylinder to another. During the knitting of the top portion 2 and leg portion 3, both of the verge sections 84 and 85 are in operative position and all of the terry bits 53 remain inactive. The position of the parts of the machine during the knitting of the leg portion is illustrated in Fig. 5, it being understood however that selected ones of the needles will operate at least at times in the upper needle cylinder.

When the upper edge of the high splice portion 5 is reached, a needle transfer is effected to position all the needles in the lower cylinder on the sole side of the cylinder, while the needles on the instep side continue their operation to produce rib fabric. At approximately the same time the upper cylinder is raised to raise the verge section 84 to inoperative position and the movable section 71 of the bit operating cam 62 is lowered to its intermediate position to put into operation the group of terry bits 53 having long butts, these terry bits being located on the sole side of the needle cylinder. The other verge section 85 remains in operative position and the remaining terry bits remain inoperative. The terry bits that are in operation cooperate with the needles in the lower cylinder to form terry fabric on the sole side of the cylinder, while the needles on the instep side of the cylinder operate to produce rib knit fabric forming a continuation of the rib knit fabric of the leg. By remaining in its operative position the verge section 85 makes it possible to knit rib knit fabric on the instep side of the needle cylinder, while simultaneously producing terry fabric on the opposite side of the cylinder, the verge section 84 having been raised up to avoid interference with the terry bits operating on the latter side of the cylinder. It will thus be understood that part of each course is knit as terry fabric, while the remainder of each course is knit as rib knitting. The positions of the machine parts during the knitting of the section of fabric comprising the high splice portion 5 and the upper part of the instep portion 4 of the article shown in Fig. 11 is illustrated in Fig. 6.

The heel portion 6 of the sock is knit by oscillation of the needle cylinders, the needles on the instep side of the cylinder being rendered inactive by control of the switch cams 31 and 37 (Fig. 4) and the number of needles operating on the sole side of the needle cylinder being varied in usual manner to fashion the heel. The terry bits on the sole side of the needle cylinder, i. e., the bits having long butts remain in operation and the bit cam 62 is oscillated within predetermined limits as described above, so that the operation of the terry bits is properly timed in each direction of rotation of the cylinder. The respective positions of the verge sections remain the same as illustrated in Fig. 6, although the position of verge section 85 is immaterial since the needles

on the instep side of the needle cylinder are not in operation during the knitting of the heel.

When the heel is completed circular knitting is resumed and the switch cams are operated to cause needles on the instep side of the cylinder to resume knitting. The sole 7 and the corresponding portion of the instep 4 are thereupon knit in the same manner as the high splice 5 and the upper portion of the instep 4, as described above.

When the toe band 8 is reached, all the remaining upper cylinder needles are transferred to the lower cylinder. At approximately the same time the verge section 85 carried by the bit dial 54 is raised by raising the spider 108 and the movable section 71 of the bit cam 62 is moved downward to its lowermost position to engage the butts of all of the bits. It will be seen that as both of the verge sections have now been raised to inoperative position the terry bits can come into operation throughout the circumferential extent of the cylinder without interference by the verge. The terry bits will thereupon cooperate with the needles in the lower cylinder to produce a tubular seamless section composed throughout of terry fabric.

The toe, like the heel, is produced by reciprocation of the needle cylinders using only the needles on the sole side of the cylinder and operating the bits on the sole side of the cylinder to produce terry fabric. The needles and bits on the instep side of the cylinder are rendered inoperative by control of the switch cams 31 and 37 and by raising the movable section 71 of the bit cam 62 so that it engages only the bits having long butts. Upon completion of the toe all of the terry bits 53 are retracted so that the machine will produce the plain knit looper's edge referred to above. It will be understood that this is accomplished by raising the movable section 71 of the cam 62 to inoperative position (Fig. 5) whereupon the terry bits are retracted by engagement of the butts with the raceway formed in the fixed portion of cam 62. The path followed by the butts of the terry bits when not engaged by the cam section 71 is indicated by dotted lines 125 at the right hand side of Fig. 9. Before going into the welt of the next sock the verge sections 84 and 85 are both lowered to bring both sections into operative position. The position of one or both of the verge sections is preferably adjustable so that the sections will be at the same level when knitting the top portion 2 and leg portion 3 of the sock.

While the operation of the machine has for the sake of convenience been described with reference to the article of hosiery shown in Fig. 11, it will be understood that the machine is not limited to the production of this particular article. It will be seen that by the independent control of separate verge sections and the coordinated control of corresponding groups of instrumentalities for forming terry fabric, the machine of the present invention can produce a tubular seamless section formed throughout of rib knit fabric, an integral section composed of rib knit fabric throughout a portion of its coursewise extent and terry fabric throughout another portion of its coursewise extent and a further integral section composed throughout its coursewise extent of terry fabric. It will further be understood that in a section of fabric composed partly of rib fabric and partly of terry fabric, the relative coursewise extent of the rib and terry portions may be varied as desired.

What we claim and desire to secure by Letters Patent is:

1. In a circular knitting machine having superposed coaxial cylinders and needles operable in either cylinder, a series of independently operable instrumentalities associated with the upper needle cylinder and movable from an inoperative position to an operative position in which said instrumentalities cooperate with needles in the lower cylinder to produce terry fabric, a plurality of verge sections each of which is movable from an inoperative position to an operative position in which it cooperates with needles in the upper cylinder to produce inwardly facing stitches of rib fabric, means for separately controlling said verge sections, and coordinated means for separately controlling separate groups of said instrumentalities corresponding respectively in circumferential extent to the circumferential extent of each of said verge sections, to put said groups of instrumentalities into operation only when the corresponding verge section is in inoperative position.

2. In a circular knitting machine having superposed coaxial needle cylinders and needles operable in either cylinder, a dial rotatable with the upper needle cylinder, a series of bits carried by said dial and movable from a retracted position to an operative position in which said bits cooperate with needles in the lower cylinder to produce a terry fabric, a plurality of vertically movable verge sections associated with the upper needle cylinder, means for individually raising each of said verge sections and coordinated means for separately controlling separate groups of said bits corresponding in circumferential extent to the circumferential extent of each of said verge sections to move the bits of said groups to operative position only when the corresponding verge section is raised.

3. In a circular knitting machine having superposed coaxial needle cylinders and needles operable in either cylinder, a dial rotatable with the upper needle cylinder, a series of bits carried by said dial and movable from a retracted position to an operative position in which said bits cooperate with the needles to produce terry fabric, means for raising the upper needle cylinder independently of said dial, a verge section carried by said upper cylinder and movable vertically therewith, a second verge section associated with said dial, and means for individually raising said last mentioned verge section.

4. In a circular knitting machine having superposed coaxial needle cylinders and needles operable therein, a dial associated with the upper needle cylinder, a verge cooperating with needles in the upper cylinder to produce inwardly facing stitches of rib knit fabric, said verge being divided into a plurality of arcuate sections, one of said sections being carried by said dial, and another being carried by the upper cylinder, said dial being rotated in synchronism with said upper cylinder by interengagement of said verge sections, and means for individually raising said verge sections relative to said dial.

5. In a circular knitting machine having superposed coaxial needle cylinders and needles operable therein, a dial rotatable with the upper cylinder, a verge section carried by said dial, and means for raising and lowering said verge section relative to said dial.

6. In a circular knitting machine having superposed coaxial needle cylinders and needles operable therein, a dial rotatable with the upper cyl-

inder, a verge section carried by said dial and movable vertically relative thereto, a vertically movable non-rotating ring engaged by said verge section, and means for moving said ring in a vertical direction to raise and lower said verge section.

7. In a circular knitting machine having superposed coaxial needle cylinders and needles operable therein, a verge cooperating with needles in the upper cylinder to form inwardly facing stitches of rib knit fabric, said verge being divided into a plurality of arcuate sections, at least one of which is raisable relative to the upper cylinder and has a portion disposed inside said cylinder, and means for individually raising said sections, including a control member extending down into the upper cylinder and acting on said last mentioned verge section to control its vertical position.

8. In a circular knitting machine having superposed coaxial needle cylinders operable by rotation and by oscillation, and needles operable in said cylinders, a vertical shaft extending coaxially of the upper cylinder, a bushing non-rotatably held on the lower end of said shaft, a dial rotatably supported on said shaft by said bushing and adapted to rotate and oscillate with the needle cylinder, a series of instrumentalities carried by said dial, a cam block non-rotatably mounted on said shaft and adapted to cooperate with said instrumentalities, a spring pressed washer interposed between said bushing and said dial and providing a friction drive for oscillating said bushing, shaft and cam block upon oscillation of said dial, and means for limiting the oscillation of said cam block.

9. In a circular knitting machine having superposed coaxial needle cylinders and needles operable therein, a dial associated with the upper cylinder, a circular series of bits carried by said dial and adapted to cooperate with needles in the lower cylinder to produce terry fabric, said bits having butts of different lengths, a cam for operating said bits by engagement with said butts, said cam being movable between a position in which it engages none of said butts, a position in which it engages some of said butts, and a position in which it engages all of said butts, a verge associated with the upper cylinder and comprising a plurality of sections, each of which is individually movable between a position in which it cooperates with needles in the upper cylinder to produce inwardly facing stitches of rib knit fabric, and a second position in which it is out of the path of movement of said bits, and coordinated control mechanism for controlling the positions of said cam and said verge sections.

10. In a circular knitting machine having superposed coaxial needle cylinders, needles operable therein, and means for transferring needles from one cylinder to the other, a series of independently movable instrumentalities adapted to cooperate with needles in the lower cylinder to produce terry loops of terry fabric, a verge comprising a plurality of sections, each of which is individually movable between a position in which it cooperates with needles in the upper cylinder to produce inwardly facing stitches of rib fabric, and a second position out of the path of movement of said instrumentalities, and pattern controlled mechanism for controlling the movement of said verge sections and the operation of said instrumentalities and needles to produce a tubular seamless section of rib knit fabric, an integral section composed of rib knit fabric throughout a

17

portion of its coursewise extent and of terry fabric throughout the balance of its coursewise extent, and a further integral section composed throughout of terry fabric.

11. In a circular knitting machine having superposed coaxial needle cylinders and needles operable therein, a series of independently movable instrumentalities associated with the upper cylinder and cooperating with the needles to produce terry fabric, a verge comprising a plurality of sections each of which is individually movable between a position in which it cooperates with needles in the upper cylinder to form inwardly facing stitches of rib knit fabric, and a second position out of the path of movement of said instrumentalities, and coordinated means for selectively controlling the individual movement of said sections and the operation of said instru-

5

10

15

18

mentalities in corresponding portions of the circumferential extent of the needle cylinders to operate said instrumentalities only when the corresponding verge section is in said second position.

PAUL L. THURSTON.
HAROLD WELKER.

REFERENCES CITED

The following references are of record in the file of this patent:

UNITED STATES PATENTS

Number	Name	Date
1,910,457	Bentley -----	May 23, 1933
2,085,619	Wainwright -----	June 29, 1937
2,231,399	Thurston -----	Feb. 11, 1941
2,370,449	Clarke -----	Feb. 27, 1945