

(No Model.)

E. L. DUNHAM.

DOOR HANGER.

No. 347,694.

Patented Aug. 17, 1886.

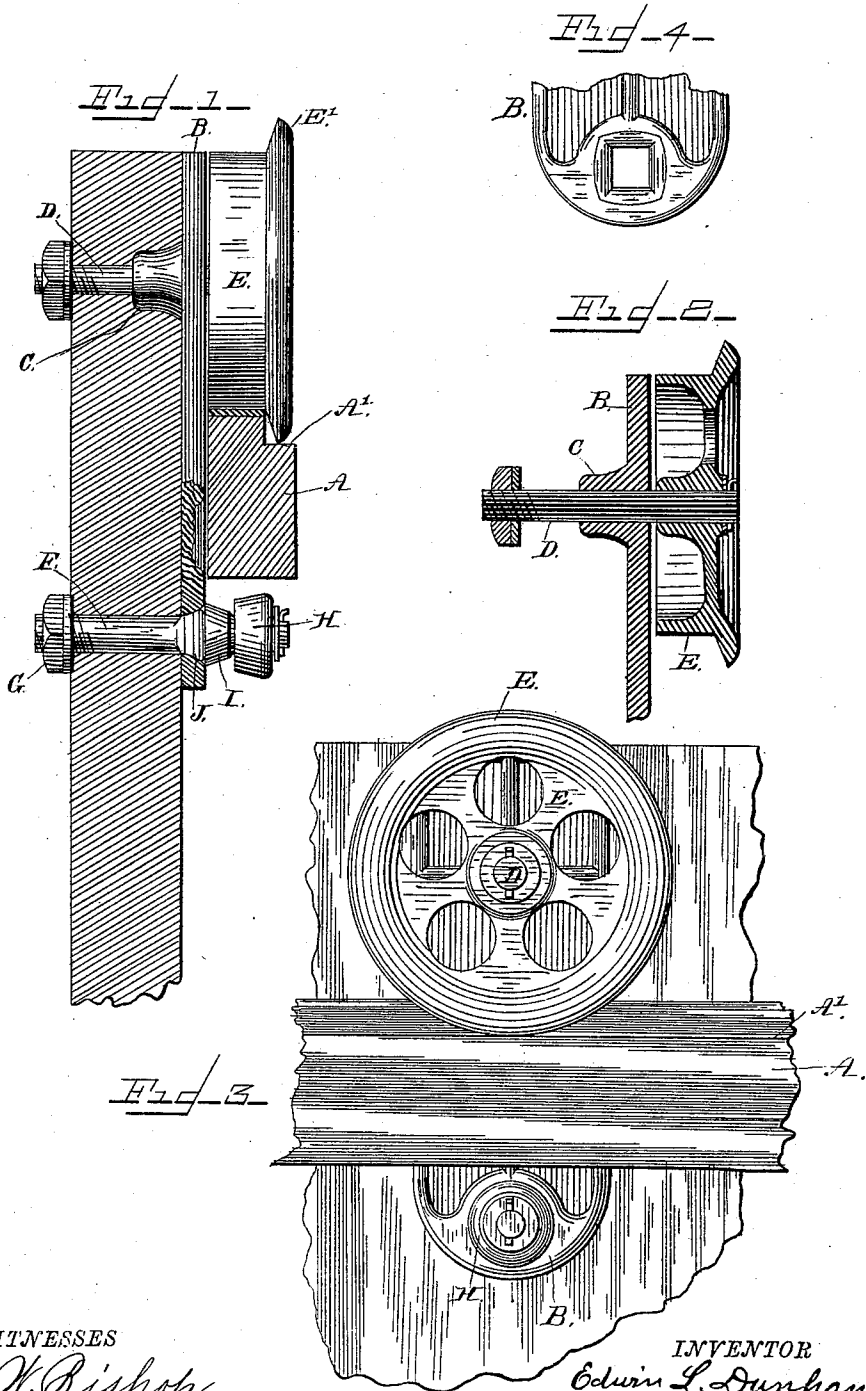

WITNESSES  
*R. W. Bishop.*  
*Pearl Kramer.*

INVENTOR  
*Edwin L. Dunham*  
By *R. S. & A. Lacey*  
Attorneys.

# UNITED STATES PATENT OFFICE.

EDWIN LORENZO DUNHAM, OF QUINCY, MICHIGAN.

## DOOR-HANGER.

SPECIFICATION forming part of Letters Patent No. 347,694, dated August 17, 1886.

Application filed December 16, 1885. Serial No. 185,835. (No model.)

*To all whom it may concern:*

Be it known that I, EDWIN LORENZO DUNHAM, a citizen of the United States, residing at Quincy, in the county of Branch and State of Michigan, have invented certain new and useful Improvements in Door-Hangers; and I do declare the following to be a full, clear, and exact description of the invention, such as will enable others skilled in the art to which it appertains to make and use the same, reference being had to the accompanying drawings, and to the letters and figures of reference marked thereon, which form a part of this specification.

The present invention relates to door and gate hangers, and is intended especially as an improvement on the device for which Letters Patent of the United States, No. 268,645, were issued to me December 5, 1882.

The invention consists in the construction and combination of the parts, hereinafter fully described, and particularly pointed out in the claim.

In the accompanying drawings, Figure 1 is an edge view of my improved door-hanger, the hanger-plate being partly broken away at its lower end, the rail and a portion of the door being shown in section. Fig. 2 is a section of the upper roller and the upper end of the hanger-plate; and Fig. 3 is a front elevation showing the hanger, a section of the rail, and a part of the door. Fig. 4 is a front view of the lower portion of the hanger-plate, showing the angular opening formed therein.

Referring to the drawings, A represents the hanger-rail, which is secured to the wall of the building in any desired manner. It is provided with a ledge, A', for the reception of the flange on the upper roller on the side next the building, as hereinafter described. Its upper side is faced with metal, so as to present a smooth surface for the roller, as well as one which will stand the wear of constant use.

The hanger-plate B is made of cast metal, and near its upper end is provided with a boss, C, cast integrally therewith, through which the axle D of the upper roller, E, is passed. The end of this axle which projects beyond the door is screw-threaded, and a nut and washer placed thereon are used to secure the same by being turned up against the door. The roller E is placed on the opposite end of the axle and revolves thereon. The axle D is secured in

position in the hanger-plate by casting the said plate around the same. In this manner the parts are connected intimately, and a separation is effectually prevented.

The roller E is provided around the inner edge of its circumference with a flange, E', which rests upon the edge of the rail, as hereinbefore referred to. This arrangement prevents the door swinging out of position, as will be readily understood.

Near the lower end of the hanger-plate I provide an angular opening, the sides of which are flared outwardly, as will be understood upon reference to Fig. 1. Through this opening and the door I pass the bolt F, which is screw-threaded on one end, as shown. A nut, G, is placed on this end of the bolt, and secures the door in position by being turned up against the same. The other end of the bolt serves as a journal for the lower roller, H. In order to prevent the bolt F being drawn too far through the opening in the lower end of the hanger-plate, I form a shoulder, I, thereon, just back of the lower roller, H, as shown. I also provide the said bolt with an angular flared portion, J, corresponding to the angular flared opening in the hanger-plate and engaging the same, thereby holding the bolt firm and steady when the nut G is being turned home.

The lower roller, H, has a plain or smooth periphery, and its object is to prevent the door being raised so as to disengage the upper roller from the ledge on the rail, and also to prevent the binding and rubbing usual with hangers using a solid ledge for the same purpose.

In my former patent the bolt or journal which supports the lower sheave or roller had no provision by which it could be prevented from turning while screwing home the nut on its outer end. The present improvement is to provide the lower end of the hanger, through which the bolt passes, with an angular opening having outwardly-flared sides, to receive a correspondingly-shaped shoulder on the bolt, whereby the latter is prevented from turning when the nut is screwed home, said shoulder at the same time serving as a head or point of resistance, between which and the nut the door and plate are clamped.

Having thus described my invention, what

I claim, and desire to secure by Letters Patent,  
is—

5 In a door-hanger, the combination, with the  
door and the hanger-plate having an angular  
opening near its lower end, the sides of which  
are outwardly flared, of a bolt passed through  
the door and the angular flared opening in the  
lower end of the hanger-plate, having a shoul-  
10 der and an angular portion back of the shoul-  
der which engages the angular flared opening

in the hanger-plate, and a roller journaled on  
the outer end of the bolt, all arranged and op-  
erating substantially as and for the purposes  
specified.

In testimony whereof I affix my signature in 15  
presence of two witnesses.

EDWIN LORENZO DUNHAM.

Witnesses:

C. L. TRUESDELL,

C. A. MCKENZIE.