

(No Model.)

2 Sheets—Sheet 1.

# G. L. HART. METAL ROLLING MACHINE.

No. 524,547.

Patented Aug. 14, 1894.

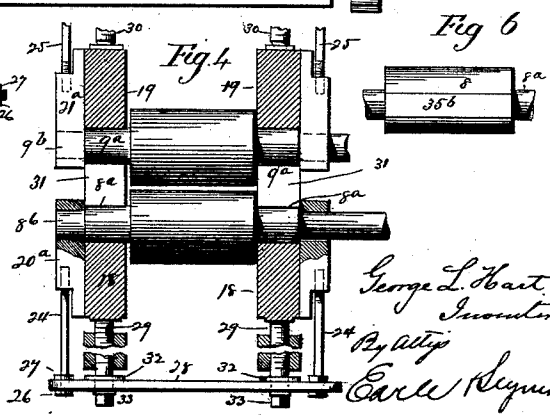
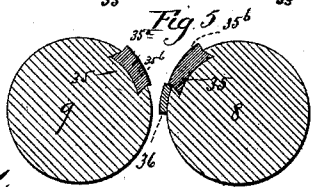
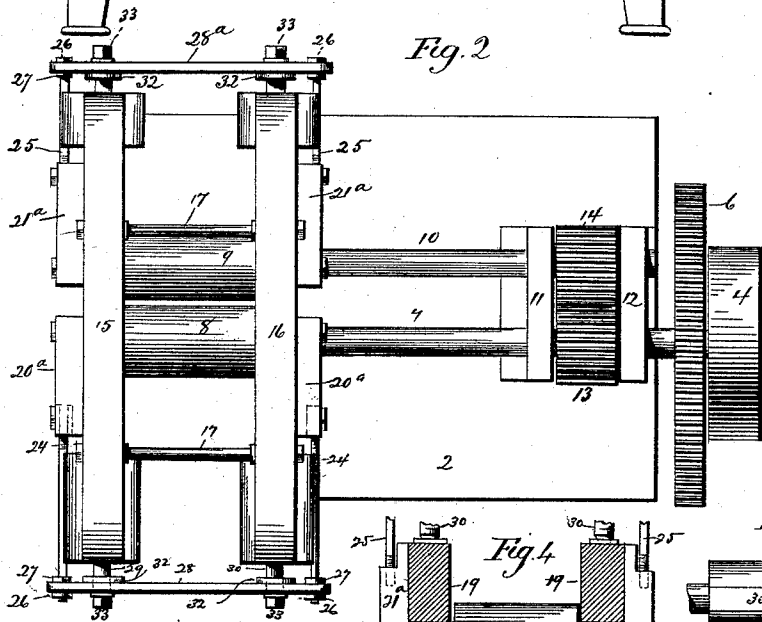
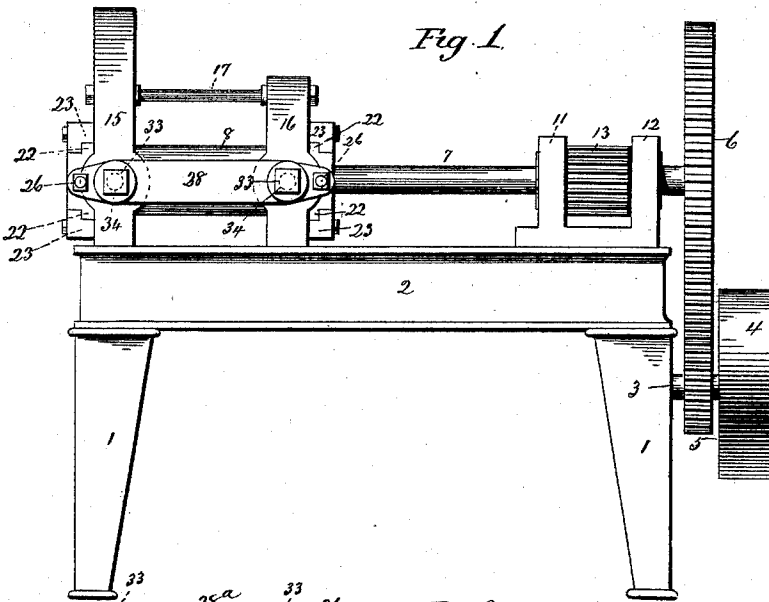

*Witness*  
*J. H. Shumway*  
*Geo. L. Wheeler*

*George L. Hart*  
*Inventor*  
*By Atty*  
*Earl Seymour*

(No Model.)

2 Sheets—Sheet 2.

G. L. HART.  
METAL ROLLING MACHINE.

No. 524,547.

Patented Aug. 14, 1894.

Fig. 3.

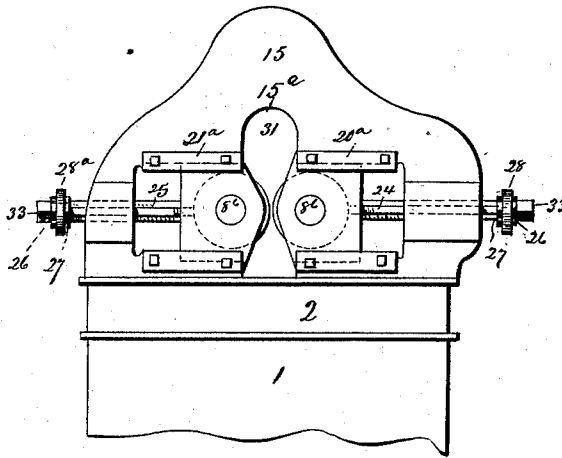
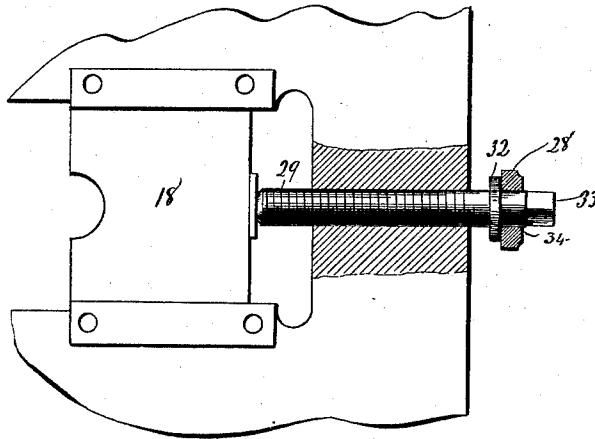

Fig. 3<sup>a</sup>.



Witness  
J. H. Shumway  
Geo. S. Wheelock.

George L. Hart.  
Inventor  
By attys  
Earle Seymour

# UNITED STATES PATENT OFFICE.

GEORGE L. HART, OF UNIONVILLE, CONNECTICUT, ASSIGNOR OF ONE-HALF  
TO HUBERT C. HART, OF SAME PLACE.

## METAL-ROLLING MACHINE.

SPECIFICATION forming part of Letters Patent No. 524,547, dated August 14, 1894.

Application filed July 3, 1893. Serial No. 479,509. (No model.)

*To all whom it may concern:*

Be it known that I, GEORGE L. HART, of Unionville, in the county of Hartford and State of Connecticut, have invented a new Improvement in Metal-Rolling Machines; and I do hereby declare the following, when taken in connection with the accompanying drawings and the figures of reference marked thereon, to be a full, clear, and exact description of the same, and which said drawings constitute part of this specification, and represent, in—

Figure 1, a side view of the machine; Fig. 2, a plan view; Fig. 3, an end view of the machine. Fig. 3<sup>a</sup> is a detail view. Fig. 4 is a sectional view in a horizontal plane, showing how the rolls are adjusted. Fig. 5, is an end view of the pair of rolls. Fig. 6 is a face view of one of the rolls.

My invention relates to metal rolling machines, and more particularly to forming and finishing machines in which knife-blades and other flat ware is rolled. Its object is to produce the taper of flat ware, such as knife-blades and the like, as well as the bevel.

My invention in effectuating this object, consists in a metal-rolling machine having certain details of construction and combinations of parts, as will be hereinafter described and pointed out in the claims.

1 indicates the legs and 2 the bed of the frame on which the parts are mounted.

3 is the power-shaft, 4 a belt-pulley, 5 a gear-wheel on the power-shaft, and 6 is a larger gear-wheel on the drive-shaft 7 of the rolls 8, 9. Roll 8 is mounted on main drive-shaft 7, and roll 9 is mounted on the secondary drive-shaft 10. These two shafts 7 and 10 are parallel, and are journaled in boxes 11, 12, at one end of the frame of the machine. Intermeshing gear-wheels 13, 14, of the same size, are located on and connect shafts 7 and 10 together.

15 and 16 are respectively the outer and inner supports for the pair of rolls 8, 9, between which the latter rotate in a horizontal plane. The support 15 is open, as shown at 15<sup>a</sup>, providing thereby an entrance opening or archway to permit the blanks to be rolled to be inserted edgewise between the rolls from the outer ends thereof. 17 are tie-rods connecting the said supports.

The journals 8<sup>a</sup> 9<sup>a</sup> of the rolls 8, 9 are reduced in size at their extremities, and are received by primary half boxes 18, 19, while their reduced ends 8<sup>b</sup> 9<sup>b</sup> have bearing in their respective secondary boxes 20<sup>a</sup> 21<sup>a</sup>. The secondary boxes 20<sup>a</sup> 21<sup>a</sup> of each roll at their upper and lower edges or flanges 22, are received in guide-ways 23, whereby the said boxes are permitted a to and fro adjustment, effected by means of the two pairs of rods 24, 25, guided in grooves 24<sup>a</sup> in the outer sides of the supports 15, 16. The rods are each provided with a pair of nuts 26, 27, which are screwed onto their outer ends. The nuts 26 fit against the outsides of coupling-bars or plates 28, 28<sup>a</sup>, which connect the outer ends of rods 24, 25, and the nuts 27 constitute jam-nuts which fit against the inner sides of the coupling-bars or plates.

Set-screws 29 and 30 pass through the supports 15 16, and their inner ends bear against the adjustable main or primary boxes 18, 19. These boxes 18, 19 slide in recesses 31, formed in the respective supports 15, 16, and when they are moved in or out, by means of the set-screws 29, 30, place the rolls at the desired angles to each other. As the outer ends of the rolls are always moved more than the inner ends when adjusted, so as to cause a gradually narrowing space between the rolls, the screws 29 must have a greater movement than screws 30, it being required that the thickness of the work be greater near screws 29 than near screws 30.

The rolls 8, 9 are set to their adjusted position by means of the secondary movable boxes 20<sup>a</sup>, 21<sup>a</sup>, which afford bearing for the reduced ends of the journals 8<sup>a</sup>, 9<sup>a</sup>, and which are adapted to force said journals against or into the main half-boxes 18, 19. This setting of rolls 8, 9, is accomplished by means of the nuts 26, 27, on the rods 24, 25, of boxes 20<sup>a</sup>, 21<sup>a</sup>, which are adjusted so as to bring the coupling bars or plates 28, 28<sup>a</sup> against the collars 32 on the set-screws 29, 30, whose heads 33 pass through openings 34 in said coupling bars or plates to permit of their being turned.

Extending longitudinally of each roll is a dove-tail groove 35, into which the dies 35<sup>a</sup> are slid. The faces 35<sup>b</sup> of the dies are formed on a curve tangential to that of the surfaces

of the rolls, so that the bevel to the work may be produced simultaneously with the taper. It is evident that other dies concentric with the rolls may be used, in which case no bevels would be produced. Contiguous to and parallel with the die 35<sup>a</sup> of roll 8, is a shoulder or gage 36, which affords a rest for the work, and onto which the latter may be slipped as the rolls are turning. This shoulder or gage enables a uniform taper to be produced on the work.

I am aware that a metal rolling machine having a roll furnished with adjustable main and secondary boxes is old, and I do not claim that construction broadly.

Having thus described my invention, what I claim is—

1. A metal-rolling machine, provided with a roll, half-boxes in which the said roll has bearing, supports for the said half-boxes, screws for moving the half-boxes inward to move the roll inward, secondary boxes applied to the ends of the roll at points outside of the bearing of the same in the half boxes, guides for the secondary boxes, located upon the outer faces of the supports for the half-boxes, means for positively adjusting the secondary boxes in either direction independently of the screws employed to move the half-boxes inward, and connection between the adjusting-screws of the main boxes and the means for adjusting the secondary boxes, whereby the secondary boxes act to hold the rolls in position in the half-boxes.

2. A metal rolling machine having a roll, adjustable main boxes therefor, supports in which the said main boxes are located, screws

mounted in the said supports and connected with the said boxes for positively adjusting them inward, secondary boxes attached to the journals of the roll, rods connected with the said secondary boxes, a cross-bar connecting the said rods and screws, and nuts located upon the said rods on opposite sides of the cross-bar for positively adjusting the secondary boxes in either direction, substantially as set forth, and whereby the roll may be positively moved inward by the screws of the main boxes, and positively set in any desired adjustment by the secondary boxes and their connections.

3. In a metal rolling machine, the combination with two supports, one of which is cut away for access to the rolls, of two main boxes movably mounted in the said supports, a roll mounted in the said boxes, means for moving the said boxes inward, secondary boxes applied to the projecting ends of the bearings of the roll, and taking into guides located upon the outer faces of the supports, means for adjusting the secondary boxes in either direction to set the roll in its adjusted position, and a longitudinal die and a support mounted in the roll, which is accessible through the opening mentioned, substantially as described.

In testimony whereof I have signed this specification in the presence of two subscribing witnesses.

GEORGE L. HART.

Witnesses:

H. A. COWLES,  
EUGENE C. HEACOX.