

R. WELLS.
CAN-SEALING DEVICE.

No. 173,093.

Patented Feb. 1, 1876.

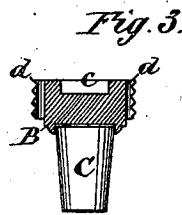
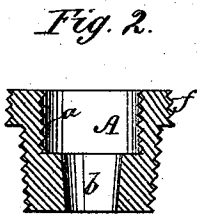
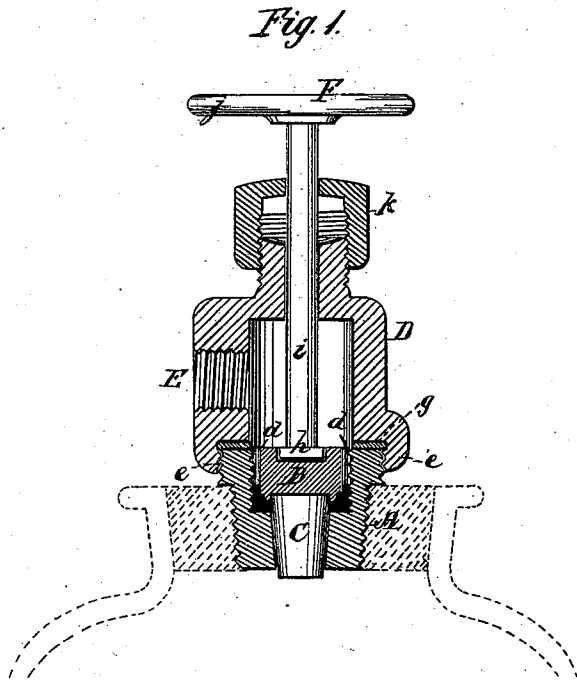

WITNESSES:
John C. Kemou
W. H. Hollingsworth

INVENTOR:
Richard Wells
BY *Wm. V. B.*

ATTORNEYS.

UNITED STATES PATENT OFFICE

RICHARD WELLS, OF BALTIMORE, MARYLAND.

IMPROVEMENT IN CAN-SEALING DEVICES.

Specification forming part of Letters Patent No. **173,093**, dated February 1, 1876; application filed December 27, 1875.

To all whom it may concern:

Be it known that I, RICHARD WELLS, of Baltimore city, State of Maryland, have invented a new and Improved Device for Hermetically Sealing Cans; and I do hereby declare that the following is a full, clear, and exact description of the same, reference being had to the accompanying drawing forming a part of this specification, in which—

Figure 1 is a vertical section. Figs. 2 and 3 are sectional details of the interior and exterior plugs.

This invention relates to certain improvements in that class of devices for sealing cans in which the air is first exhausted by mechanical means, and the can then hermetically sealed. It consists in a plug of metal or other suitable material, screw-threaded, so as to be securely located in the lid or cover of the can. The said plug is hollow, and is also screw-threaded upon its inner surface, into which an interior plug carrying an elastic stopper is screwed. This interior plug is provided with side grooves for the escape of the air, and has a squared recess on its top to receive the end of a wrench or turning-shaft, which passes through a detachable chamber having communication with the exhausting apparatus.

In the drawing, A represents the outer plug, which is screw-threaded and permanently secured into the cork, stopper, cap, or cover of the can, so as to form a part thereof. Said plug may be made of metal, wood, or any other suitable material. It is made hollow, with interior screw-threads at *a*, and a tapering communication, *b*, with the interior of the can, smaller at the bottom than at the top. B is the interior or central plug, which is screw-threaded to mesh with *a*, and has a tapering elastic stopper, C, below, which, when pressed into the tapering hole *b*, seals all communication with the can. The said plug B is provided with side grooves or channels *d* for the escape of the air before it is screwed down, and has also in its top a squared recess, *e*, into which the end of a specially-constructed screw-driver or wrench is inserted to screw in the plug and

press down the stopper. D is a detachable cap, screw-threaded at *e*, so as to mesh with the upper screw-threads *f* of the plug A, and provided with a packing, *g*, so that when it is screwed down upon the plug it forms an airtight chamber. This chamber is provided with a communication, E, for the exhausting apparatus, and has a vertically-moving screw-driver or wrench, F, which consists of a squared end, *h*, shaft *i*, and hand-wheel *j*, the said shaft *i* being arranged to slide vertically in the packing *k*.

The operation of this device is as follows: The plug A being first screwed into the cover or cap of the can, the interior plug B is placed loosely in position, and the detachable cap D is then screwed tightly on. The air from the can is then exhausted by suitable means through the communication E, and as soon as this has been sufficiently accomplished, the wrench F is depressed until its squared end is in the square recess of the plug B. The wrench being then rotated, the plug B is screwed in, and the elastic stopper C is forced into the tapering hole *b*, thus hermetically sealing the can. The cap D is then detached, and the plug left remaining in the top of the can, a separate one being employed for each can.

Instead of having the cap D and its co-operating parts detached, as shown, I may make it a fixture in a frame, and arrange the cans with their plugs beneath the same, so as to apply the cans to the device, instead of applying the device to the cans.

Having thus described my invention, what I claim as new is—

The combination of the outer screw-threaded plug A with the inner screw-threaded plug B, having an elastic stopper, C, channels *d*, and means for turning the same into place, substantially as described.

RICHARD WELLS.

Witnesses:

HENRY M. WARFIELD,
JOHN S. MANLY.