

[54] **PNEUMATIC MUSICAL INSTRUMENT**
 [76] **Inventor: Justin A. Kramer, 1028 W. 8th Pl., Los Angeles, Calif. 90017**
 [22] **Filed: Feb. 14, 1972**
 [21] **Appl. No.: 225,838**

Primary Examiner—Richard B. Wilkinson
Assistant Examiner—John F. Gonzales
Attorney—Vernon D. Beehler et al.

[52] **U.S. Cl. 84/330**
 [51] **Int. Cl. G10d 7/00**
 [58] **Field of Search..... 84/330, 331, 351, 84/375**

[57] **ABSTRACT**

Fixtures are provided for blowing air over the mouths of bottles having the capacity for emitting musical notes of different pitch. Each fixture is provided with a clip-on fastening member capable of being applied to the neck of virtually any standard type of soft drink bottle. An air nozzle has an adjustable mounting on the fastening member so that once the proper position has been established the nozzle can be anchored in position and the fixture will invariably produce the same note as the selected pitch. A hose is connected from the air nozzle to an air supply which may be a keyboard on an air pressure chest or which may be one of a set of individually operated mouth pieces thereby to enable an operator to apply air selectively to the different bottles and in that way to play a tune.

8 Claims, 12 Drawing Figures

[56] **References Cited**

UNITED STATES PATENTS

3,563,127	2/1971	Funakoshi.....	84/330
373,012	11/1887	Chevers	84/330
248,317	10/1881	Hovenden	84/351 UX
128,566	7/1872	Standing	84/330
1,687,086	10/1928	Erb	84/330 UX
2,167,582	7/1939	McCord.....	84/330
2,197,773	4/1940	Rosenfield	84/330
2,353,890	7/1944	Green	84/330

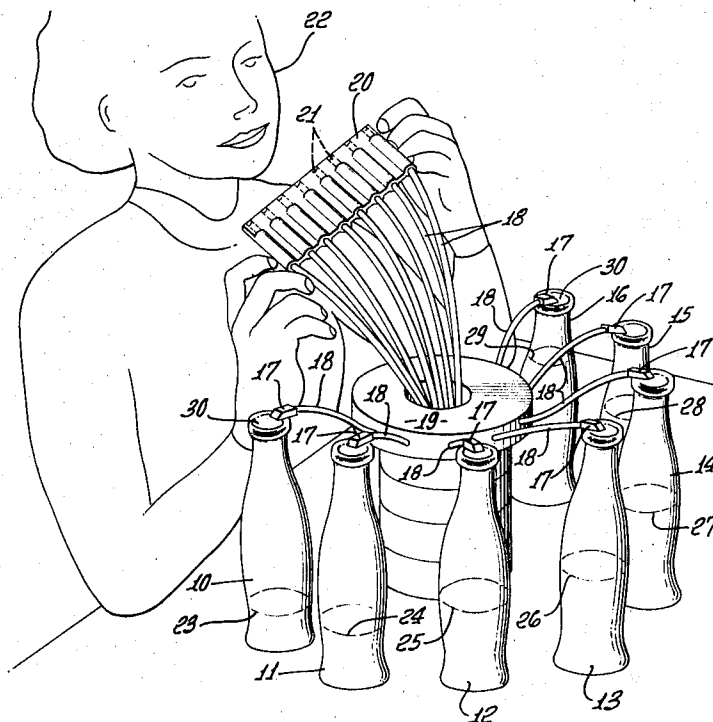

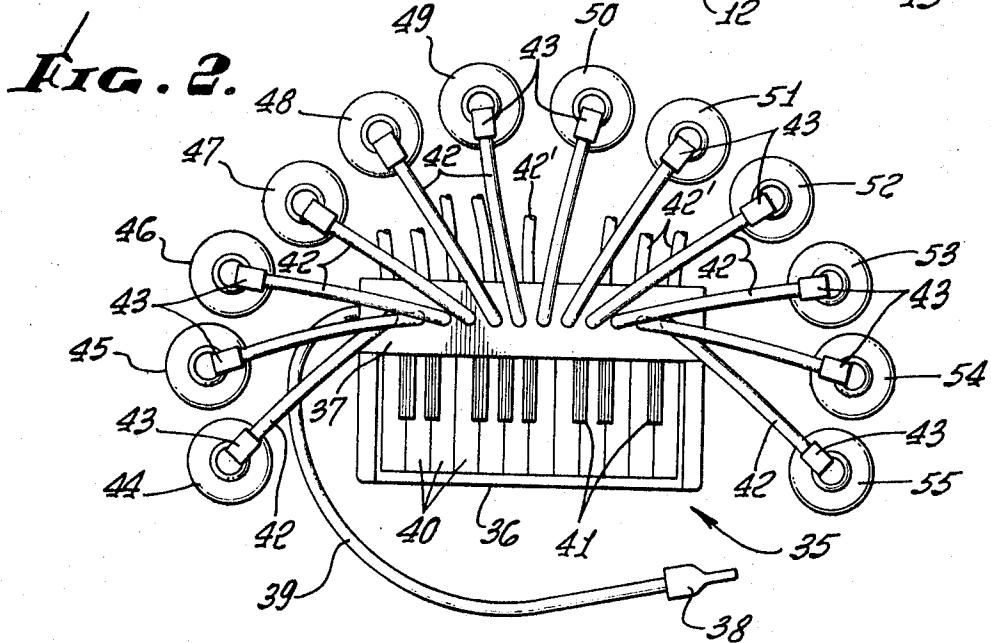
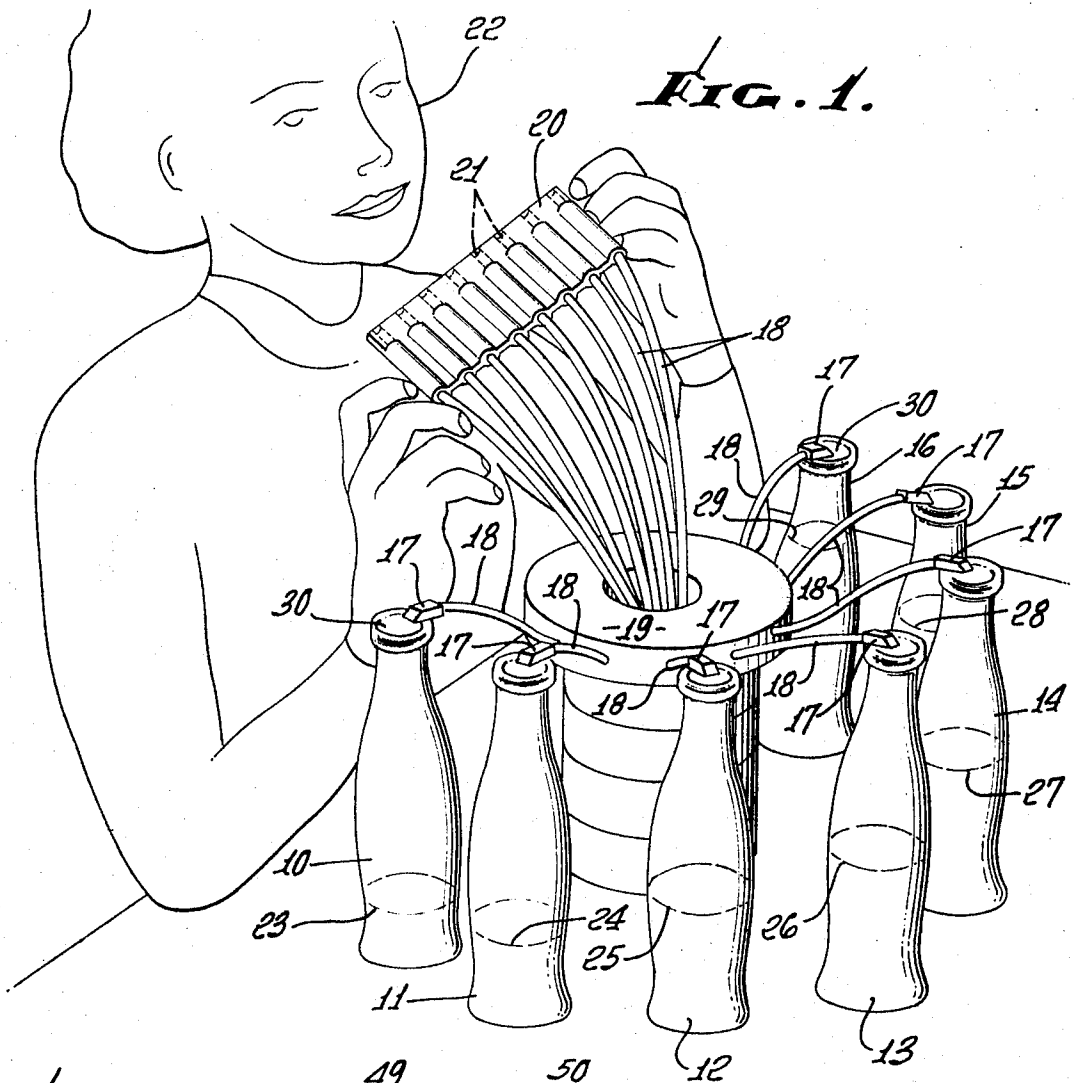

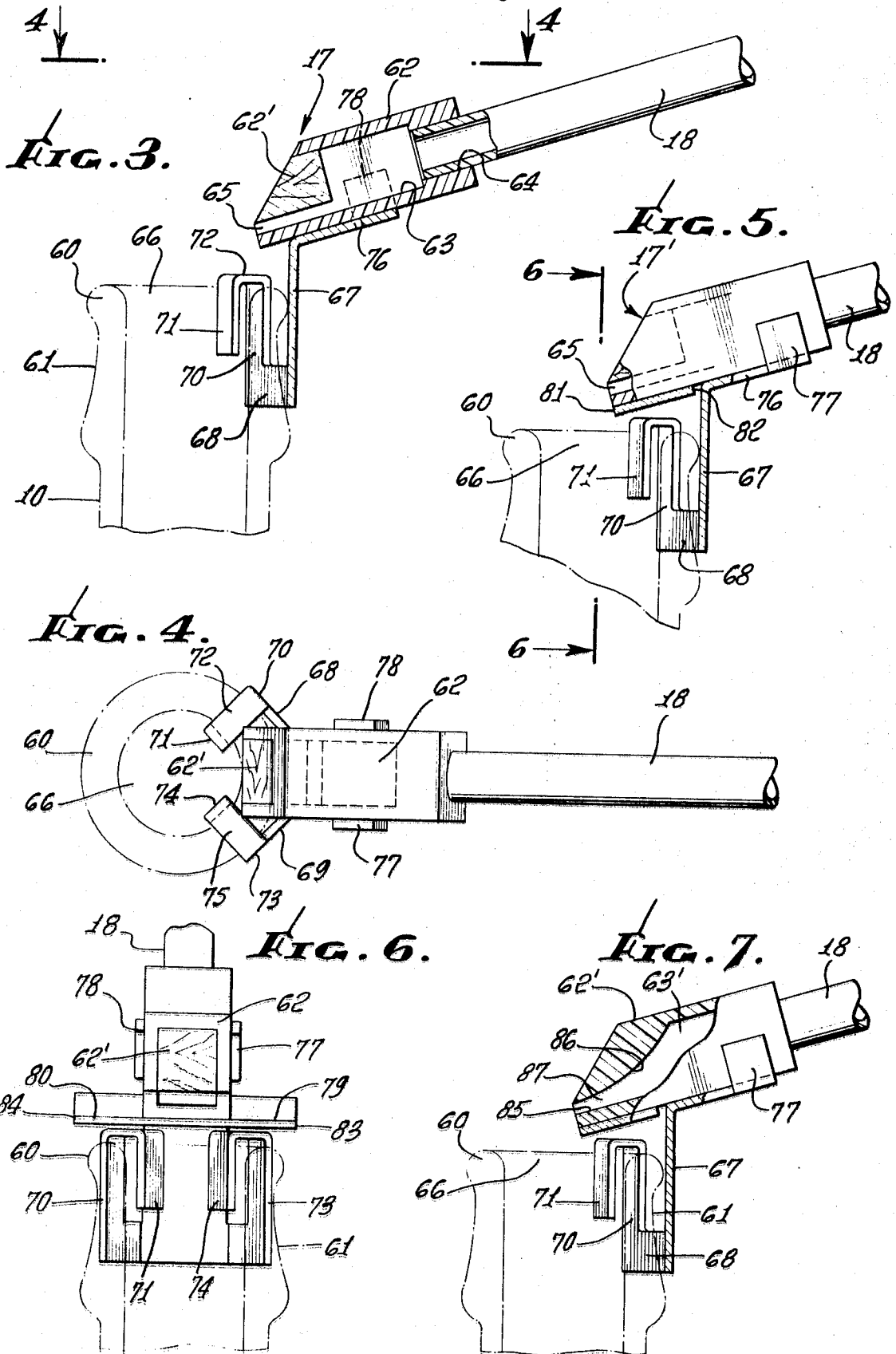

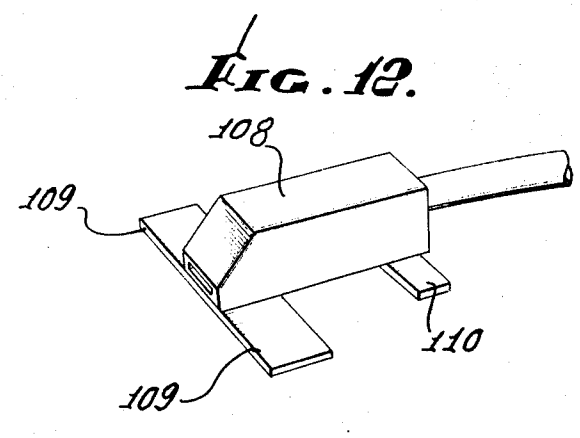
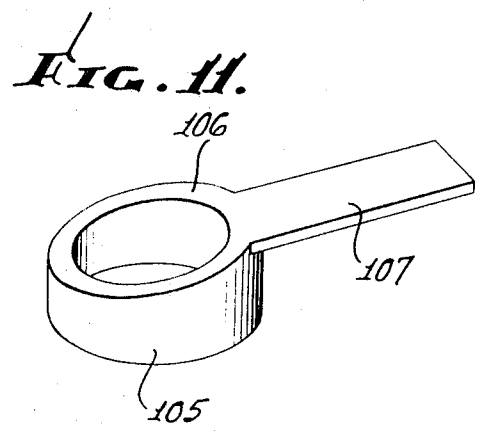
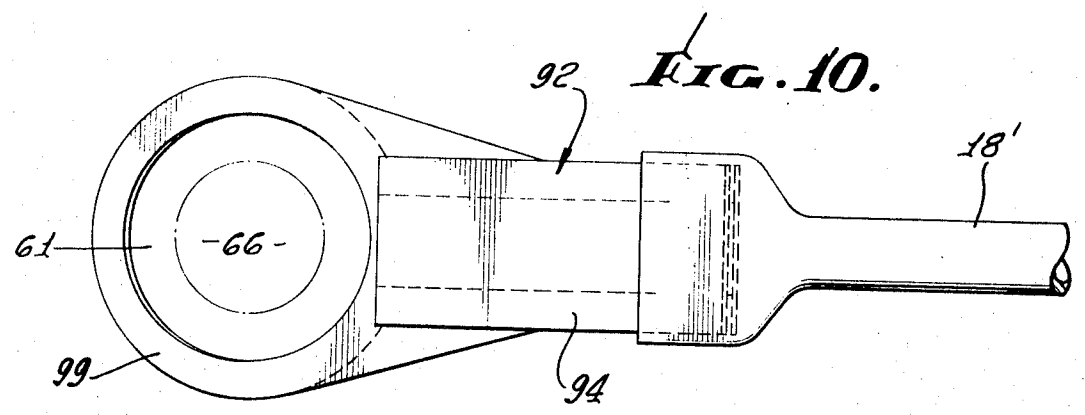
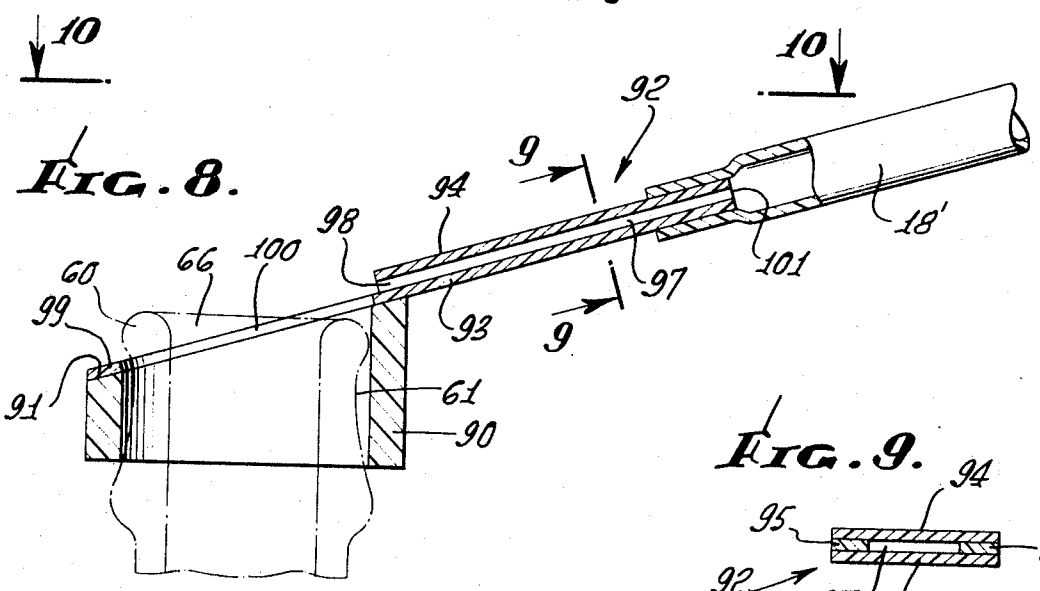

PNEUMATIC MUSICAL INSTRUMENT

Although the invention here under consideration has reference to wind instruments, and makes use of the familiar principle of producing a sound by blowing air over the open end of a standing column of air such as a bottle, the simple expedient of making musical notes at different pitches is insufficient, without appreciable refinement, to produce an acceptable workable musical instrument of very simple adaptability. Moreover when relatively simple devices are undertaken to be made use of by persons of only modest skill, especially by use of what have been familiarly termed "do-it-yourself" kits, such equipment should preferably not be complicated nor present difficult problems of adjustment.

It is therefore among the objects of the invention to provide a new and improved musical instrument which may be made available in the form of a kit which can be set up to play in sequence or simultaneously, a relatively wide variety of musical notes of different pitch which sound agreeable to the listener.

Another object of the invention is to provide a new and improved kit type musical instrument which is simple enough to make use of lung power of the operator, the equipment being sufficiently simple, inexpensive, and positive in operation to permit it to be applied to a series of readily available tone producing objects such as partially filled bottles.

Still another object of the invention is to provide a new and improved air pressure type musical instrument capable of being readily clipped on the neck of a bottle in such fashion that a pure note can be depended upon whether it be of high or low pitch, and wherein such limited adjustment as may be required can be readily and dependably made during assembly in such fashion that once the adjustment has been properly made the same note will always be produced.

Still another object of the invention is to provide a new and improved air pressure type musical instrument which is particularly simple and inexpensive, readily adapted to assembly by persons of modest musical or mechanical ability and which once assembled is capable of producing musical notes of dependable quality and character with the expenditure of very little physical effort on the part of the player.

With these and other objects in view, the invention consists in the construction, arrangement, and combination of the various phases of the method, whereby the objects contemplated are attained, as hereinafter set forth, pointed out in the appended claims and illustrated in the accompanying drawings.

In the drawings:

FIG. 1 is a perspective view of one form of the musical instrument in completely assembled condition.

FIG. 2 is a plan view of another form of the musical instrument assembled in playable condition.

FIG. 3 is a longitudinal sectional view of one of the blower units assembled on the neck of a bottle.

FIG. 4 is a plan view on the line 4 — 4 of FIG. 3.

FIG. 5 is a longitudinal sectional view of the blower equipped for and adjusted for producing a note of relatively high pitch.

FIG. 6 is an end elevational view on the line 6 — 6 of FIG. 5.

FIG. 7 is a side elevational view partially broken away showing an improved form of passage for notes of some specified pitch.

FIG. 8 is a longitudinal sectional view of another form of blower applied to the neck of a bottle.

FIG. 9 is a cross-sectional view on the line 9 — 9 of FIG. 8.

FIG. 10 is a partial plan view on the line 10 — 10 of FIG. 8.

FIG. 11 is a side perspective view of one element of a two piece assembly of another form of the device.

FIG. 12 is a side perspective view of the other element of a two piece form of the device which fits with the piece of FIG. 11.

In an embodiment of the invention chosen for the purpose of illustration there is shown in FIG. 1 a series of bottles 10, 11, 12, 13, 14, 15, and 16 which represent seven different musical notes. On each bottle is a fixture 17 to which is connected a flexible tube 18, all of the tubes being directed into and collected by a housing 19. From the housing the tubes extend to a mouthpiece 20 which can be held in the hands and moved about freely because of the flexibility of the tubes. In the mouthpiece are openings 21 into which a musician 22 can blow, selectively, so as to blow air to any one of the seven different bottles as will be noted. There is a filler in each of the bottles which may be a liquid or semi liquid or even a solid material which establishes bottom surfaces for the bottles at different levels 23, 24, 25, 26, 27, 28, and 29, in this way to vary the distance between what amounts to the bottom of the bottle and an open end 30 where the fixture 17 is attached. The greater the distance the lower will be the note emitted when air is blown into the fixture for that particular bottle, the shorter distances, or in other words higher levels, accounting for notes at higher pitches. Preferably, the material which establishes the various levels is one capable of solidifying or of a non evaporating type after the proper level has been established, so that there will be a non varying pitch for the note emitted from that particular bottle.

In FIG. 2 there is shown a keyboard assembly indicated generally by the reference character 35 contained within a housing 36, on one side of which is a chest 37 for containing air under pressure which is blown into the chest from a mouthpiece 38 through a supply tube 39. The keyboard assembly is provided with a series of white keys 40 and black keys 41 which are arranged in the same general fashion as the keys of a piano or organ and which trip a conventional series of interconnecting valves cooperating in a fashion productive of different notes, and arranged in such fashion that by pressing a combination of different keys simultaneously musical chords can be played.

Fed by air under pressure in the chest 37, through appropriate conventional valving of the type made reference to, are tubes 42, each provided with a fixture 43. The fixtures are attached respectively to containers, here taking the form of bottles numbered 44 and 55 inclusive. In this form of device air is kept under pressure in the chest 37 by blowing through the mouthpiece 38, the air being under a constant uniform pressure so that whenever the keys are manipulated a controlled uniform supply of air is passed through the appropriate tube or tubes 42 to create the musical note or notes. Additional tubes 42' are supplied by the black notes and connected to similar bottles (not shown).

One of the fixtures 17 is shown in detail in FIGS. 3 and 4, attached to a rim 60 on a neck 61 of a bottle. The fixture is embodied in a nozzle element 62 having

a chamber 63 which is in communication through an inlet passage 64 with one of the tubes 18. An outlet orifice 65 is directed over an open end 66 of the bottle adjacent the rim 60, the orifice being formed by a block 62'.

A bracket 67 of for example, bendable sheet metal material has oppositely extending branches 68 and 69. The end of the branch 68 has attached thereto a U shaped element consisting of legs 70 and 71 jointed by a cross piece 72. Similarly, a second U shaped element consisting of legs 73 and 74 are joined by cross piece 75.

An upper extension 76 of the bracket has tabs 77 and 78 which engage the nozzle element 62 by merely being pressed into frictional contact. In this way the nozzle element can be moved to a selected position of adjustment with respect to the rim 60 of the bottle and there anchored in place by being engaged by the wings 77 and 78.

In this form of the device the legs 70, 71 and 73, 74 are readily bendable so that they can be pressed into snug frictional engagement with the neck 61 of the bottle, hung over the rim 60 as shown in FIG. 3, there to set the position of the nozzle 17 with respect to both distance above the rim 60 and distance away from the rim laterally. The relationship shown in FIGS. 3 and 4 is adequate for most of the notes in the lower register. For a few notes in the higher register an additional element should be added to the fixture as exemplified by the fixture 17' of FIGS. 5 and 6. Wings 79 and 80 extend laterally outwardly beyond the outermost edge of the rim 60 and may be positioned slightly above the rim as shown in FIG. 5 or closer to the rim as the occasion may require. The wings have appreciable breadth so that although a front edge 81 can be adjusted to overlie the open end 66 at or close to the mid-line a rear edge 82 projects to a position clear of the open end. In a lateral direction side edges 83 and 84 protrude outwardly beyond the rim 60 by an appreciable margin. It has been found that these wings are very instrumental in making a pure tone of notes in the higher pitch by presumably preventing a column of air to be drawn upwardly around the outside of the neck of the bottle to impair the smooth passage of air under pressure from the outlet orifice 65 over the open end which produces the musical note.

In the form of device of FIG. 7 a nozzle element 62' provided with a chamber 63' makes use of one relatively flat wall 85 and one relatively curved wall 86 to produce an outlet passage 87 of progressively diminishing vertical dimensions and therefore progressively diminishing cross section area between the chamber 63' and the outlet orifice 88. All forms of the invention could be made with a comparable form of outlet passage.

In the form of device of FIGS. 8, 9 and 10 there is provided a resilient collar 90 having an oblique upper surface 91, which for convenience is made annular, the resilient collar being adapted to be stretched over the neck 61 of the bottle. To the oblique surface 91 is secured a nozzle element 92 which consists of lower plate 93 and upper plate 94 held apart in spaced relation by spacers 95 and 96 forming a passage 97 terminating in outlet orifice 98. The lower plate 93 has an enlarged section 99 in which is an opening 100 overlying the open end 66 of the bottle. The enlarged section is attached to the oblique upper surface 91 by an appropri-

ate adhesive or other acceptable means to make an integral unit or if preferred the parts could be molded as a single piece. A tube 18' attached to the nozzle element 92 adjacent an inlet end 101 of the passage 97 supplies air under pressure which is directed over the open end of the bottle by the outlet orifice 98. By employment of a collar like the collar 90 air is prevented from being drawn upwardly around the outside of the neck of the bottle, construction being such that it is sufficiently versatile to accommodate notes throughout all of the desired range. Although the orifice 98 is shown at a location best suited to low notes, this form of the device can be constructed to locate the orifice further toward the left at a location over the open end of the bottle and better suited for high notes. It should be understood that the form of device of FIG. 8 can be modified as disclosed in FIG. 3 to make location of the orifice 98 variable with respect to the opening of the bottle.

FIGS. 11 and 12 show a two piece embodiment of the invention as providing a simple and practical means of fabricating and assembling a fixture. In this form there is provided a resilient collar 105 having an oblique upper surface 106 similar to that described in connection with FIGS. 8, 9, and 10. The collar being adapted to fit frictionally over the neck of a bottle. Extending from the collar 105 is a stiff tab 107 set at an appropriate angle. A nozzle element 108 is provided with deflectors 109 and also with crimping fingers 110. The fingers can be folded around the tab 107 thereby to anchor the nozzle element in a selected position on the tab 107 after the position has been selected as one where air from an outlet orifice 111 produces the clearest note it is capable of producing for one of the bottles, filled as previously described to a level which will produce a note of desired pitch.

It is contemplated as indicated that the various pieces which make up the musical instrument as herein above described can be prepared in kit form independently of bottles, or in fact any other type of elongated container with which such fixtures can be used to produce musical notes. Naturally, bottles such as soft drink bottles or in fact any bottles which make use of crown caps are preferable since they can be secured in a variety of sizes for notes of different timber and volume as well as different pitch. For such use the fixtures can be identical and can be supplied in virtually any number covering one octave for example or as much more than an octave as may be desirable. The fixtures are applied as described and the nozzle elements set initially and there anchored so that once the adjustment has been made the device can continue to be played as a dependable musical instrument. Naturally also since the fixtures are merely clipped in position they can be just as readily removed for reuse on containers or bottles of some other character.

Several varieties of fixtures incorporating different types of nozzle elements have been included as evidence of the fact that the simplified nozzle construction is such that it can be supplied by materials of different kinds which nevertheless follow the dominant principle of easily applied and adjustable nozzles which once the adjustment has been determined are capable of producing a pleasant and agreeable musical note at a true pitch. Since the aim of the instrument is to play tunes the source of air for the several nozzles must be such that the operator can very readily at one central point

control the direction of air passage thereby to operate the device as a musical instrument.

Having described the invention, what is claimed as new in support of Letters Patent is:

1. A musical instrument for employment of small open mouth containers having varied capacity for emitting musical notes of selected pitch, wherein the mouths of said containers are of substantially the same diameter

said instrument comprising a plurality of air directing fixtures of substantially identical construction having an air conducting tube attached thereto, each fixture comprising a fastening member adapted for mounting on the container and over the open mouth thereof, and with the fastening member engaging the exterior of the container leaving the rim of the open mouth exposed,

a nozzle element having a passage therethrough with an outlet end and an inlet end, with the long axis extending therebetween, said fixture having adjacent the nozzle a deflector means at a location adjacent said outlet end in a position blocking travel of ambient air across the path of air from said outlet end,

said tube having a connection at one end to the nozzle element at the inlet end, said long axis being in continuous clear alignment with the exposed edge of said open mouth on the side opposite said nozzle element,

an adjustable connection between the nozzle element and the fixture enabling change in position of said outlet end relative to said edge, and a note selecting unit for said tubes,

said tubes having a connection to said note selecting unit and means selectively admitting air under constant pressure to said tubes whereby to pass air selectively to said tubes and produce notes in selected musical sequence.

2. A musical instrument as in claim 1 including means for anchoring said nozzle member on said fastening member at a selected position of adjustment.

3. A musical instrument as in claim 1 wherein the containers are bottles of selected size and there is a rim on each bottle neck for attachment of a cap, and wherein there is a filler in each bottle for varying the pitch of the note created by each bottle.

4. A musical instrument as in claim 1 wherein the adjustable connection comprises fingers of bendable material adapted to be bent in conformity with the open end of the container.

5. A musical instrument as in claim 4 wherein the adjustable connection is a resilient collar having a friction fit on the neck of the bottle.

6. A musical instrument as in claim 1 wherein the outlet end of the passage through the nozzle is much wider than it is high whereby to provide a relatively flat outlet end and wherein the deflector means comprises relatively flat wide wings which overlie the rim of the bottle and extend radially outwardly beyond the edges of the rim for diverting away air drawn toward the rim on the outside of the bottle.

7. A musical instrument as in claim 1 wherein there is a housing receptive of all said tubes and said tubes have a fixed position in said housing, said tubes being equal in number to the number of said fixtures and wherein there is a separate tube from each fixture extending through said housing to a selected orifice in said note selecting unit.

8. A musical instrument as in claim 1 wherein there is a sound chest for air under constant pressure, valves and said note selecting unit is a key board connected to said chest and wherein said tubes from the fixtures are each in communication with said chest and one only of the keys on said key board.

* * * * *

40

45

50

55

60

65