



US005680841A

# United States Patent [19]

[11] Patent Number: **5,680,841**

Hu

[45] Date of Patent: **\*Oct. 28, 1997**

[54] **INTERNAL COMBUSTION ENGINES WITH COMBINED CAM AND ELECTRO-HYDRAULIC ENGINE VALVE CONTROL**

[75] Inventor: **Haoran Hu**, Farmington, Conn.

[73] Assignee: **Diesel Engine Retarders, Inc.**, Wilmington, Del.

[\*] Notice: The term of this patent shall not extend beyond the expiration date of Pat. No. 5,537,976.

[21] Appl. No.: **772,781**

[22] Filed: **Dec. 24, 1996**

### Related U.S. Application Data

[63] Continuation of Ser. No. 512,528, Aug. 8, 1995, abandoned.

[51] Int. Cl.<sup>6</sup> ..... **F01L 13/06**

[52] U.S. Cl. .... **123/322; 123/321; 123/90.12; 123/90.16**

[58] Field of Search ..... 123/21, 90.11, 123/90.12, 90.13, 90.15, 90.16, 90.17, 320, 321, 322

### References Cited

#### U.S. PATENT DOCUMENTS

3,220,392	11/1965	Cummins	123/97
3,367,312	2/1968	Jonsson	123/97
3,786,792	1/1974	Pelizzoni et al.	123/321
3,809,033	5/1974	Cartledge	123/90.46
4,572,114	2/1986	Sickler	123/21
4,664,070	5/1987	Meistrick et al.	123/21
4,696,265	9/1987	Nohira	123/90.16
5,086,738	2/1992	Kubis et al.	123/322

5,113,812	5/1992	Rembold et al.	123/90.12
5,127,375	7/1992	Bowman et al.	123/90.12
5,146,890	9/1992	Gobert et al.	123/321
5,152,258	10/1992	D'Alfonso	123/90.12
5,255,641	10/1993	Schechter	123/90.11
5,325,825	7/1994	Schmidt et al.	123/90.39
5,379,737	1/1995	Hu	123/322
5,404,851	4/1995	Neitz et al.	123/321
5,537,976	7/1996	Hu	123/322

### FOREIGN PATENT DOCUMENTS

593908 A1	4/1994	European Pat. Off.
653557 A2	5/1995	European Pat. Off.
150705	1/1932	Switzerland
WO 90/09514	8/1990	WIPO
WO 93/25803	12/1993	WIPO

Primary Examiner—Weilun Lo

Attorney, Agent, or Firm—Fish & Neave; Robert R. Jackson

### [57] ABSTRACT

An internal combustion engine has electrically controlled hydraulic linkages between engine cams and engine cylinder valves. If it is desired to skip a cam lobe or to modify the response of an engine cylinder valve to a cam lobe, hydraulic fluid is selectively released from the associated hydraulic linkage to permit lost motion between the cam and the engine cylinder valve. Electrically controlled hydraulic fluid valves are used to produce the selective release of hydraulic fluid from the hydraulic linkages. The mode of operation of the engine can be changed (e.g., from positive power mode to compression release engine braking mode or vice versa), or more subtle changes can be made to modify the timing and/or extent of engine cylinder valve openings to optimize engine performance for various engine or vehicle operating conditions (e.g., different engine or vehicle speeds).

**38 Claims, 8 Drawing Sheets**

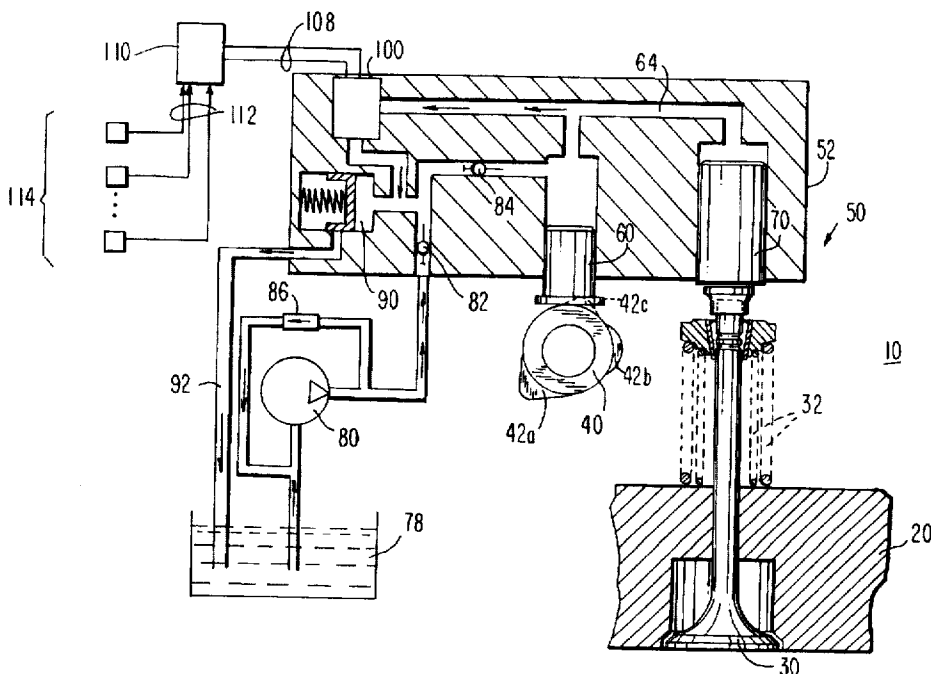
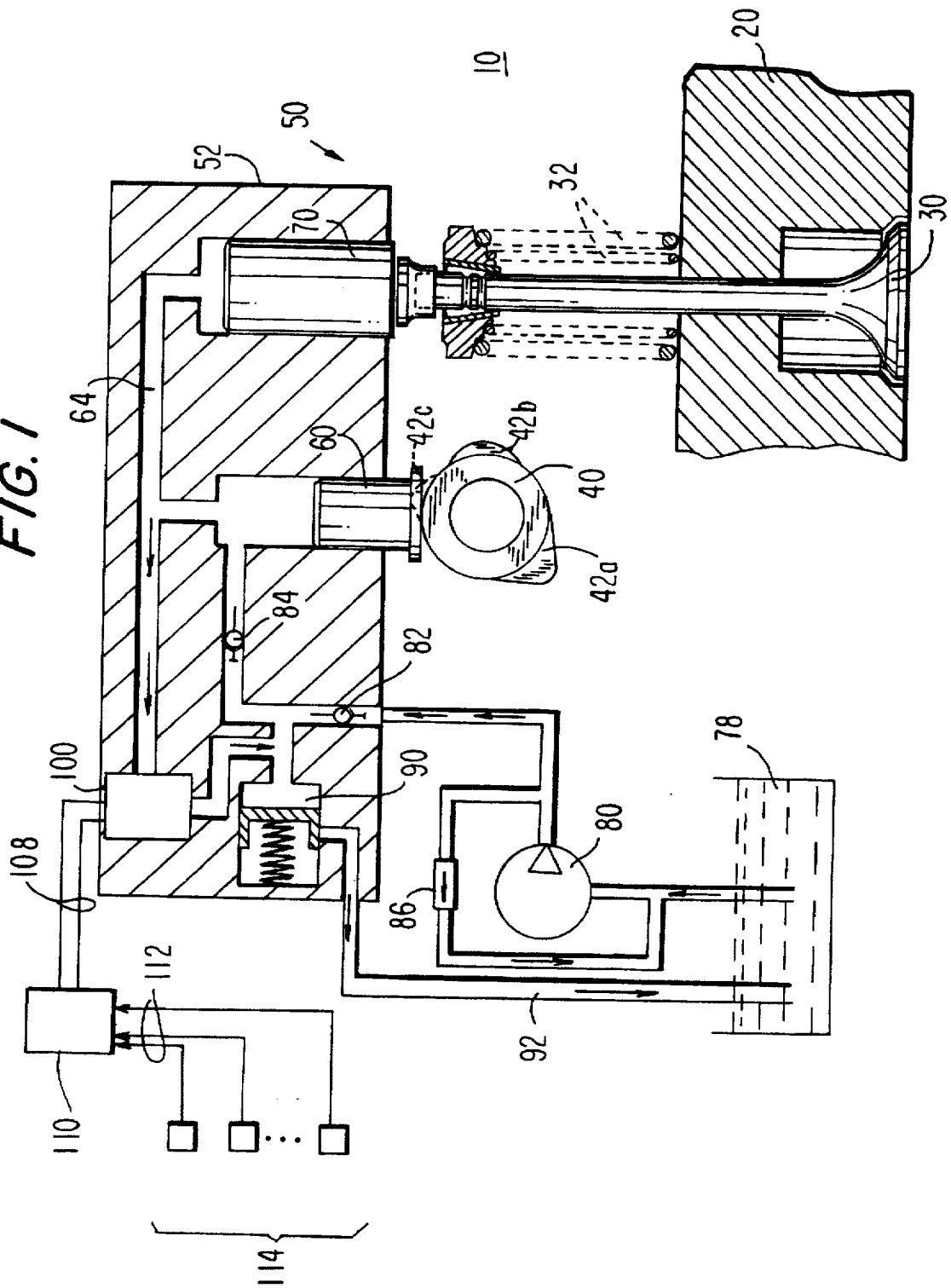

FIG. 1



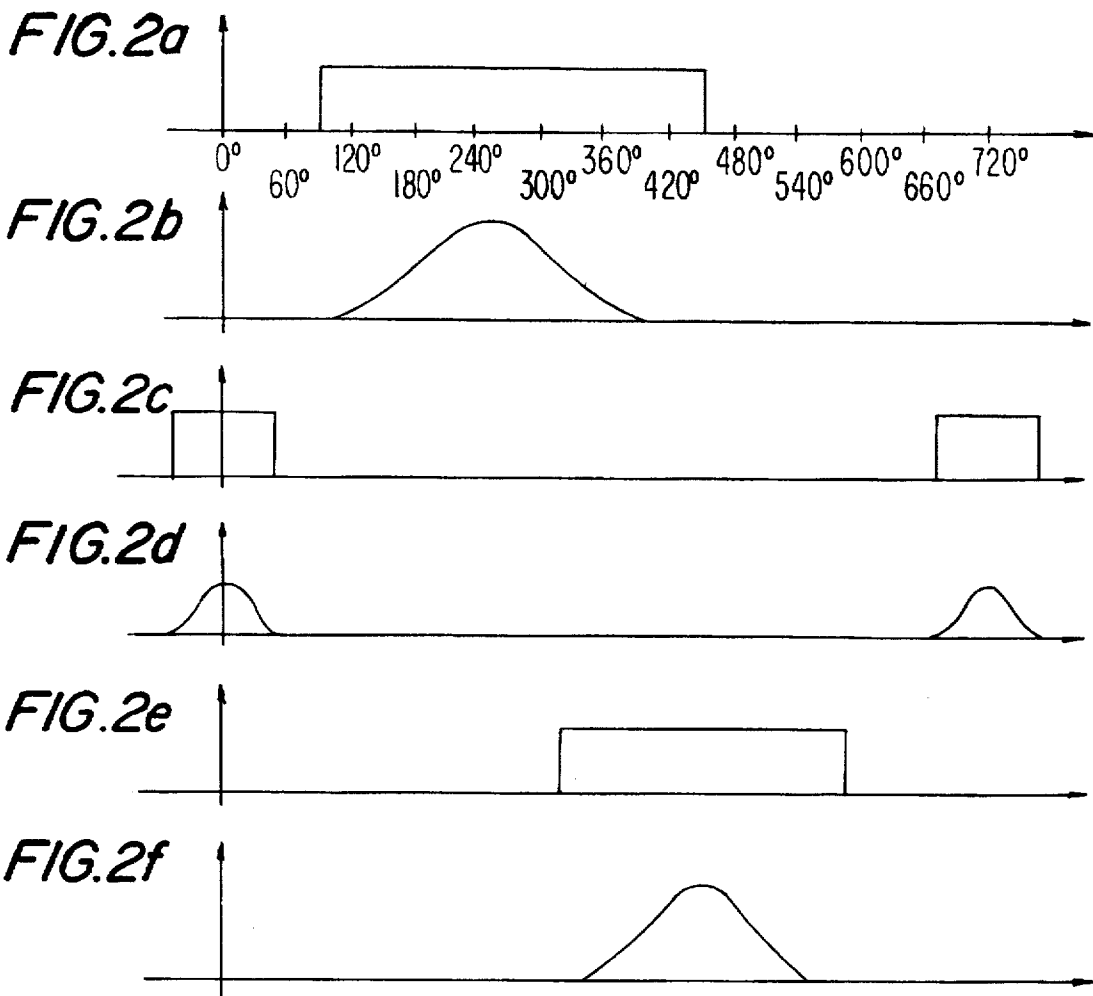

FIG. 3a

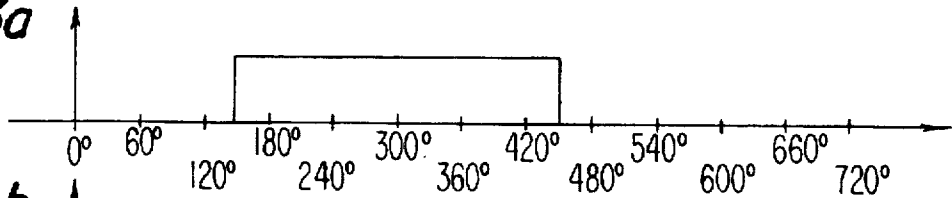

FIG. 3b

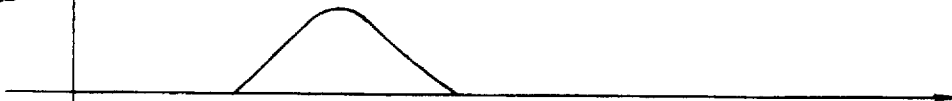

FIG. 4a

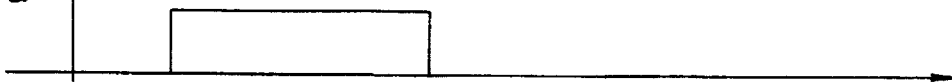

FIG. 4b

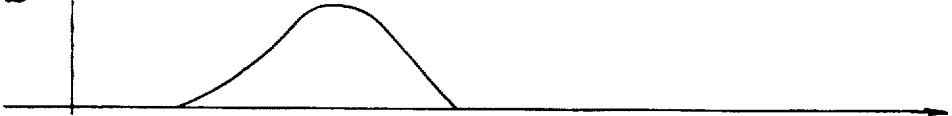

FIG. 5a

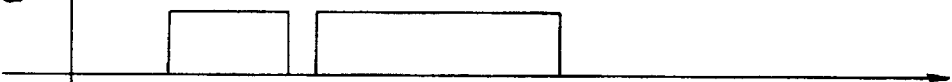
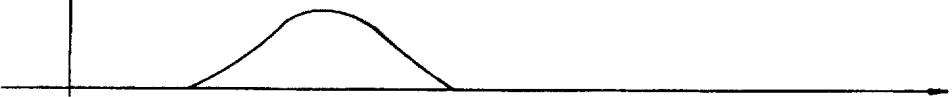

FIG. 5b



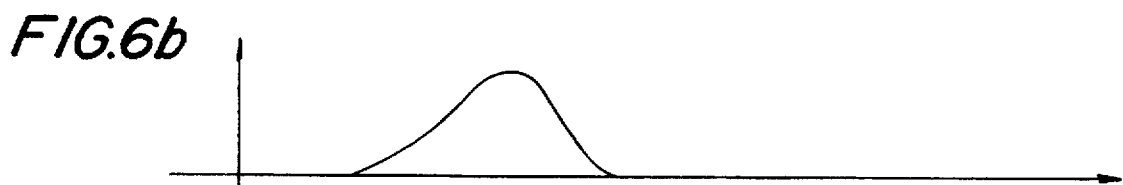
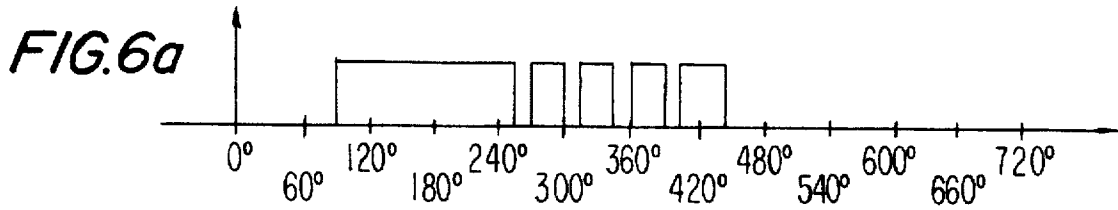

FIG.7a

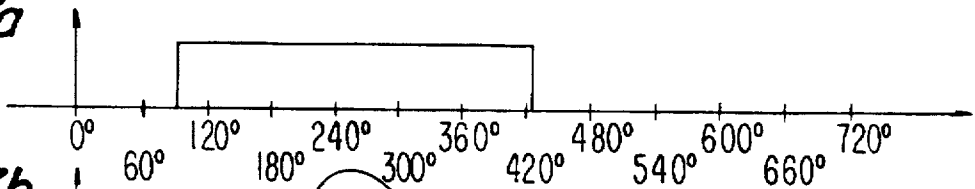

FIG.7b

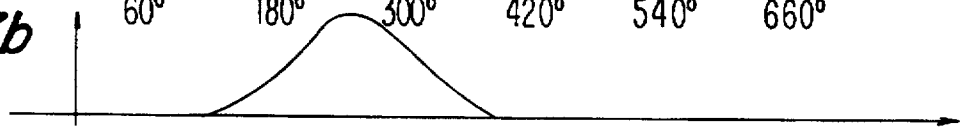

FIG.7c

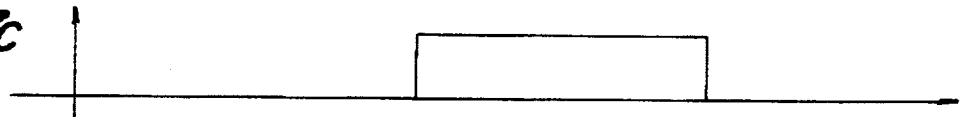

FIG.7d



FIG.7e



FIG.7f



FIG.7g

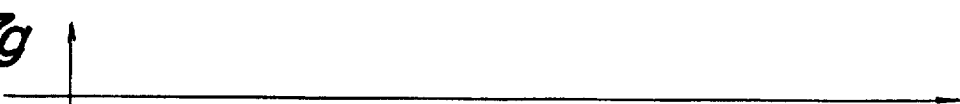
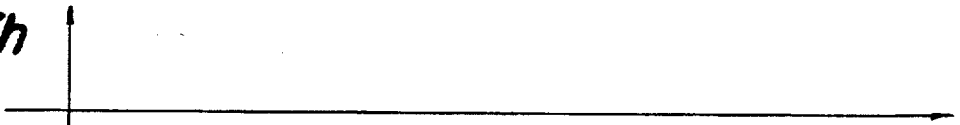

FIG.7h



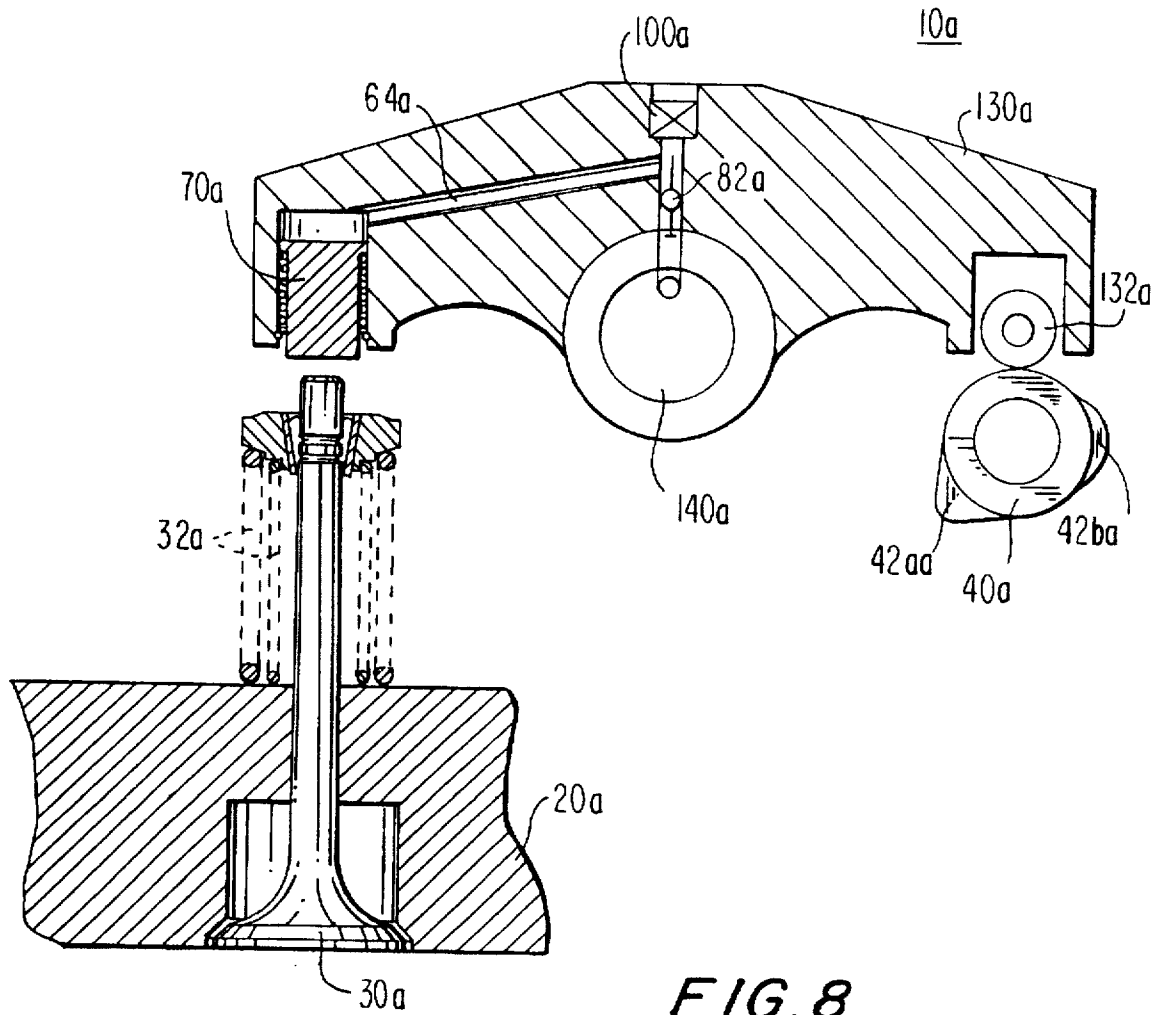

FIG. 8

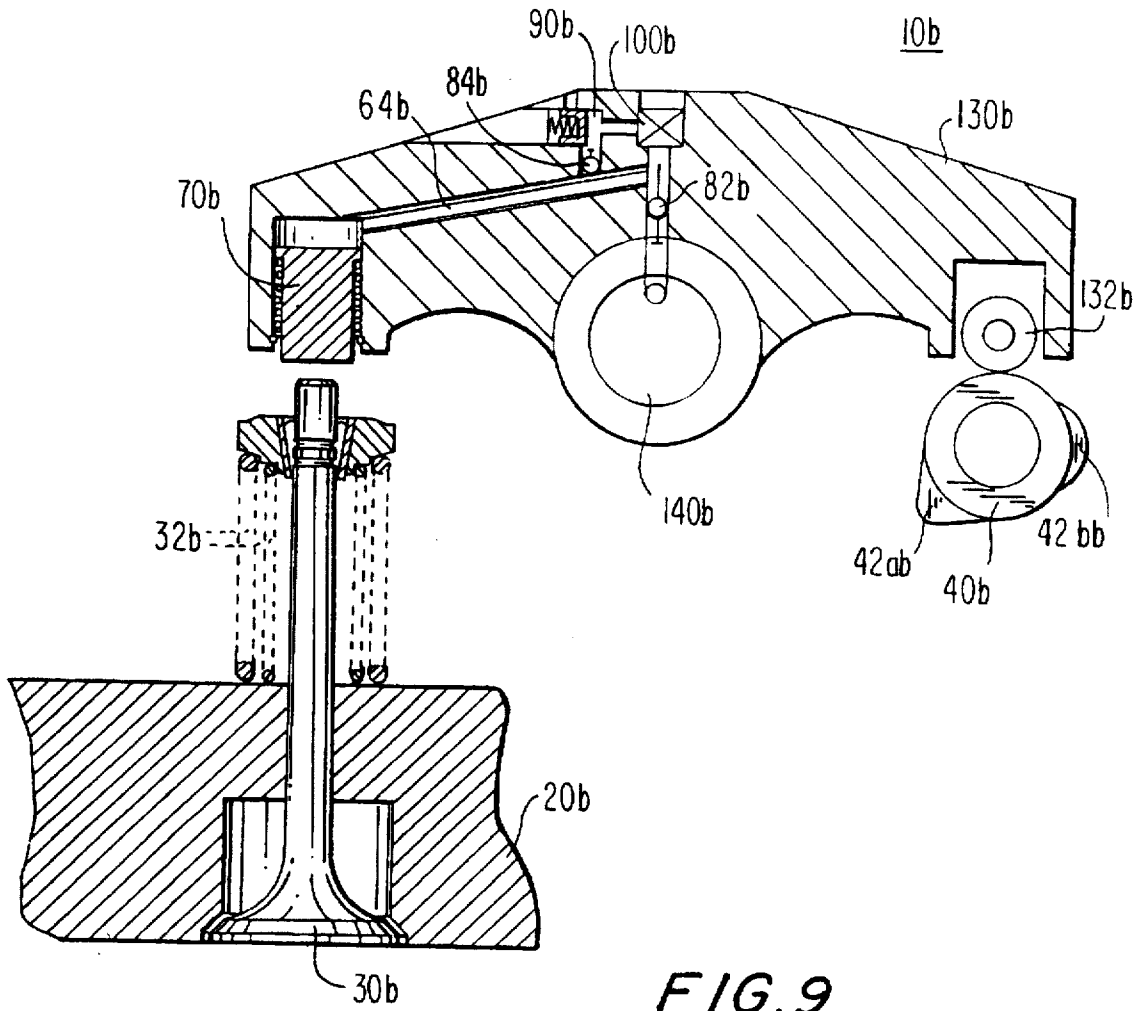

FIG. 9

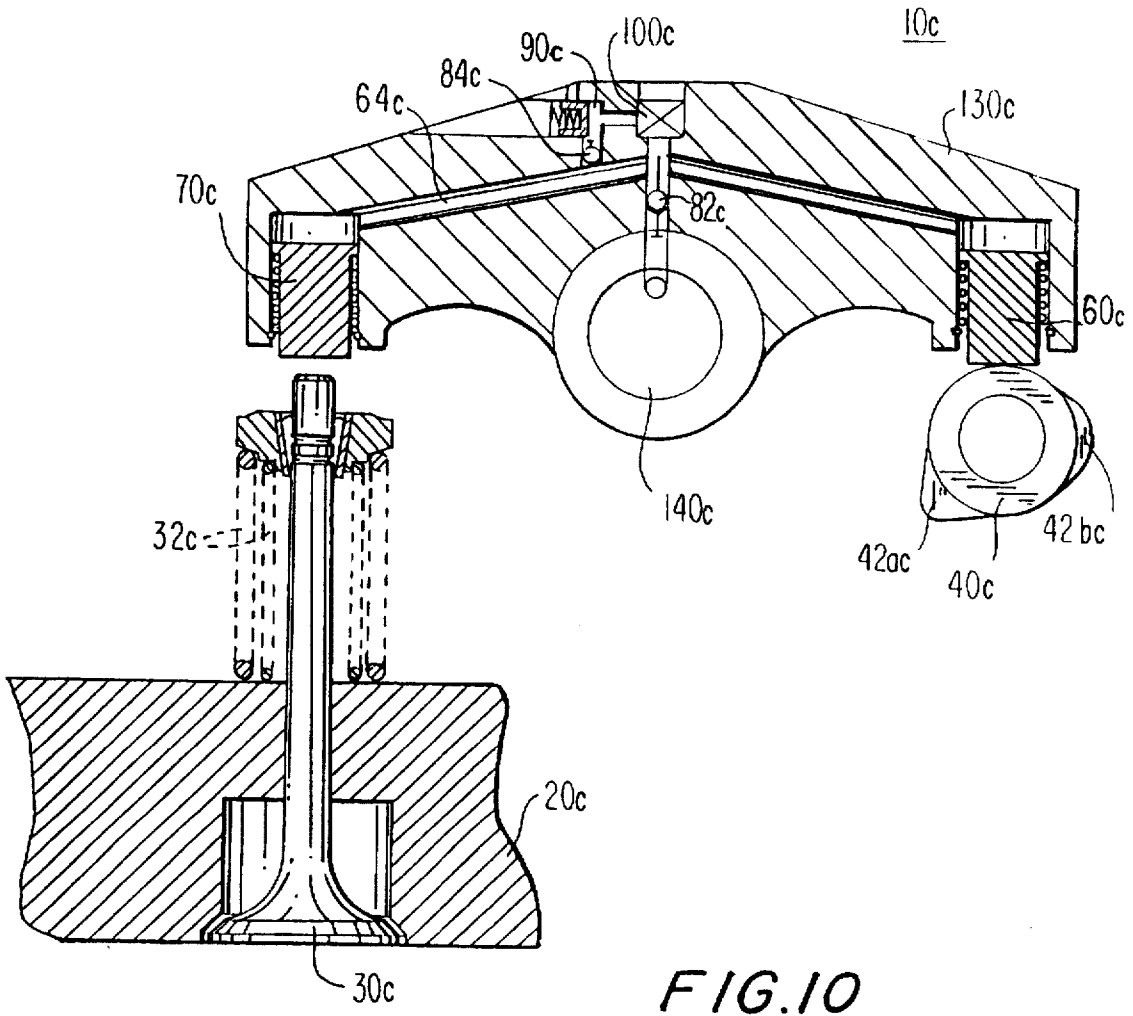

FIG. 10

## INTERNAL COMBUSTION ENGINES WITH COMBINED CAM AND ELECTRO- HYDRAULIC ENGINE VALVE CONTROL

This is a continuation, of application Ser. No. 08/512, 528, filed Aug. 8, 1995, now abandoned entitled INTERNAL COMBUSTION ENGINES WITH COMBINED CAM AND ELECTRO-HYDRAULIC ENGINE VALVE CONTROL.

### BACKGROUND OF THE INVENTION

This invention relates to internal combustion engines, and more particularly to internal combustion engines with valves that are opened by cams cooperating with hydraulic circuits that are partly controlled by electrically operated hydraulic fluid valves.

In most internal combustion engines the engine cylinder intake and exhaust valves are opened and closed (at least for the most part) by cams in the engine. This makes it relatively difficult and perhaps impossible to adjust the timings and/or amounts of engine valve openings to optimize those openings for various engine operating conditions such as changes in engine speed.

It is known to include hydraulic lash adjusting mechanisms in the linkage between an engine cam and the engine cylinder valve controlled by that cam to make it possible to make relatively small adjustments in the valve strokes relative to the profile of the cam (see, for example, Rembold et al. U.S. Pat. No. 5,113,812 and Schmidt et al. U.S. Pat. No. 5,325,825). These lash adjustments may be used to provide additional valve openings when it is desired to convert the engine from positive power mode to compression release engine braking mode (see, for example, Cartledge U.S. Pat. No. 3,809,033 and Gobert et al. U.S. Pat. No. 5,146,890). Hydraulic circuitry may also be used to cause a part of the engine other than the cam which normally controls an engine valve to provide additional openings of the valve when it is desired to convert the engine from positive power mode to compression release engine braking mode (see, for example, Cummins U.S. Pat. No. 3,220,392 and Hu U.S. Pat. No. 5,379,737).

Schechter U.S. Pat. No. 5,255,641 shows in FIG. 16 that an engine cam can be linked to an engine cylinder valve by a hydraulic circuit which includes a solenoid valve for selectively releasing hydraulic fluid from the hydraulic circuit. Schechter points out that various shapes of the engine cylinder valve lift versus the cam curve can be obtained by varying the solenoid voltage pulse timing and duration. However, Schechter does not suggest that any lobe on the cam can be completely overridden in this way. It may not be possible to convert an engine from positive power mode to compression release engine braking mode and vice versa without the ability to selectively completely override any lobe on an engine cam.

Sickler U.S. Pat. No. 4,572,114 shows internal combustion engine cylinder valve control which essentially uses two substantially separate hydraulic circuits for controlling the motion of each engine cylinder valve. One of these two hydraulic circuits controls selective decoupling of each engine cylinder valve from its normal cam-driven mechanical input. The other hydraulic circuit provides alternative hydraulic inputs to the engine cylinder valve when the normal mechanical input is decoupled. The control for these two hydraulic systems may be essentially mechanical and/or hydraulic as in FIG. 5, or it may be essentially electronic as shown in FIG. 7. The two hydraulic circuits may have a

common source of hydraulic fluid and they may have other cross-connections, but they are largely separate in operation and they each require a separate hydraulic connection (e.g., 136 and 212 in FIG. 5 or 258 and 212 in FIG. 7) to each cylinder valve operating mechanism.

From the foregoing it will be seen that the known hydraulic modifications of cam control for engine cylinder valves tend to be either relatively limited in extent and purpose (e.g., as in FIG. 16 of the Schechter patent) or to require relatively complex hydraulic circuitry (e.g., as in the Sickler patent).

It is therefore an object of this invention to provide improved and simplified hydraulic circuitry which can be used to more extensively modify the operation of engine cylinder valves in response to engine cams.

It is another object of this invention to provide relatively simple hydraulic circuitry which can be used selectively to partly or completely suppress any engine valve operation associated with the engine cam that otherwise controls that engine valve, for example, to switch the engine between positive power mode operation and compression release engine braking mode operation and/or to adjust the timing of engine valve openings for various engine operating conditions.

### SUMMARY OF THE INVENTION

These and other objects of the invention are accomplished in accordance with the principles of the invention by providing a hydraulic circuit linkage in the connection between an engine cam and an engine valve associated with that cam. The hydraulic circuit is partly controlled by an electrically operated hydraulic valve (e.g., for selectively relieving hydraulic fluid pressure in the hydraulic circuit). The hydraulic circuit is preferably constructed so that when the electrically operated hydraulic valve relieves hydraulic fluid pressure in that circuit, there is sufficient lost motion between the mechanical input to the circuit and the mechanical output from the circuit to prevent any selected cam function or functions from being transmitted to the engine valve associated with that cam. This allows the electrically controlled hydraulic circuit to fully control which cam function(s) the associated engine valve will respond to and which cam function(s) the engine valve will not respond to. In addition, the electrically operated hydraulic circuit can modify the response of the engine valve to various cam functions (e.g., to modify the timing of engine valve responses to those cam functions). In the preferred embodiments only a single hydraulic fluid connection is needed to the mechanism of each valve. Also in the preferred embodiments the ultimate input for all openings of each engine valve comes from a single cam that is associated with that valve.

Further features of the invention, its nature and various advantages will be more apparent from the accompanying drawings and the following detailed description of the preferred embodiments.

### BRIEF DESCRIPTION OF THE DRAWINGS

FIG. 1 is a simplified schematic diagram of a representative portion of an illustrative embodiment of an internal combustion engine constructed in accordance with the principles of this invention.

FIG. 2a is a simplified diagram of an illustrative signal waveform usable in the apparatus of FIG. 1 or in any of the alternative embodiments shown in FIGS. 8-10.

FIG. 2*b* is a simplified diagram of illustrative motion of an engine cylinder valve in the apparatus of FIG. 1 or in any of the alternative embodiments shown in FIGS. 8-10.

FIGS. 2*c*, 2*e*, 3*a*, 4*a*, 5*a*, 6*a*, 7*a*, 7*c*, 7*e*, and 7*g* are diagrams of the same general kind as FIG. 2*a*.

FIGS. 2*d*, 2*f*, 3*b*, 4*b*, 5*b*, 6*b*, 7*b*, 7*d*, 7*f*, and 7*h* are diagrams of the same general kind as FIG. 2*b*.

FIG. 8 is a diagram similar to FIG. 1 showing an alternative embodiment of the invention.

FIG. 9 is another diagram similar to FIG. 1 showing another alternative embodiment of the invention.

FIG. 10 is yet another diagram similar to FIG. 1 showing yet another alternative embodiment of the invention.

#### DETAILED DESCRIPTION OF THE PREFERRED EMBODIMENTS

As shown in FIG. 1, an illustrative embodiment of an internal combustion engine 10 constructed in accordance with this invention includes an engine cylinder head 20 in which engine cylinder valves such as valve 30 are movably mounted. As is conventional, engine cylinder valves 30 control the flow of gas to and from the cylinders (not shown) of the engine. Representative valve 30 is an exhaust valve, but it will be understood that valve 30 can alternatively be an intake valve, or that both the intake and exhaust valves of the engine can be controlled as will be described for valve 30. Valve 30 is resiliently urged toward its upper (closed) position by prestressed compression coil springs 32.

Openings of valve 30 can be produced by lobes such as 42*a* and 42*b* on rotating engine cam 40. For example, cam 40 may conventionally rotate once for every two revolutions of the engine crankshaft (assuming that the engine is a four-cycle engine). Cam 40 may be synchronized with the engine crankshaft so that cam lobe 42*a* passes master piston 60 (described below) during the exhaust stroke of the engine piston associated with valve 30. Cam lobe 42*a* is therefore the lobe for producing normal exhaust stroke openings of exhaust valve 30 during positive power mode operation of the engine. Cam lobe 42*b* passes master piston 60 near the end of the compression stroke of the engine piston associated with valve 30. Cam lobe 42*b* can therefore be used to produce compression release openings of exhaust valve 30 during compression release engine braking mode operation of the engine. (A possible third cam lobe 42*c* is shown in phantom lines in FIG. 1 for purposes of discussion in connection with FIGS. 7*a* through 7*h*. This third cam lobe should be ignored until the discussion of the FIG. 7 group.) If valve 30 is an intake valve rather than an exhaust valve, then the lobes 42 on the associated cam 40 will have shapes and angular locations different from those shown in FIG. 1, but the underlying operating principles are the same.

Cam 40 is selectively linked to valve 30 by a hydraulic circuit 50 which will now be described. In the embodiment shown in FIG. 1 the structure 52 in which hydraulic circuit 50 is disposed is fixed and stationary relative to engine cylinder head 20. For example, structure 52 may be bolted to head 20.

Hydraulic circuit 50 includes a master piston 60 which can be hydraulically coupled to a slave piston 70. Master piston 60 receives a mechanical input from cam 40 (in particular, the lobes 42 of the cam), and if the hydraulic subcircuit 64 between the master and slave pistons is sufficiently pressurized, that input is hydraulically transmitted to slave piston 70 to cause the slave piston to produce a corresponding mechanical output. This mechanical output of slave piston 70 opens valve 30.

When the engine is operating, hydraulic fluid pump 80 supplies pressurized hydraulic fluid from sump 78 to subcircuit 64 via check valves 82 and 84. The hydraulic fluid pressure supplied by pump 80 is sufficient to push master piston 60 out into contact with the peripheral surface of cam 40 and to push slave piston 70 out into contact with the upper end of the stem of valve 30, but it is not sufficient to cause slave piston 70 to open valve 30. For example, the hydraulic fluid pressure supplied by pump 80 may be approximately 50 to 100 psi. Any over-pressure produced by pump 80 is relieved by relief valve 86, which returns hydraulic fluid to the inlet of pump 80. The hydraulic fluid may be engine lubricating oil, engine fuel, or any other suitable fluid.

Hydraulic fluid accumulator 90 helps keep subcircuit 64 filled with hydraulic fluid of at least approximately the output pressure produced by pump 80. An electrically controlled hydraulic valve 100 is provided for selectively relieving hydraulic fluid pressure (above the output pressure of pump 80) from subcircuit 64. When valve 100 is closed, hydraulic fluid is trapped in subcircuit 64. Subcircuit 64 will then hydraulically transmit a mechanical input from cam 40 and master piston 60 to slave piston 70, thereby causing the slave piston to produce a mechanical output which opens valve 30. On the other hand, when valve 100 is open, hydraulic fluid can escape from subcircuit 64 to accumulator 90. This prevents subcircuit 64 from transmitting an input from cam 40 and master piston 60 to slave piston 70. Valve 30 therefore does not open in response to the cam input. Preferably valve 100 can vent from subcircuit 64 all the hydraulic fluid flow produced by the longest stroke of master piston 60 that results from any lobe 42 on cam 40. In this way valve 100 can be used to effectively completely cancel or suppress (by means of lost motion in subcircuit 64) any input from cam 40. If accumulator 90 receives too much hydraulic fluid, its plunger moves far enough to the left to momentarily open a drain 92 back to hydraulic fluid sump 78.

Valve 100 is controlled by electronic control circuitry 110 associated with engine 10. Control circuit 110 receives various inputs 112 from engine and vehicle instrumentation 114 (which may include inputs initiated by the driver of the vehicle) and produces output signals 108 for appropriately controlling valve 100 (and other similar valves in engine 10). For example, control circuit 110 may control valve 100 differently depending on such factors as the speed of the engine or vehicle, whether the engine is in positive power mode or compression release engine braking mode, etc. Control circuit 110 may include a suitably programmed microprocessor for performing algorithms or look-up table operations to determine output signals 108 appropriate to the inputs 112 that the control circuit is currently receiving. Instrumentation 114 includes engine sensors (e.g., an engine crankangle position sensor) for maintaining basic synchronization between the engine and control circuit 110.

FIGS. 2*a* through 2*f* show illustrative control signals for valves like valve 100 and resulting motions of engine valves like valve 30 under various engine operating conditions. For example, FIG. 2*a* shows the signal 108 from control circuit 110 for controlling the valve 100 associated with the exhaust valve(s) 30 of a typical engine cylinder during positive power mode operation of the engine. (In connection with FIG. 2*a* and other similar Figures the associated valve 100 is closed when the signal trace is high. The numbers along the base line in FIG. 2*a* are engine crankangle degrees and apply as well for all of the Figures below FIG. 2*a*.) FIG. 2*c* shows the corresponding signal 108 during compression release engine braking operation of the engine. FIG. 2*e*

shows the signal 108 from control circuit 110 for controlling the valve 100 associated with the intake valve(s) 30 of the same engine cylinder with which FIGS. 2a and 2c are associated. In this example FIG. 2e is the same for both positive power and compression release engine braking mode operation of the engine.

As shown in FIGS. 2a and 2b, because the valve 100 associated with the hydraulic subcircuit 64 for the exhaust valve is closed when the exhaust lobe 42a on cam 40 passes master piston 60, that lobe causes exhaust valve 30 to open as shown in FIG. 2b during the exhaust stroke of the associated engine cylinder (i.e., between engine crankangles 180° and 360°). This is the motion of exhaust valve 30 that is appropriate for positive power mode operation of the engine. FIG. 2a shows that valve 100 is open when compression release lobe 42b on cam 40 passes master piston 60 (near engine crankangle 0° or 720°). Exhaust valve 30 therefore does not open in response to lobe 42b. On the other hand, FIGS. 2c and 2d show valve 100 being closed near top dead center of each compression stroke of the engine cylinder (engine crankangle 0° or 720°) but open during the exhaust stroke of that cylinder. This causes exhaust valve 30 to open as shown in FIG. 2d in response to compression release lobe 42b passing master piston 60, but it allows exhaust valve 30 to remain closed as exhaust lobe 42a passes master piston 60. FIGS. 2e and 2f show that the valve 100 associated with the intake valve of the engine cylinder is closed during the intake stroke of the engine cylinder (between engine crankangles 360° and 540°). This causes the intake valve 30 of that cylinder to open as shown in FIG. 2f in response to an intake lobe on an intake valve control cam 40 associated with that engine cylinder. In this embodiment the operation of the intake valve remains the same for positive power mode and compression release engine braking mode operation of the engine.

Additionally or alternatively to allowing selection of which cam lobes 42 the engine valves 30 will respond to, the apparatus of this invention allows the response of the engine valves 30 to any cam lobe to be varied if desired. For example, FIGS. 3a and 3b are respectively similar to FIGS. 2a and 2b, but show that if control circuit 110 delays the closing of valve 100 somewhat (as compared to FIG. 2a), valve 30 begins to open somewhat later. In other words, the first part of exhaust lobe 42a is suppressed or ignored. In addition, because some hydraulic fluid is allowed to escape from subcircuit 64 during the initial part of exhaust lobe 42a, valve 30 does not open as far in FIG. 3b as it does in FIG. 2b, and valve 30 closes sooner in FIG. 3b than in FIG. 2b. The principles illustrated by FIGS. 3a and 3b are equally applicable to any of the other types of valve motion shown in the FIG. 2 group.

FIGS. 4a and 4b show another example of using valve 100 to modify the response of engine valve 30 to cam lobe 42a. Again, FIGS. 4a and 4b are respectively similar to FIGS. 2a and 2b, but show control circuit 110 re-opening valve 100 sooner than is shown in FIG. 2a. As shown in FIG. 4b this causes engine valve 30 to re-close sooner than in FIG. 2b. Re-opening valve 100 before the final portion of cam lobe 42a has passed master piston 60 causes valve 30 to ignore that final portion of the cam lobe, thereby allowing valve 30 to re-close sooner than it would under full control of the cam. Again, the principles illustrated by FIGS. 4a and 4b are equally applicable to any of the other types of valve motion shown in the FIG. 2 or FIG. 3 groups.

FIGS. 5a and 5b show yet another example of using valve 100 to modify the response of engine valve 30 to cam lobe 42a. Again FIGS. 5a and 5b are respectively similar to

FIGS. 2a and 2b. FIG. 5a shows control circuit 110 opening the associated valve 100 briefly as exhaust lobe 42a approaches its peak. This allows some hydraulic fluid to escape from subcircuit 64, thereby preventing valve 30 from opening quite as far as in FIG. 2b. As another consequence, valve 30 re-closes somewhat earlier than in FIG. 2b.

Another example of modulation of valve 100 of the general type shown in FIG. 5a is illustrated by FIGS. 6a and 6b. Once again, FIGS. 6a and 6b are respectively similar to FIGS. 2a and 2b, except that during the latter portion of exhaust lobe 42a control circuit 110 begins to rapidly open and close valve 100. This enables some hydraulic fluid to escape from subcircuit 64, which accelerates the closing of valve 30, although the valve 30 closing still remains partly under the control of exhaust lobe 42a. The principles illustrated by FIGS. 5a through 6b are equally applicable to any of the other types of valve motion shown in the FIG. 2, FIG. 3, or FIG. 4 groups. Moreover, valve modulation of the type shown in FIG. 6a and with any desired duty cycle (ratio of valve open time to valve close time) can be used at any time during a cam lobe to provide any of a wide range of modifications of the response of the associated engine valve to the cam lobe.

FIGS. 7a through 7h illustrate how the apparatus of this invention can be used to cause engine 10 to operate in another way during compression release engine braking. FIGS. 7a through 7d are respectively similar to FIGS. 2a, 2b, 2e, and 2f and show the same positive power mode operation of the engine as is shown in the FIG. 2 group. FIG. 7e shows control of the valve 100 associated with the exhaust valve(s) during compression release engine braking, and FIG. 7g shows control of the valve 100 associated with the intake valve(s) during compression release engine braking. FIGS. 7f and 7h show exhaust and intake valve motion, respectively, during compression release engine braking. In order to produce additional exhaust valve openings 120 in FIG. 7f, an additional lobe 42c (FIG. 1) is provided on cam 40. As shown in FIG. 7e, during compression release engine braking the valve 100 associated with the exhaust valve(s) is opened throughout the normal exhaust stroke of the engine to suppress the normal exhaust valve opening. However, this valve 100 is closed near the end of the expansion stroke (near engine crankangle 540°) and again near the end of the compression stroke (near engine crankangle 0° or 720°). This causes exhaust valve 30 to open (as at 120) in response to cam lobe 40c near the end of the expansion stroke (to charge the engine cylinder with a reverse flow of gas from the exhaust manifold of the engine). Exhaust valve 30 opens again in response to cam lobe 42b near the end of the compression stroke (to produce a compression release event for compression release engine braking). FIGS. 7g and 7h show that the associated intake valve 30 is not opened at all during this type of compression release engine braking operation.

The type of compression release engine braking operation shown in FIGS. 7e through 7h may be especially advantageous when the engine is equipped with an exhaust brake for substantially closing the exhaust system of the engine when engine retarding is desired. This increases the pressure in the exhaust manifold of the engine, making it possible to supercharge the engine cylinder when exhaust valve opening 120 occurs. This supercharge increases the work the engine must do during the compression stroke, thereby increasing the compression release retarding the engine can produce.

FIGS. 2a through 7h show that the apparatus of this invention can be used to modify the responses of the engine valves to the engine cam lobes in many different ways.

These include complete omission of certain cam lobes at certain times, or more subtle alteration of the timing or extent of engine valve motion in response to a cam lobe. These modifications may be made to change the mode of operation of the engine (e.g., from positive power mode to compression release engine braking mode or vice versa) or to optimize the performance of the engine for various engine or vehicle operation conditions (e.g., changes in engine or vehicle speed) as sensed by engine or vehicle instrumentation 114.

FIG. 8 shows an alternative embodiment of the invention in which the electrically controlled hydraulic circuitry of this invention is partly built into the overhead rockers of engine 10a. (To the extent that components in FIG. 8 are related to components in FIG. 1, the same reference numbers are used again in FIG. 8, but with a suffix letter "a". Substantially new elements in FIG. 8 have previously unused reference numbers, but again a suffix letter "a" is added for uniformity of references to FIG. 8.)

As shown in FIG. 8, representative rocker 130a is rotatably mounted on rocker shaft 140a. The right-hand portion of rocker 130a (as viewed in FIG. 8) carries a rotatable cam follower roller 132a which bears on the peripheral cam surface of rotating cam 40a. Hydraulic subcircuit 64a extends from a source of pressurized hydraulic fluid (which extends along shaft 140a) to a slave piston 70a (which is mounted for reciprocation in the left-hand portion of rocker 130a). The ultimate source of the pressurized hydraulic fluid in shaft 140a may be a pump arrangement similar to elements 78, 80, and 86 in FIG. 1. Electrically controlled hydraulic valve 100a can selectively release hydraulic fluid from subcircuit 64a out over the top of rocker 130a. Valve 100a is controlled by control circuitry similar to element 110 in FIG. 1.

The apparatus of FIG. 8 can be made to operate in a manner similar to that described above for FIG. 1. The pressure of the hydraulic fluid supply is great enough to push slave piston 70a out into contact with the upper end of engine valve 30a. However, this pressure is not great enough to open valve 30a against the valve-closing force of springs 32a. If valve 100a is closed when a cam lobe 42aa or 42ba passes roller 132a, the hydraulic fluid trapped in subcircuit 64a causes slave piston 70a to open valve 30a. On the other hand, if valve 100a is open when a cam lobe 42aa or 42ba passes roller 132a, slave piston 70a will move into rocker 130a, thereby expelling some hydraulic fluid from subcircuit 64a and allowing valve 30a to remain closed despite the passage of a cam lobe 42. Any of the techniques for modifying engine valve response to cam lobes that are illustrated by FIGS. 2a through 7h are equally applicable to the embodiment shown in FIG. 8. Thus it is again preferred that the lost motion available in hydraulic subcircuit 64a is sufficient to allow any lobe on cam 40a to be completely ignored. More subtle modifications of the timing and/or extent of engine valve response to cam lobes are also possible as is discussed above in connection with FIGS. 2a through 7h.

FIG. 9 shows another embodiment which is similar to the embodiment shown in FIG. 8 but with the addition of accumulator 90b and check valve 84b, respectively similar to accumulator 90 and check valve 84 in FIG. 1. Elements in FIG. 9 that are similar to elements in FIG. 8 have the same reference numbers, but with the suffix letter "b" rather than "a" as in FIG. 8. When valve 100b is open, it releases hydraulic fluid from subcircuit 64b to accumulator 90b in a manner similar to the embodiment shown in FIG. 1. In other respects the operation of the FIG. 9 embodiment is similar

to operation of the embodiment shown in FIG. 8, and thus it will not be necessary to repeat the explanation of FIG. 8 for FIG. 9.

FIG. 10 shows yet another embodiment which is similar to the embodiment shown in FIG. 9 but with the addition of master piston 60c (similar to master piston 60 in FIG. 1) to hydraulic subcircuit 64c. Elements in FIG. 10 which are similar to elements in FIG. 9 have the same reference numbers, but with the suffix letter "c" rather than "b" as in FIG. 9. The operation of this embodiment is similar to that of the embodiment shown in FIG. 9, so it will not be necessary to repeat the explanation of FIG. 9 for FIG. 10.

It will be understood that the foregoing is only illustrative of the principles of the invention, and that various modifications can be made by those skilled in the art without departing from the scope and spirit of the invention. For example, while FIGS. 1 and 8-10 suggest that there is one exhaust or intake valve 30 per engine cylinder, it is quite common to provide two valves of each type in each cylinder. The apparatus of this invention can be readily modified to control multiple intake and/or exhaust valves per cylinder.

The invention claimed is:

1. An internal combustion engine comprising:

an engine cylinder valve which is selectively openable and closable;

a cam having a plurality of lobes synchronized with possible openings of said engine cylinder valve;

a hydraulic linkage containing hydraulic fluid operatively coupled between said cam and said engine cylinder valve for selectively responding to said lobes by causing said valve to open; and

a hydraulic fluid control for selectively controlling hydraulic fluid pressure in said hydraulic linkage to selectively modify the openings of said engine cylinder valve in response to said lobe, said hydraulic fluid control being selectively operable to allow said engine cylinder valve to remain completely closed in response to a first one of said lobes and to open in response to a second one of said lobes, each of said plurality of lobes being selectable at various times to be either said first one or said second one of said lobes.

2. The apparatus defined in claim 1 wherein said hydraulic fluid control comprises a valve for selectively releasing hydraulic fluid from said hydraulic linkage.

3. The apparatus defined in claim 2 wherein said valve is an electrically operated valve controlled by electronic control circuitry.

4. The apparatus defined in claim 3 wherein said electronic control circuitry includes a microprocessor.

5. The apparatus defined in claim 1 further comprising: a supply of hydraulic fluid at a first, relatively low, positive pressure; and

a check valve for allowing said hydraulic fluid to flow from said supply into said hydraulic linkage but not in an opposite direction, said first pressure being insufficient to cause said hydraulic linkage to open said engine cylinder valve.

6. The apparatus defined in claim 5 wherein said supply comprises a hydraulic fluid accumulator for maintaining a quantity of hydraulic fluid at approximately said first pressure, and wherein said hydraulic fluid control comprises an electrically operated valve for selectively releasing hydraulic fluid from said hydraulic linkage to said accumulator.

7. The apparatus defined in claim 6 further comprising: electronic control circuitry for controlling said electrically operated valve.

8. The apparatus defined in claim 7 wherein said electronic control circuitry includes a microprocessor.

9. The apparatus defined in claim 1 wherein said hydraulic linkage comprises:

a master piston that reciprocates in response to said lobes; and

a slave piston that selectively reciprocates in response to hydraulic fluid pressure and flow in said hydraulic linkage in order to selectively open said engine cylinder valve.

10. The apparatus defined in claim 1 wherein said hydraulic linkage is disposed in a rocker arm which rocks in response to said lobes.

11. The apparatus defined in claim 10 wherein said hydraulic linkage comprises a slave piston disposed in said rocker arm, said slave piston being reciprocable relative to said rocker arm in response to hydraulic fluid pressure and flow in said hydraulic linkage in order to selectively open said engine cylinder valve.

12. The apparatus defined in claim 1 wherein said hydraulic linkage is disposed in a rocker arm which selectively rocks in response to said lobes.

13. The apparatus defined in claim 12 wherein said hydraulic linkage comprises:

a master piston that is reciprocable relative to said rocker arm in response to said lobes; and

a slave piston that is reciprocable relative to said rocker arm in response to hydraulic fluid pressure and flow in said hydraulic linkage in order to selectively open said engine cylinder valve.

14. The apparatus defined in claim 1 wherein said engine cylinder valve is an exhaust valve, wherein said lobes include an exhaust lobe and a compression release lobe, and wherein said hydraulic fluid control is responsive to whether said engine is in a positive power mode of operation or a compression release engine braking mode of operation by controlling hydraulic fluid pressure in said hydraulic linkage so that said exhaust valve opens in response to said compression release lobe only when said engine is in said compression release engine braking mode of operation.

15. The apparatus defined in claim 14 wherein said hydraulic fluid control is further responsive to the mode of operation of said engine by controlling hydraulic fluid pressure in said hydraulic linkage so that said exhaust valve opens in response to said exhaust lobe only when said engine is in said positive power mode of operation.

16. The apparatus defined in claim 15 wherein said cam additionally has a reverse exhaust gas flow lobe, and wherein said hydraulic fluid control is further responsive to the mode of operation of said engine by controlling hydraulic fluid pressure in said hydraulic linkage so that said exhaust valve opens in response to said reverse exhaust gas flow lobe only when said engine is in said compression release engine braking mode.

17. The apparatus defined in claim 1 wherein said hydraulic fluid control selectively delays an opening of said engine cylinder valve in response to one of said lobes by substantially preventing hydraulic fluid pressure increase in said hydraulic linkage during an initial portion of said lobe.

18. The apparatus defined in claim 1 wherein said hydraulic fluid control selectively reduces the amount by which said engine cylinder valve opens in response to one of said lobes by allowing hydraulic fluid to escape from said hydraulic fluid linkage during a portion of said lobe.

19. The apparatus defined in claim 1 wherein said hydraulic fluid control selectively advances in time the re-closing of said engine cylinder valve after opening in response to

one of said lobes by allowing hydraulic fluid to escape from said hydraulic fluid linkage during a portion of said lobe.

20. The apparatus defined in claim 1 wherein said engine cylinder valve reciprocates relative to a cylinder head of said engine, and wherein said hydraulic linkage is disposed in a structure which is fixed and stationary relative to said cylinder head.

21. The method of operating an internal combustion engine which has a selectively openable engine cylinder valve, a cam having an exhaust lobe and a compression release lobe, and a hydraulic linkage containing hydraulic fluid operatively coupled between said cam and said engine cylinder valve for selectively responding to said exhaust and compression release lobes by selectively opening said engine cylinder valve, said method comprising the steps of:

detecting whether said engine is in a positive power mode of operation or a compression release engine braking mode of operation;

if said engine is in said positive power mode of operation, controlling hydraulic fluid pressure in said hydraulic linkage so that said hydraulic linkage opens said engine cylinder valve in response to said exhaust lobe but not in response to said compression release lobe; and

if said engine is in said compression release mode of operation, controlling hydraulic fluid pressure in said hydraulic linkage so that said hydraulic linkage opens said engine cylinder valve in response to said compression release lobe but not in response to said exhaust lobe.

22. The method defined in claim 21 wherein said step of controlling, when said engine is in said positive power mode of operation, comprises the steps of:

trapping said hydraulic fluid in said hydraulic linkage during response of said hydraulic linkage to said exhaust lobe; and

allowing said hydraulic fluid to escape from said hydraulic linkage during response of said hydraulic linkage to said compression release lobe.

23. The method defined in claim 21 wherein said step of controlling, when said engine is in said compression release engine braking mode of operation, comprises the steps of:

trapping said hydraulic fluid in said hydraulic linkage during response of said hydraulic linkage to said compression release lobe; and

allowing said hydraulic fluid to escape from said hydraulic linkage during response of said hydraulic linkage to said exhaust lobe.

24. The method defined in claim 21 wherein at least one of said controlling steps comprises the steps of:

trapping said hydraulic fluid in said hydraulic linkage during a first portion of response of said hydraulic linkage to at least one of said lobes; and

allowing some of said hydraulic fluid to escape from said hydraulic linkage during a second portion of the response of said hydraulic linkage to said at least one of said lobes.

25. The method defined in claim 24 wherein said second portion is an initial portion of the response of said hydraulic linkage to said at least one of said lobes.

26. The method defined in claim 24 wherein said second portion is an intermediate portion of the response of said hydraulic linkage to said at least one of said lobes.

27. The method defined in claim 26 wherein said first portion precedes said intermediate portion.

28. The method defined in claim 27 wherein said at least one of said controlling steps further comprises the step of:

11

retrapping said hydraulic fluid in said hydraulic linkage during a third portion of the response of said hydraulic linkage to said at least one of said lobes, said third portion following said intermediate portion.

29. The method defined in claim 24 wherein said portion is a final portion of the response of said hydraulic linkage to said at least one of said lobes.

30. A compression release braking system for an internal combustion engine comprising:

an engine cylinder exhaust valve which is selectively openable and closable;

a cam having a compression release engine braking lobe synchronized with a possible compression release opening of said exhaust valve;

a hydraulic linkage containing hydraulic fluid operatively coupled between said cam and said exhaust valve for selectively responding to said lobe by causing said valve to open; and

a hydraulic fluid control responsive to a variable operating condition of said engine for selectively modifying hydraulic fluid pressure in said hydraulic linkage during response of said hydraulic linkage to said lobe to selectively modify the openings of said exhaust valve in response to said lobe so that said openings are adapted to a current value of said variable operating condition.

31. The apparatus defined in claim 30 wherein said hydraulic fluid control controls said hydraulic fluid pressure in said hydraulic linkage by selectively releasing hydraulic fluid from said hydraulic fluid linkage.

12

32. The apparatus defined in claim 30 wherein said hydraulic fluid control comprises a microprocessor.

33. The apparatus defined in claim 30 wherein said hydraulic linkage comprises:

a master piston reciprocable by said lobe to cause a flow of hydraulic fluid in said hydraulic linkage; and

a slave piston reciprocable by hydraulic fluid pressure and flow in said hydraulic linkage to open said exhaust valve.

34. The apparatus defined in claim 30 wherein said hydraulic linkage is disposed in a rocker arm which is selectively rockable by said lobe.

35. The apparatus defined in claim 30 wherein said hydraulic fluid control selectively modifies commencement time of said openings relative to commencement time of said lobe.

36. The apparatus defined in claim 30 wherein said hydraulic fluid control selectively modifies end termination time of said openings relative to end termination time of said lobe.

37. The apparatus defined in claim 30 wherein said hydraulic fluid control selectively modifies opening distance of said openings relative to profile prominence of said lobe.

38. The apparatus defined in claim 30 wherein said exhaust valve reciprocates relative to a cylinder head of said engine, and wherein said hydraulic linkage is disposed in a structure which is fixed and stationary relative to said cylinder head.

\* \* \* \* \*