



(72) LEKSON, MATTHEW ANDREW, US
(72) JIAO, JIANZHONG, US
(71) NORTH AMERICAN LIGHTING, INC., US

(51) Int.Cl.⁷ F21V 8/00

(30) 1999/08/11 (09/372,567) US

(54) **DISPOSITIF D’AFFICHAGE UTILISANT UN CONDUIT DE
LUMIERE POUR L’ECLAIRAGE EXTERIEUR DE
VEHICULES AUTOMOBILES**

(54) **DISPLAY DEVICE USING A LIGHT GUIDE FOR EXTERIOR
AUTOMOTIVE LIGHTING**

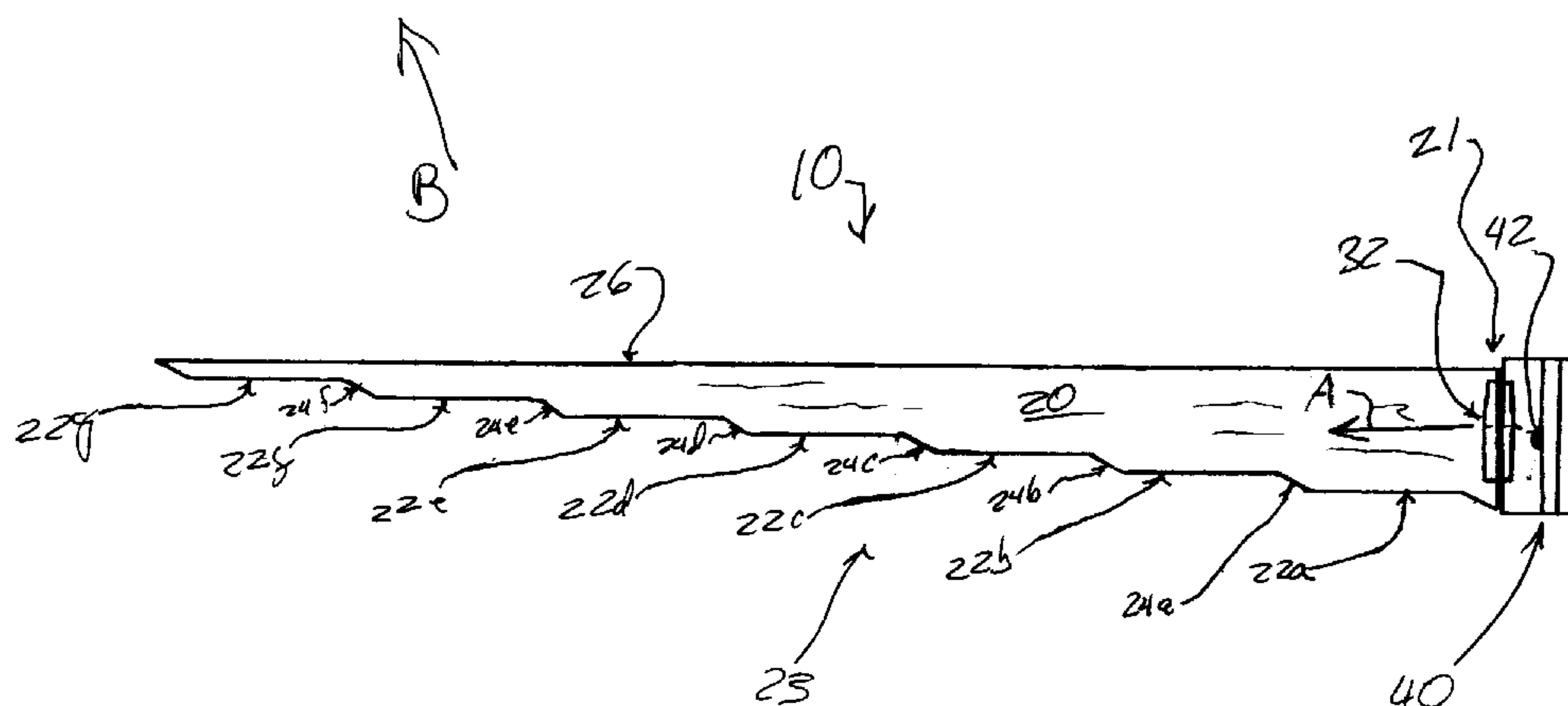

(57) A display device is provided for providing lighting in exterior and interior lighting applications, such as for center high mount stop lights (CHMSL) and other automotive lighting applications. The display device uses a light guide having light couplers on a light source end for receiving light from at least one light source. The light guide extends from the light source end with a light emitting surface and a light guide surface opposite the light emitting surface. The light emitting surface and the light guide surface extend in a direction substantially parallel to the direction of the light received from the light source. The light guide surface has a plurality of surface sections extending at angles relative to one another. The surface sections may be angled at alternating sections direct light towards the light emitting surface using total internal reflection.

ABSTRACT

A display device is provided for providing lighting in exterior and interior lighting applications, such as for center high mount stop lights (CHMSL) and other automotive lighting applications. The display device uses a light guide having light
5 couplers on a light source end for receiving light from at least one light source. The light guide extends from the light source end with a light emitting surface and a light guide surface opposite the light emitting surface. The light emitting surface and the light guide surface extend in a direction substantially parallel to the direction of the light received from the light source. The light guide surface has a plurality of surface
10 sections extending at angles relative to one another. The surface sections may be angled at alternating sections direct light towards the light emitting surface using total internal reflection.

DISPLAY DEVICE USING A LIGHT GUIDE FOR EXTERIOR AUTOMOTIVE LIGHTING

BACKGROUND OF THE INVENTION

5 **A. Field of the Invention**

The present invention relates to the field of illuminating systems, and more particularly to the field of display devices used in automotive lighting.

B. Description of Related Art

Center high mount stop lights (CHMSL) are red colored, light emitting display
10 devices that are mounted to illuminate to the rear of an automobile from a position that is elevated and roughly center to the stop lights on the right and left sides of the rear end of the automobile. Conventional CHMSLs consist of a lamp assembly having a housing containing an external lens with a bulb. The housing typically has a reflective coating on the inside surface. The lamp assembly may come in various
15 shapes and sizes. Many of these assemblies require several components to be connected together. For example, in addition to the lens and housing, a separate bracket may be included to facilitate the attachment of a bulb socket. The complexity of the structure of CHMSLs may add significantly to the cost of manufacturing the CHMSLs. This in turn adds to the cost of the automobile.

20 CHMSLs may be mounted in any part of the rear of the automobile that allows the CHMSL to be elevated and centered relative to the low-mounted brake lights. Because of its elevated position, the visibility of CHMSLs may be improved by designing it to illuminate with a high-intensity beam having a light spread distribution in the vertical direction that facilitates visibility from different elevations.

25 Manufacturers are now required to produce CMHSLs having a light spread distribution in accordance with specifications set by government regulations, such as

for example, the FMVSS 571.108 issued by the National Highway Traffic Safety Administration.

The use of light guides for exterior lighting is known in the art. U.S. Patent No. 5,772,304 to Smith (hereinafter "Smith") discloses a rear exterior lamp that uses a light guide in which a three dimensional tapered surface reflects light through a light panel. One disadvantage of using Smith, particularly for use as a CHMSL, is that the light emitted by the light panel having the tapered surface does not diverge to provide a light spread distribution. The light emitted by Smith is substantially parallel making it unsuitable for use as a CHMSL or any other exterior lighting requiring a light spread distribution. Smith also requires a light panel and other parts that result in a structure that significantly complex making it a costly solution in terms of labor and material.

U.S. Patent Application 5,165,772 to Wu (hereinafter "Wu") discloses a visual display device structure using a light guide that is particularly designed for use as a CHMSL. The device in Wu includes a substrate material that is stepped on one surface, each step being at an angle to provide a light distribution spread using the light diverging through refraction at the step. One disadvantage with using Wu, however, is that its use is limited to CHMSLs that are mounted at small angles. Another disadvantage with Wu is that the stepped surface makes the light guide in Wu unsuitable for use as exterior lighting.

One of ordinary skill in the art will appreciate that while the present discussion focuses on CHMSLs, the principles, problems and solutions may also apply to other lighting systems. For example, it may be desirable in other lighting applications such as tail lights, other signal lights for automobiles, street lights, interior lighting,

courtesy lighting and other signal lighting to illuminate at a selected light spread distribution.

It would be desirable to have an exterior lighting system that may be made to provide a high-intensity beam with a selected light spread distribution.

5 It would also be desirable to provide an exterior light with a simple structure that may be manufactured at a low cost. For example, it would be desirable to have an exterior light that uses no external lens.

It would also be desirable to provide an external lighting system that is flexible in design to permit a variety of configurations and unique appearance.

SUMMARY OF THE INVENTION

In view of the above, a display device is provided that uses at least one light source operable to radiate a light in a first direction. At least one light coupler is adjacent to the at least one light source to receive the light and to distribute the light in the first direction. A light guide made of a substrate material is provided having a light source end adjacent to the at least one light coupler to receive the distributed light. A light emitting surface extends from the light source end substantially along the first direction. A light guide surface extends from the light source substantially along the first direction and opposite the light emitting surface. The light guide surface includes a plurality of first surface sections. Each first surface section is separated by at least one of a plurality of second surface sections. The first surface sections extend at different angles from the second surface sections. At least one of the first and second surface sections is at a reflective angle to provide reflection of the light generated by the light source. The reflected light is emitted from the light emitting surface with a light distribution spread in a second direction.

BRIEF DESCRIPTION OF THE DRAWINGS

Presently preferred embodiments of the invention are described below in conjunction with the appended drawing figures, wherein like reference numerals refer to like elements in the various figures, and wherein:

5 Figure 1 is a side view of a display device according to one embodiment of the invention;

 Figure 2 is a perspective view of the display device shown in Figure 1;

 Figure 3 is a side view of the display device of Figure 1 showing light generated from the light source and emitted from the light guide; and

10 Figures 4A and 4B are cross-sectional views of the display device in Figure 3 at the section 4-4'.

DETAILED DESCRIPTION OF THE PREFERRED EMBODIMENT

Figure 1 is a side view of a display device **10** having a light source assembly **40**, at least one light coupler **32** and a light guide **20**. The light guide **20** has a light source end **21** physically joined to the light coupler **32** and to the light source assembly **40**. The light source assembly **40** includes at least one light source **42** for generating a light that radiates generally parallel to the length of the light guide as indicated by the arrow labeled **A**. The light is passed through by the light coupler **32** into the light guide **20**.

The light guide **20** includes a light emitting surface **26** and a light guide surface **23**. The light guide **20** is composed of a substrate material that has a refractive index that is greater than the medium contacting the light emitting surface **26** and the light guide surface **23**. The light emitting surface **26** of the display device **10** shown in Figure 1 is advantageously a smooth surface precluding the need for a separate exterior lens. The medium contacting the light emitting surface **26** is therefore typically air. The medium contacting the light guide surface **23** may be any medium having a refractive index that is less than that of the substrate material.

The light guide surface **23** has a plurality of first surface sections **22a-g** and a plurality of second surface sections **24a-f**. The first and second surface sections **22a-g**, **24a-f** are generally planar sections extending from the light source end **21** at planar angles to one another. The angular relationship between the first and second surface sections **22a-g**, **24a-f** direct the light within the light guide **20** by total internal reflection. The light radiating in the direction **A** that is incident to the first and/or second surface sections **22a-g**, **24a-f** at an angle that is less than a critical angle for total internal reflection is reflected towards the light emitting surface **26**. The light is reflected such that it is incident to the light emitting surface **26** at an angle that is

greater than the critical angle and therefore refracted out in the general direction at **B**. In accordance with the principles of total internal reflection, the critical angle is the angle formed by the direction of the incident light and the surface upon which it is incident beyond which the incident light is refracted through the surface.

5 The light guide **20** is composed of a solid substrate material such as moldable plastics or glass. Moldable plastics that may be used include acrylic and polycarbonates. The substrate material may be made of a colored material (*e.g.* red, yellow, etc.) in accordance with the specific purpose for which the light is to be used. For example, if the display device **10** is used as a center high-mount stop light
10 (CHMSL) it will be colored red. Alternatively, the substrate material may be a clear color such that the color of the light emitted may be determined by the light source.

 The light source assembly **40** includes at least one light source **42**. The light source **42** may include any light source that may be used in exterior automotive lighting, such as a light emitting diode (LED), a fiber optic device output, and an
15 incandescent lamp. The light source **42** may also include neon or other tubular sources such as cold cathode fluorescent sources. In a preferred embodiment, the light source **42** includes a plurality of LEDs arranged linearly at the light source end **21** of the light guide **20**. The LED may be any color such as red, yellow, or white.

 Figure 2 is a perspective view of the display device **10** of Figure 1. The light
20 source assembly **40** in Figure 2 is depicted as transparent to illustrate any relevant detail inside the assembly **40**. The light source assembly **40** includes a light source circuit board **44** on which the light sources **42a-f** are mounted. The light sources **42** may be surface-mounted, or mounted on leads. Each light source **42a-f** includes a connection **50** that is connected to an activator that controls the on and off state of the

display device **10**. For example, the activator may be a brake pedal in an automobile, such that when the brake pedal is depressed, the display device **10** illuminates light.

Shown in Figure 2, each light source **42a-f** is positioned in close proximity to a corresponding light coupler **32a-f**. The light couplers **32a-f** receive the light
5 generated by the light sources **42a-f** and couples the light into the light guide **20**. In a preferred embodiment, the light couplers **32a-f** diverge or spread the light such that, incident light passes through the light guide at angles that permit reflection off of the first and/or second surface sections **22, 24**. The light couplers **32a-f** may collimate the light, or couple collimated light, such that it reflects off any of the second surface
10 sections **22a-g, 24a-f** that are not parallel to the direction of the light at **A**.

The light sources **42a-f** shown in Figure 2 are mounted on a light source circuit board **44**, however, the light sources **42a-f** may be mounted in the light source assembly **40** without a light source circuit board **44**. For example, incandescent lamps may be positioned within the light source assembly **40** with a reflective backing that
15 reflects light in the direction the light guide **20**. The reflective backing may be provided by coating the inside surface of the light source assembly **40** with a reflective material. In addition, a fiber optic source may emit light through a fiber optic cable for each light source **42a-f**.

The perspective view in Figure 2 shows the manner in which the first and
20 second surface sections **22, 24** directs the light toward light emitting surface **26**. The illumination provided by the display device **10** gives it a unique appearance that may be modified by using different orientations and angles for the surface sections **22, 24**. In the light guide **20** in Figure 2, the first surface sections **22a-g** are oriented substantially parallel to the light emitting surface **26**. Different orientations having
25 different angles between the first and second surface sections **22, 24** may be used to

provide illumination in the direction at **B** with selected lights spread distribution. In addition, the configurations of the first and second surface sections **22, 24** may also be modified to vary the appearance of the display device **10** in its illuminated state. A further advantage of the display device **10** is that it may be designed to reflect light at a variety of different angles from vertical. The orientation of the first surface sections **22a-g** may also influence the efficiency of the system as well.

Figure 3 is a side view of the display device **10** showing light traveling through the light guide and reflecting off the surface sections to provide illumination through the light emitting surface **26**. The light radiated at **80** from the light emitting surface **26** has a light spread distribution indicated by an angle α_1 . The light is generated by the light source **42** and transmitted through the light guide **20** at an internal light spread distribution indicated by angle α_2 . Figure 3 shows how the internal light spread distribution angle α_2 , the substrate material (*i.e.* its refractive index), total internal reflection off of the surface sections **22, 24** and refraction at the light emitting surface **26** may determine the light spread distribution at angle α_1 . By proper selection of these factors, the light spread distribution angle α_1 may be selected

The light source **42** radiates light in the direction of the adjacent light coupler **32**. The light coupler **32** is preferably a Fresnel lens designed to spread the light that it receives from the light source **42** at the angle α_2 . The Fresnel lens also spreads light in the horizontal direction.

The light coupler **32** may be designed to provide a light spread that is close to that of collimated light as shown at **82**. The light spread from the light coupler **32** is preferably sufficient to cause total internal reflection off of the first and/or second surface sections **22, 24** and the light emitting surface **26** without emitting light through the light guide surface **23** by refraction.

In addition, the intensity of the light at **80** emitted at the light emitting surface **26** may be maximized by ensuring that all of the light internally incident upon the light guide surface **23** is internally reflected to be incident on the light emitting surface **26** such that it is emitted by refraction. Any light that is internally reflected at the light emitting surface **26** must reflect at an angle that will cause internal reflection off the light guide surface **23**.

Maximum intensity may be achieved by designing the light guide surface **23** to have selected angles between the first surface sections **22a-g** and the light emitting surface **26** as shown by angle Φ , and to have selected reflective angles between the first surface section and the second surface section as shown by angles Θ_1 through Θ_6 . The angles Θ_1 through Θ_6 formed by first and second surface sections **22**, **24** shown in Figure 3 are substantially the same. The angles Θ_1 through Θ_6 , however, may be different to cause total internal reflection of the light in a manner that varies the light spread distribution at α_1 as well as the appearance of the display device **10**. In one presently preferred embodiment, the angles Θ_1 through Θ_6 are at about 151° , however, different angles may be selected for different applications and for producing different effects as discussed above.

In addition to using different angles Θ_1 through Θ_6 , the number of surface sections on the light guide surface **23** may be varied. In Figure 3, there are seven first surface sections **22a-g** and six second surface sections **24a-f**. The number of surface sections may be different for specific applications to obtain desired effects, such as different appearances and intensities.

Other ways of obtaining selected light spread distributions α_1 includes using different substrate materials and light couplers **32**. The substrate material of the light

guide **20** may be chosen to vary the angle of refraction at the light emitting surface **26** as shown at **90**. The internal light spread distribution α_2 may also be adjusted by using different light couples **32** to obtain a selected light spread distribution α_1 .

Figures 4A and 4B show options for light couplers **32** that provide different
5 internal light distributions α_2 . Figure 4A shows a cross section of the light guide **20** in Figure 3 at section 4-4' showing round lenses **132a-f** mounted at the light source end **21**. The lenses in Figure 4A are preferably Fresnel lenses such as the Fresnel lens **132a**. Other lenses that may be used include divergent lenses, lens combinations such as a convergent and divergent lens combination, or any other spheric/aspheric lens
10 capable of being configured to provide the selected internal light spread distribution α_2 (shown in Figure 3).

The lenses may be adjusted to provide a light spread distribution α_2 using one of several techniques. The lenses may be adjusted to defocus the light source. The light source may also be adjusted to be offset from the center of the lenses. This is
15 shown in Figure 4A by a source point S offset by O relative to the center C of the lens **132b**.

Another technique for providing a light spread distribution is to provide a combination of convergent and divergent lenses that do not entirely collimate the light from the light source. The lenses may also be tilted relative to the sources.

20 Figure 4B shows the cross section of the light guide **20** having a plurality of lenses **134a-d** that are elliptical in shape. The advantage of using the elliptical lenses **134a-d** is that the amount of light radiated from the light source **42** (shown in Figure 3) may be maximized by capturing in the lenses **134a-d** light that would otherwise be directed between the lenses.

While the invention has been described in conjunction with presently preferred embodiments of the invention, persons of skill in the art will appreciate that variations may be made without departure from the scope and spirit of the invention. This true scope and spirit is defined by the appended claims, interpreted in light of the

5 foregoing.

THE EMBODIMENTS OF THE INVENTION IN WHICH AN EXCLUSIVE PROPERTY OR PRIVILEGE IS CLAIMED ARE DEFINED AS FOLLOWS:

1. A display device comprising:
 - at least one light source operable to radiate a light in a first direction;
 - at least one light coupler adjacent the at least one light source to receive the light, the at least one light coupler being operable to distribute the light in the first direction;
 - a light guide comprising a substrate material, the light guide having:
 - a light source end adjacent the at least one light coupler to receive the distributed light;
 - a light emitting surface extending from the light source end substantially along the first direction; and
 - a light guide surface extending from the light source substantially along the first direction, the light guide surface being opposite the light emitting surface; and
 - the light guide surface comprising a plurality of first surface sections, each first surface section separated by at least one of a plurality of second surface sections, the first surface sections extending at different angles from the second surface sections, at least one of the first and second surface sections being at a reflective angle to provide reflection of the light generated by the light source, the reflected light being emitted from the light emitting surface with a light distribution spread in a second direction.

2. The display device of Claim 1 wherein:
 - the first surface sections extend substantially parallel to the light emitting surface.

3. The display device of Claim 1 wherein:
 - at least one of the first surface sections extending at a second reflective angle from the light source end, the second reflective angle causing the light to reflect such that the reflected light from the at least one of the first surface sections diverges from the reflected light from the second surface sections.

4. The display device of Claim 1 wherein:
at least one of the first surface sections extending at a second reflective angle from the light source end, the second reflective angle causing the light to reflect such that the reflected light from the at least one of the first surface sections converges from the reflected light from the second surface sections.
- 5
5. The display device of Claim 1 wherein the substrate material may be a material selected from the group consisting of: acrylic, polycarbonate, plastic, or glass.
6. The display device of Claim 1 wherein the at least one light source includes light source devices selected from the group consisting of: light emitting diodes (LEDs), fiberoptic device outputs, tubular light sources, and incandescent lamps.
7. The display device of Claim 1 wherein the at least one light coupler includes light coupling devices selected from the group consisting of: a fresnel lens, a substantially round aspheric lens, a substantially round spheric lens, and a substantially elliptical aspheric lens.
8. The display device of Claim 1 comprising:
a plurality of light couplers arranged linearly; and
a plurality of light sources arranged linearly, each light source being positioned adjacent a corresponding light coupler.

5

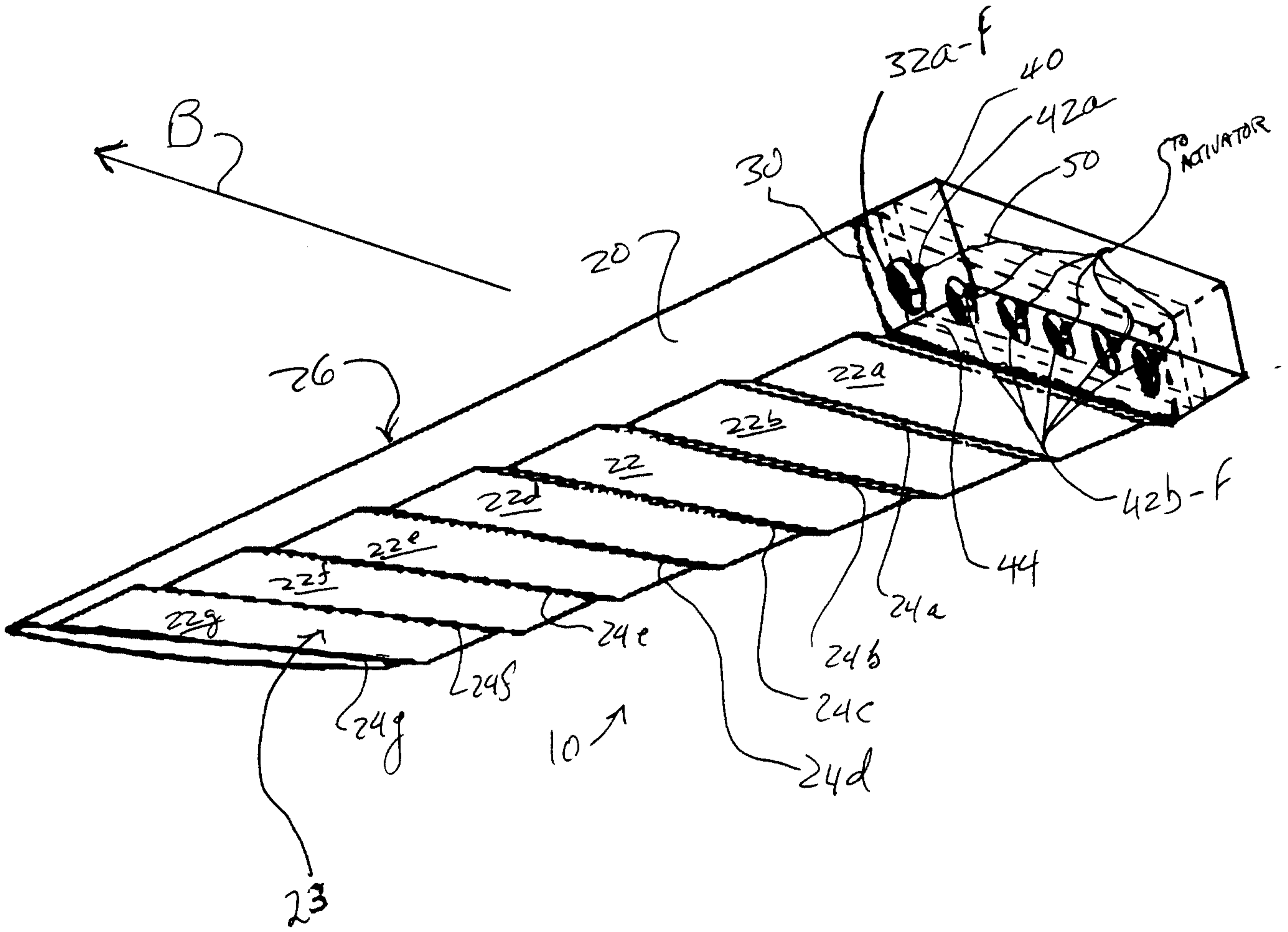

FIGURE 2

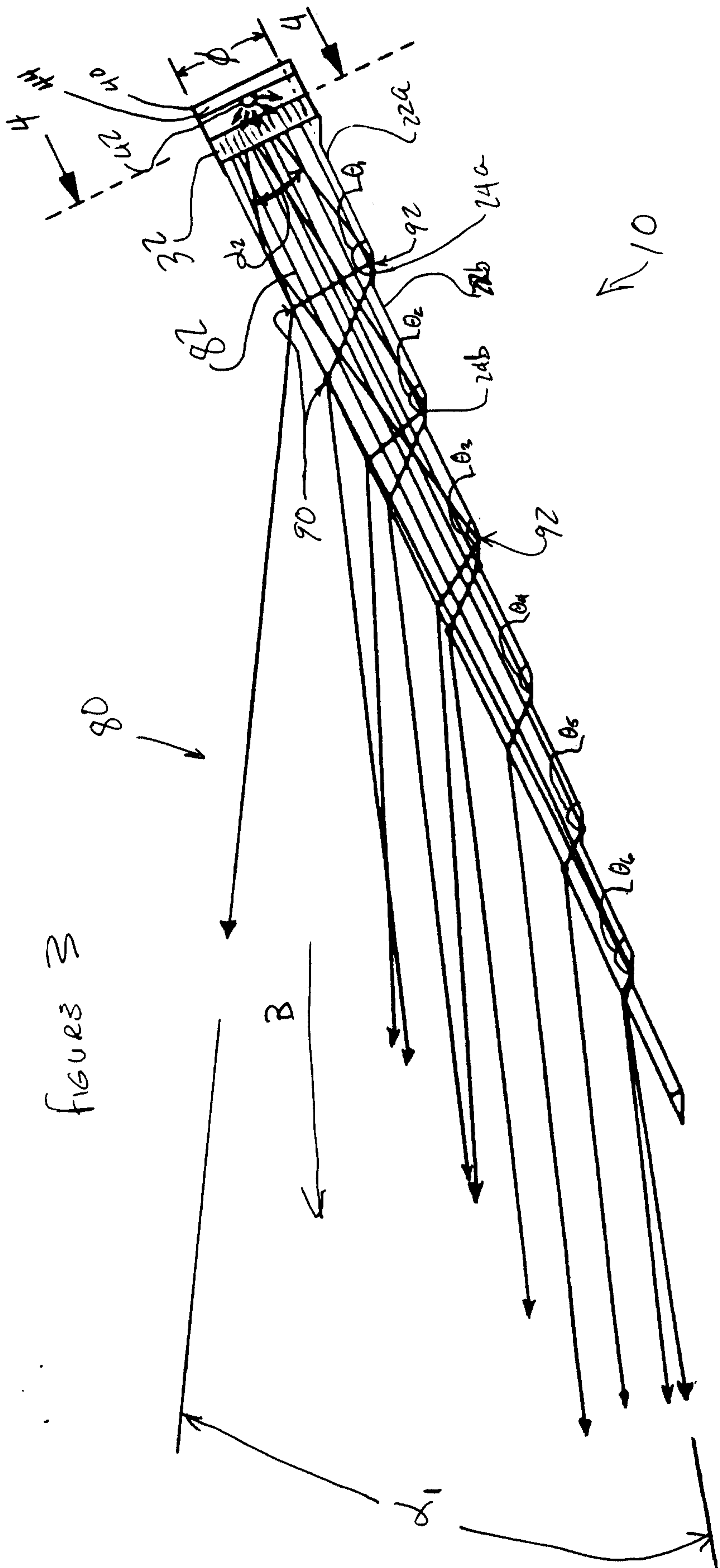

FIGURE 3

80

B

90

10

10

FIGURE 4A

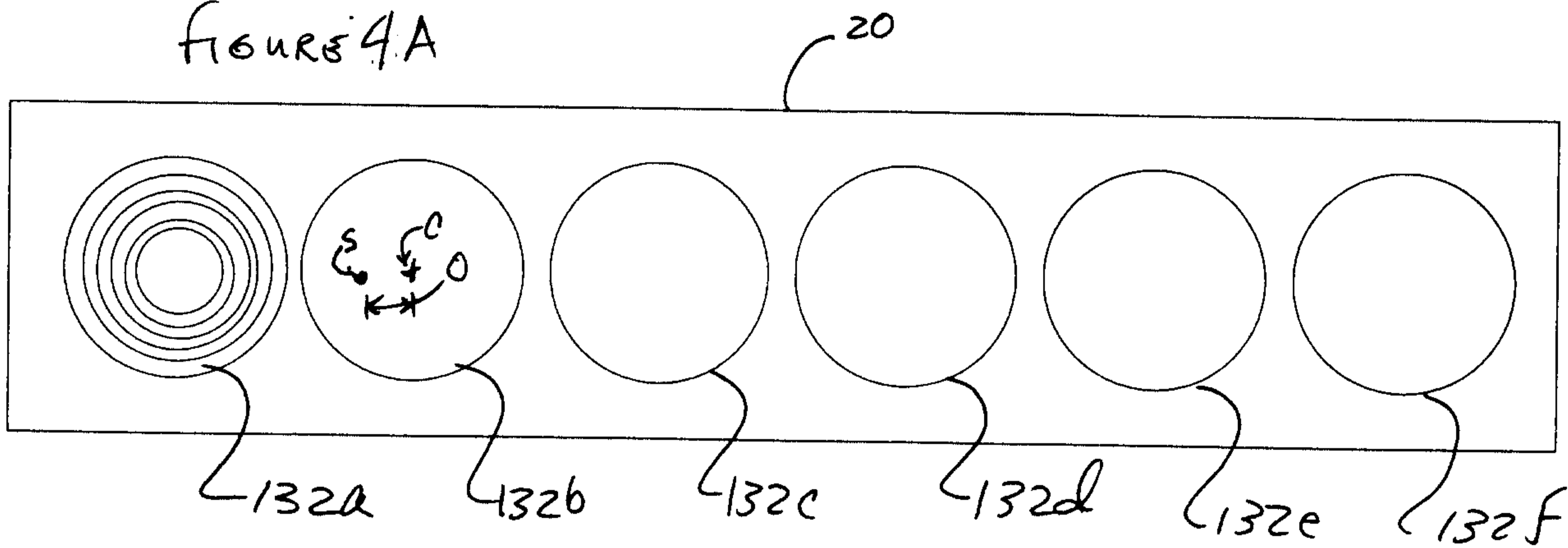

FIGURE 4B

