



- (51) International Patent Classification:
F03D 1/00 (2006.01) *F03D 11/00* (2006.01)
- (21) International Application Number:
PCT/EP2013/071079
- (22) International Filing Date:
9 October 2013 (09.10.2013)
- (25) Filing Language: English
- (26) Publication Language: English
- (30) Priority Data:
12382395.7 11 October 2012 (11.10.2012) EP
61/735,911 11 December 2012 (11.12.2012) US
- (71) Applicant: **ALSTOM RENOVABLES ESPAÑA, S.L.**
[ES/ES]; C/ Roc Boronat, 78, E-08005 Barcelona (ES).
- (72) Inventors: **BETRAN PALOMAS, Jaume**; C/ Aymerich,
1, 1^o 1^a, E-08172 Sant Cugat Del Vallès (ES). **MENAS-
ANCH DE TOBARUELA, Jorge**; C/ Salagarda, 45, E-
19171 Cabanillas Del Campo (ES).
- (74) Agent: **ZBM PATENTS- ZEA, BARLOCCI & MARK-
VARSDEN**; Pl. Catalunya, 1, E-08002 Barcelona (ES).
- (81) Designated States (unless otherwise indicated, for every
kind of national protection available): AE, AG, AL, AM,

AO, AT, AU, AZ, BA, BB, BG, BH, BN, BR, BW, BY,
BZ, CA, CH, CL, CN, CO, CR, CU, CZ, DE, DK, DM,
DO, DZ, EC, EE, EG, ES, FI, GB, GD, GE, GH, GM, GT,
HN, HR, HU, ID, IL, IN, IR, IS, JP, KE, KG, KN, KP, KR,
KZ, LA, LC, LK, LR, LS, LT, LU, LY, MA, MD, ME,
MG, MK, MN, MW, MX, MY, MZ, NA, NG, NI, NO, NZ,
OM, PA, PE, PG, PH, PL, PT, QA, RO, RS, RU, RW, SA,
SC, SD, SE, SG, SK, SL, SM, ST, SV, SY, TH, TJ, TM,
TN, TR, TT, TZ, UA, UG, US, UZ, VC, VN, ZA, ZM,
ZW.

- (84) Designated States (unless otherwise indicated, for every
kind of regional protection available): ARIPO (BW, GH,
GM, KE, LR, LS, MW, MZ, NA, RW, SD, SL, SZ, TZ,
UG, ZM, ZW), Eurasian (AM, AZ, BY, KG, KZ, RU, TJ,
TM), European (AL, AT, BE, BG, CH, CY, CZ, DE, DK,
EE, ES, FI, FR, GB, GR, HR, HU, IE, IS, IT, LT, LU, LV,
MC, MK, MT, NL, NO, PL, PT, RO, RS, SE, SI, SK, SM,
TR), OAPI (BF, BJ, CF, CG, CL, CM, GA, GN, GQ, GW,
KM, ML, MR, NE, SN, TD, TG).

Declarations under Rule 4.17:

- as to applicant's entitlement to apply for and be granted a patent (Rule 4.17(ii))
- as to the applicant's entitlement to claim the priority of the earlier application (Rule 4.17(iii))

[Continued on next page]

- (54) Title: A BLADE FOR A WIND TURBINE, AND A SERVICING UNIT FOR A BLADE

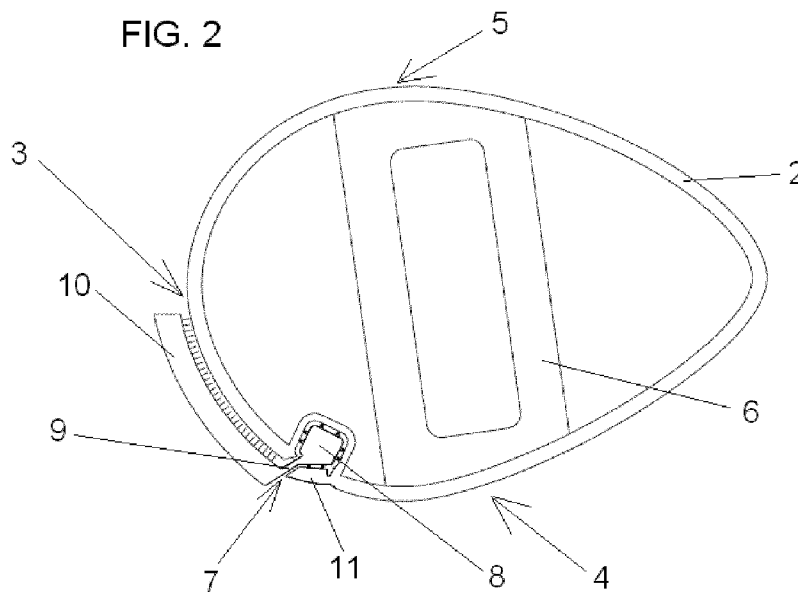

(57) Abstract: A blade for a wind turbine comprises a substantially hollow shell which comprises an opening which extends along at least part of the length of the blade, and a servicing unit displaceable along the blade shell, at least partly arranged inside the shell and comprising an arm adapted to project out of the shell through the opening.

Published:

— *with international search report (Art. 21(3))*

A blade for a wind turbine, and a servicing unit for a blade

This application claims the benefit of European Patent Application EP12382395.7 filed on October 11, 2012 and U.S. Provisional Patent
5 Application Ser. No. 61/735,911 filed on December 11, 2012.

The present invention relates to a blade for a wind turbine, and to a servicing unit for a blade.

10 BACKGROUND ART

During operation of a wind turbine, dirt and other materials may accumulate on the surface of the blades, especially on their leading edge: for example, flying insects may impact against the leading edge of the blade due to the
15 rotation and remain attached to it, or ice can form due to the weather conditions around the blades.

The build-up of dirt or ice on the leading edge of the blade may cause a change in the profile, and therefore in the aerodynamic forces acting on the
20 blade, such as to significantly reduce the power generated by the wind turbine, especially with strong winds; it may therefore be desirable to perform maintenance operations on the outer surface of the blade such as cleaning, wiping away insects or other dirt, removing ice, or servicing the surface of the blade in some other way.

25 Sometimes wind turbine blades may be cleaned by projecting water under pressure from the ground, or by hoisting cleaning staff up to the blade to perform the necessary operations; however, such solutions are far from being satisfactory.

30 From US2010/0003138 an apparatus is known for cleaning a leading edge of a rotor blade of a wind turbine. In this apparatus a cleaning device that may be displaced along the blade is maintained attached to the blade by magnets arranged inside the blade shell: the solution is relatively complex, and may
35 have associated safety issues.

The aim of the present invention is thus providing a blade and a servicing unit

for a blade that allow at least certain maintenance operations to be carried out on the blade surface in a safe and reliable way.

SUMMARY

According to one aspect, the present invention provides a blade for a wind turbine comprising

- 5 - a substantially hollow shell which comprises an opening which extends along at least part of the length of the blade, and
- a servicing unit displaceable along the blade shell, at least partly arranged inside the shell and comprising an arm adapted to project out of the shell through the opening.

10

These features allow carrying out cleaning or any other operations on the blade outer surface efficiently and safely: the presence of the opening in the shell allows arranging part of the servicing unit inside the blade and attaching the projecting arm to this part in a firm and safe way.

15

The blade may further comprising a closing gate which can move at least between a closed position in which it substantially overlaps the opening, and an open position in which it exposes the opening and allows the passage of the arm therethrough; the closing gate maintains closed the opening in the
20 shell at least when the servicing unit is not in use, thus reducing the impact of the opening on the performance of the blade.

The closing gate may be flexible; furthermore, it may be deformable locally, such that a longitudinal portion of the opening in the shell can be exposed
25 while the rest of the opening remains closed by the closing gate. This possibility of local deformation of the closing gate allows keeping closed most of the length of the closing gate even during operation of the servicing unit, while only a small length is opened to allow the arm of the servicing unit to extend therethrough.

30

The servicing unit may be adapted to cause shifting of at least part of the closing gate to the open position so as to expose at least part of the opening; according to some embodiments, the unit may be adapted to mechanically interfere with the closing gate such as to push open at least a portion of the
35 closing gate adjacent the servicing unit. This solution provides a simple and efficient way of causing the closing gate to open progressively when the servicing unit travels along the blade, for allowing the passage of the arm.

According to further aspects, the invention provides a servicing unit for a blade as disclosed, and a wind turbine comprising such a blade.

- 5 Additional objects, advantages and features of embodiments of the invention will become apparent to those skilled in the art upon examination of the description, or may be learned by practice of the invention.

BRIEF DESCRIPTION OF THE DRAWINGS

10

Particular embodiments of the present invention will be described in the following by way of non-limiting examples, with reference to the appended drawings, in which:

- 15 Figure 1 is a longitudinal view of a blade of a wind turbine, showing very schematically the arrangement of a servicing unit according to an embodiment of the invention and the driving system to displace the unit along the blade;

- 20 Figure 2 is a schematic cross sectional view of a blade with a servicing unit according to an embodiment;

Figure 3 is an enlarged view of a section of a blade according to an embodiment of the invention, where a servicing unit is present;

25

Figure 4 is a view similar to that of figure 3, of a section of a blade according to an embodiment of the invention, where the servicing unit is not present;

Figure 5 is a view similar to figure 4, showing a slightly different embodiment;

30

Figure 6 is a partial perspective view of a wind turbine blade according to another embodiment of the invention; and

- 35 Figure 7 is a schematic view of another embodiment of a blade with a servicing unit.

DETAILED DESCRIPTION OF EMBODIMENTS

Figures 1 and 2 show a wind turbine blade 1 comprising a shell 2, which is substantially hollow. The blade 1 has a leading edge 3, a pressure side 4 and a suction side 5. The blade 1 may also comprise an internal stiffening structure 6, inside the hollow shell 2.

The hollow shell 2 of the blade 1 may comprise an elongate opening 7 (not shown in figure 1) extending along at least part of the length of the blade 1.

10

As shown in figure 2, the opening 7 may be arranged in the pressure side 4 of the blade 1, such as to have a smaller effect on the performance of the blade.

A servicing unit 8 may be at least partly arranged inside the shell 2, and may comprise an arm 9 which is adapted to project out of the shell 2, through the opening 7; in some embodiments, it is arranged to extend in the proximity of the leading edge 3 of the blade.

15

The servicing unit 8 may be adapted to be displaced along the blade shell 2, with the arm 9 projecting from the opening 7; during this displacement, servicing operations may be performed outside the blade, typically on its outer surface, by attaching a suitable tool or equipment to arm 9, for example to the distal end of the arm, which may be provided with a coupling for attaching different kinds of tools, in particular tools for servicing the blade surface.

20

25

Figure 2 shows by way of example a cleaning tool 10 attached to the arm 9; for example, the leading edge 3 of the blade 1 may be wiped clean from dust and insects; similarly, ice may be scraped off or caused to melt using suitable means attached to the arm 9.

30

However, the arm 9 can carry or can be provided with any other maintenance or service tool, as needed. For example, a heating device may be attached to the arm 9 in order to heat the outer part of the blade.

35

The configuration of the arm 9 and/or of the tools intended to be attached to it may allow reaching different parts of the blade surface, and means may be

provided to power the tools if needed.

In some embodiments, the arm also may be moveable to a fold-away position in which it remains inside the shell and does not project from it; for example,
5 this may be achieved by attaching the arm 9 to the rest of the servicing unit 8 by means of a suitable connection.

In order to reduce the impact of the opening 7 on the performance of the blade 1, a closing gate 11 may be provided to close the opening 7 at least
10 when the servicing unit 8 is not in operation: the closing gate 11 can thus move between a closed position in which it substantially overlaps the opening to keep it closed, and an open position in which it exposes the opening 7 and allows the passage of the arm 9.

As will be explained below, it is also foreseen that the closing gate may adopt
15 the closed and the open position selectively along its length, i.e. that while one portion of the closing gate is in open position, another portion of the closing gate is in open position. For example, the closing gate 11 may be configured such as to allow maintaining open only a relatively small length of
20 the opening 7 around the projecting arm 9, while the rest of the opening 7 remains closed.

Figure 3 shows an enlarged, schematic view of an embodiment of a blade 1 with a shell 2, an opening 7, a closing gate 11, and a servicing unit 8
25 arranged inside the shell and having an arm 9 that can project from the opening 7. In the embodiment shown in this figure, the servicing unit 8 may comprise a carriage 13 that may travel along the blade guided in a channel 14, as will be described later on.

Figure 4 shows another section of a blade, where the servicing unit 8 is not
30 present, and with the closing gate 11 in closed position.

As shown in figure 4, the opening 7 and the closing gate 11 may be
35 configured in such a way that in the closed position the outer surface of the flap remains flush with the outer surface of the blade, such that the blade has no projections or recesses in the region of the closing gate. As shown in the alternative embodiment of figure 5, a distal edge of the closing gate 11 may

also comprise a projecting tab 110, intended to overlap the shell 2 in the closed position of the tab 110 and thus cover the narrow slit that may remain between the frame of the opening 7 and the closing gate 11.

5 The closing gate 11 may be pivotally attached to the shell 2, as shown in figures 3 and 4; for example it may be integrally formed with the shell 2, with a narrower section 12 forming a hinge to allow pivoting of the closing gate between the open and the closed position. Alternatively, the flap 11 may be independent of the shell, and may be made of a different material; in such
10 cases, it will be provided with suitable means for attachment to the shell 2.

Embodiments of the invention are foreseen in which the servicing unit 8 itself may cause the movement of at least part of the closing gate to the open position, so as to expose at least part of the opening 7.

15

Such an embodiment will be described with more detail with reference to figure 3, although it will be understood that other embodiments are also possible.

20 In the embodiment shown, the servicing unit comprises carriage 13, guided by the longitudinal channel 14 which has a suitable shape in cross section for providing this guiding action. Wheels 15 or similar elements may be placed between carriage 13 and channel 14 for a smoother movement. The servicing unit is shaped to mechanically interfere with the closing gate 11, such as to
25 exert a force on it and push it open: more particularly, the lower part of the carriage 13, which in operation is adjacent the opening 7 in the blade shell 2, has a shape protruding at least partly with respect to the opening 7, which pushes the closing gate 11 (at least adjacent the servicing unit 8) towards the open position, and thus allows the arm 9 of the servicing unit to protrude from
30 the opening 7.

In figure 3 the closing gate 11 may be flexible, and it may also be deformable locally, i.e. such that when pushed open at one position along its length, only a portion of it deforms, while the rest of the length does not deform: this
35 allows a longitudinal portion of the opening to be exposed (for example in correspondence with the service unit 8), while the rest of the opening remain closed by the flap 11, as shown in figure 4.

It will be understood that, in such a case, while the servicing unit 8 travels along the blade 1 the closing gate 11 will open progressively as the unit advances, allowing the arm 9 to travel while projecting from the shell 2, and closes again after the unit proceeds further.

Alternatively, instead of a closing gate 11 that is locally deformable such as described above, the blade may comprise, as shown in figure 6, several independent closing gate portions 11a, 11b, 11c,... arranged along the opening 7, such that one portion (11b in the figure) can be moved to the open position while the other portions (11a and 11c in the figure) remain closed.

A combined solution with several independent closing gates portions, wherein each portion may be partly deformable, is also possible.

In all cases, the closing gate 11 or closing gate portions 11a, 11b, 11c,... may also be opened by a driving unit, or by several driving units, instead of being opened by engagement with the servicing unit 8.

Such driving units may be functionally linked to the servicing unit 8, such that the latter causes the former to act on a portion of the closing gate appropriately during displacement of the servicing unit 8 along the blade 1, or they may be controlled by a control system to be synchronized with the servicing unit.

As explained in relation to figure 3, the carriage 13 of the servicing unit 8 may be guided on guiding means arranged inside the shell, such as the channel 14.

An alternative way of guiding the servicing unit 8 is providing a guide fixed to the internal stiffening structure 6 of the blade 1. Figure 7 shows an embodiment of a blade in which a servicing unit 8, for example the carriage 13 of the unit, is guided for displacement inside the shell 2 by a guiding beam 16 that is fixed to the stiffening structure 6. As shown, the carriage 13 may be configured to slide along the beam 16, and suitable rolling elements may be provided to enhance the movement.

A driving system 17 for displacing the servicing unit 8 along the blade 1 is schematically shown in figure 1. It will be appreciated that the driving system 17 is shown in the figure, although it may be completely housed inside the shell. The system 17 may comprise in a simple embodiment a driving motor 18, two pulleys 19 and 20 at the two ends of the intended travel path of the servicing unit 8, and a driving rope or cable 21 wound around the pulleys and to which the servicing unit 8, for example the carriage 13 of figures 3 and 7, is attached.

Alternative systems may be foreseen, such as a driving system actively driving the servicing unit 8 in one direction only, while the return travel may be caused by means of an elastic system, by gravity, or by other means.

A blade 1 according to embodiments of the invention may be provided with a parking position for the servicing unit 8, for example in the vicinity of the hub of the wind turbine rotor; in case the servicing unit 8 is adapted to mechanically interfere to push the closing gate open, as disclosed in some embodiments above, the parking position may be such that there is no such interference.

For example, the shape or arrangement of the guiding means (14 in figure 3 or 16 in figure 7) may vary when reaching the parking position, such that it guides the servicing unit 8 further inwards in the shell, out of engagement with the closing gate.

In embodiments of the invention it may be foreseen that the arm 9 of the servicing unit 8 may be folded or detached from the unit and withdrawn inside the shell 2 in the parking position; in this case, the arm 9 would not project through the opening when the servicing unit is not in use, and all the opening 7 may be closed in such circumstances.

A servicing unit 8 may be provided to be mounted on a blade 1 that has a suitable opening 7 as disclosed herein.

Blades comprising an opening 7 and a servicing unit 8 as disclosed herein can be mounted on a wind turbine to reduce the loss in generated power due to the accumulation of debris, ice or the like on the blade in a safe and simple

manner, and to reduce installation and maintenance costs.

Although only a number of particular embodiments and examples of the invention have been disclosed herein, it will be understood by those skilled in
5 the art that other alternative embodiments and/or uses of the invention and obvious modifications and equivalents thereof are possible. Furthermore, the present invention covers all possible combinations of the particular
10 embodiments described. Thus, the scope of the present invention should not be limited by particular embodiments, but should be determined only by a fair reading of the claims that follow.

CLAIMS

1. A blade for a wind turbine, comprising
- a substantially hollow shell which comprises an opening which extends
5 along at least part of the length of the blade, and
- a servicing unit displaceable along the blade shell, at least partly arranged
inside the shell and comprising an arm adapted to project out of the shell
through the opening.
- 10 2. A blade as claimed in claim 1, further comprising a closing gate which can
move at least between a closed position in which it substantially overlaps the
opening, and an open position in which it exposes the opening and allows the
passage of the arm therethrough.
- 15 3. A blade as claimed in claim 2, wherein the closing gate is pivotably
attached to the shell.
4. A blade as claimed in claim 3, wherein the closing gate is integrally formed
with the shell, with a narrower section forming a hinge.
- 20 5. A blade as claimed in any of claims 2 to 4, wherein the closing gate is
flexible.
6. A blade as claimed in claim 5, wherein the closing gate is deformable
25 locally, such that a longitudinal portion of the opening in the shell can be
exposed while the rest of the opening remains closed by the closing gate.
7. A blade as claimed in any of claims 2 to 4, wherein the closing gate
comprises several independent closing gate portions along the length of the
30 opening, such that one closing gate portion can shift to the open position
while other closing gate portions remain in the closed position.
8. A blade as claimed in any of claims 2 to 7, wherein the distal edge of the
closing gate comprises a projecting tab intended to overlap the shell in the
35 closed position of the closing gate.
9. A blade as claimed in any of the preceding claims, wherein the servicing

unit comprises a carriage which is arranged substantially inside the shell and displaceable along the blade, and to which said arm is attached.

5 10. A blade as claimed in claim 9, wherein the carriage is guided on guiding means arranged inside the shell.

10 11. A blade as claimed in claim 10, wherein the shell is provided with an internal stiffening structure, and the guiding means comprise a guide fixed to the stiffening structure.

15 12. A blade as claimed in claim 10 wherein the shell is provided with an internal longitudinal channel at least along part of the blade, said channel having a shape in cross section which is adapted to serve as a guide to the carriage.

15 13. A blade as claimed in any of claims 2 to 12, wherein the servicing unit is adapted to cause shifting of at least part of the closing gate to the open position so as to expose at least part of the opening.

20 14. A blade as claimed in claim 13, wherein the servicing unit is adapted to mechanically interfere with the closing gate such as to push open at least a portion of the closing gate adjacent the servicing unit.

25 15. A blade as claimed in claim 14, wherein the blade comprises a parking position for the servicing unit, whereby when the servicing unit is in said parking position it doesn't interfere with the closing gate.

30 16. A blade as claimed in any of the preceding claims, wherein the arm is moveable between a deployed position in which it projects from the shell through the opening and a fold-away position in which it remains inside the shell.

35 17. A blade as claimed in any of the preceding claims, wherein a blade surface servicing tool is attached at a distal end of the arm.

18. A blade as claimed in any if the preceding claims, wherein the arm is arranged to extend in the proximity of the leading edge of the blade.

19. A blade as claimed in any of the preceding claims, wherein the opening in the shell is arranged in the pressure side of the blade.
- 5 20. A servicing unit for a blade as claimed in any of the preceding claims.
21. A wind turbine comprising a blade as claimed in any of claims 1 to 19.

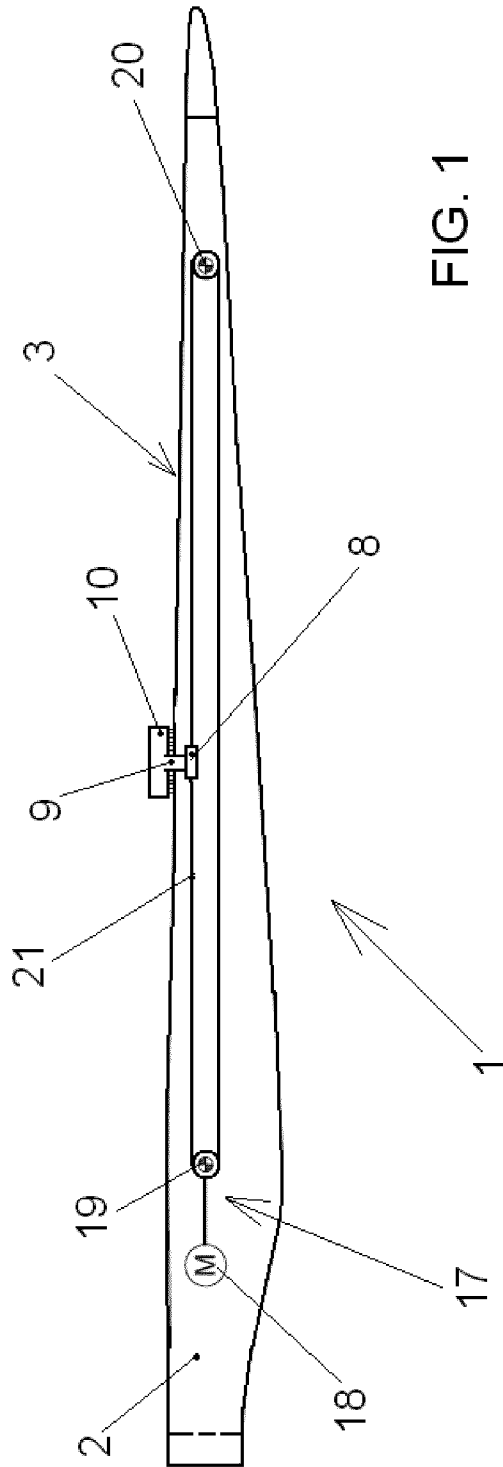

FIG. 1

FIG. 2

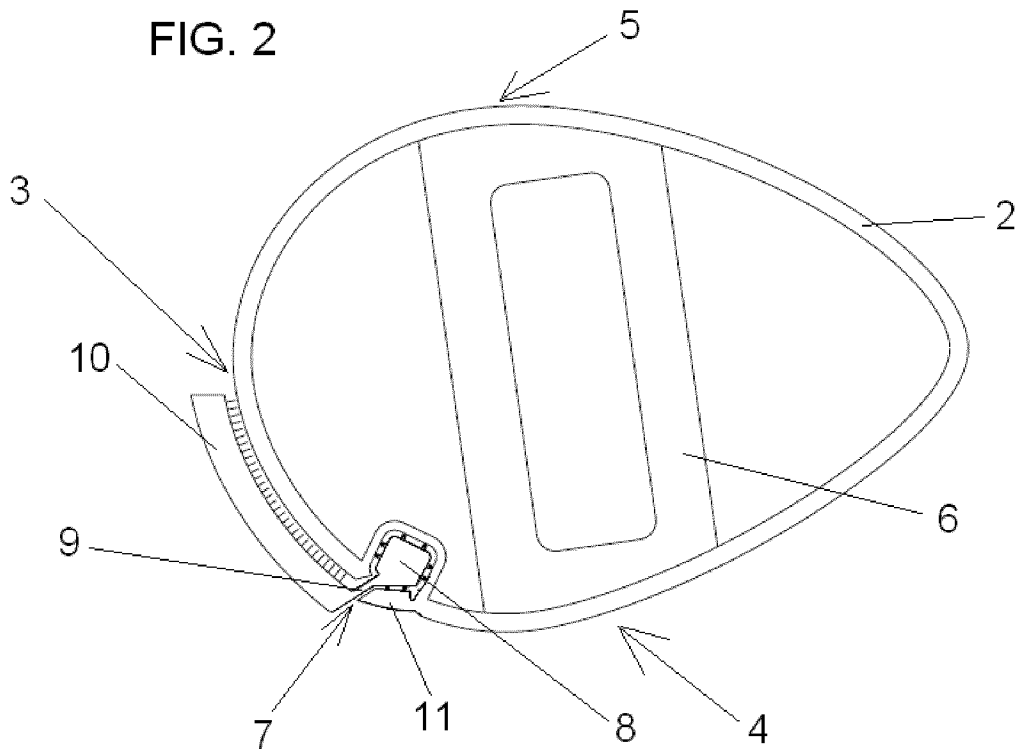

FIG. 3

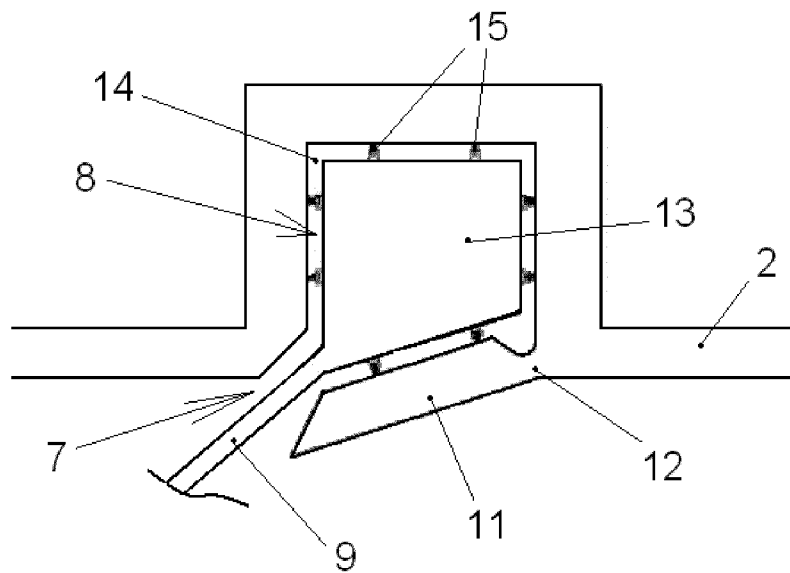

FIG 4

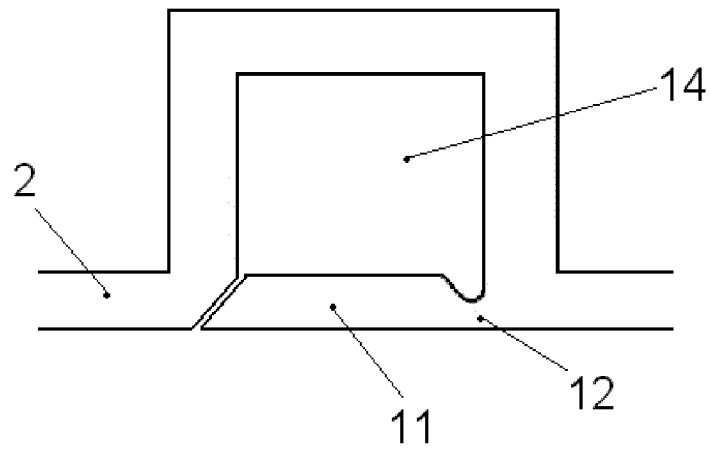
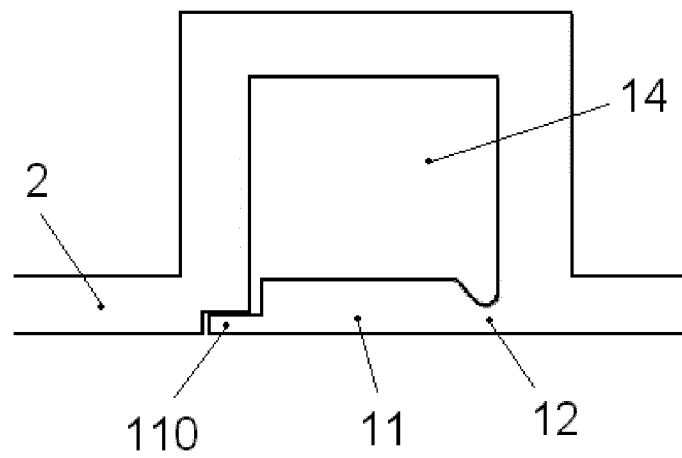
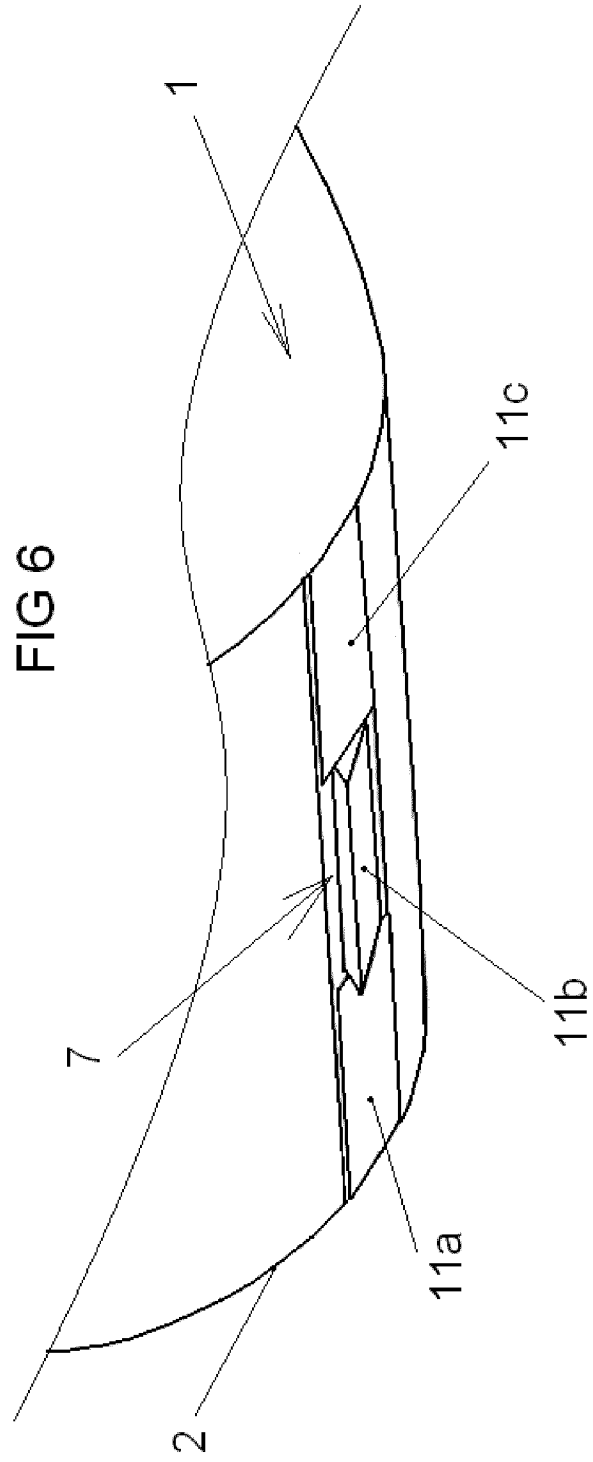
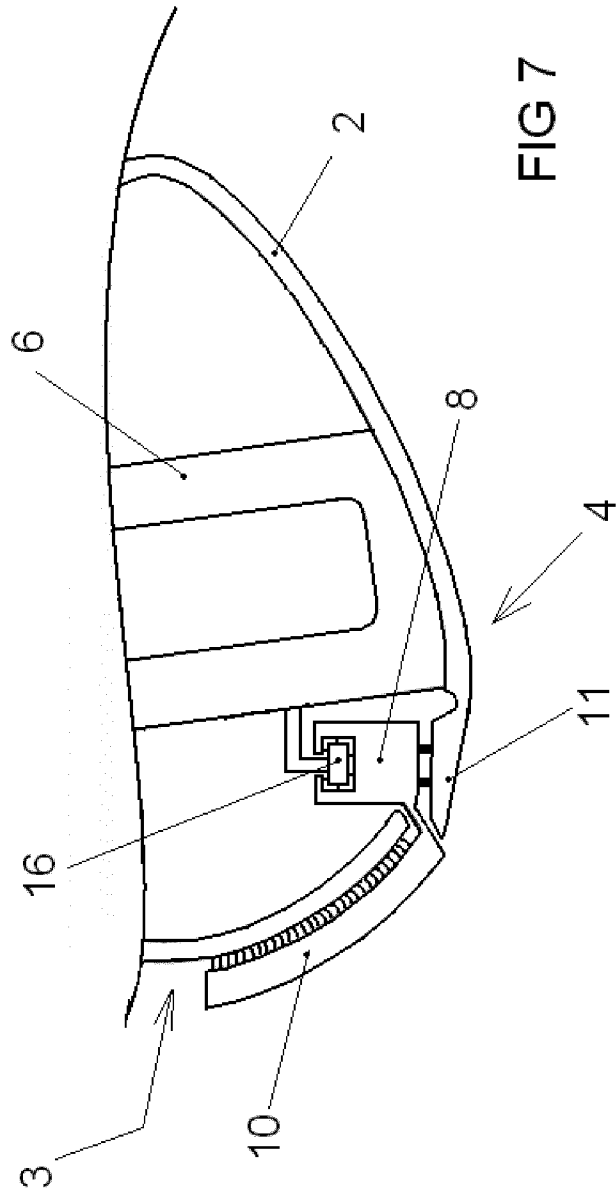

FIG 5







INTERNATIONAL SEARCH REPORT

International application No
PCT/EP2013/071079

A. CLASSIFICATION OF SUBJECT MATTER
INV. F03D1/00 F03D11/00
ADD.
According to International Patent Classification (IPC) or to both national classification and IPC

B. FIELDS SEARCHED
Minimum documentation searched (classification system followed by classification symbols)
F03D
Documentation searched other than minimum documentation to the extent that such documents are included in the fields searched

Electronic data base consulted during the international search (name of data base and, where practicable, search terms used)
EPO-Internal, WPI Data

C. DOCUMENTS CONSIDERED TO BE RELEVANT

| Category* | Citation of document, with indication, where appropriate, of the relevant passages | Relevant to claim No. |
|-----------|--|----------------------------|
| X | JP 2002 115646 A (MITSUBISHI HEAVY IND LTD) 19 April 2002 (2002-04-19) figures 6,7,10 paragraphs [0015], [0016], [0018], [0022], [0033], [0034], [0035] ----- | 1,9-11, 17,18, 20,21 |
| A | GB 740 177 A (ARMSTRONG WHITWORTH CO ENG) 9 November 1955 (1955-11-09) figure 1 page 1, line 9 - line 80 ----- | 1-21 |
| A | US 2010/003138 A1 (SIEBERS THOMAS [DE] ET AL) 7 January 2010 (2010-01-07) cited in the application figures 4-8 paragraphs [0004] - [0006], [0023], [0025], [0035] - [0039] ----- -/-- | 1-21 |

Further documents are listed in the continuation of Box C.

See patent family annex.

* Special categories of cited documents :

- "A" document defining the general state of the art which is not considered to be of particular relevance
- "E" earlier application or patent but published on or after the international filing date
- "L" document which may throw doubts on priority claim(s) or which is cited to establish the publication date of another citation or other special reason (as specified)
- "O" document referring to an oral disclosure, use, exhibition or other means
- "P" document published prior to the international filing date but later than the priority date claimed

- "T" later document published after the international filing date or priority date and not in conflict with the application but cited to understand the principle or theory underlying the invention
- "X" document of particular relevance; the claimed invention cannot be considered novel or cannot be considered to involve an inventive step when the document is taken alone
- "Y" document of particular relevance; the claimed invention cannot be considered to involve an inventive step when the document is combined with one or more other such documents, such combination being obvious to a person skilled in the art
- "&" document member of the same patent family

| | |
|--|--|
| Date of the actual completion of the international search 29 October 2013 | Date of mailing of the international search report 06/11/2013 |
| Name and mailing address of the ISA/ European Patent Office, P.B. 5818 Patentlaan 2 NL - 2280 HV Rijswijk Tel. (+31-70) 340-2040, Fax: (+31-70) 340-3016 | Authorized officer Rakotonanahary, S |

INTERNATIONAL SEARCH REPORT

International application No
PCT/EP2013/071079

| C(Continuation). DOCUMENTS CONSIDERED TO BE RELEVANT | | |
|--|---|-----------------------|
| Category* | Citation of document, with indication, where appropriate, of the relevant passages | Relevant to claim No. |
| A | EP 1 500 815 A1 (NATENCO NATURAL ENERGY CORP GM [DE] WINDREICH AG [DE]) 26 January 2005 (2005-01-26) figures 3,4 paragraphs [0001] - [0011], [0017] ----- | 1-21 |
| A | US 2010/132137 A1 (EGGLESTON ERIC [US]) 3 June 2010 (2010-06-03) figures 1-3 paragraphs [0005], [0006], [0015], [0019] ----- | 1-21 |
| A | US 2012/134812 A1 (NANUKUTTAN BIJU [IN] ET AL) 31 May 2012 (2012-05-31) figures 8-14 paragraphs [0053] - [0057], [0061] ----- | 2-8 |

INTERNATIONAL SEARCH REPORT

Information on patent family members

| |
|---|
| International application No PCT/EP2013/071079 |
|---|

| Patent document cited in search report | Publication date | Publication date | Patent family member(s) | Publication date |
|--|------------------|------------------|-------------------------|------------------|
| JP 2002115646 | A | 19-04-2002 | NONE | |
| ----- | | | | |
| GB 740177 | A | 09-11-1955 | NONE | |
| ----- | | | | |
| US 2010003138 | A1 | 07-01-2010 | CA 2670252 A1 | 03-01-2010 |
| | | | CN 101619707 A | 06-01-2010 |
| | | | EP 2141354 A2 | 06-01-2010 |
| | | | US 2010003138 A1 | 07-01-2010 |
| ----- | | | | |
| EP 1500815 | A1 | 26-01-2005 | AT 553858 T | 15-05-2012 |
| | | | DE 10332876 A1 | 10-02-2005 |
| | | | DK 1500815 T3 | 23-07-2012 |
| | | | EP 1500815 A1 | 26-01-2005 |
| | | | ES 2385980 T3 | 06-08-2012 |
| | | | PT 1500815 E | 30-05-2012 |
| | | | SI 1500815 T1 | 28-09-2012 |
| ----- | | | | |
| US 2010132137 | A1 | 03-06-2010 | CA 2708800 A1 | 17-01-2011 |
| | | | CN 101956652 A | 26-01-2011 |
| | | | EP 2275670 A2 | 19-01-2011 |
| | | | US 2010132137 A1 | 03-06-2010 |
| ----- | | | | |
| US 2012134812 | A1 | 31-05-2012 | NONE | |
| ----- | | | | |