



US00D649934S

(12) **United States Design Patent**
Shioiri et al.

(10) **Patent No.:** **US D649,934 S**

(45) **Date of Patent:** **** Dec. 6, 2011**

(54) **ELECTRIC MOTOR**

(75) Inventors: **Mitsuaki Shioiri**, Nagano Prefecture
(JP); **Syougo Yoda**, Nagano Prefecture
(JP); **Akio Miyahara**, Nagano Prefecture
(JP); **Ikuo Takeshita**, Nagano Prefecture
(JP)

(73) Assignee: **Sanyo Denki Co., Ltd.**, Tokyo (JP)

(**) Term: **14 Years**

(21) Appl. No.: **29/394,710**

(22) Filed: **Jun. 21, 2011**

(30) **Foreign Application Priority Data**

Dec. 22, 2010 (JP) 2010-030710

(51) **LOC (9) Cl.** **13-01**

(52) **U.S. Cl.** **D13/112**

(58) **Field of Classification Search** D13/112,
D13/113, 114, 122, 199; D15/3, 5, 199;
74/606 R, 609; 310/10, 40 R, 42, 51, 52,
310/58, 64, 71, 80, 83, 85, 88, 89, 91, 109,
310/236, 239, 254; 318/245, 255; 322/16,
322/39; 361/688, 704, 709; 29/596-598

See application file for complete search history.

(56) **References Cited**

U.S. PATENT DOCUMENTS

D194,910 S * 4/1963 Lindt et al. D13/112
D203,182 S * 12/1965 Otto D13/114
D213,563 S * 3/1969 Mabuchi D13/112
D287,715 S * 1/1987 Pittman et al. D13/112
D306,009 S * 2/1990 Mintz et al. D13/112
4,933,582 A * 6/1990 Hata et al. 310/154.14
4,988,905 A * 1/1991 Tolmie, Jr. 310/68 B
D336,890 S * 6/1993 Hirose et al. D13/112
D424,516 S * 5/2000 Friedrichsen D13/112

D457,492 S * 5/2002 Kim D13/110
6,717,302 B2 * 4/2004 Kolloff et al. 310/71
D557,210 S * 12/2007 Liu D13/112
D597,943 S * 8/2009 Lin et al. D13/112
D601,958 S * 10/2009 Huan et al. D13/112
7,687,945 B2 * 3/2010 Matin et al. 310/64

OTHER PUBLICATIONS

“Design News”, published May 9, 1994 in the U.S., vol. 49-9; a Cahners Publication, 5 pages.

* cited by examiner

Primary Examiner — Derrick Holland

(74) *Attorney, Agent, or Firm* — Rankin, Hill & Clark LLP

(57) **CLAIM**

We claim the ornamental design for an electric motor, as shown and described.

DESCRIPTION

FIG. 1 is a front side elevation view of an electric motor embodying our design;

FIG. 2 is a rear side elevation view thereof;

FIG. 3 is a right side elevation view thereof;

FIG. 4 is a left side elevation view thereof;

FIG. 5 is a top plan view thereof;

FIG. 6 is a bottom plan view thereof;

FIG. 7 is a cross sectional view as taken along 7-7 line in FIG. 4, omitting the interior mechanism; and,

FIG. 8 is a perspective view of the electric motor.

The broken lines shown represent unclaimed subject matter and form no part of the claim. Where broken lines abut a claimed surface it is understood that those broken lines represent an unclaimed boundary between claimed and unclaimed surfaces. None of the broken lines form any part of the claimed design.

1 Claim, 8 Drawing Sheets

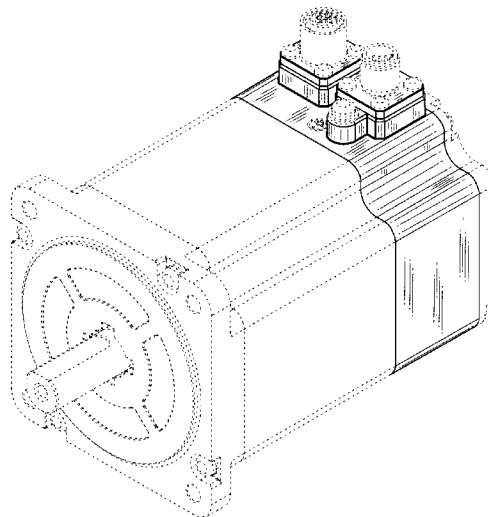

FIG. 1

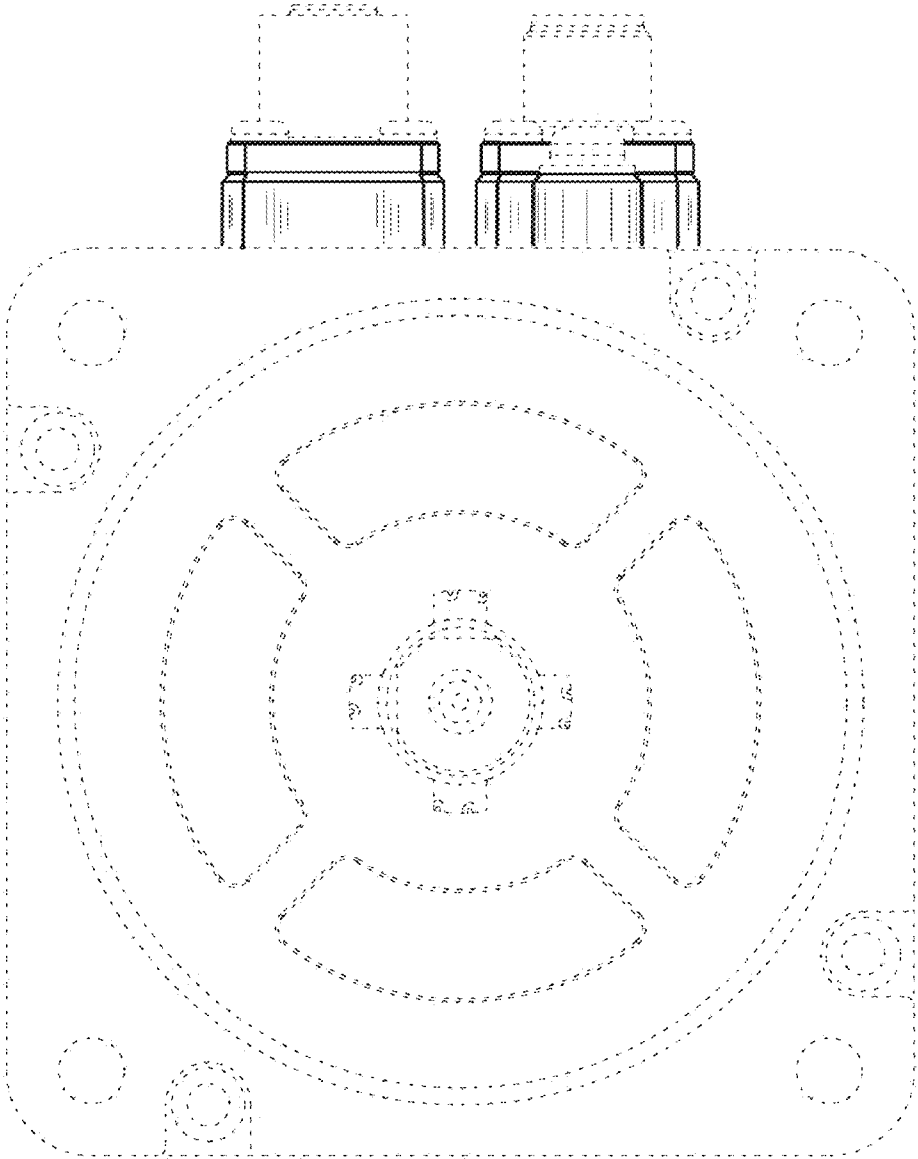

FIG.2

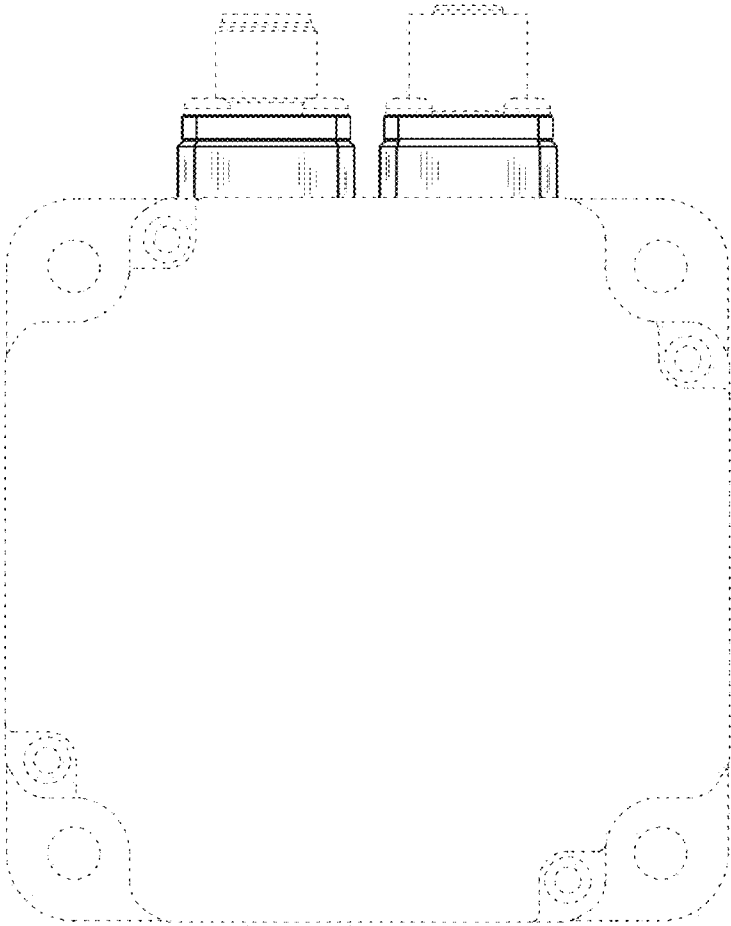

FIG. 3

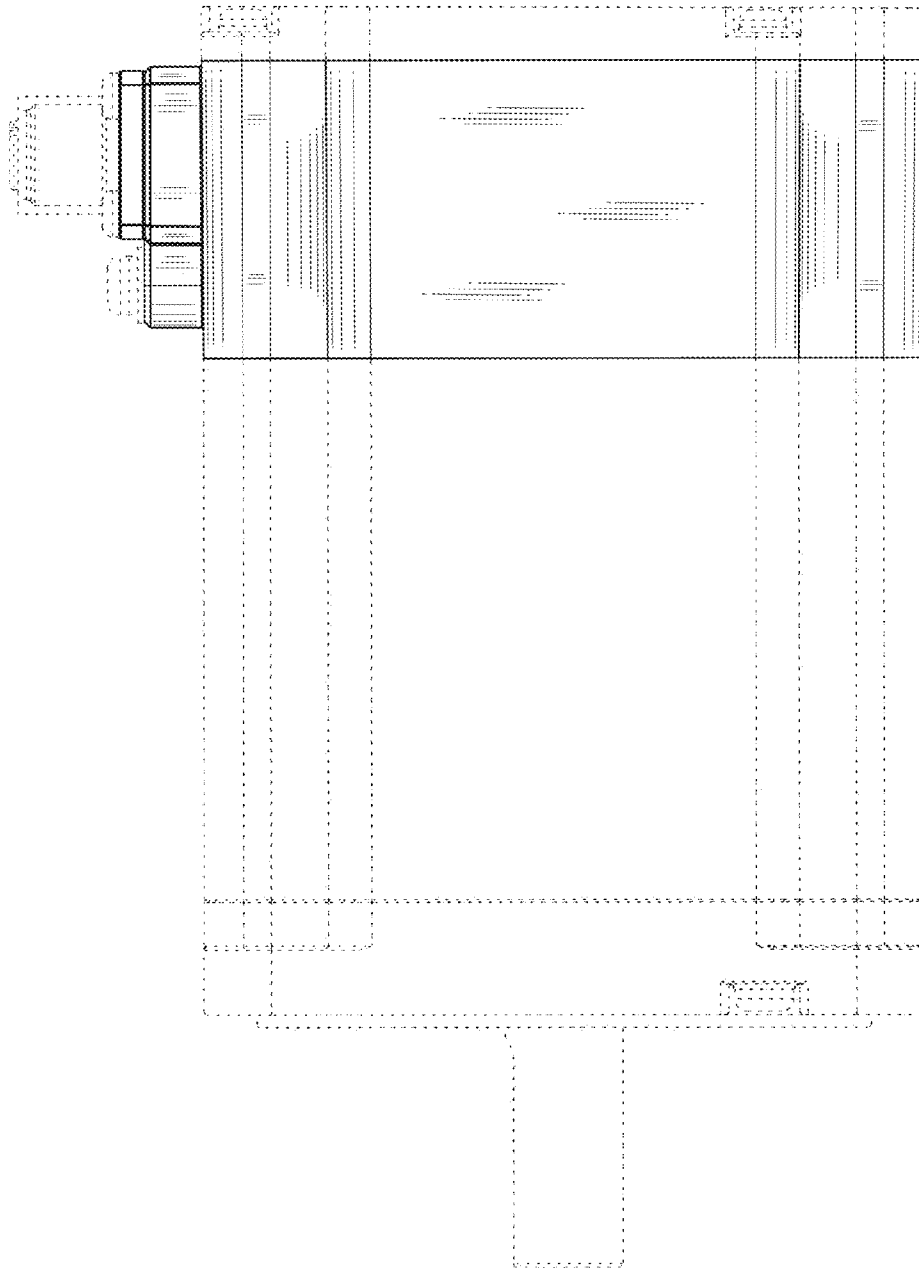

FIG.4

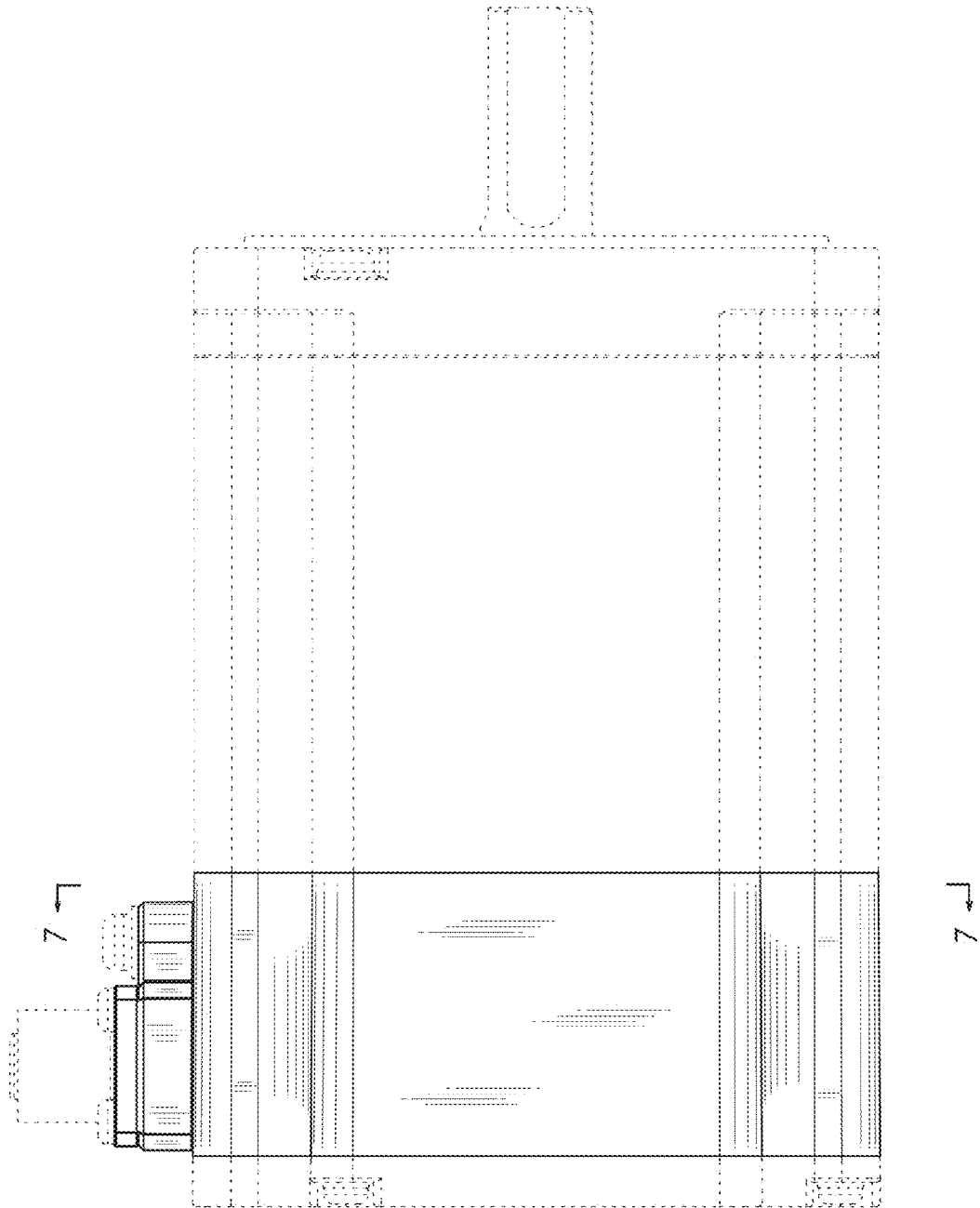

FIG.5

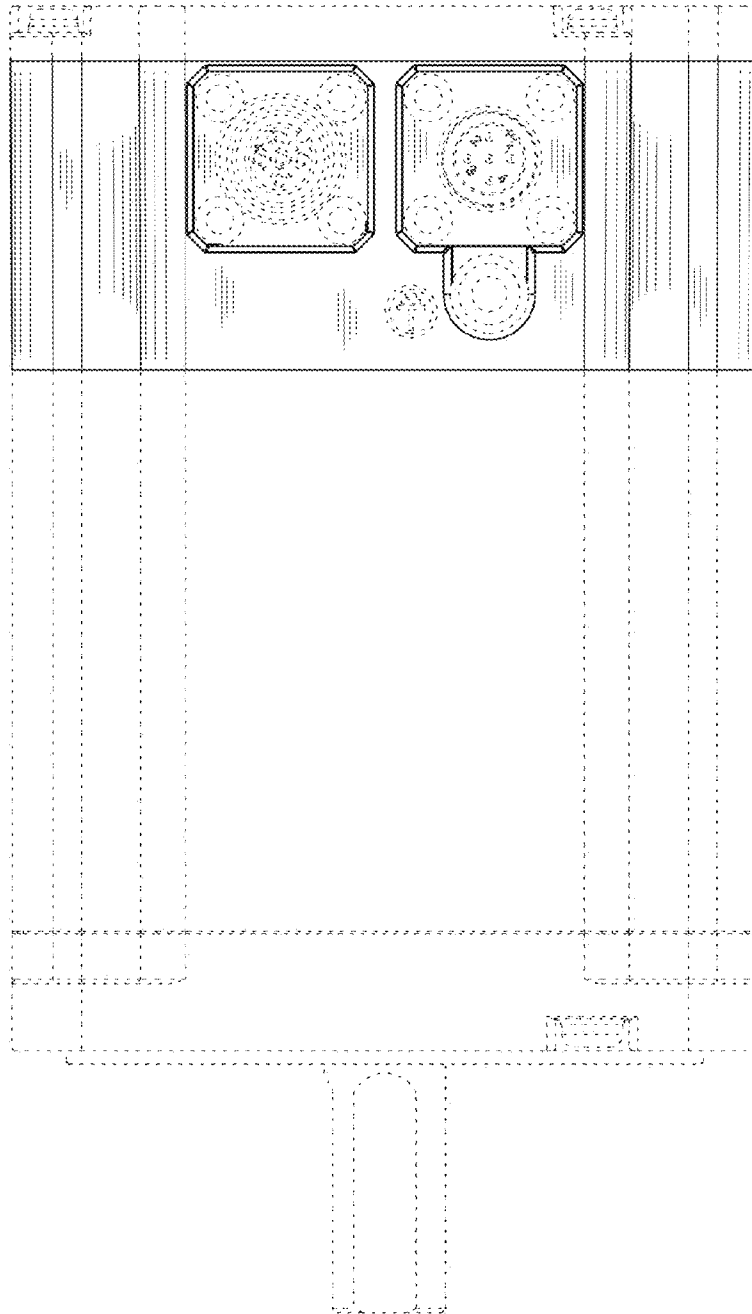

FIG. 6

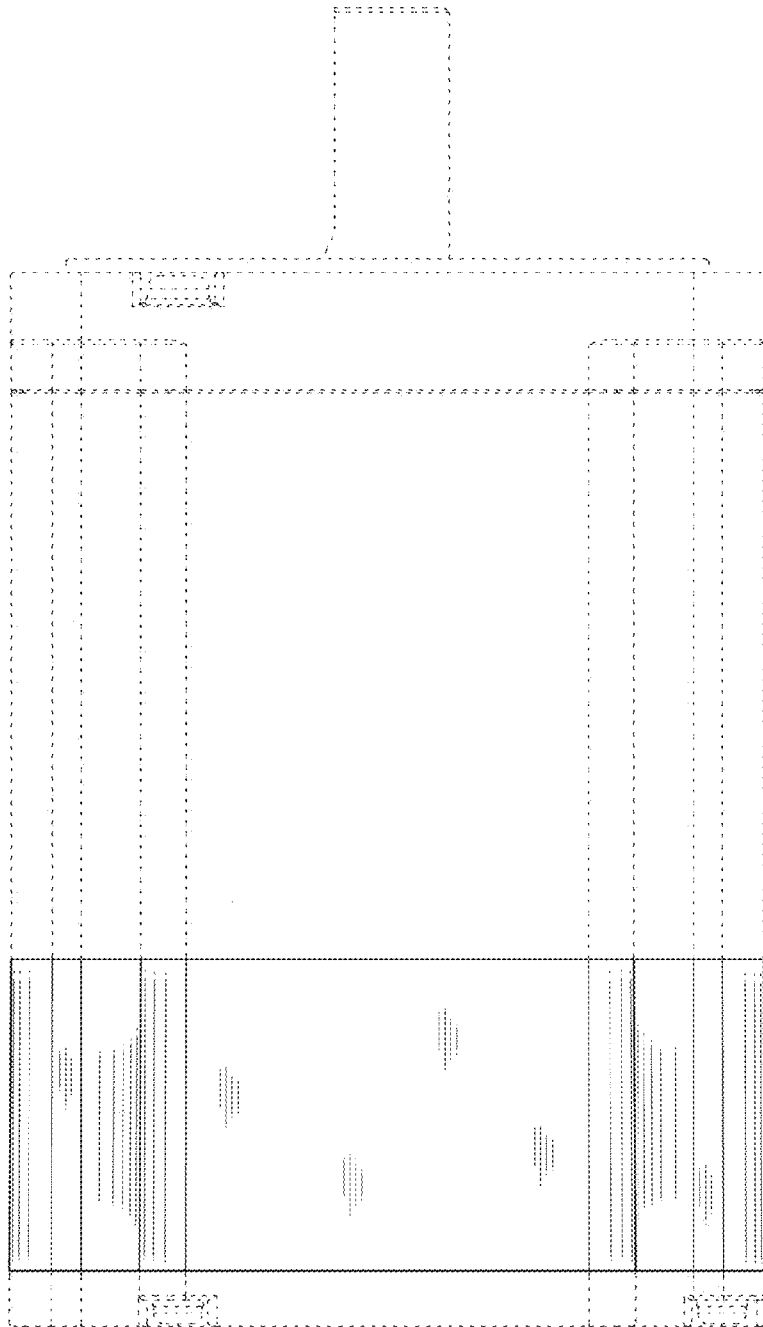

FIG.7

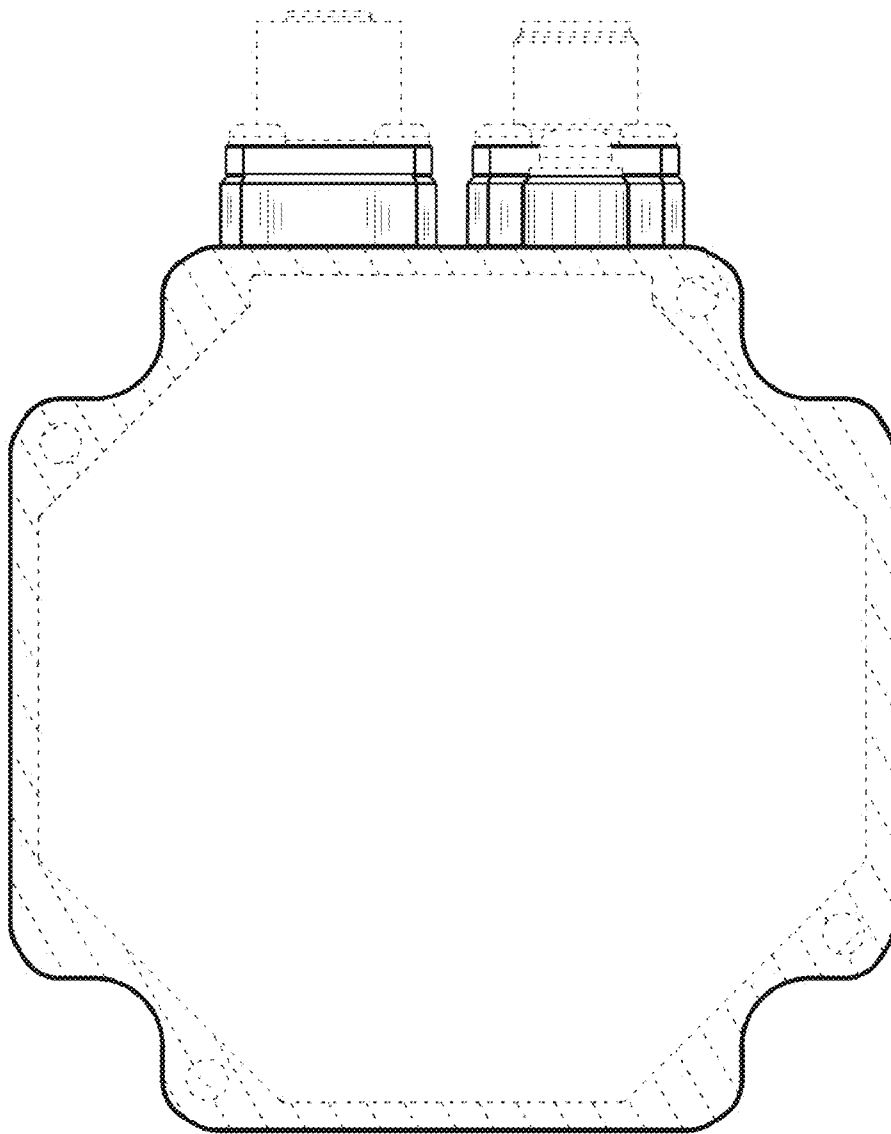

FIG.8

