

H. J. FOSTER.  
CLAMP FOR CONCRETE FORMS.  
APPLICATION FILED AUG. 14, 1919.

1,376,614.

Patented May 3, 1921.

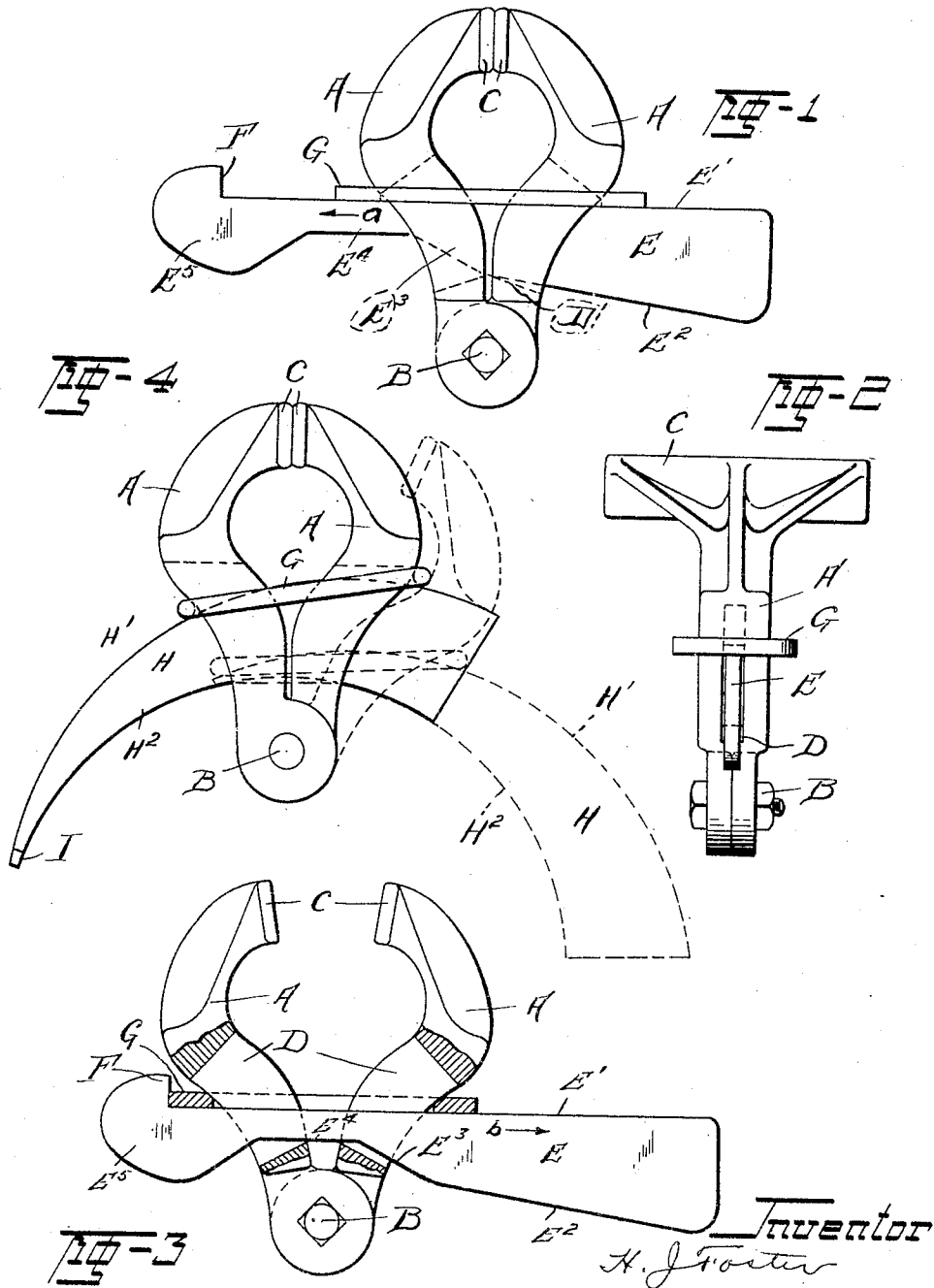

Inventor  
H. J. Foster

By Hew Smith Brock & West  
Attys.

# UNITED STATES PATENT OFFICE.

HENRY J. FOSTER, OF CLEVELAND, OHIO, ASSIGNOR TO THE HYDRAULIC PRESSED STEEL COMPANY, OF CLEVELAND, OHIO, A CORPORATION OF OHIO.

## CLAMP FOR CONCRETE-FORMS.

1,376,614.

Specification of Letters Patent.

Patented May 3, 1921.

Application filed August 14, 1919. Serial No. 317,452.

*To all whom it may concern:*

Be it known that I, HENRY J. FOSTER, a citizen of the United States, residing at Cleveland, in the county of Cuyahoga and State of Ohio, have invented a certain new and useful Improvement in Clamps for Concrete-Forms, of which the following is a full, clear, and exact description, reference being had to the accompanying drawings.

This invention relates generally to clamps and the more particularly to one designed for use in connection with concrete forms.

In constructing cement or concrete columns, it is customary to employ sheet metal forms composed of two or more sections and various types of clamping or binding devices have been employed for connecting the sections of the form together, and in some instances the sheet metal forms have been provided with outwardly extending contacting flanges which are clamped together, and it is in connection with a concrete form of this type that the present design of clamp is intended to be used.

The object of the invention is to provide an exceedingly simple and highly efficient form of clamp which can be quickly and easily applied to the meeting edges of the concrete form, and which can be as quickly opened and removed when not further required.

Another object of the invention is to provide a clamp in which the parts are so constructed that, no damage or impairment will occur when subjected to the usual hammering operations incidental to use.

With these various objects in view, the invention consists in the novel features of construction and arrangements hereinafter fully described and set forth in the appended claims.

In the drawings forming a part of this specification Figure 1 is an elevation of the clamp constructed in accordance with my invention, said clamp being illustrated in its closed or locked position; Fig. 2 is a side view of the same; Fig. 3 is a sectional elevation, the clamp being shown unlocked and opened and Fig. 4 is a view showing a slightly modified form of wedge, the clamp being shown closed in full lines and opened in dotted lines.

In the practical embodiment of the invention I employ two arms A connected at one end by means of a suitable pivot such as a bolt B, having a nut B' screwed thereon.

It is obvious however that instead of a bolt and nut, a rivet could be employed for providing the pivotal connection between the arms.

At the opposite end of each arm there is provided a jaw C, said jaws extending at right angles to the arms as most clearly shown and the opposing faces of these jaws are shaped for contact with each other. The arms are bowed or curved outwardly in reverse direction as shown thereby providing a considerable space between the said arms just within or to the rear of the contacting jaws.

Each arm is provided with a slot, aperture or opening D, intermediate its ends, said apertures or openings being in alignment with each other when the arms are connected together and working in said openings is a wedge E, which is provided at its narrow or reduced end with a hook or enlargement F.

Surrounding the arms A is a link G, said link being adapted to contact with the arms and also with the wedge, said link and wedge cooperating to lock the jaws together, and when the wedge is driven home as shown in Figs. 1, 2 and 4, the link will be brought into locked relation with the arms and the jaws of the arms will be held either in contact with each other or in contact with the members to be clamped, and which are interposed between the jaws.

It will be noted that the inner ends of the slots or openings D are preferably made slanting as shown at D' to facilitate the manipulation of the wedge E.

This wedge is preferably made by a straight edge E' which contacts with the link G, while the opposite edge E<sup>2</sup> is made slightly oblique and then more abruptly oblique as shown at E<sup>3</sup> and substantially parallel at E<sup>4</sup> with the straight edge E' and at the extreme ends somewhat enlarged as shown at E<sup>5</sup> and provided with the hook F which extends at right angles from the straight edge E'.

When the wedge is driven in the direction indicated by the arrow *a* the link will be forced up into contact with the arms, but when the wedge is driven into reverse direction as indicated by the arrow *b* the hook or head F will engage the link G and will carry the same downwardly and to one side, thereby permitting the arms and jaws to be separated sufficiently to remove the clamp

from the form; and by virtue of the cutout or reëntrant portion in the wedge, ample space will be provided for the wedge and link to approach the pivotal point sufficiently to permit the considerable separation of the arms and jaws.

In the construction shown in Fig. 4 a slightly modified form of wedge H is employed, the edges H' and H<sup>2</sup> being the arcs of eccentric circles which meet at the extreme narrow end of the wedge which is upset as shown at 1 to provide a suitable head or stop to prevent the withdrawal of the wedge.

The head 1, as well as the enlarged end E<sup>5</sup>, of the wedge E provide suitable points against which a blow can be struck when it is desired to drive back the wedge and unlock the clamp.

The arms and jaws can be reinforced in any suitable manner, and it is obvious that certain changes and modifications may be made in various parts without departing from the principle of the invention as defined in the following claims.

Having thus described my invention, what I claim is:

1. A clamp of the kind described, comprising a pair of arms pivotally connected at their ends and provided with jaws at their free ends, said arms being slotted intermediate their ends, a link surrounding said arms between the jaws and pivot, and a wedge working in said slots and engaging said link.

2. The combination with a pair of piv-

otally connected arms provided with jaws at their free ends, of a link surrounding said arms, and a wedge movable through said arms and adapted to engage said link and arms, said wedge being provided with means to prevent its withdrawal from the arms.

3. The combination with a pair of pivotally connected arms having clamping jaws at their free ends, said arms being slotted intermediate their ends, of a link surrounding said arms, and a wedge working through said arms said wedge having a head or enlargement at its narrow end, the edge of said wedge adjacent the pivotal ends of the arms being shaped to permit the approach of the link to the pivot and whereby wide separation of the arms and jaws is permitted.

4. A clamp of the kind described comprising a pair of pivotally connected arms slotted intermediate their ends, a link surrounding said arms, and a wedge working through said arms and adapted to engage said link, said wedge being provided at its narrow end with means to prevent the withdrawal of said wedge from the arms.

5. A clamp of the kind described comprising a pair of pivotally connected arms provided with clamping jaws at their free ends, means encircling said arms intermediate their ends and wedging means adapted to engage said arms and said encircling means to lock the arms and jaws in fixed relation.

In testimony whereof I hereunto affix my signature.

HENRY J. FOSTER.