

BEST AVAILABLE COPY

No. 793,353.

PATENTED JUNE 27, 1905.

J. H. COOK.

CROSS ARM BRACE FOR TELEGRAPH POLES.

APPLICATION FILED MAR. 7, 1904.

Fig. 1,

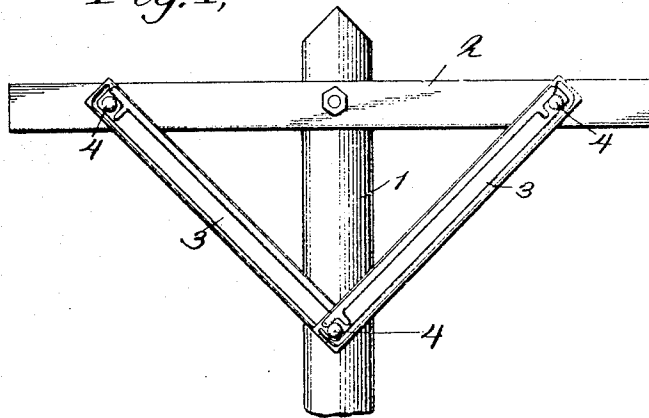

Fig. 2,

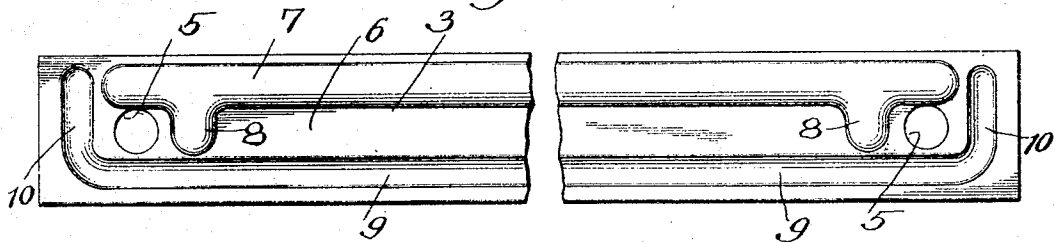

Fig. 3

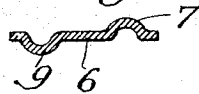

Fig. 4,

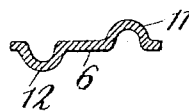
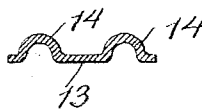

Fig. 5,



WITNESSES:

Joseph J. Collins.
Clara C. Wiedershold

INVENTOR

John H. Cook
BY

Almeida & Almeida ATTORNEYS

UNITED STATES PATENT OFFICE.

JOHN H. COOK, OF BROOKLYN, NEW YORK, ASSIGNOR TO HENRY B. NEWHALL, OF PLAINFIELD, NEW JERSEY.

CROSS-ARM BRACE FOR TELEGRAPH-POLES.

SPECIFICATION forming part of Letters Patent No. 793,353, dated June 27, 1905.

Application filed March 7, 1904. Serial No. 196,859.

To all whom it may concern:

Be it known that I, JOHN H. COOK, a citizen of the United States, and a resident of the borough of Brooklyn, New York city, county of Kings, and State of New York, have invented certain new and useful Improvements in Cross-Arm Braces for Telegraph-Poles, of which the following is a specification, reference being had to the accompanying drawings, which form a part of the same.

This invention relates to braces formed of metal, and relates especially to elongated sheet-metal braces to be secured to telegraph-poles to support the cross-arms of the same.

In the accompanying drawings, in which the same reference-numerals refer to similar parts in the several figures, Figure 1 is an elevation showing an embodiment of this invention applied to a telegraph-pole. Fig. 2 is an enlarged view showing one of the braces. Fig. 3 is a transverse section of the same, taken near one end of the brace. Fig. 4 is a similar section taken adjacent the center of the brace. Fig. 5 is a transverse sectional view of a modification.

In the embodiment of this invention shown in the drawings two of the braces 3 are indicated as secured at their lower ends to the telegraph-pole 1 by the bolt or similar securing device 4 and are secured at their upper ends to the cross-arm 2 by similar means. These braces are preferably formed of sheet metal and are subjected to a suitable forging operation, which increases the rigidity of the metal and which also forms suitable ribs or corrugations in the braces to give them additional strength and stiffness.

As indicated in Fig. 2, the brace 3 is formed with the bolt-holes 5 at either end of same and is formed with the lateral rib 9 stamped up from the body of the brace adjacent one edge of same, this rib being joined by a suitable curve with the transverse end rib 10, located beyond the bolt-holes at either end of the braces. Another lateral rib 7 is also indicated, being preferably stamped up from the opposite face of the brace and connected with the intermediate transverse ribs 8, preferably located between the bolt-holes. These

lateral ribs 7 and 9 are preferably formed of varying height, these ribs being given the greatest height at the central portion of the braces, as indicated in Fig. 4, while they do not project so far from the body of the braces at the ends of same, as indicated in Fig. 3. 55

It is not of course necessary that the ribs be stamped up from opposite faces of the braces in all cases. Fig. 5 indicates a construction in which the two lateral ribs 14 project from the same face of the brace 13. This ribbed construction allows, of course, a much lighter brace to be used without diminishing its strength, and, furthermore, the transverse ribs materially stiffen the ends of the braces and prevent deformation of the same. When the securing-bolts are inserted, these transverse ribs, which substantially inclose the bolts, operate in an obvious manner to prevent the crushing of the ends of the braces and the flattening out of the same. 70

Many modifications in the form, size, proportion, and number of parts may be made in this device by those familiar with the art. Furthermore, parts of this device may be used without employing all of the same, and parts may be used in connection with other devices without departing from the spirit of this invention or losing the advantages of the same. I do not, therefore, desire to be limited to the disclosure which has been made in this case; but what I claim as new, and what I desire to secure by Letters Patent, is set forth in the appended claims. 80

I claim—

1. In cross-arm braces, an elongated sheet-metal brace having bolt-holes adjacent the ends of same, said brace having a lateral rib adjacent one edge of the same and connected with transverse ribs extending outside of said bolt-holes, and having a lateral rib stamped up from the opposite face adjacent the opposite edge and connected with intermediate transverse ribs inside of said bolt-holes, said lateral ribs having a varying height throughout the length of the brace and having their greatest height adjacent the middle of the same. 85 90 95

2. In cross-arm braces, an elongated sheet-

metal brace having bolt-holes adjacent the
ends of the same, said brace having a lateral rib
adjacent one edge of the same and connected
with transverse ribs adjacent the bolt-holes at
5 the ends of said brace and having a lateral rib
adjacent the opposite edge and projecting
from the opposite face of said brace, said lat-
eral ribs having a varying height throughout
the length of the brace and having their great-
10 est height adjacent the middle of the same.

3. In cross-arm braces an elongated sheet-
metal brace having bolt-holes adjacent the

ends of the same, said brace having lateral
ribs adjacent the edges of the same and con-
nected with transverse ribs adjacent the holes
at the ends of said brace, said lateral ribs hav-
ing a varying height throughout the length of
the brace and having their greatest height ad-
jacent the middle of the same.

JOHN H. COOK.

Witnesses:

JESSIE B. KAY,
JAMES U. CATLOW.