

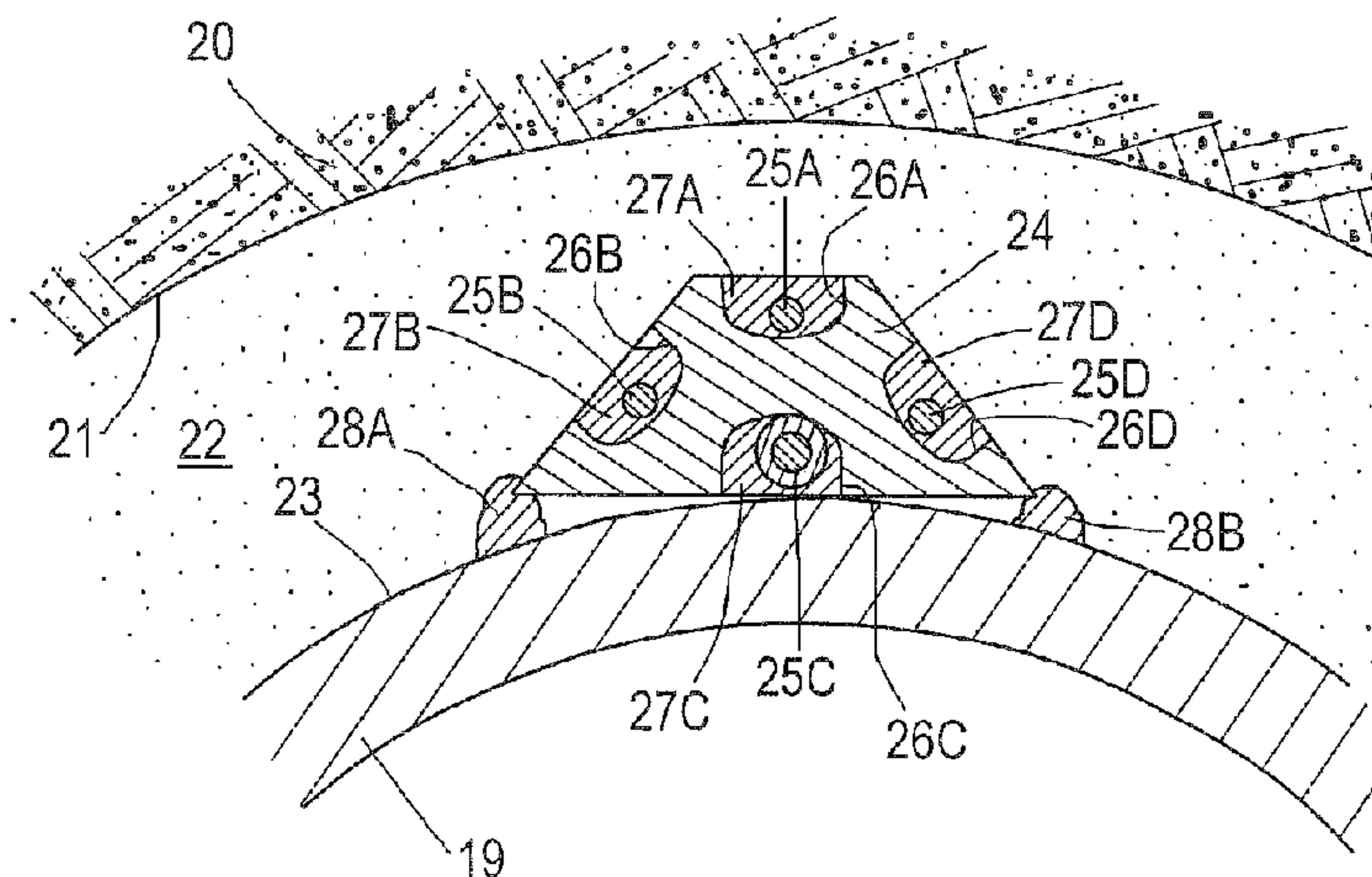

(86) Date de dépôt PCT/PCT Filing Date: 2009/12/23
 (87) Date publication PCT/PCT Publication Date: 2010/07/08
 (45) Date de délivrance/Issue Date: 2018/01/30
 (85) Entrée phase nationale/National Entry: 2011/06/28
 (86) N° demande PCT/PCT Application No.: EP 2009/067866
 (87) N° publication PCT/PCT Publication No.: 2010/076281
 (30) Priorité/Priority: 2008/12/31 (US61/141,738)

(51) Cl.Int./Int.Cl. *E21B 41/00* (2006.01),
E21B 40/00 (2006.01), *E21B 43/10* (2006.01)
 (72) Inventeur/Inventor:
JAASKELAINEN, KARI-MIKKO, US
 (73) Propriétaire/Owner:
SHELL INTERNATIONALE RESEARCH
MAATSCHAPPIJ B.V., NL
 (74) Agent: SMART & BIGGAR

(54) Titre : PROCÉDE DE SURVEILLANCE DE DEFORMATION D'EQUIPEMENT DE Puits
 (54) Title: METHOD FOR MONITORING DEFORMATION OF WELL EQUIPMENT



(57) **Abrégé/Abstract:**

A method of monitoring deformation and other characteristics of a casing (9), sandscreen, electrical heater and/or other tubular or cylindrical well equipment in a well traversing an underground formation (20), comprises: - providing a carrier rod (14) having at least one recess (16) extending along at least part of the length of the rod, in which recess an optical fiber assembly (15) for monitoring strain, temperature and/or other physical parameters is arranged, which optical fiber assembly is along at least part of its length bonded within the recess; - lowering the carrier rod and well equipment simultaneously into the well such that the carrier rod is arranged in an annular space (12) between the outer surface of the well equipment and the inner surface of the wellbore; - securing the carrier rod at a plurality of locations distributed along its length to the well equipment; - connecting the optical fiber assembly (15) to an optical signal transmission and reception assembly for monitoring deformation, strain, temperature and/or other physical parameters of the well equipment.

(12) INTERNATIONAL APPLICATION PUBLISHED UNDER THE PATENT COOPERATION TREATY (PCT)

(19) World Intellectual Property Organization
International Bureau(43) International Publication Date
8 July 2010 (08.07.2010)(10) International Publication Number
WO 2010/076281 A3

(51) International Patent Classification:

E21B 17/02 (2006.01) *E21B 43/10* (2006.01)

(21) International Application Number:

PCT/EP2009/067866

(22) International Filing Date:

23 December 2009 (23.12.2009)

(25) Filing Language:

English

(26) Publication Language:

English

(30) Priority Data:

61/141,738 31 December 2008 (31.12.2008) US

(71) Applicant (for all designated States except US): SHELL
INTERNATIONALE RESEARCH MAATSCHAPPIJ
B.V. [NL/NL]; Carel van Bylandtlaan 30, NL-2596 HR
The Hague (NL).

(72) Inventor; and

(75) Inventor/Applicant (for US only): JÄÄSKELÄINEN,
Kari-Mikko [SE/US]; 4011 Bell Hollow Lane, Katy,
Texas 77494 (US).(81) Designated States (unless otherwise indicated, for every
kind of national protection available): AE, AG, AL, AM,
AO, AT, AU, AZ, BA, BB, BG, BH, BR, BW, BY, BZ,
CA, CH, CL, CN, CO, CR, CU, CZ, DE, DK, DM, DO,
DZ, EC, EE, EG, ES, FI, GB, GD, GE, GH, GM, GT,
HN, HR, HU, ID, IL, IN, IS, JP, KE, KG, KM, KN, KP,KR, KZ, LA, LC, LK, LR, LS, LT, LU, LY, MA, MD,
ME, MG, MK, MN, MW, MX, MY, MZ, NA, NG, NI,
NO, NZ, OM, PE, PG, PH, PL, PT, RO, RS, RU, SC, SD,
SE, SG, SK, SL, SM, ST, SV, SY, TJ, TM, TN, TR, TT,
TZ, UA, UG, US, UZ, VC, VN, ZA, ZM, ZW.(84) Designated States (unless otherwise indicated, for every
kind of regional protection available): ARIPO (BW, GH,
GM, KE, LS, MW, MZ, NA, SD, SL, SZ, TZ, UG, ZM,
ZW), Eurasian (AM, AZ, BY, KG, KZ, MD, RU, TJ,
TM), European (AT, BE, BG, CH, CY, CZ, DE, DK, EE,
ES, FI, FR, GB, GR, HR, HU, IE, IS, IT, LT, LU, LV,
MC, MK, MT, NL, NO, PL, PT, RO, SE, SI, SK, SM,
TR), OAPI (BF, BJ, CF, CG, CI, CM, GA, GN, GQ, GW,
ML, MR, NE, SN, TD, TG).

Declarations under Rule 4.17:

— as to applicant's entitlement to apply for and be granted
a patent (Rule 4.17(ii))

Published:

— with international search report (Art. 21(3))
— before the expiration of the time limit for amending the
claims and to be republished in the event of receipt of
amendments (Rule 48.2(h))

(88) Date of publication of the international search report:

7 October 2010

(54) Title: METHOD FOR MONITORING DEFORMATION OF WELL EQUIPMENT

Fig.4

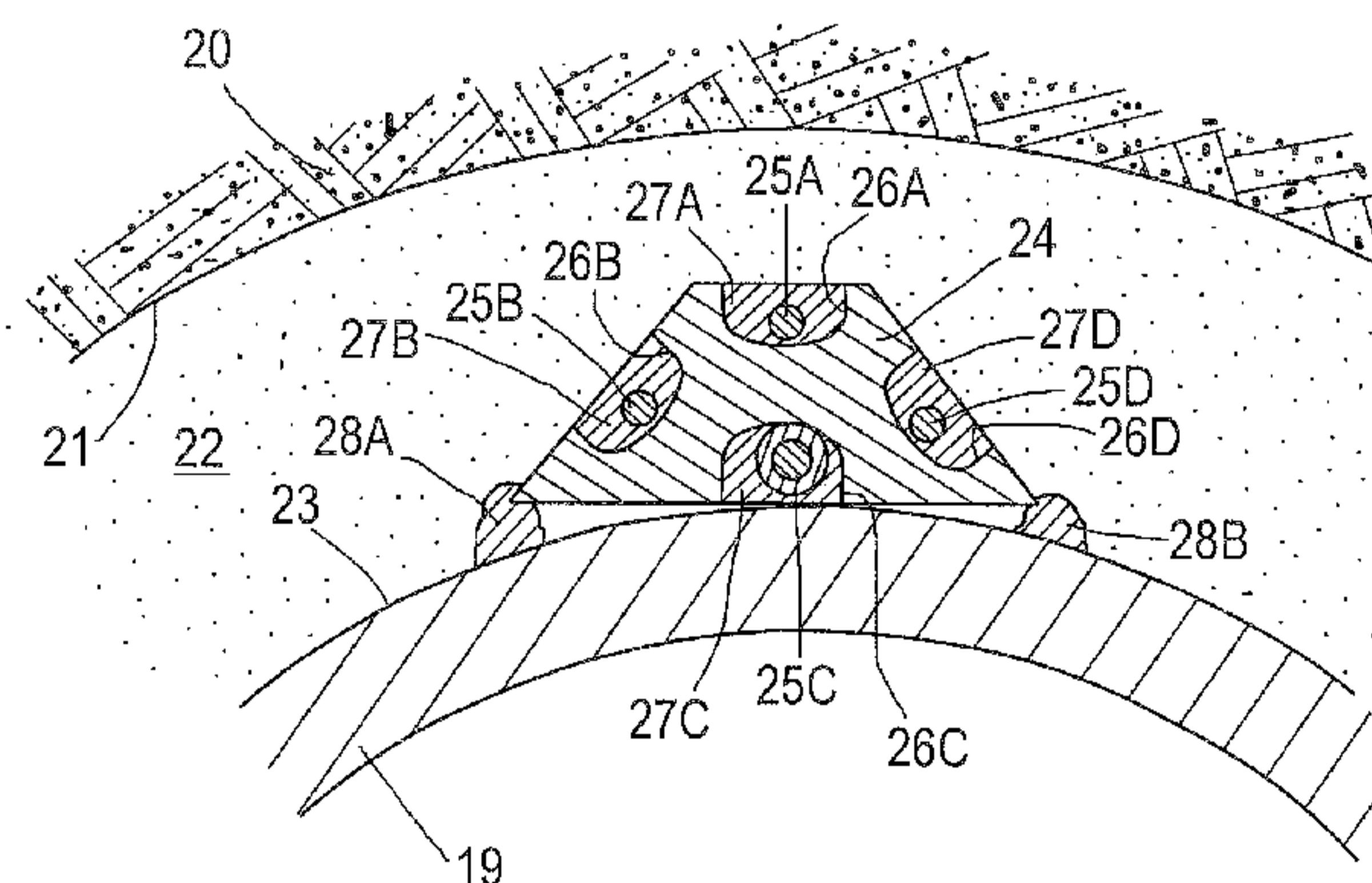

(57) Abstract: A method of monitoring deformation and other characteristics of a casing (9), sandscreen, electrical heater and/or other tubular or cylindrical well equipment in a well traversing an underground formation (20), comprises: - providing a carrier rod (14) having at least one recess (16) extending along at least part of the length of the rod, in which recess a optical fiber assembly (15) for monitoring strain, temperature and/or other physical parameters is arranged, which optical fiber assembly is along at least part of its length bonded within the recess; - lowering the carrier rod and well equipment simultaneously into the well such that the carrier rod is arranged in an annular space (12) between the outer surface of the well equipment and the inner surface of the wellbore; - securing the carrier rod at a plurality of locations distributed along its length to the well equipment; - connecting the optical fiber assembly (15) to an optical signal transmission and reception assembly for monitoring deformation, strain, temperature and/or other physical parameters of the well equipment.

WO 2010/076281 A3

METHOD FOR MONITORING DEFORMATION OF WELL EQUIPMENT
BACKGROUND OF THE INVENTION

The invention relates to a method for monitoring deformation of well equipment.

The current approach to monitor deformation of a well casing or other well equipment is to attach or glue fiber optical or other sensing cables directly to the well casing or other well equipment. Such installation of the sensing cable is cumbersome and time consuming with a significant risk of breaking the cable during attachment or during deployment in the well.

It is an object of the present invention to provide a method for monitoring deformation of a casing or other well equipment using a optical fiber assembly which can be attached quickly to the well casing and such that the optical fiber assembly is adequately protected against breaking during attachment or during deployment in the well.

SUMMARY OF THE INVENTION

In accordance with the invention there is provided a method of monitoring deformation, strain, temperature and/or other physical characteristics of a casing, sandscreen, electrical heater and/or other tubular or cylindrical well equipment in a well traversing an underground formation, the method comprising:

- providing a carrier rod having at least one recess extending along at least part of the length of the rod, in which recess a optical fiber assembly for monitoring strain, temperature and/or other physical parameters is arranged, which optical fiber assembly is along at least part of its length bonded within the recess;

- lowering the carrier rod and well equipment simultaneously into the well such that the carrier rod is arranged in an annular space between the outer surface of the well equipment and the inner surface of the wellbore;

5 - securing the carrier rod at a plurality of locations distributed along its length to the well equipment;

- connecting the optical fiber assembly to an optical signal transmission and reception assembly which is configured to transmit optical signals through the

10 optical fiber assembly and to monitor deformation, strain, temperature and/or other physical parameters of the well equipment on the basis of any relationship between these parameters and reflection and/or modification of optical signals at different locations

15 along the length of the optical fiber assembly.

It is preferred that the carrier rod comprises a material having similar thermal expansion, and mechanical properties as the casing, sandscreen, electrical heater and/or other well equipment.

20 The carrier rod may be arranged on a coil and bent into a substantially straight position before it is lowered into the well and may be attached along selected intervals of its length by straps, welding, brazing and/or a bonding agent to the casing, sandscreen and/or

25 other well equipment before it is lowered into the well.

Alternatively, the carrier rod may be secured to a tubular piece of well equipment by filling at least part of an annular space between the outer surface of the well equipment and the inner surface of the wellbore with a

30 cement or other hardening composition and/or by expanding the tubular piece of well equipment such that at least part of an outer surface thereof is pressed against the inner surface of the wellbore.

81656482

- 3 -

Optionally, a plurality of carrier rods with optical fiber assemblies embedded in longitudinal recess are arranged at regular circumferential intervals around the outer surface of a tubular or cylindrical piece of well equipment.

5 The method according to the invention may be used to monitor deformation of tubular or cylindrical well equipment during crude hydrocarbon fluid production operations and/or during steam injection into or electrical heating of a hydrocarbon containing formation, and wherein the monitored
10 deformation of the well equipment is taken into account to adapt, modify and/or control the hydrocarbon fluid production, steam injection and/or electrical heating operations.

 According to one aspect of the present invention, there is provided a method of monitoring deformation, strain,
15 temperature or other physical characteristics of a casing, sandscreen, electrical heater or other tubular or cylindrical well equipment in a well traversing an underground formation, the method comprising: providing a carrier rod having at least one recess extending along at least part of the length of the
20 rod, the recess having an outer width, in which recess an optical fiber assembly for monitoring strain, temperature or other physical parameters is arranged, which optical fiber assembly is along at least part of the optical fiber assembly's length bonded within the recess with a filler, the filler
25 surrounding the optical fiber assembly, and the carrier rod is surrounded by two layers of protective coatings, of which an inner layer is in contact with the filler across the full recess outer width; lowering the carrier rod and well equipment simultaneously into the well such that the carrier rod is

81656482

- 3a -

arranged in an annular space between an outer surface of the well equipment and an inner surface of the wellbore; securing the carrier rod at a plurality of locations distributed along the length of the carrier rod to the well equipment; and

5 connecting the optical fiber assembly to an optical signal transmission and reception assembly which is configured to transmit optical signals through the optical fiber assembly and to monitor deformation, strain, temperature or other physical parameters of the well equipment on the basis of any

10 relationship between these parameters and reflection or modification of the optical signals at different locations along the length of the optical fiber assembly.

According to another aspect of the present invention, there is provided a carrier rod for lowering an optical fiber

15 assembly into a well, said carrier rod having at least one recess extending along at least part of the length of the rod, the recess having an outer width, in which recess an optical fiber assembly for monitoring strain, temperature or other physical parameters is arranged, which optical fiber assembly

20 is along at least part of the optical fiber assembly's length bonded within the recess with a filler, whereby the filler surrounding the optical fiber assembly and the carrier rod is surrounded by two layers of protective coatings of which an inner layer is in contact with the filler across the full

25 recess outer width.

According to another aspect of the present invention, there is provided a system for monitoring deformation, strain, temperature or other physical characteristics of a casing, sandscreen, electrical heater or other tubular or cylindrical

81656482

- 3b -

well equipment in a well traversing an underground formation, comprising: a carrier rod for lowering an optical fiber assembly into the well, said carrier rod having at least one recess extending along at least part of the length of the rod, the recess having an outer width, in which recess an optical fiber assembly for monitoring strain, temperature or other physical parameters is arranged, which optical fiber assembly is along at least part of the optical fiber assembly's length bonded within the recess with a filler, whereby the filler surrounding the optical fiber assembly and the carrier rod is surrounded by two layers of protective coatings of which an inner layer is in contact with the filler across the full recess outer width; and an optical signal transmission and reception assembly connected to the optical fiber assembly.

These and other features, embodiments and advantages of the method and according to the invention are described in the accompanying claims, abstract and the following detailed description of preferred embodiments disclosed in the accompanying drawings in which reference numerals are used which refer to corresponding reference numerals that are shown in the drawings.

BRIEF DESCRIPTION OF THE DRAWINGS

Fig.1 shows a longitudinal sectional view of bend well casing within a curved wellbore;

Fig.2 shows, at a larger scale than in Fig.1 a cross-sectional view of the bend well casing of Fig.1 around which four rods with recesses in which strain monitoring optical fiber assemblies are arranged;

81656482

- 3c -

Fig.3 shows a cross sectional view of a section of a well casing to which a rod with a recess, in which a strain monitoring assembly is arranged, is secured by spot welding;

63293-4313

- 4 -

Fig.4 shows a cross sectional view of a section of a well casing to which a rod with a plurality of recesses, in which a strain monitoring assemblies are arranged, is secured by spot welding;

5 Fig.5 shows an alternative embodiment of the rod, wherein the rod has a square cross-sectional shape;

Fig.6 shows another alternative embodiment of the rod, wherein the rod has a cylindrical cross-sectional shape; and

10 Fig.7 shows yet another alternative embodiment of the rod, wherein the rod has a cylindrical cross-sectional shape;

DETAILED DESCRIPTION OF THE DEPICTED EMBODIMENTS

15 Fig.1 shows a curved wellbore 1 in which a bend casing 3 is arranged. The casing 3 is secured within the wellbore 1 by cement 2, which fills the annular space between the outer surface of the casing 3 and the inner surface of the wellbore 1.

20 In order to monitor stress, deformation, temperature and other features a series of four rods 4A-4D are embedded in the cement 2 around the casing 3. As illustrated in Fig.2 each rod has a recess in which an optical strain monitoring fiber 5A-5D is embedded. The rods 4A-4D are preferably made of the same metal as the
25 casing 3.

30 Fig.3 shows in more detail a cross sectional view of an alternative embodiment of a rod 14, wherein the rod has a rectangular shape and is arranged in a cement body 12 between the inner surface 11 of a wellbore in an underground earth formation 10 and the outer surface 13 of a casing 9. The rod 14 has a recess 16 in which an optical strain monitoring fiber 15 is embedded within a protective filler 17. The rod 14 is secured at selected

intervals along its length to the outer surface 13 of the casing 9 by spot welds 18A-B.

Fig.4 shows a cross sectional view of an another alternative embodiment of a rod 24, wherein the rod has a trapezoidal shape and is arranged in a cement body 22 between the inner surface 21 of a wellbore in an underground earth formation 20 and the outer surface 23 of a casing 19. The rod 24 has at each of its four sides a recess 26A-D in which an optical strain monitoring fiber 25A-D is embedded within a protective filler 27A-D. The rod 24 is secured at selected intervals along its length to the outer surface 23 of the casing 19 by spot welds 28A-B. The optical fiber 25C is configured to measure temperature.

Fig.5 shows a cross sectional view of yet another embodiment of a rod 34, wherein the rod has a square cross-sectional shape and has at each of its four sides a recess 36A-D in which an optical strain monitoring fiber 35A-D is embedded with a protective filler 37A-D.

Fig.6 shows a cross sectional view of yet another embodiment of a rod 44, wherein the rod has a cylindrical cross-sectional shape and has at each of its four sides a recess 46A-D in which an optical strain monitoring fiber 45A-D is embedded with a protective filler 47A-D.

The rod 44 is surrounded by two concentric layers of protective coatings 48,49.

Fig.7 shows a cross sectional view of yet another embodiment of a rod 54, wherein the rod has a cylindrical cross-sectional shape and has at each of its four sides a recess 56A-D in which an optical strain monitoring fiber 55A-D is embedded with a protective filler 57A-D.

81656482

- 6 -

CLAIMS:

1. A method of monitoring deformation, strain, temperature or other physical characteristics of a casing, sandscreen, electrical heater or other tubular or cylindrical well equipment in a well traversing an underground formation, the method comprising:

providing a carrier rod having at least one recess extending along at least part of the length of the rod, the recess having an outer width, in which recess an optical fiber assembly for monitoring strain, temperature or other physical parameters is arranged, which optical fiber assembly is along at least part of the optical fiber assembly's length bonded within the recess with a filler, the filler surrounding the optical fiber assembly, and the carrier rod is surrounded by two layers of protective coatings, of which an inner layer is in contact with the filler across the full recess outer width;

lowering the carrier rod and well equipment simultaneously into the well such that the carrier rod is arranged in an annular space between an outer surface of the well equipment and an inner surface of the wellbore;

securing the carrier rod at a plurality of locations distributed along the length of the carrier rod to the well equipment; and

connecting the optical fiber assembly to an optical signal transmission and reception assembly which is configured to transmit optical signals through the optical fiber assembly and to monitor deformation, strain, temperature or other physical parameters of the well equipment on the basis of any

81656482

- 7 -

relationship between these parameters and reflection or modification of the optical signals at different locations along the length of the optical fiber assembly.

2. The method of claim 1, wherein the carrier rod
5 comprises a material having similar thermal expansion, and mechanical properties as the casing, sandscreen, electrical heater or other well equipment.

3. The method of claim 1, wherein the carrier rod is
10 made of the same material as the casing, sandscreen or other well equipment.

4. The method of claim 1, wherein the carrier rod is arranged on a coil and bent into a substantially straight position before the carrier rod is lowered into the well.

5. The method of claim 1, wherein the carrier rod is
15 attached along selected intervals of the carrier rod's length by straps to the casing, sandscreen or other well equipment before the carrier rod is lowered into the well.

6. The method of claim 5, wherein the carrier rod is secured to a tubular piece of well equipment by filling at
20 least part of an annular space between the outer surface of the well equipment and the inner surface of the wellbore with a cement or other hardening composition.

7. The method of claim 5, wherein the carrier rod is secured to a tubular piece of well equipment by expanding the
25 tubular piece of well equipment such that at least part of an outer surface thereof is pressed against the inner surface of the wellbore.

81656482

- 8 -

8. The method of claim 1, wherein the carrier rod is secured to a tubular piece of well equipment by filling at least part of an annular space between the outer surface of the well equipment and the inner surface of the wellbore with a
5 cement or other hardening composition.

9. The method of claim 1, wherein the carrier rod is secured to a tubular piece of well equipment by expanding the tubular piece of well equipment such that at least part of an outer surface thereof is pressed against the inner surface of
10 the wellbore.

10. The method of claim 1, wherein the carrier rod is disposed longitudinally aligned with and parallel to the casing, sandscreen, electrical heater or other tubular or cylindrical well equipment.

15 11. The method of claim 1, wherein a plurality of carrier rods with optical fiber assemblies are provided.

12. The method of claim 11, wherein the recess is longitudinal to the carrier rod and each optical fiber assembly is embedded in one longitudinal recess.

20 13. The method of claim 12, wherein the carrier rods of the plurality of carrier rods are arranged at regular circumferential intervals around the outer surface of a tubular or cylindrical piece of well equipment.

25 14. The method of claim 11, wherein the carrier rods of the plurality of carrier rods are arranged at regular circumferential intervals around the outer surface of a tubular or cylindrical piece of well equipment.

81656482

- 9 -

15. The method of claim 1, wherein the recess is longitudinal to the carrier rod.

16. The method of claim 15, wherein a plurality of carrier rods with optical fiber assemblies are provided, each
5 embedded in one longitudinal recess.

17. The method of claim 16, wherein the carrier rods of the plurality of carrier rods are arranged at regular circumferential intervals around the outer surface of a tubular or cylindrical piece of well equipment.

10 18. The method of claim 1, wherein the method is used to monitor deformation of tubular or cylindrical well equipment during crude hydrocarbon fluid production operations, and wherein the monitored deformation of the well equipment is taken into account to adapt, modify or control the crude
15 hydrocarbon fluid production operations.

19. The method of claim 1, wherein the method is used to monitor deformation of tubular or cylindrical well equipment during steam injection into a hydrocarbon containing formation, and wherein the monitored deformation of the well equipment is
20 taken into account to adapt, modify or control the steam injection.

20. The method of claim 1, wherein the method is used to monitor deformation of tubular or cylindrical well equipment during electrical heating of a hydrocarbon containing
25 formation, and wherein the monitored deformation of the well equipment is taken into account to adapt, modify or control the electrical heating.

81656482

- 10 -

21. A carrier rod for lowering an optical fiber assembly into a well, said carrier rod having at least one recess extending along at least part of the length of the rod, the recess having an outer width, in which recess an optical fiber assembly for monitoring strain, temperature or other physical parameters is arranged, which optical fiber assembly is along at least part of the optical fiber assembly's length bonded within the recess with a filler, whereby the filler surrounding the optical fiber assembly and the carrier rod is surrounded by two layers of protective coatings of which an inner layer is in contact with the filler across the full recess outer width.

22. The carrier rod of claim 21 secured at a plurality of locations distributed along the length of the carrier rod to a casing, a sandscreen, an electrical heater or other tubular or cylindrical well equipment.

23. The carrier rod of claim 22, wherein the carrier rod comprises a material having similar thermal expansion, and mechanical properties as the casing, sandscreen, electrical heater or other well equipment.

24. The carrier rod of claim 22, wherein the carrier rod is made of the same material as the casing, sandscreen or other well equipment.

25. The carrier rod of claim 22, wherein the carrier rod is secured to a tubular piece of well equipment by filling at least part of an annular space between an outer surface of the well equipment and an inner surface of a wellbore with a cement or other hardening composition.

81656482

- 11 -

26. The carrier rod of claim 22, wherein the carrier rod is secured to a tubular piece of well equipment by expanding the tubular piece of well equipment such that at least part of an outer surface thereof is pressed against an inner surface of
5 a wellbore.

27. The carrier rod of claim 22, wherein the carrier rod is disposed longitudinally aligned with and parallel to the casing, sandscreen, electrical heater or other tubular or cylindrical well equipment.

10 28. The carrier rod of claim 21 arranged on a coil.

29. The carrier rod of claim 21, wherein the recess is longitudinal to the carrier rod.

30. The carrier rod of claim 29, wherein carrier rods of a plurality of carrier rods are arranged at regular
15 circumferential intervals around an outer surface of a tubular or cylindrical piece of well equipment.

31. The carrier rod of claim 21 in use to monitor deformation of tubular or cylindrical well equipment during crude hydrocarbon fluid production operations.

20 32. The carrier rod of claim 21 in use to monitor deformation of tubular or cylindrical well equipment during steam injection into a hydrocarbon containing formation.

33. The carrier rod of claim 21 in use to monitor deformation of tubular or cylindrical well equipment during
25 electrical heating of a hydrocarbon containing formation.

81656482

- 12 -

34. A system for monitoring deformation, strain, temperature or other physical characteristics of a casing, sandscreen, electrical heater or other tubular or cylindrical well equipment in a well traversing an underground formation,
5 comprising:

- a carrier rod for lowering an optical fiber assembly into the well, said carrier rod having at least one recess extending along at least part of the length of the rod, the recess having an outer width, in which recess an optical fiber assembly for
10 monitoring strain, temperature or other physical parameters is arranged, which optical fiber assembly is along at least part of the optical fiber assembly's length bonded within the recess with a filler, whereby the filler surrounding the optical fiber assembly and the carrier rod is surrounded by two layers of
15 protective coatings of which an inner layer is in contact with the filler across the full recess outer width; and
- an optical signal transmission and reception assembly connected to the optical fiber assembly.

35. The system of claim 34 wherein the carrier rod is
20 secured at a plurality of locations distributed along the length of the carrier rod to the casing, sandscreen, electrical heater or other tubular or cylindrical well equipment.

36. The system of claim 35, wherein the carrier rod comprises a material having similar thermal expansion, and
25 mechanical properties as the casing, sandscreen, electrical heater or other well equipment.

81656482

- 13 -

37. The system of claim 35, wherein the carrier rod is made of the same material as the casing, sandscreen or other well equipment.

38. The system of claim 34, wherein the carrier rod is
5 disposed longitudinally aligned with and parallel to the casing, sandscreen, electrical heater or other tubular or cylindrical well equipment.

39. The system of claim 34, wherein the recess is longitudinal to the carrier rod.

10 40. The system of claim 34 wherein the optical signal transmission and reception assembly is configured to transmit optical signals through the optical fiber assembly and to monitor deformation, strain, temperature or other physical parameters of the well equipment on the basis of any
15 relationship between these parameters and reflection or modification of the optical signals at different locations along the length of the optical fiber assembly.

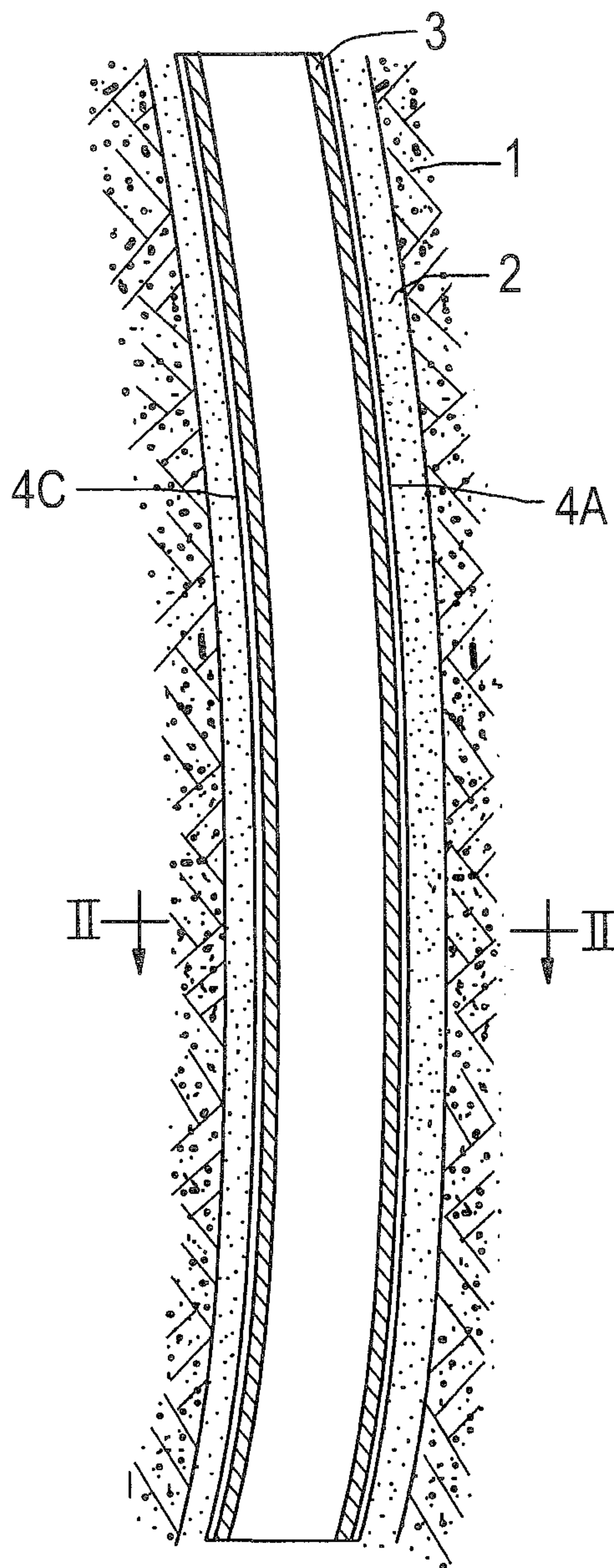

Fig. 1

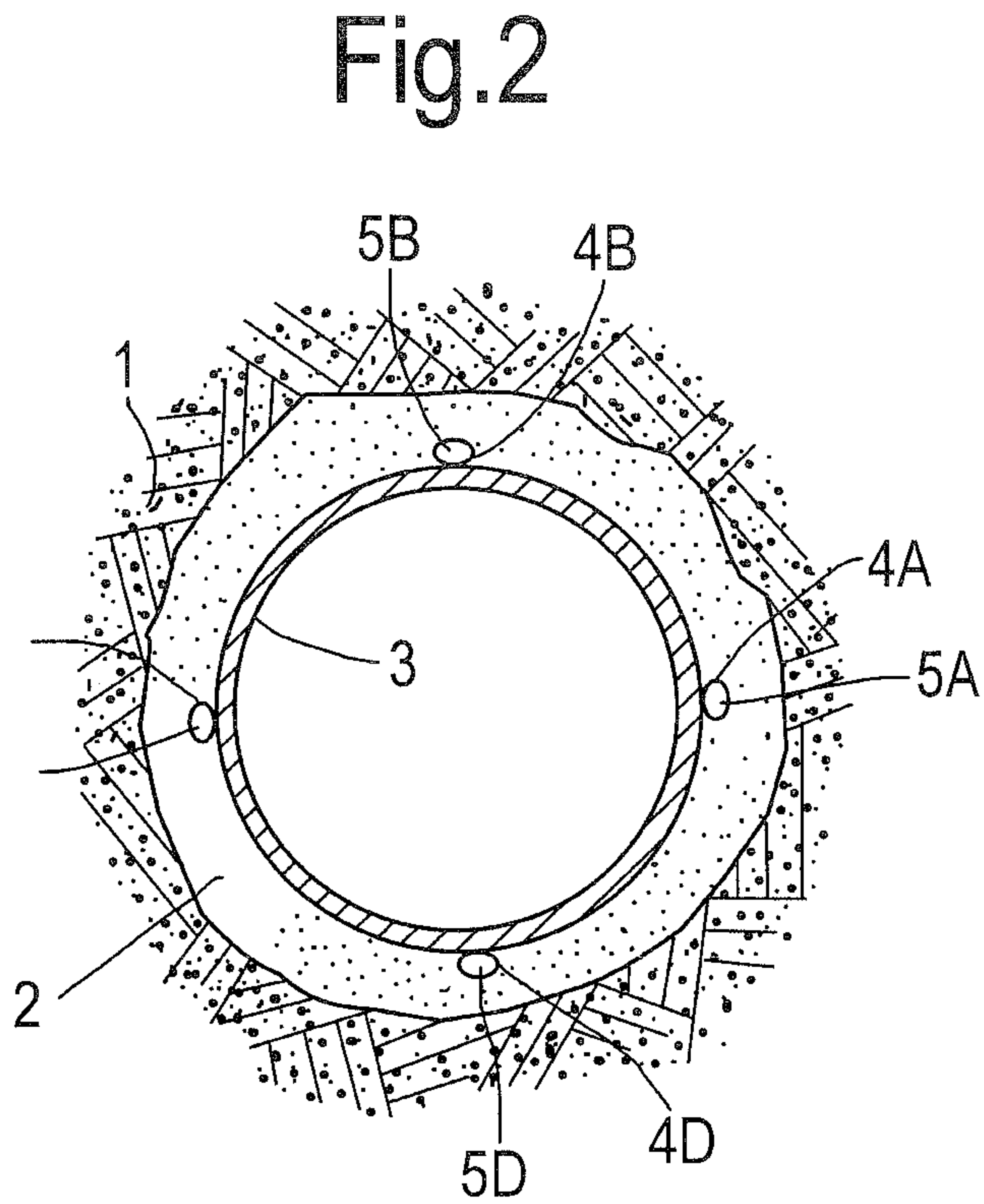

Fig. 2

Fig.3

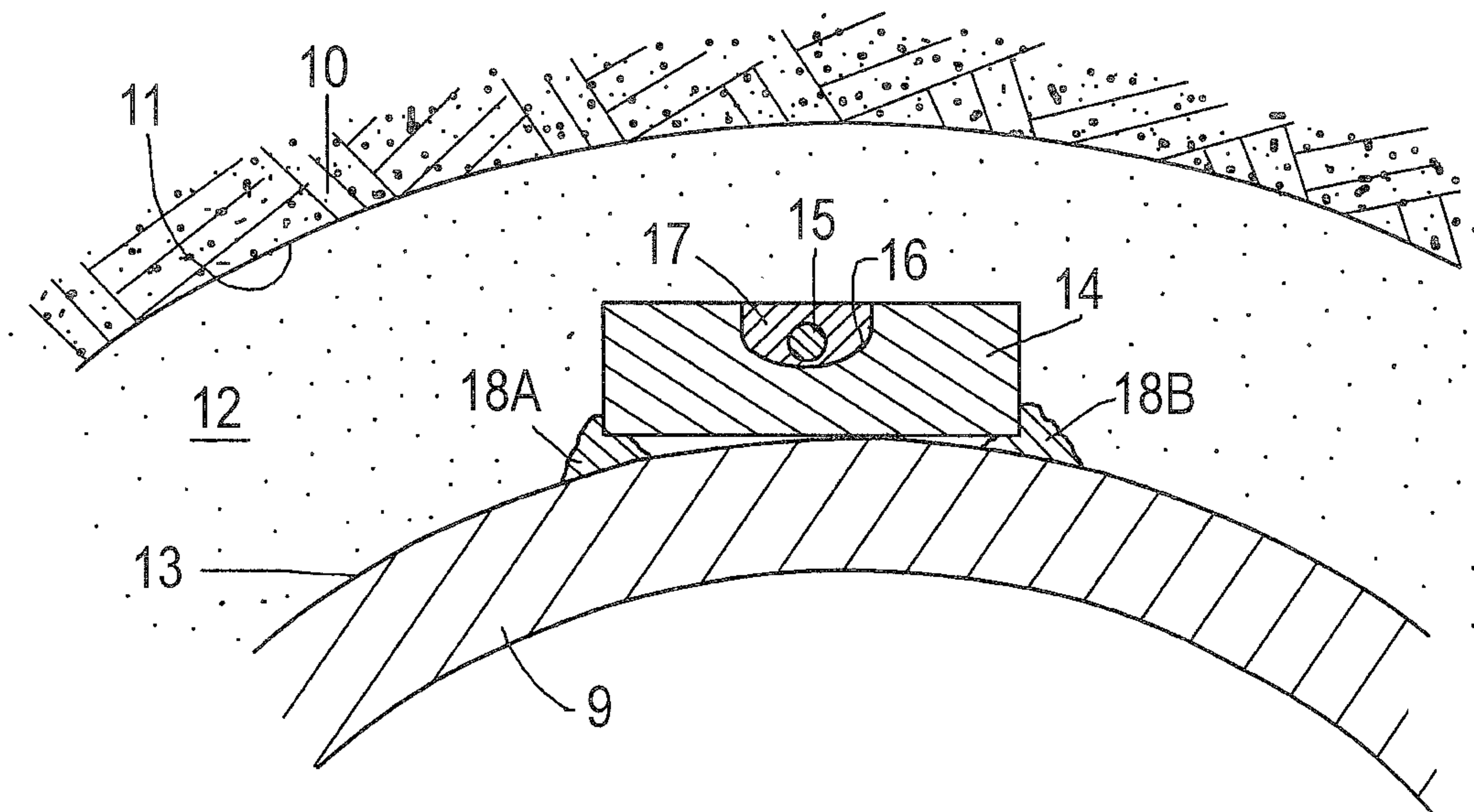

Fig.4

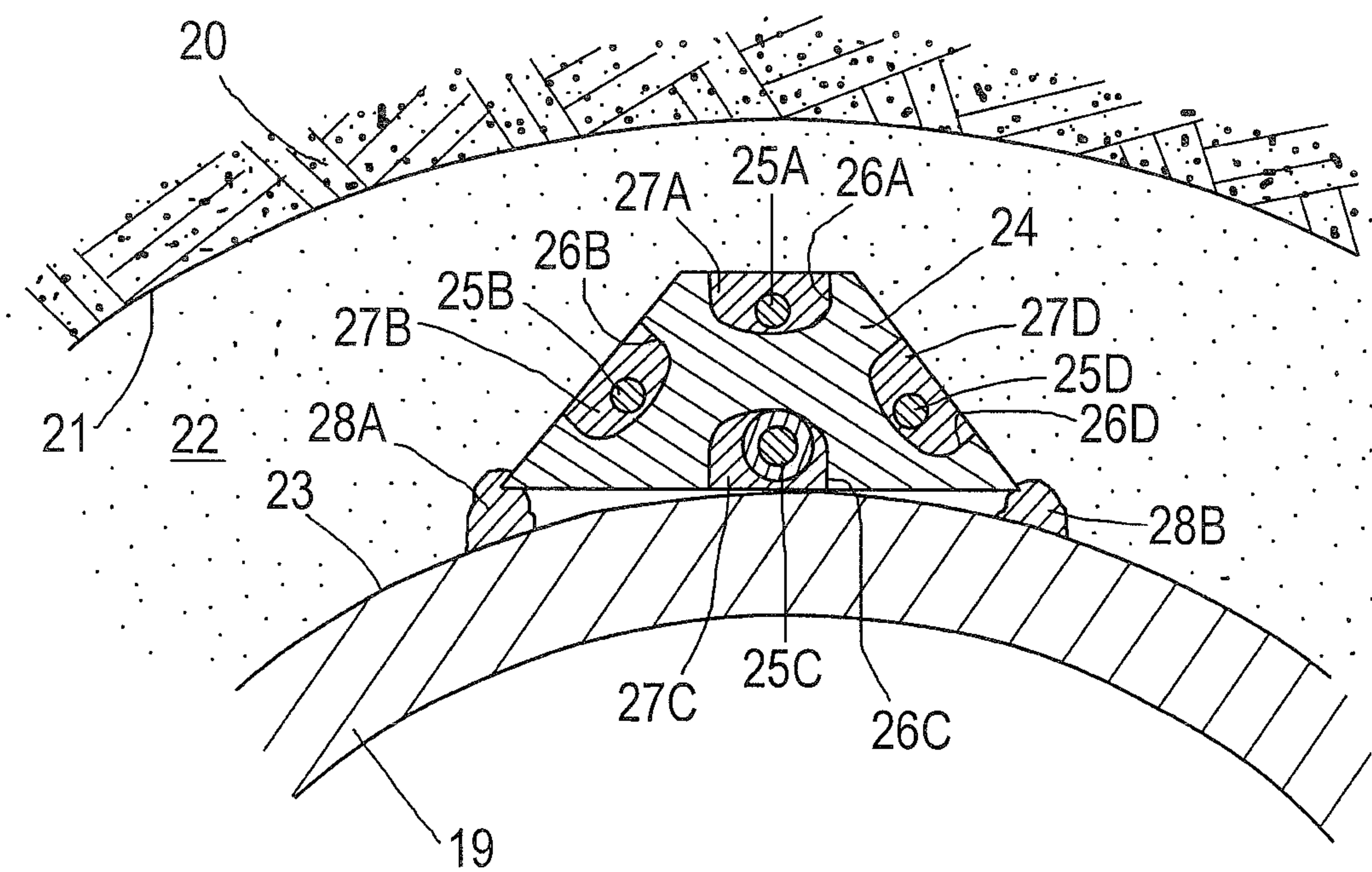

Fig.5

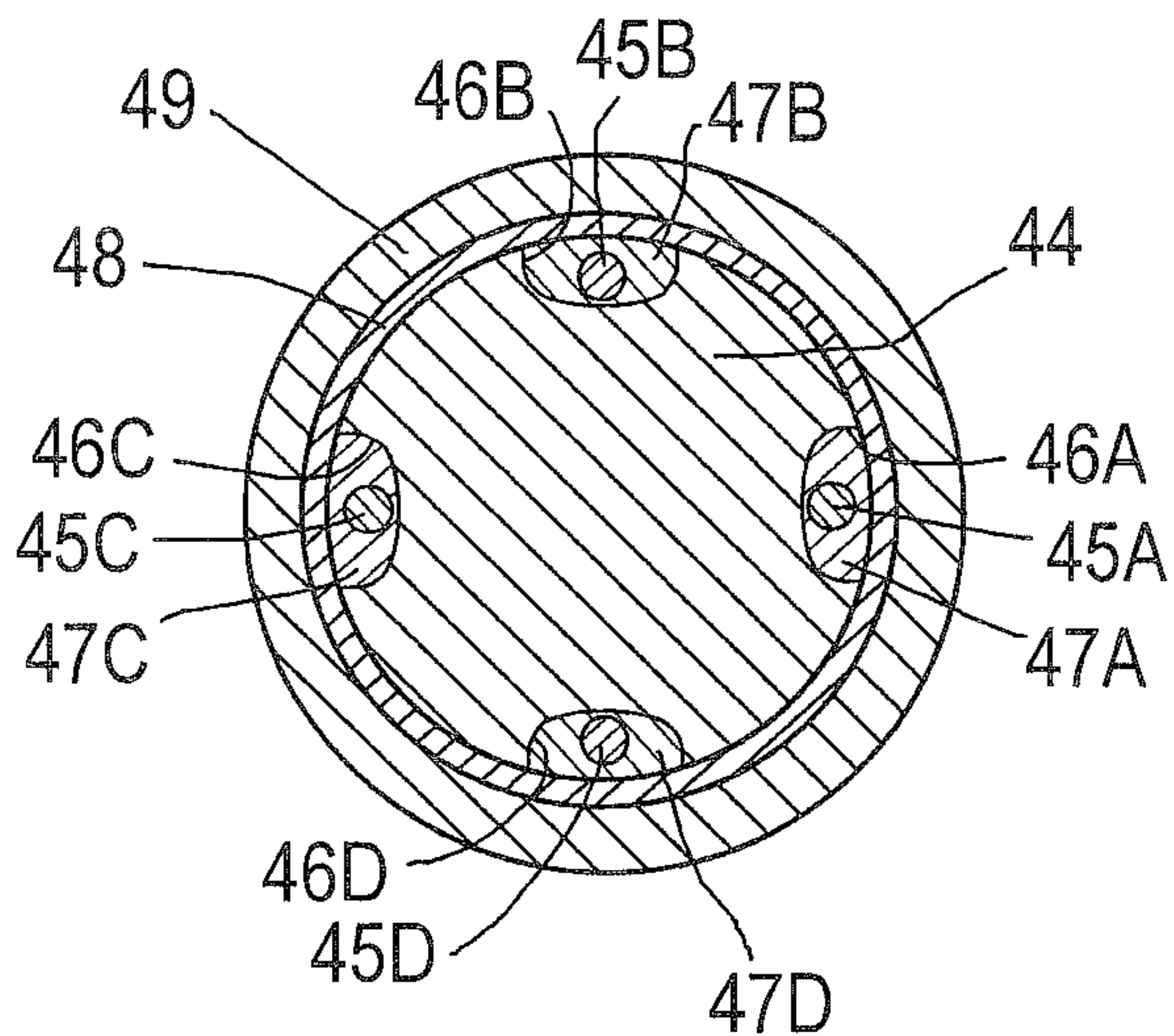
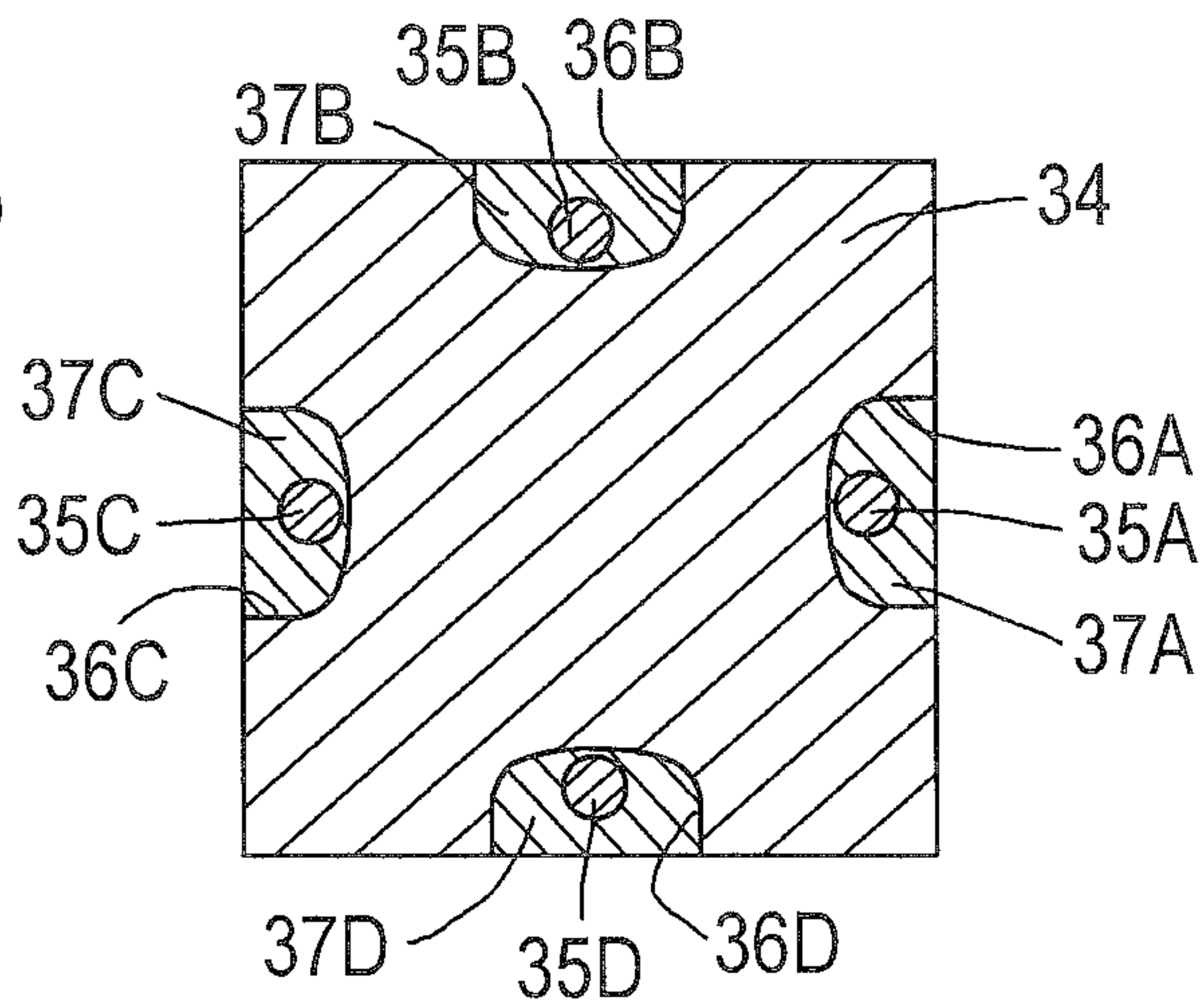

Fig.6

Fig.7

