

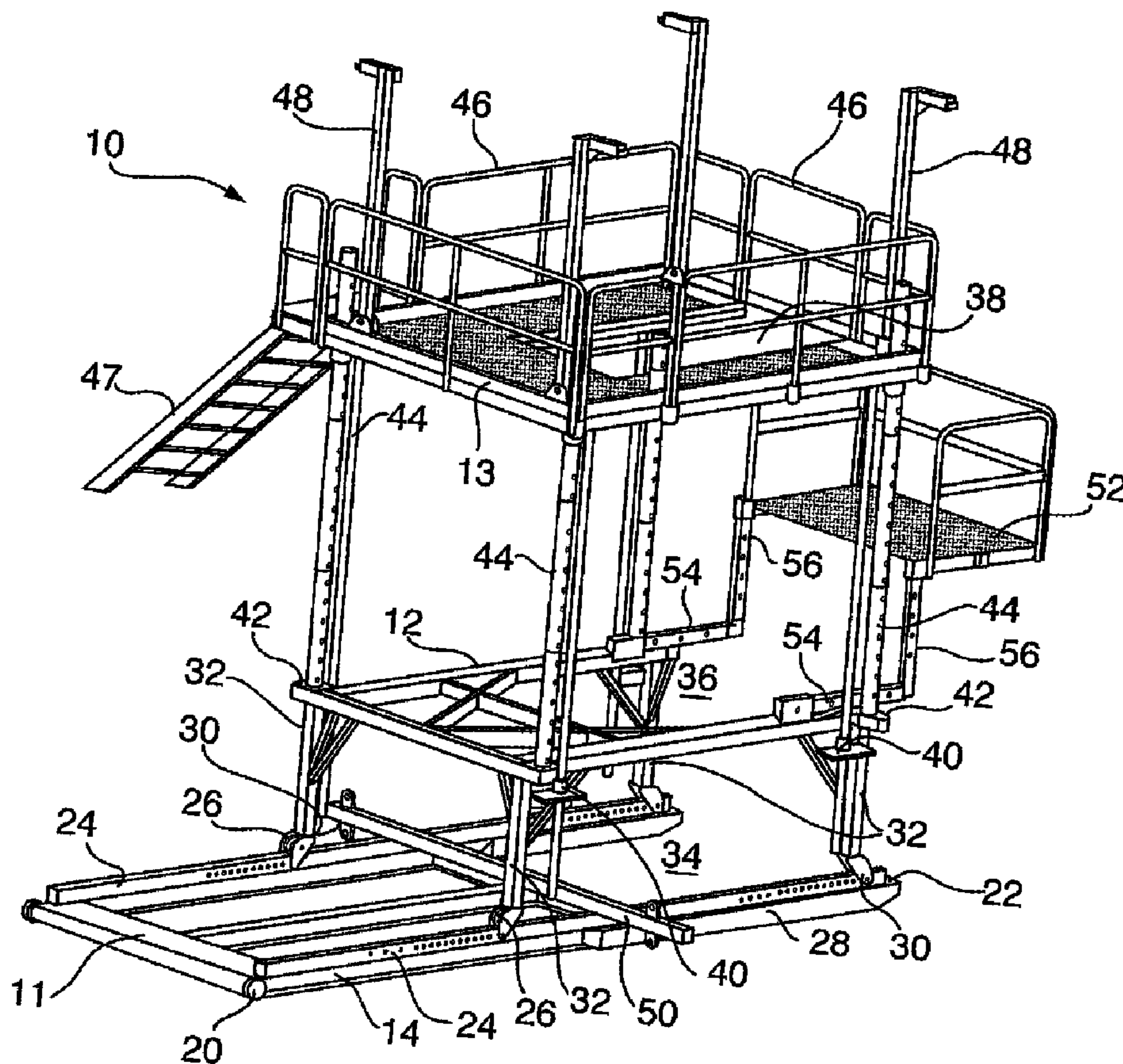

(22) Date de dépôt/Filing Date: 2008/04/22
(41) Mise à la disp. pub./Open to Public Insp.: 2009/10/22

(51) Cl.Int./Int.Cl. *E04G 1/18* (2006.01),
E04G 5/14 (2006.01), *E21B 41/00* (2006.01)
(71) Demandeur/Applicant:
SMITH, PAUL RICHARD, CA
(72) Inventeur/Inventor:
SMITH, PAUL RICHARD, CA
(74) Agent: RIDOUT & MAYBEE LLP

(54) Titre : PLATE-FORME MOBILE DE TETE DE PUIT
(54) Title: MOVABLE WELLHEAD PLATFORM



(57) Abrégé/Abstract:

A movable platform system for performing workover tasks on a wellhead includes a platform base with a base wellhead access gap at its front end. At least one track is fixed to the upper surface of the platform base and extends from the rear of the platform base to

(57) **Abrégé(suite)/Abstract(continued):**

a position near the rearward edge of the base wellhead access gap. A platform support frame with a wellhead access gap at its front end is coupled to the track and configured for movement along the length of the track. An upper platform is connected to the platform support frame and also has a platform wellhead access gap at its front end. The three wellhead access gaps at the three levels of the platform system are substantially aligned when the moveable platform support frame is disposed and locked in the working position above the wellhead. Workers on the upper platform have access to equipment surrounding the wellhead.

ABSTRACT

A movable platform system for performing workover tasks on a wellhead includes a platform base with a base wellhead access gap at its front end. At least one track is fixed to the upper surface of the platform base and extends from the rear of the platform base to a position near the rearward edge of the base wellhead access gap. A platform support frame with a wellhead access gap at its front end is coupled to the track and configured for movement along the length of the track. An upper platform is connected to the platform support frame and also has a platform wellhead access gap at its front end. The three wellhead access gaps at the three levels of the platform system are substantially aligned when the moveable platform support frame is disposed and locked in the working position above the wellhead. Workers on the upper platform have access to equipment surrounding the wellhead.

MOVABLE WELLHEAD PLATFORM

FIELD OF THE INVENTION

This invention relates generally to the field of temporary work platforms for oil and gas wellheads and more particularly to platforms designed for
5 facilitating different types of work being performed on or around wellheads in the absence of drilling rigs.

BACKGROUND OF THE INVENTION

Producing oil and natural gas wells occasionally requires major repairs or modifications, called "workovers." A workover may last anywhere from a few
10 days to several weeks to accomplish. Workover services are occasionally carried out with the same type of rig used to perform maintenance services, although the rig often is outfitted with specialized equipment including rotary drilling equipment, mud pumps, mud tanks and blowout preventers. In many cases it is convenient to perform workovers in the absence of drilling rigs. Such workover
15 examples may require the use of endless tubing units, wire line units, snubbing units and fracture stimulation units for example. In addition to workover of an existing well, various tasks need to be performed to plug a well whose useful lifetime is finished. These tasks are typically described as "completion" tasks. The completion process may involve selectively perforating the well casing at
20 the depth of discrete producing zones and installing down-hole equipment. Workover or completion tasks may take anywhere from a few days to several weeks to accomplish.

In most cases when such workover completion work is being performed on a wellhead, ordinary modular-type scaffolding is erected around the wellhead
25 so that workers can access the equipment vertically erected around the wellhead. This scaffolding is inconvenient for several reasons. It takes significant time to assemble and certify for safety, it can be unstable on frozen ground that is subject to thawing by steam heaters employed in the vicinity of the wellhead, and is not easily moved to accommodate exchange of equipment

- 2 -

at the wellhead. In addition, this type of scaffolding is accessed by ladders which represent an additional safety hazard.

U.S. Patent 6,681,894 discloses a portable wellhead platform that provides access of personnel to the wellhead during workover and snubbing operations which is coupled directly to the wellhead with a pipe flange adaptor.

U.S. Patent 6,848,539 also discloses a demountable wellhead platform that is supported above the wellhead by an armature connected to a blow-out preventer stack.

U.S. Patent Application 20070193749 discloses a mobile transport platform for a snubbing system which has substantially all of the equipment mounted thereon as required for snubbing operations. The system comprises a snubbing structure with work platforms pivotally mounted at the rear of an equipment bed of a truck.

PCT publication WO2006019880 discloses a truck mounted, self propelled unit that includes a self-erecting mast that includes a work platform supported in the horizontal position over the wellhead. The work platform is typically mounted to the rear of the truck.

Thus, prior attempts to provide a convenient work platform for workover and completion operations at oil and gas wellheads have provided platforms that are connected to equipment disposed at the wellhead itself, or integrally connected to a vehicle. There is a need for a more flexible and inexpensive workover platform that allows convenient access to the wellhead for exchange or repair of equipment disposed thereon. The present invention satisfies this need, among others.

25

SUMMARY OF THE INVENTION

The present invention provides a movable platform system for performing workover tasks on a wellhead. The system includes a platform base with a base wellhead access gap at its front end. At least one track is fixed to the upper surface of the platform base and extends from the rear of the platform base to a position near the rearward edge of the wellhead access gap. A platform support frame with a wellhead access gap at its front end is coupled to the track and

30

- 3 -

configured for movement along the length of the track. An upper platform is connected to the platform support frame and also has a platform wellhead access gap at its front end. The three wellhead access gaps at the three levels of the platform system are substantially aligned when the moveable platform support frame is disposed and locked in the working position above the wellhead, so that workers on the upper platform have access to equipment surrounding the wellhead.

When equipment repair or exchange is necessary at the wellhead, the platform support frame is unlocked from the track and can be moved rearwardly along the track to provide free space in the vicinity of the wellhead. The platform support frame can then also be locked in its rearward position along the track.

The upper platform can be vertically adjusted and the upper platform is conveniently modified to include various safety features such as removable or foldable guard rails, safety tether anchoring posts and stairs extending from the upper platform to the ground or to the platform base.

BRIEF DESCRIPTION OF THE DRAWINGS

FIG. 1 is a front perspective view of the platform system according to an embodiment of the present invention.

FIG. 2 is a top perspective view of the platform base and the platform support frame according to an embodiment of the present invention.

FIG. 3 is a side view of the platform base and the platform support frame according to an embodiment of the present invention.

FIG. 4 is a front perspective view of the platform system according to an embodiment of the present invention, with the upper platform omitted for clarity.

- 4 -

FIG. 5 is a rear perspective view of the upper platform according to one embodiment of the present invention.

DETAILED DESCRIPTION

An embodiment of the movable platform system is shown by way of example with reference to Figures 1 to 5. The platform system **10** includes as main components, a platform base **11**, a platform support frame **12** which is moveable with respect to the platform base **11** and an upper platform **13** which is connected to the platform support frame **12** and moves cooperatively therewith.

10 In the embodiment shown, a platform base **11** is constructed with elongated skid members **14** although other constructions of platform bases are possible, such as for example, a one-piece flat base. In the illustrated embodiment, transverse reinforcing members **16** connect the skid members and may be optionally fitted with reinforced flanges **18**. The rear ends of the skid
15 members may be fitted with platform base wheels **20** whose function is to facilitate rolling movement of the entire platform system **10** along the ground or along a flat surface between the platform and the ground, when the forward edge **22** of the platform base **11** is lifted and pushed.

In the embodiment shown in the figures, tracks **24** are attached to the
20 skid members **14**. The tracks are each configured to retain ridged wheels **26** in a manner similar to the way a typical train wheel engages a train track for secure movement along the track. Other arrangements are also possible, such as a rack and pinion gear system for example, wherein the rack is disposed along the surface of the platform base **11**.

25 In the embodiment shown in the figures, the lateral sides of the track **24** are provided with a plurality of transverse holes **28** (best seen in Figure 3), each configured for insertion of a locking pin (not shown) whose function is to prevent unwanted movement of the ridged wheels **26** along the tracks **24**. Each ridged wheel is contained within a housing **30** which holds the axle (not shown)
30 of the ridged wheel **26**. The housing **30** also has at least one transverse hole **31** that can be substantially aligned with any one of the other transverse holes **28** along the track **24**. The housing **30** can be locked to a position along the track

- 5 -

24 by insertion of a locking pin (not shown), through the aligned holes **28**, thereby preventing movement of the ridged wheel along the track **24** as described previously.

Each housing **30** is connected to a leg **32** that supports one of the four corners of the platform support frame **12**. The entire platform support frame **12** is thereby moveable along the tracks **24**. Advantageously, the construction of the platform support frame **12** is such that one or two workers can push it along the tracks **24** from the forward working position to a rearward retracted position to allow for repair or exchange of equipment at the wellhead.

10 It is notable that all three levels of the platform system **10** each have a gap that is intended to accommodate the wellhead with its associated equipment. The platform base **11** has a base wellhead access gap **34** that remains fixed in position with the fixed position of the platform base **11**. The platform support frame **12** has a support frame wellhead access gap **36** and the
15 upper platform **13** has an upper platform wellhead access gap **38** which is substantially aligned with the support frame wellhead access gap **36**. Gaps **36** and **38** remain aligned and move cooperatively when the platform support frame **12** is moved along the tracks **24**. It is also notable that the tracks **24** extend into forward portions of the platform base **11** adjacent to the base
20 wellhead gap **34**. This allows the platform support frame **12** and the cooperating upper platform **13** to be placed in a position above the wellhead so that workers can carryout workover or completion tasks thereupon.

Returning now to the platform support frame **12**, attached generally at each corner is an upper platform vertical extension means, such as a screw jack
25 **40** which may be operated through hydraulic power via a sprocket and chain drive, for example. Instead of screw jacks **40**, hydraulic cylinders (not illustrated) could be used. The platform support frame **12** further has connection points **42** for insertion of vertically-adjustable extension members
44 which may be each made up of sections that are added after the screw jacks
30 **40** vertically extend the upper platform **13**.

The upper platform **13** may be fitted with removable railing sections **46** along its outer edges. Advantageously, one such section is of a size convenient for removal and attachment in its place of a set of self-leveling stairs **47** that

- 6 -

extend to the ground or to the platform base. The railing sections **46** are inwardly foldable from the upright position to rest upon the surface of the upper platform **13**. Folding the railing sections **46** may be advantageous for situations where the platform system **10** is removed from one wellhead site and
5 transported to another site.

The upper platform **13** may also be fitted with a foldable post **48** at each corner. The post is useful for attachment of one or more safety tethers to prevent workers from injury by falling off the upper platform **13**. The foldable post **48**, when in the folded position, rests against the upper surface of the
10 upper platform **13** again as may be advantageous for situations where the platform system **10** is removed from one wellhead site and transported to another site.

The tracks **24** may be fitted with a conveniently removable outrigger bar **50** attachable at a plurality of locations along the tracks and locked to the
15 tracks at one or more holes **28** in the tracks **24**. The outrigger bar is used to stabilize the platform for windy conditions and to help stabilize the unit when it is fully telescoped. The outrigger would be located at the front end of the opening just behind the support leg **32** and a turnbuckle would be installed from the outrigger to the top of the platform support frame approximate to
20 connection point **42**.

The platform support frame **12** may be additionally fitted at its forward end with a secondary platform **52** which can be connected by horizontally adjustable members **54** connected to the platform support frame **11**. The horizontally-adjustable members **52** can be connected to vertically-adjustable
25 members **56** which are connected at their other ends to the rearward edges of the secondary platform **50**.

The foregoing discussion and description is intended to illustrate the concepts of the invention with emphasis upon the preferred embodiment or embodiments. The above description is not exhaustive of all options or
30 mannerisms for practicing the disclosed principles of the invention, the full scope of which includes this patent specification as a whole, including the claims thereof. The full scope of the invention also includes functional and mechanical

- 7 -

equivalents of elements set forth herein, including elements described explicitly or by implication as being a means for carrying out of a defined task or end.

CLAIMS

1. A movable platform system for performing workover tasks on a wellhead comprising:

an elongated platform base having front and rear ends, said front end of said platform base provided with a base wellhead access gap;

at least one track longitudinally fixed to an upper surface of said platform base, and positioned between said front and rear ends;

a platform support frame having front and rear ends, said front end of said platform support frame provided with a support frame wellhead access gap, said platform support frame movably associated with said track; and

an upper platform supported by said platform support frame, said upper platform having a front end provided with an upper platform wellhead access gap substantially vertically aligned with said support frame wellhead access gap,

said platform support frame and said upper platform movable between said front and rear ends of said platform base, thereby providing workers with both ground access and elevated access to an area surrounding said wellhead.

2. The platform system of claim 1 wherein said at least one track is a pair of parallel spaced apart tracks and said platform support frame is movably associated with each member of said pair of spaced apart tracks.

3. The platform system of claim 2 wherein said platform support frame has four corners, each having a leg coupled to a corresponding member of said pair of tracks.

4. The platform system of claim 2 or 3 wherein said pair of tracks extends to forward portions of said platform base on both sides of said base wellhead access gap.

5. The platform system of any one of claims 1 to 4 wherein said upper platform has four corners, and each of said four corners is connected to said platform support frame by an upper platform support member.

- 9 -

6. The platform system of claim 5 wherein each of said upper platform support members is vertically extendable and configured to set said upper platform at a variable height above said platform support frame.
7. The platform system of any one of claims 1 to 6 wherein said base wellhead access gap is substantially aligned with said support frame wellhead access gap and said upper platform wellhead access gap when said platform support frame is in its forwardmost position along said at least one track.
8. The platform system of any one of claims 1 to 7 wherein said platform support frame is coupled to said track with one or more wheels.
9. The platform system of claim 8 wherein said wheels have outer ridges that extend downwardly along said track's outward side.
10. The platform system of claim 8 or 9 wherein said wheels are provided with a housing having opposed lateral sides extending downwardly adjacent to sides of said wheels.
11. The platform system of any one of claims 8 to 10 wherein said track includes a plurality of transverse holes along its length, each of said holes configured for insertion of a locking pin for blocking rolling movement of said wheels along said track.
12. The platform system of claim 10 or 11 wherein said housing is provided with at a transverse hole on each side of said housing for locking said housing to said track by insertion of said locking pin through transverse holes on opposite sides of said housing and through an intervening transverse hole in said track.
13. The platform system of claim 9 further comprising an outrigger bar removably attachable to said track at a plurality of longitudinal positions along said track, said outrigger bar configured to stabilize the platform.

- 10 -

14. The platform system of any one of claims 1 to 13 further comprising one or more means for lifting said upper platform, wherein said means for lifting said upper platform is attachable to said platform support frame.
15. The platform system of claim 14 wherein said means for lifting said upper platform is a screw jack system comprising a plurality of screw jacks each extending from said platform support frame to said upper platform.
16. The platform system of any one of claims 1 to 15 further comprising a secondary platform releasably attachable to a forward portion of said upper platform support frame by a pair of horizontally-adjustable extension members.
17. The platform system of any one of claims 1 to 15 wherein said upper platform includes removable railing sections connected to edges of said upper platform, said railing sections inwardly foldable onto the surface of said upper platform for transportation.
18. The platform system of any one of claims 5 to 16 wherein each of said four corners of said upper platform includes an upwardly extending post configured for securing a safety line, said post inwardly foldable onto the surface of said upper platform for transportation.
19. The platform system of any one of claims 1 to 17 wherein said platform base includes at least one wheel at said rear end, said wheel configured to provide rolling motion along the ground, to said platform system when said base frame is lifted at its front end and moved rearwardly, thereby facilitating ground transport of said platform system.

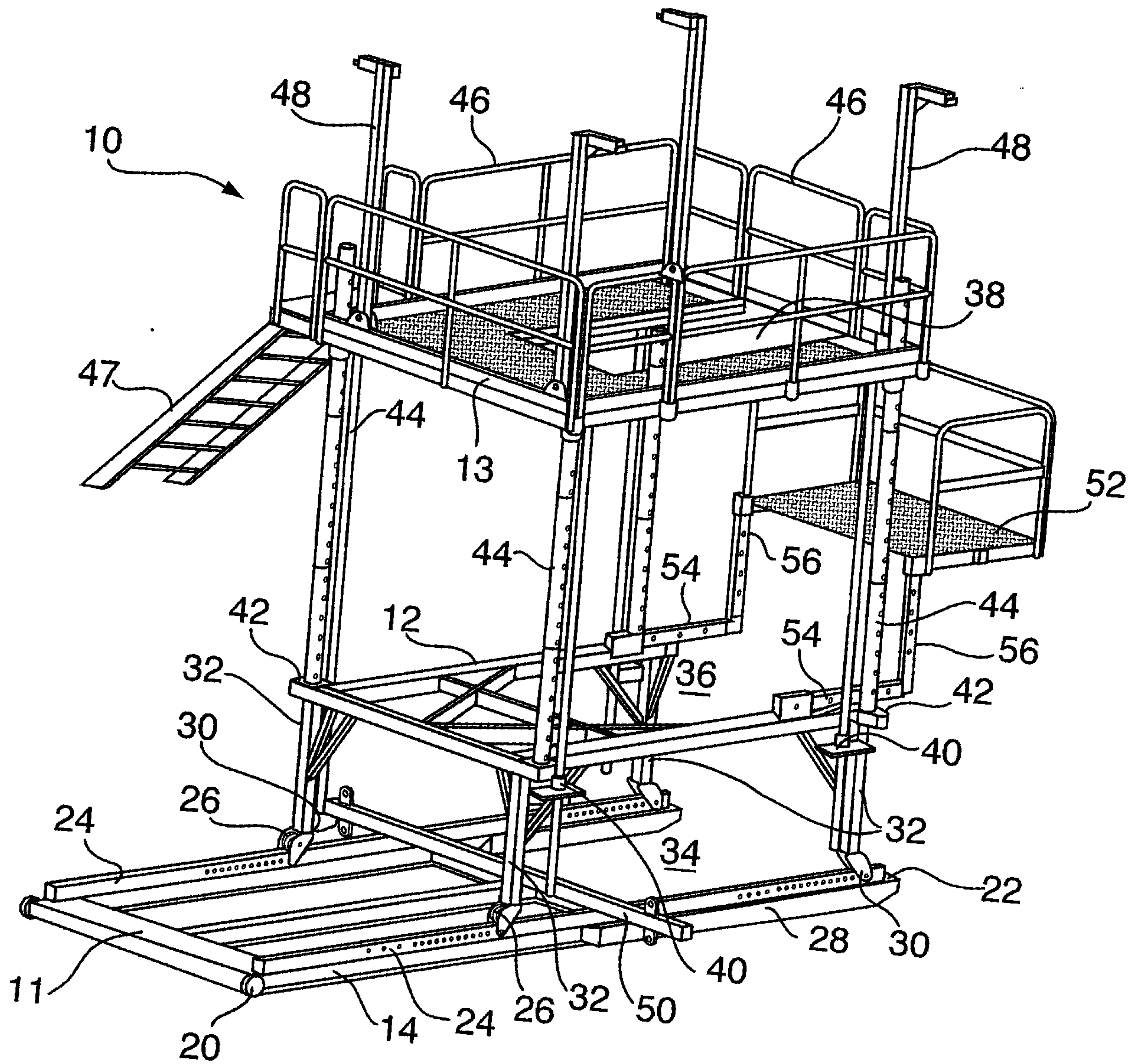

FIG. 1

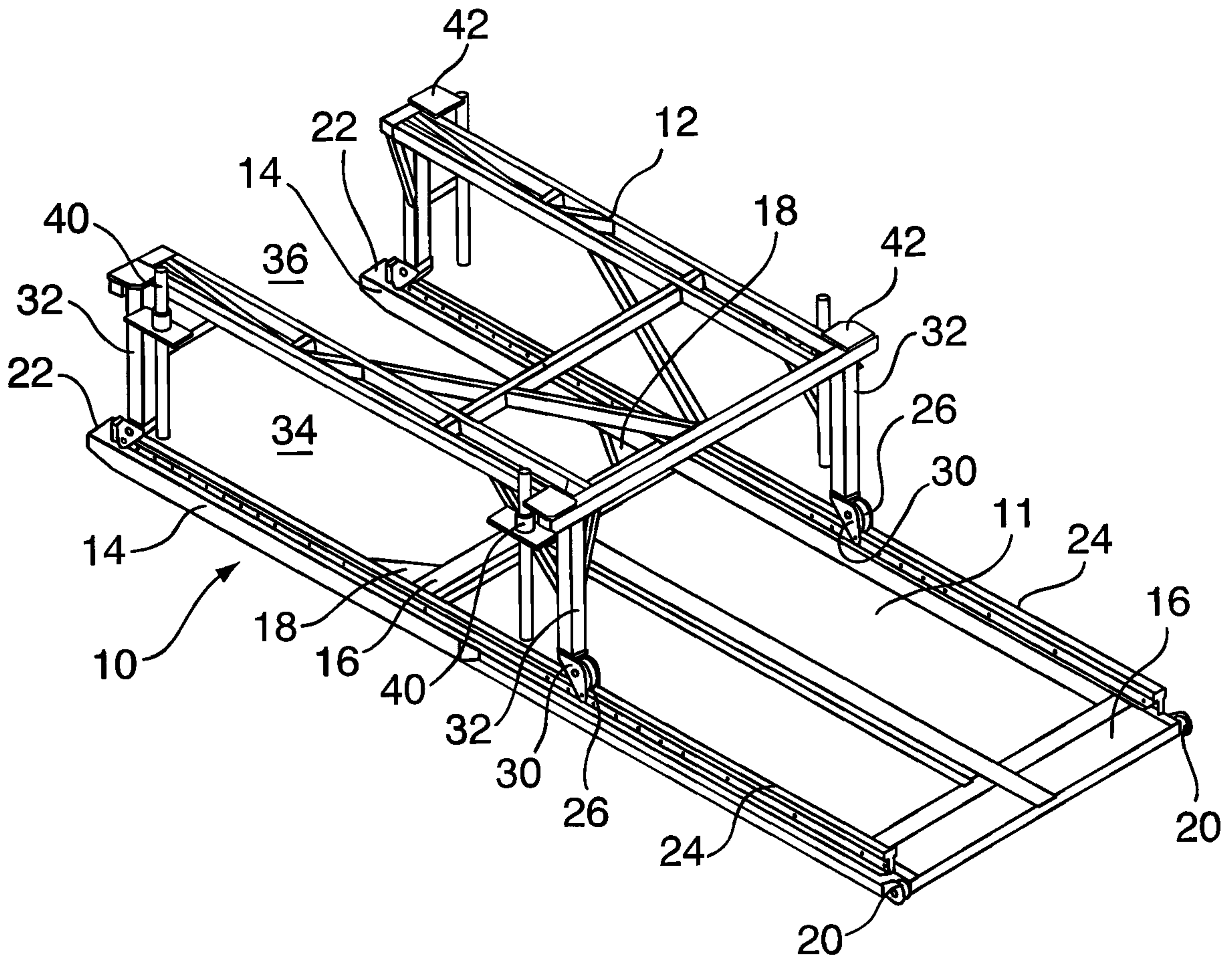

FIG. 2

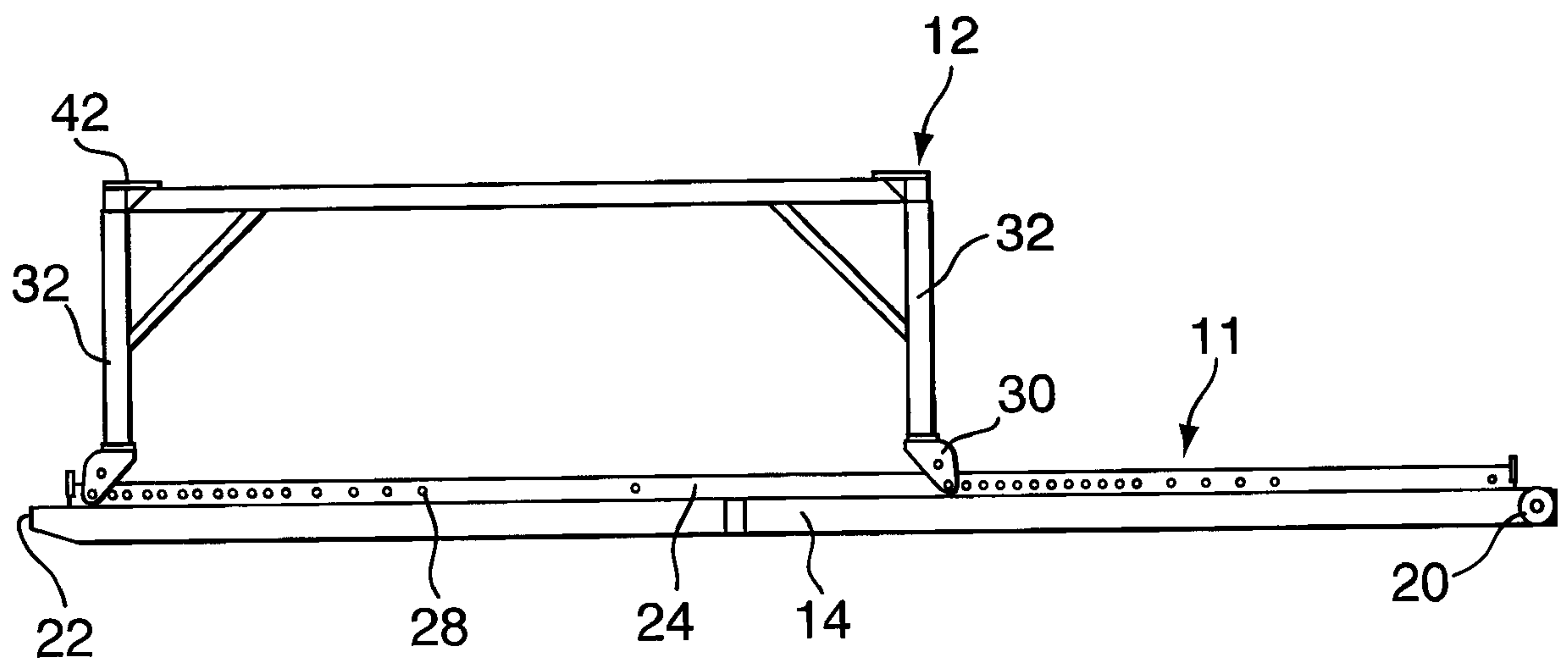

FIG. 3

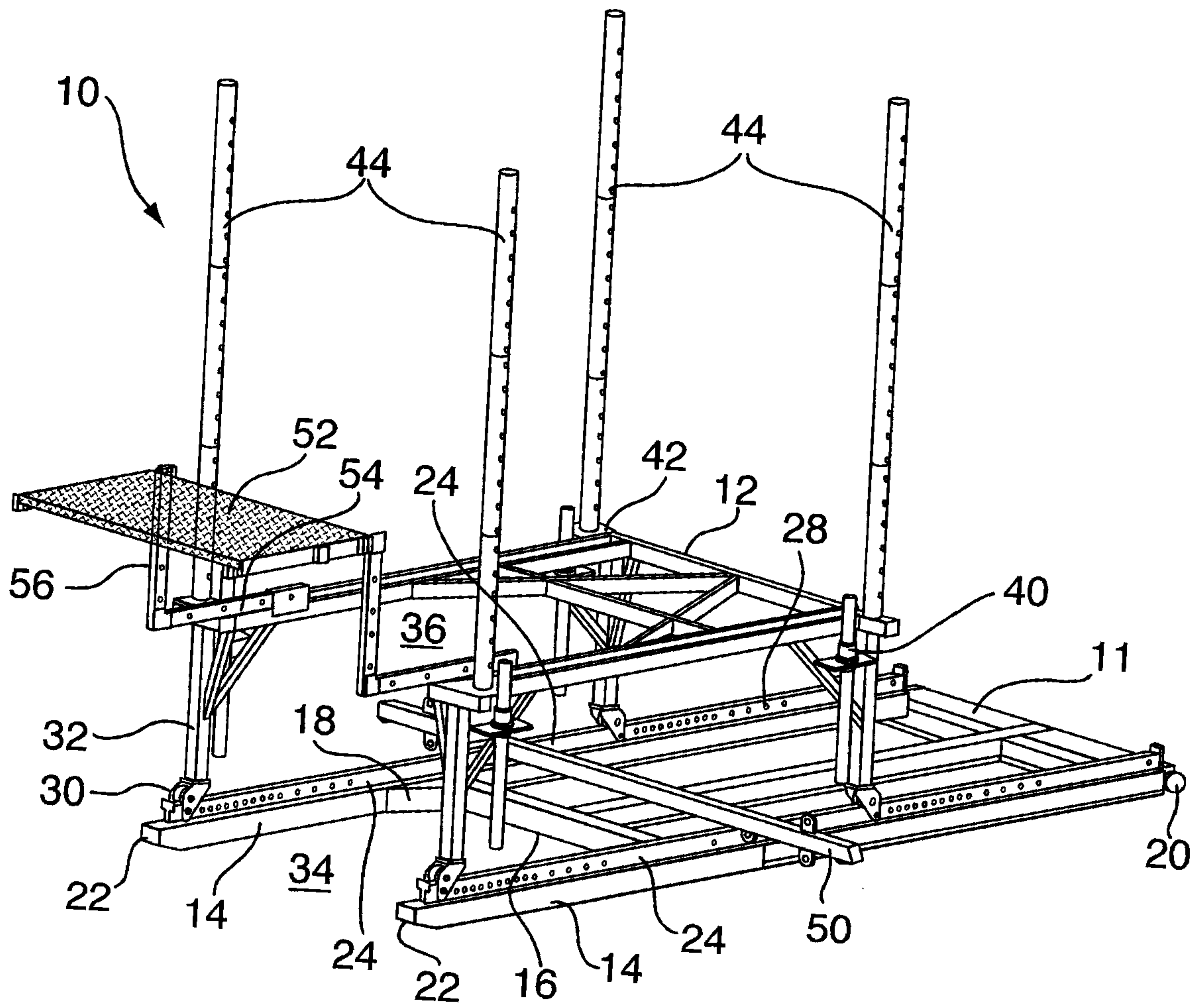

FIG. 4

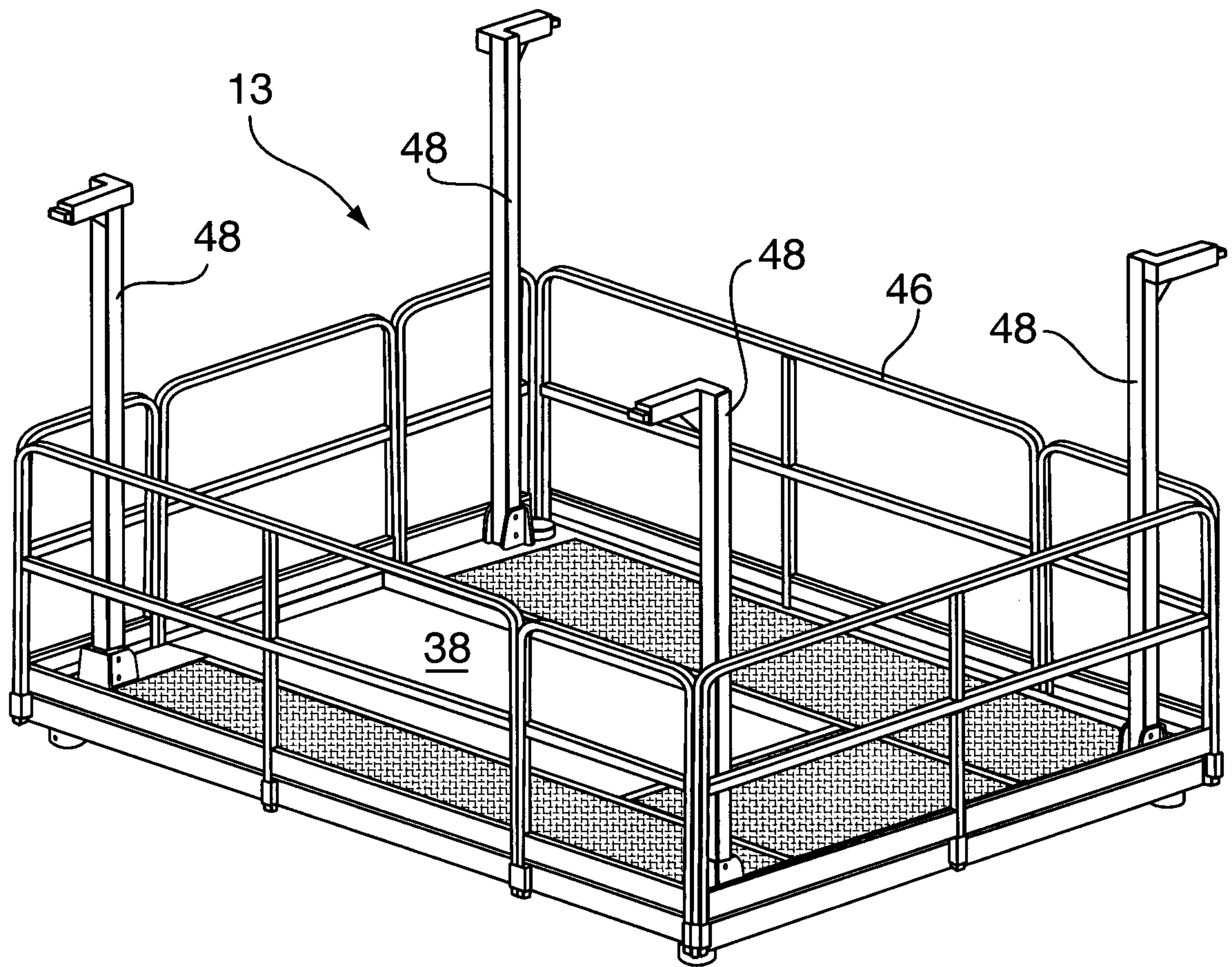

FIG. 5

