

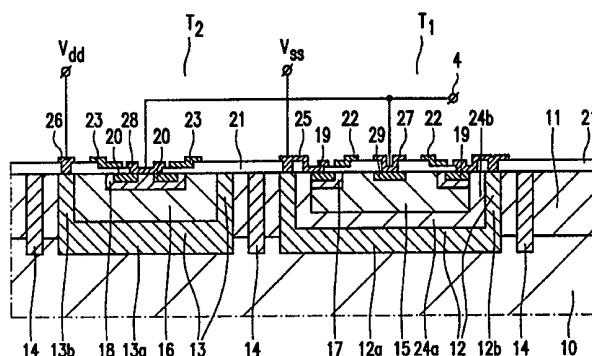

INTERNATIONAL APPLICATION PUBLISHED UNDER THE PATENT COOPERATION TREATY (PCT)

(51) International Patent Classification ⁶ : H01L 27/088, 29/78, 29/06	A3	(11) International Publication Number: WO 99/22409 (43) International Publication Date: 6 May 1999 (06.05.99)
(21) International Application Number: PCT/IB98/01589 (22) International Filing Date: 12 October 1998 (12.10.98) (30) Priority Data: 97203346.8 28 October 1997 (28.10.97) EP (71) Applicant: KONINKLIJKE PHILIPS ELECTRONICS N.V. [NL/NL]; Groenewoudseweg 1, NL-5621 BA Eindhoven (NL). (71) Applicant (for SE only): PHILIPS AB [SE/SE]; Kottbygatan 7, Kista, S-164 85 Stockholm (SE). (72) Inventor: LUDI KHUIZE, Adrianus, Willem; Prof. Holstlaan 6, NL-5656 AA Eindhoven (NL). (74) Agent: HOUBIERS, Ernest, E., M., G.; Internationaal Octrooibureau B.V., P.O. Box 220, NL-5600 AE Eindhoven (NL).		(81) Designated States: JP, KR, European patent (AT, BE, CH, CY, DE, DK, ES, FI, FR, GB, GR, IE, IT, LU, MC, NL, PT, SE). Published <i>With international search report.</i> (88) Date of publication of the international search report: 8 July 1999 (08.07.99)

(54) Title: SEMICONDUCTOR DEVICE COMPRISING A HALF-BRIDGE CIRCUIT



(57) Abstract

The invention relates to a half-bridge circuit comprising two series-connected n-channel DMOS transistors, in which the source of the one transistor, the low-side transistor T_1 , is connected to a low-voltage terminal V_{ss} , and the drain of the other transistor, the high-side transistor T_2 , is connected to a high-voltage terminal V_{dd} . The drain of the low-side transistor and the source of the high-side transistor are connected to the output terminal (4). The circuit is arranged in a semiconductor body having an n-type or p-type epitaxial layer (11) which is applied to a p-type substrate (10). In the epitaxial layer, two n-type regions are defined for the transistors, each of said regions forming a drift region of one of the transistors and being surrounded by a cup-shaped n-type zone in the semi-conductor body. Within the n-type cup-shaped zone (12) of the low-side transistor T_1 , there is provided a p-type cup-shaped zone which isolates the drift region (15) of T_1 from the cup-shaped zone (12) and which is connected, along with the cup-shaped zone (12), the backgate region (17) and the source (19) of T_1 to V_{ss} . In the high-side transistor, the n-type cup-shaped region (13) is connected, together with the drain, to V_{dd} . As in the case of the low-side transistor, the n-type cup-shaped zone is at a fixed voltage, it is precluded that electrons are injected by this zone into the substrate, and consequently, also the risk of latch-up and disturbances in the rest of the circuit is precluded. It is also precluded that, at a higher resistivity of the substrate, voltage jumps occur in the substrate, which could also give rise to latch-up and disturbances. In addition, at least the low-side transistor can be constructed in such a manner that the RESURF condition is met, thus enabling the device to be used aslo at a high voltage.

FOR THE PURPOSES OF INFORMATION ONLY

Codes used to identify States party to the PCT on the front pages of pamphlets publishing international applications under the PCT.

AL	Albania	ES	Spain	LS	Lesotho	SI	Slovenia
AM	Armenia	FI	Finland	LT	Lithuania	SK	Slovakia
AT	Austria	FR	France	LU	Luxembourg	SN	Senegal
AU	Australia	GA	Gabon	LV	Latvia	SZ	Swaziland
AZ	Azerbaijan	GB	United Kingdom	MC	Monaco	TD	Chad
BA	Bosnia and Herzegovina	GE	Georgia	MD	Republic of Moldova	TG	Togo
BB	Barbados	GH	Ghana	MG	Madagascar	TJ	Tajikistan
BE	Belgium	GN	Guinea	MK	The former Yugoslav Republic of Macedonia	TM	Turkmenistan
BF	Burkina Faso	GR	Greece	ML	Mali	TR	Turkey
BG	Bulgaria	HU	Hungary	MN	Mongolia	TT	Trinidad and Tobago
BJ	Benin	IE	Ireland	MR	Mauritania	UA	Ukraine
BR	Brazil	IL	Israel	MW	Malawi	UG	Uganda
BY	Belarus	IS	Iceland	MX	Mexico	US	United States of America
CA	Canada	IT	Italy	NE	Niger	UZ	Uzbekistan
CF	Central African Republic	JP	Japan	NL	Netherlands	VN	Viet Nam
CG	Congo	KE	Kenya	NO	Norway	YU	Yugoslavia
CH	Switzerland	KG	Kyrgyzstan	NZ	New Zealand	ZW	Zimbabwe
CI	Côte d'Ivoire	KP	Democratic People's Republic of Korea	PL	Poland		
CM	Cameroon	KR	Republic of Korea	PT	Portugal		
CN	China	KZ	Kazakstan	RO	Romania		
CU	Cuba	LC	Saint Lucia	RU	Russian Federation		
CZ	Czech Republic	LI	Liechtenstein	SD	Sudan		
DE	Germany	LK	Sri Lanka	SE	Sweden		
DK	Denmark	LR	Liberia	SG	Singapore		
EE	Estonia						

INTERNATIONAL SEARCH REPORT

International application No.

PCT/IB 98/01589

A. CLASSIFICATION OF SUBJECT MATTER

IPC6: H01L 27/088, H01L 29/78, H01L 29/06

According to International Patent Classification (IPC) or to both national classification and IPC

B. FIELDS SEARCHED

Minimum documentation searched (classification system followed by classification symbols)

IPC6: H01L

Documentation searched other than minimum documentation to the extent that such documents are included in the fields searched

SE,DK,FI,NO classes as above

Electronic data base consulted during the international search (name of data base and, where practicable, search terms used)

WPI, PAJ, EPODOC, NPC

C. DOCUMENTS CONSIDERED TO BE RELEVANT

Category*	Citation of document, with indication, where appropriate, of the relevant passages	Relevant to claim No.
A	US 5703390 A (YUKIO ITOH), 30 December 1997 (30.12.97), see whole document --	1-4
A	IEEE JOURNAL OF SOLID-STATE CIRCUITS, Volume 29, No 8, August 1994, R. Gariboldi et al, "A Monolithic Quad Line Driver for Industrial Applications", see whole document --	1-4
A	EP 0544048 A1 (SGS-THOMSON MICROELECTRONICS S.R.L.), 2 June 1993 (02.06.93), see whole document --	1-4



Further documents are listed in the continuation of Box C.



See patent family annex.

* Special categories of cited documents:

"A" document defining the general state of the art which is not considered to be of particular relevance

"E" earlier document but published on or after the international filing date

"L" document which may throw doubts on priority claim(s) or which is cited to establish the publication date of another citation or other special reason (as specified)

"O" document referring to an oral disclosure, use, exhibition or other means

"P" document published prior to the international filing date but later than the priority date claimed

"I" later document published after the international filing date or priority date and not in conflict with the application but cited to understand the principle or theory underlying the invention

"X" document of particular relevance: the claimed invention cannot be considered novel or cannot be considered to involve an inventive step when the document is taken alone

"Y" document of particular relevance: the claimed invention cannot be considered to involve an inventive step when the document is combined with one or more other such documents, such combination being obvious to a person skilled in the art

"&" document member of the same patent family

Date of the actual completion of the international search

29 April 1999

Date of mailing of the international search report

04 -05- 1999

Name and mailing address of the ISA/

Swedish Patent Office

Box 5055, S-102 42 STOCKHOLM

Facsimile No. +46 8 666 02 86

Authorized officer

Pär Moritz

Telephone No. +46 8 782 25 00

INTERNATIONAL SEARCH REPORT

International application No.

PCT/IB 98/01589

C (Continuation). DOCUMENTS CONSIDERED TO BE RELEVANT

Category*	Citation of document, with indication, where appropriate, of the relevant passages	Relevant to claim No.
A	EP 0544047 A1 (SGS-THOMSON MICROELECTRONICS S.R.L.), 2 June 1993 (02.06.93), see whole document --	1-4
A	EP 0261556 A1 (SGS MICROELETTRONICA S.P.A.), 30 March 1988 (30.03.88), see whole document -- -----	1-4

INTERNATIONAL SEARCH REPORT

Information on patent family members

07/04/99

International application No.

PCT/IB 98/01589

Patent document cited in search report	Publication date	Patent family member(s)	Publication date
US 5703390 A	30/12/97	JP 2715941 B JP 8130307 A	18/02/98 21/05/96
EP 0544048 A1	02/06/93	DE 69126618 D,T JP 5243504 A US 5444291 A	08/01/98 21/09/93 22/08/95
EP 0544047 A1	02/06/93	DE 69128936 D,T JP 5226597 A US 5449936 A	16/07/98 03/09/93 12/09/95
EP 0261556 A1	30/03/88	SE 0261556 T3 DE 3780390 A IT 208600 Z JP 2525208 B JP 63088854 A US 4890149 A	20/08/92 28/05/88 14/08/96 19/04/88 26/12/89