

Nov. 15, 1966

L. P. HYNES

3,286,078

FLEXIBLE INTERNAL HEATER

Filed April 6, 1964

2 Sheets-Sheet 1

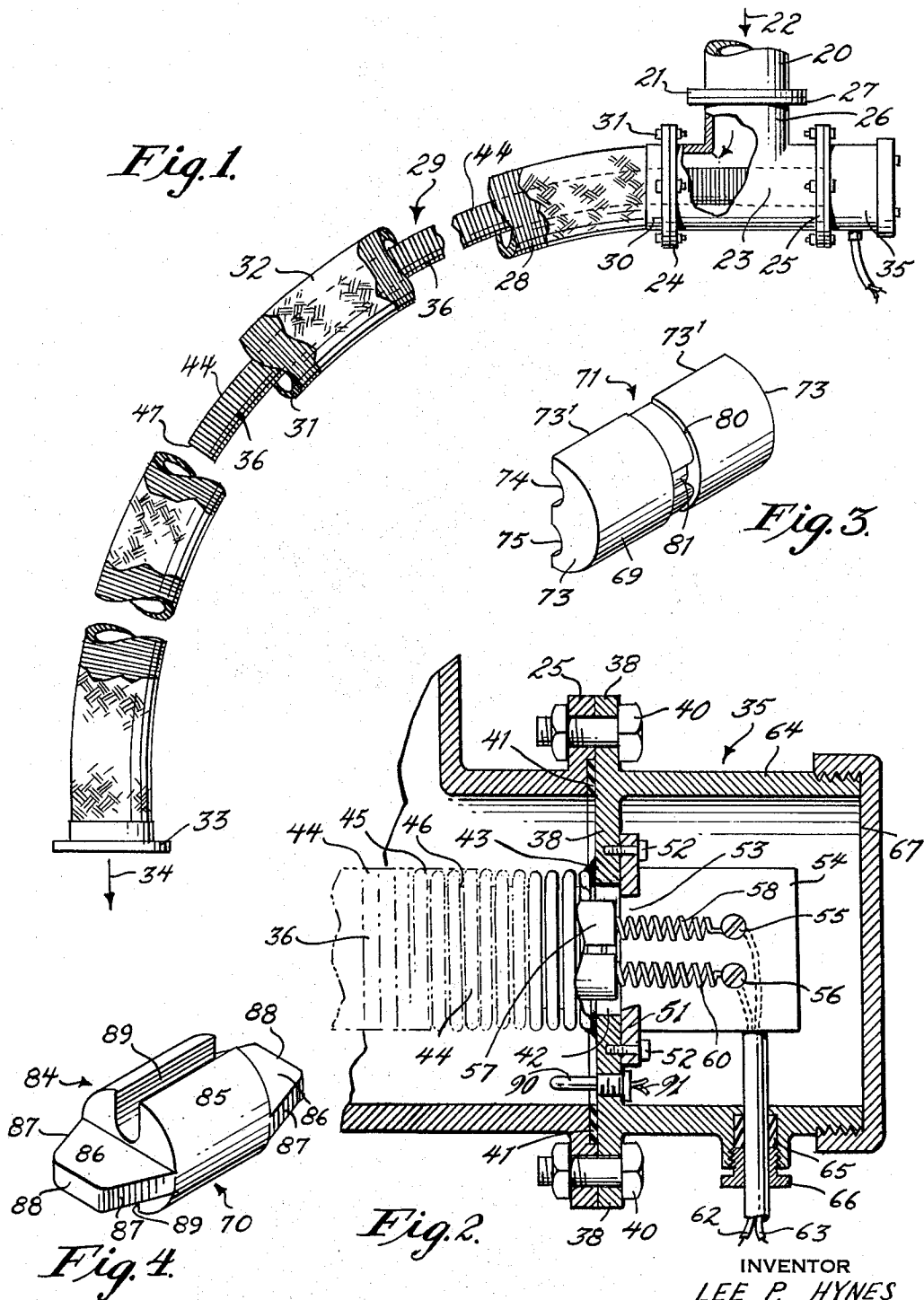

INVENTOR
LEE P. HYNES

BY 
ATTORNEYS

Nov. 15, 1966

L. P. HYNES

3,286,078

FLEXIBLE INTERNAL HEATER

Filed April 6, 1964

2 Sheets-Sheet 2

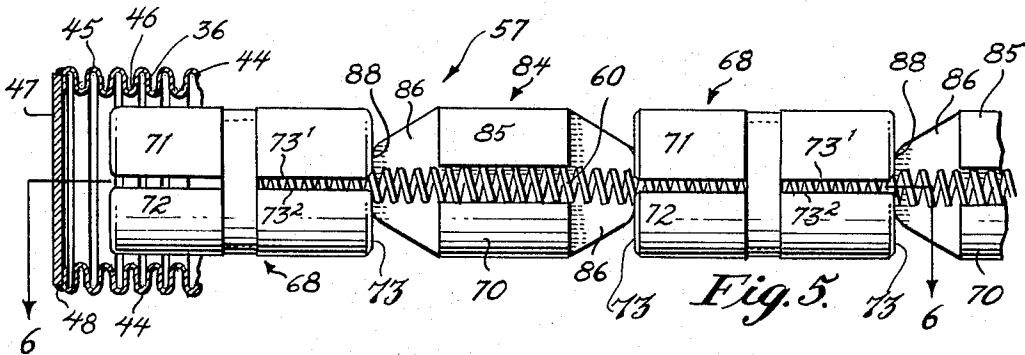

Fig. 5.

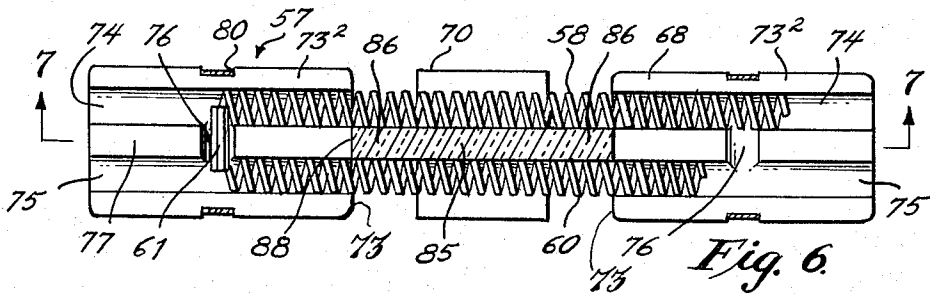

Fig. 6.

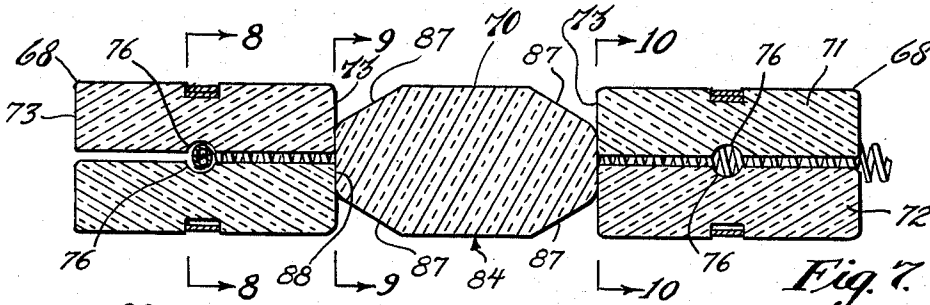

Fig. 7.

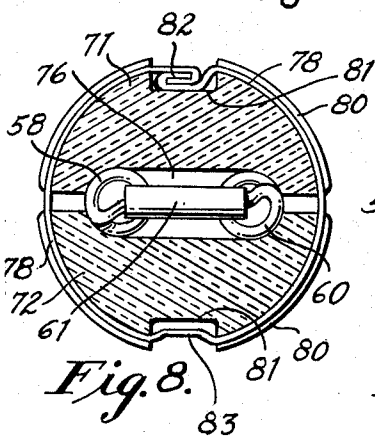

Fig. 8.

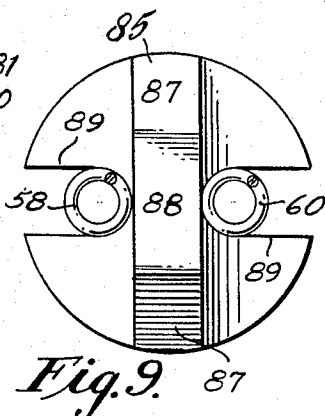

Fig. 9.

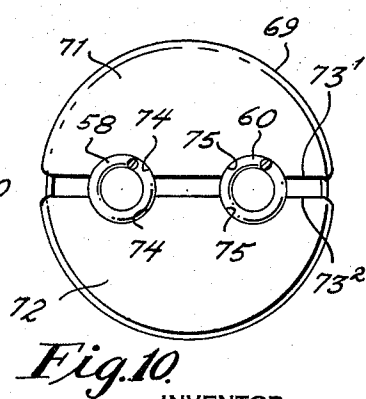

Fig. 10.

INVENTOR
LEE P. HYNES
BY
[Signature]
ATTORNEYS

1

3,286,078

FLEXIBLE INTERNAL HEATER

Lee P. Hynes, Haddonfield, N.J., assignor to Hynes Electric Heating Company, Kenilworth, N.J., a corporation of New Jersey

Filed Apr. 6, 1964, Ser. No. 357,397

2 Claims. (Cl. 219-306)

The present invention relates to electric heaters for fluids and more particularly to flexible internal heaters for fluid conduits in the form of flexible hose, bent rigid pipe, or other irregular shapes.

A purpose of the invention is to provide an electric heater which can be used internally within a fluid conduit in the form of a flexible hose or bent rigid tubing.

A further purpose of the invention is to provide a flexible electric heater which can be readily inserted within or withdrawn from a flexible hose or bent rigid tubing.

A further purpose of the invention is to provide a flexible electric heater wherein the heater elements can be readily inserted and withdrawn from an enclosure in the form of a flexible metal tubing.

A further purpose is to provide an electric heater which has a high flexibility and great resistance to fatigue failure from repeated bending.

A further purpose of the invention is to provide insulators which support and space resistors from a flexible metal tubing while allowing flexibility of the resistors and insulators to accommodate the contour and bending of the hose.

A further purpose of the invention is to provide a flexible electric heater which is positioned inside a hose.

A further purpose of the invention is to provide a flexible heater for the inside of a hose wherein the resistor elements can be readily removed and inserted into a flexible metal tubing.

A further purpose is to provide an electric heater wherein heater elements can be chosen to achieve performance characteristics over a wide range of requirements, including wattage, voltage, and temperature.

A further purpose is to provide an electric heater which can be readily assembled to any length specification.

A further purpose is to use commercial flexible metal tubing in a flexible electric heater.

A further purpose is to provide a heater for vaporizing fluids.

A further purpose is to provide a flexible sealed heater for normally inaccessible locations and irregular shaped areas where heat is required.

A further purpose of the invention is to utilize repetitive insulator elements and continuous lengths of resistors and flexible metal tubing in a flexible internal heater to satisfy a wide variety of requirements.

A further purpose is to provide a flexible heater having a standard flexible casing which can be readily assembled with a selected resistor to provide any desired heat output with available voltage.

A further purpose is to provide ease of assembly and disassembly when replacing elements.

A further purpose is to use rigid insulator supports in the form of matching semi-cylindrical elements bound together with an enclosing strap, binder or band.

A further purpose is to provide recesses in the insulator into which the band or binder can be depressed from its normal curvature to provide tension on the band.

A further purpose is to recess a band or binder into an insulator to keep the band or binder below the surface of the insulator and to prevent interference with the flexible metal tubing.

A further purpose is to use rigid insulator segments in a flexible heater which are in pivotal relationship to one another along the resistors.

2

Further purposes appear in the specification and in the claims.

In the drawings I have chosen to illustrate a few only of the numerous embodiments in which my invention may appear, selecting the forms shown from the standpoints of convenience in illustration, satisfactory operation and clear demonstration of the principles involved.

FIGURE 1 is a fragmentary view of the hose and heater of the invention.

FIGURE 2 is an enlarged sectional view of the upstream end of the heater and housing.

FIGURE 3 is a perspective view of one half of a fulcrum insulator used in the invention.

FIGURE 4 is a perspective view of a pivot insulator used in the invention.

FIGURE 5 is a fragmentary view partly sectional of the downstream end of the heater.

FIGURE 6 is a section taken on the line 6-6 of FIGURE 5.

FIGURE 7 is a section taken on the line 7-7 of FIGURE 6.

FIGURE 8 is an enlarged axial section taken on the line 8-8 of FIGURE 7.

FIGURE 9 is a section taken on the line 9-9 of FIGURE 7.

FIGURE 10 is an enlarged section taken on the line 10-10 of FIGURE 7.

Describing in illustration but not in limitation and referring to the drawings:

The present invention is concerned with heating fluids in conduits in the form of flexible hose, bent rigid tubing, or other irregular shapes, where the conduit is generally of metal.

The invention will be explained, for purposes of clarity, in use with a flexible hose, but it should be understood that the same principles apply to the other uses, including those stated above. Flexible hoses are extensively used for loading and unloading fluids between transport vehicles and fixed pipe lines or reservoirs. Transport vehicles include ships, railroad tank cars, barges, and tank trucks.

These flexible hoses are normally exposed to the weather during use. When the weather is cold, the fluids in the hose often tend to solidify or freeze, so that flow is greatly restricted or stopped. For instance, materials such as tal- lows, greases, waxes, pitch, asphalt, heavy chemicals, and the like solidify readily at the cooler temperatures and flow is not possible.

In the prior art, efforts have been made to heat these hoses in order to soften or condition the fluids for more ready flow. These efforts included steam or flame torches applied to the outside of the hose to get flow started. This has been unsatisfactory because of lack of control, creation of a fire hazard, and substantial loss of heat to the atmosphere. In other instances, tracer lines have been used along the outside of the hoses but these have been unsatisfactory because of the difficulty of installation, maintenance, and protection from external damage.

In most prior art efforts, the heat has not been applied where most necessary, namely, on the inside of the hose in the fluid being conveyed. Prior art internal heaters have included those shown in my United States Patent 2,750,487 and 2,963,539, where a small degree of flexibility is obtained by using a longitudinal supporting strap along one side of the insulators. However, such heaters were not sufficiently flexible for use in flexible hoses or irregularly bent rigid pipes which are commonly used in conveying fluids, particularly from or to transport vehicles.

In the heater of the present invention, a flexible metal tubing containing insulated flexible resistors extends within the flexible hose conduit and heats the fluid within

the hose conduit. The upstream end of the heater is anchored at a T-connection, and suitable electrical leads are attached to the heater at that point. The downstream end of the flexible heater is allowed to float freely within the hose. The flexible metal tubing of the heater is entirely closed so that complete isolation of the live resistors of the heater from the fluid is obtained. In this way, the action of the resistors is not interfered with and the fluid is not contaminated. The assembly of insulated resistors can be readily inserted and withdrawn from the flexible metal tubing while the heater is in position within a hose, or, in the alternative, the entire flexible heater including the flexible metal tubing and insulated resistors can be withdrawn from the hose. The resistors are flexibly insulated and supported within the flexible metal tubing by repetitive, alternate, pivoted, rigid, insulators.

As shown in the drawings and referring to FIGURE 1, fluid flows from any suitable source through the conduit 20 in the direction shown by the arrow 22. This fluid can be of any type including heavy oils, greases, waxes, pitch and many other materials. A T-connection 23 having side outlets 24 and 25 is connected at 26 by means of a suitable flange 27 to flange 21 of the supply conduit 20. A conventional flexible hose 28, generally metallic, having a flange 30 is bolted by means of bolts 31 to the flange 24 of T26. The flexible hose 28 can be, for instance, of a type having an inner transversely corrugated structure 31 and an outer braided metal cover 32. The hose can extend for any suitable length and has at its downstream end a flange 33 or other connector, or, in other instances, a plain end which can be used for pouring or discharging into a suitable vessel. The material which enters at 22 flows out of the flexible hose at 34 in the direction shown by the arrow. The conduit 20 and hose 28 are of conventional prior art construction.

The heater 29 of the invention is inserted through T26 into hose 28 through side outlet 25. The heater 29 of the invention consists of a terminal portion 35 and a heater portion 36. Terminal portion 35 as seen in FIGURES 1 and 2 includes a flange 38 which is held to flange 25 by bolts 40. A suitable gasket 41 provides a fluid seal between flanges 25 and 38. The flange 38 has a central annular opening 42 which has secured and sealed thereto at 43 a flexible metal tubing 44. The flexible metal tubing 44 can be of any suitable type, for instance, one having alternate corrugations of extensions 45 and depressions 46 in a well known bellows fashion. Metal tubing of this type has excellent flexibility and resistance to kinking. The tubing 44 is secured in opening 42 at 43 as by welding or other means to provide a completely fluid tight connection to the flange 38. At the downstream end toward discharge 34, flexible tubing 44 has a sealed end cap 47 as best seen in FIGURE 5 which is welded to the flexible metal tubing 44 at 48. By means of the seal at 43 and the seal at 48, the interior of flexible tubing 44 is completely isolated from the fluid flow which occurs in the hose 28 from the inlet 22 to the outlet 34. The flexible metal tubing 44 can be made of any desired length.

Considering now the terminal portion 35, a flange 51 is secured to flange 38 by means of cap screws 52. Flange 51 has an annular opening at 53. Flange 51 has integral therewith terminal block 54 mounting insulated electrical terminals 55 and 56.

Extending within flexible metal tubing 44 is a heating element 57. The heating element 57 consists of resistors 58 and 60 which are shown as being helically wound but which may be of any suitable type. The resistors 58 and 60 may be for instance, of a round cross section wire or of a flat ribbon. The resistors are connected at terminal portion 35 to terminals 55 and 56. At the other end of the heater element 57 as best seen in FIGURE 6, the resistors 58 and 60 are suitably spliced by means of a metal element 61 either welded or crimped

to the end of the resistors. Alternatively, the resistors 58 and 60 could be integral and merely bent rather than spliced.

Suitable electric leads 62 and 63 pass through terminal box 64 which is suitably integral with flange 38. Leads 62 and 63 pass through packing 65 and follower 66 to make a waterproof connection. A cap 67 is screwed onto terminal box 64 to provide a weatherproof enclosure for the entire electrical assembly and prevent moisture or other foreign matter from entering the terminal box 64 as well as the interior of the flexible metal tubing 44.

The resistors 58 and 60 are supported and spaced within flexible metal tubing 44 by fulcrum insulators 68 and pivot insulators 70. Considering first the fulcrum insulators 68, each insulator consists of two identical semi-cylindrical portions 71 and 72. Since the halves 71 and 72 are identical, only one half 71 as best seen in FIGURE 3 will be described in detail. Portion 71 has a curved surface 69 and opposing flat ends 73. Additionally, resistor half 71 has a flat, longitudinally extending plane surface 73' which extends in spaced parallel relationship with a flat surface 73² on an opposed half 72. Suitable semi-circular channels or grooves 74 and 75 as best seen in FIGURES 3 and 6 extend longitudinally of the insulator halves 71 and 72 and are of a size which properly grips and supports the resistors 58 and 60. Each of the portions 71 and 72 of the fulcrum insulators 68 has a transverse groove 76 which is adapted to receive the connector 61 at the end of the resistors, which serves to connect the resistors together at the end opposite the terminals 55 and 56. It will be evident that although all of the fulcrum insulators will carry such transverse grooves, only the endmost fulcrum insulator will be utilized for the purpose of cross connecting the resistors. This is clearly shown in FIGURE 6 where the end of the insulator away from the resistor as at 77 acts as a suitable barrier for insulating the end of the resistor at 61 away from the flexible tubing 44 at the end cap 47.

Matching fulcrum insulator halves 71 and 72 are held in spaced gripping relationship about the resistors 58 and 60, as best seen in FIGURE 8, by a band or strap 78 which lies in a recessed groove 80 which extends annularly around the longitudinal midsection of the insulator halves 71 and 72.

The groove 80 has recesses or slots 81 below groove 80 at a position midway on the circumference, the slot being best seen in perspective in FIGURE 3 and in section in FIGURE 8. The slot receives in one instance a splice 82 suitably in the form of bent interlocked ends of the band 78 depressed into the slot. In a slot 81 opposite to the splice 82, the band is depressed as at 83 into the slot to achieve a tensioning of the band during or after the splice 82 is completed. Both the splice 82 and the depression 83 may be performed by any suitable tool, such as clamps, vices or opposed jaws. It should be understood that splice or joint 82 is merely illustrative and that band 78 could be spliced by any suitable means such as spot welding or other fastenings.

In applying the band 78 and also in the subsequent splicing and tensioning by means of depression 83, the insulators 71 and 72 grip the resistors 58 and 60 securely in their longitudinally extending grooves 74 and 75 in a resilient but firm manner, whereby relative longitudinal movement between the fulcrum insulators 68 and the resistors 58 and 60 is prevented.

Pivot insulators 70, as best seen in FIGURE 4, are alternately spaced between the fulcrum insulators 68, as shown in FIGURES 5 to 7. The pivot insulator 70 consists of a cylindrical portion 85 and abutment portions 86 suitably integral with portion 85. The abutment portion 86 is tapered at 87 with an end abutment at 88. The portion 85 has extending therethrough longitudinally extending opposed slots 89 which receive the resistors 58 and 60 as best seen in FIGURES 5, 6 and

5

9. The resistors 58 and 60 resiliently abut against the inner portions of the slots 89 so that the pivot insulator 70 is firmly held positioned between the fulcrum insulators 68 but is not fixedly connected thereto. The resistors 58 and 60 serve to resiliently hold insulators 68 and 70 in abutting relationship at faces 73 and 88 respectively while allowing the insulators 68 and 70 to pivot in a universal direction with respect to one another at these faces to achieve flexibility as flexible tubing 44 bends to conform to the contour of flexible conduit hose 28.

The abutment portion 86 of pivot insulator 70 additionally serves as an insulating barrier between resistors 58 and 60 at all times, as shown particularly in FIGURES 6 and 9, whether the heater 29 is flexed or in a straight position.

A temperature sensing device 90 with suitable leads 91 may be inserted through, or attached to, the surface of the flow conduit at any desired location to sense the fluid temperature for control purposes.

In operation, the connection between the inlet conduit 20 and the flexible hose 28 is provided by a T-connection 23 having flanges on each end as described above. The heater portion 36 of flexible heater 29 is inserted into the side opening of the T-connection 23 at 25 and pushed into the interior of the flexible hose 28. The heater portion 36 is pushed into the hose until the flange 38 of the terminal portion 35 abuts against flange 25 and the flanges are bolted together by bolts 40. The heater portion 36 will have already inserted within flexible metal tubing 44, the assembly of the resistors 58 and 60 and the insulators 68 and 70 as taught in the description above. The resistors 58 and 60 will be connected to terminals 55 and 56 as by screw connections and suitable electric current will be applied to the resistors through conductors 62 and 63. The end cap 67 is then threaded onto the terminal box 64 so that the electrical connections as well as the resistors and insulators are fully protected against moisture and other elements.

In assembling the resistors and insulators prior to insertion into flexible tubing 44, the fulcrum insulators 68 are applied to the resistors by assembling the halves 71 and 72 in opposed relationship as shown, for instance, in FIGURE 8 and the band 78 applied in place around each pair of insulators in the groove 80. The band is then spliced at 82 and the band 78, at a diametrically opposed position is then depressed at 83 to apply the proper tension to the band. A pivot insulator 70 is placed adjacent the fulcrum insulator 68 into a position described above. Another fulcrum insulator 68 is brought into position in abutting relationship as shown in FIGURES 5 to 7. The second fulcrum insulator is then held in position around the resistors by applying the band 78 in a manner already described. Alternate fulcrum and pivot insulators are applied along the entire length of the resistors. Fulcrum insulators are used at both ends of the assembly. The pivot insulator 70 is then confined between a pair of fulcrum insulators 68 and the resistors 58 and 60 so that it is kept securely in position while allowing freedom of movement of the resistors, so that the pivot insulators can toggle at both ends against the fulcrum insulators. This provides desired flexibility throughout the length of the resistors to conform to the contour of the flexible metal tubing 44 which in turn conforms to the changing contour of the flexible hose 28.

It will be seen that by removing bolts 40, the entire heater 29 can be removed from its installation in flexible hose 28 by merely withdrawing the entire terminal portion

6

35 which in turn withdraws the flexible metal tubing 44 which is permanently attached thereto. In the event that it is further desired to withdraw the heater element 57 from within the flexible metal tubing 44, it is merely necessary to unscrew cap 67, remove the connections of leads 62 and 63 from terminals 55 and 56, and remove cap screws 52 from flange 38. Terminal block 54, with integral flange 51, and heater element 57 may then be withdrawn from within flexible tubing 44. Suitable replacements can be made of, for instance, the resistor elements where different requirements have to be met by the heater. In the event that it is desired to change the heat output of the heater element, or if the resistors or other parts should fail, they can be readily replaced by disassembling and reassembling with new resistors or replacement parts without disturbing any fluid connections.

In view of my invention and disclosure, variations and modifications to meet individual whim or particular need will doubtless become evident to others skilled in the art, to obtain all or part of the benefits of my invention without copying the structure shown, and I, therefore, claim all such insofar as they fall within the reasonable spirit and scope of my claims.

Having thus described my invention what I claim as new and desire to secure by Letters Patent is:

1. In a flexible fluid heater adapted to extend within a fluid enclosure through an opening in the fluid enclosure, a terminal portion, a flexible, bendable, metallic tube secured to said terminal portion at one end and closed at the other end whereby fluid is prevented from entering into the metallic tube, flexible, bendable, substantially longitudinally non-stretchable and longitudinally non-compressible, self-supporting, parallel resistors extending longitudinally within the tube and extending into the terminal portion, rigid sectional fulcrum insulators spaced longitudinally along the resistors, each of the said insulators comprising radial sections with resistor receiving portions within the sections, and tensioning means on each of the insulators for securely holding each of the insulators in secure gripping relationship to the resistors; each of said insulators having an outer radial surface generally conforming in shape to the inner surface of the metal tube, said insulator outer surface and said tube inner surface being in bearing relationship, wherein the resistors are free to bend at positions longitudinally between fulcrum insulators and are securely gripped and held within the fulcrum insulators.

2. A heater of claim 1, in combination with pivot insulators extending longitudinally between the fulcrum insulators, said pivot insulators having longitudinal grooves adapted to receive the resistors in longitudinal sliding relationship thereto.

References Cited by the Examiner

UNITED STATES PATENTS

1,699,323	1/1929	Apfel	219—306
1,829,785	11/1931	Christian	219—335
2,058,769	10/1936	Brown	219—331 X
2,064,248	12/1936	Doyon	219—331
2,888,546	5/1959	Kinney	219—528 X
2,963,539	12/1960	Hynes	174—138.8
3,016,441	1/1962	Hackman et al.	174—138.8 X
3,017,688	1/1962	Cummings et al.	338—214 X

FOREIGN PATENTS

398,589	9/1933	Great Britain.
32,387	3/1934	Netherlands.

RICHARD M. WOOD, *Primary Examiner.*

C. L. ALBRITTON, *Assistant Examiner.*