

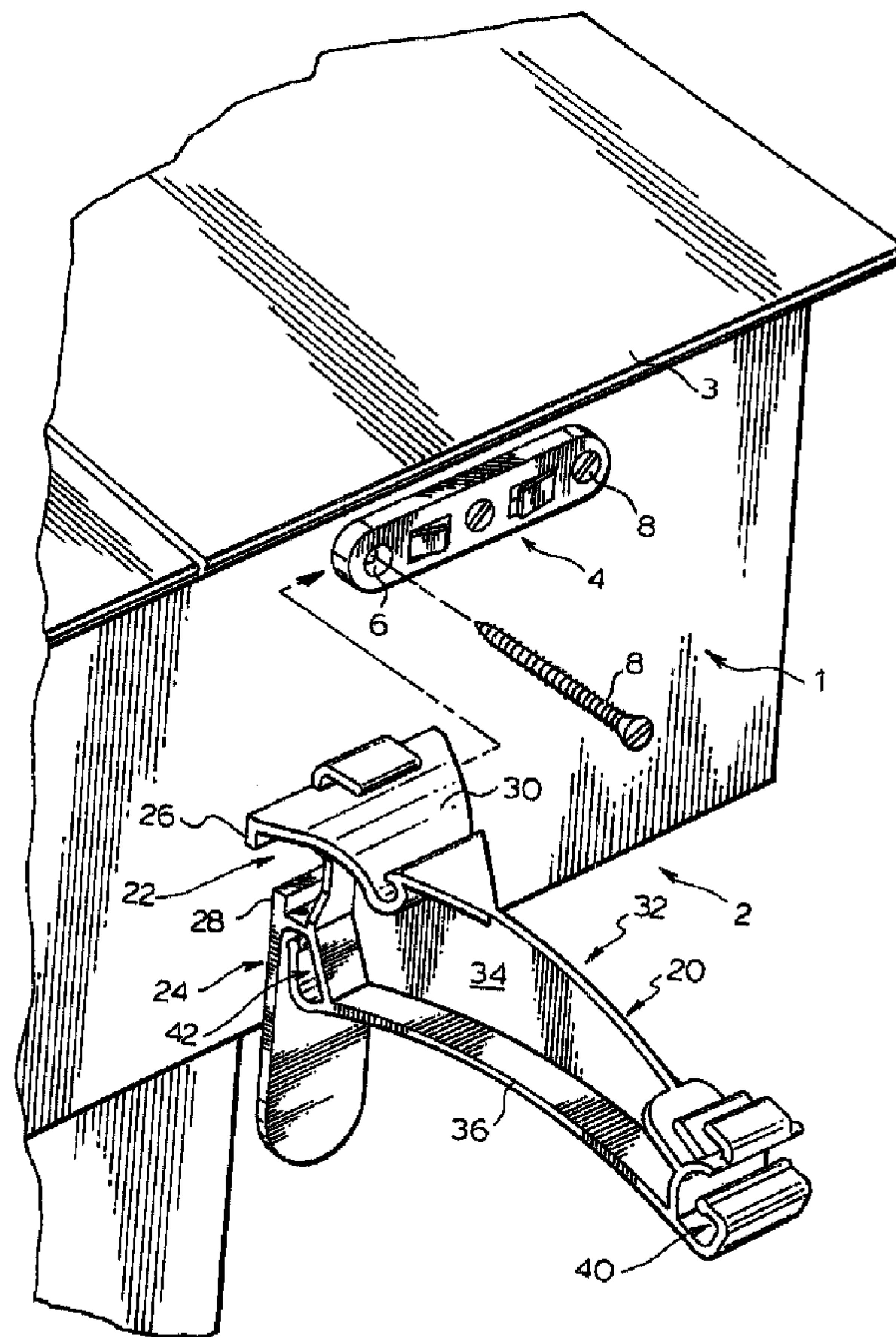

(22) Date de dépôt/Filing Date: 1996/11/29
 (41) Mise à la disp. pub./Open to Public Insp.: 1998/05/29
 (45) Date de délivrance/Issue Date: 2005/11/08
 (62) Demande originale/Original Application: 2 191 642

(51) Cl.Int.⁷/Int.Cl.⁷ E04D 13/072, F16B 1/00
 (72) Inventeur/Inventor:
 FORTIN, GARY WAYNE, CA
 (73) Propriétaire/Owner:
 GSW INC., CA
 (74) Agent: DENNISON ASSOCIATES

(54) Titre : SUPPORT DE GOUTTIERE
 (54) Title: EAVESTROUGH BRACKET ASSEMBLY



(57) Abrégé/Abstract:

An eavestrough bracket assembly uses a two-piece sliding structure for mounting the eavestrough bracket to a fascia board. The eavestrough bracket has a back face with an undercut securing slot extending across the back face. This slot receives a mounting

(57) Abrégé(suite)/Abstract(continued):

member which has been previously secured to the fascia board. The bracket and mounting member are releasably held in a securing position. Preferably, the mounting member is an elongate member secured by a plurality of screws to the fascia board.

ABSTRACT OF THE DISCLOSURE

An eavestrough bracket assembly uses a two-piece sliding structure for mounting the eavestrough bracket to a fascia board. The eavestrough bracket has a back face with an undercut securing slot extending across the back face. This slot receives a mounting member which has been previously secured to the fascia board. The bracket and mounting member are releasably held in a securing position. Preferably, the mounting member is an elongate member secured by a plurality of screws to the fascia board.

TITLE: EAVESTROUGH BRACKET ASSEMBLY

FIELD OF THE INVENTION

5 The present invention relates to an eavestrough
bracket assembly for supporting an eavestrough to one side
of a fascia board. In particular, the invention relates to
an eavestrough bracket assembly comprising a mounting
member for attachment to a fascia board and an eavestrough
hook adapted to be secured from the mounting member.

10

BACKGROUND OF THE INVENTION

15 There are many systems for securing of eavestroughs
from a fascia board and many of these systems can be
divided into systems which use metal components or systems
which use plastic components. One of the critical steps in
installing an eavestrough system is to secure the
eavestrough sections at various points along their length
in a desired manner to ensure proper drainage.
Essentially, all installation procedures include setting a
20 particular grade line along the fascia board and then
securing eavestrough hooks at appropriate positions. Some
systems allow these eavestrough hooks to be secured first
to the fascia board and then the eavestrough secured to the
hooks, or in other cases, the eavestrough hooks are
25 essentially secured when the hooks are already attached to
the eavestrough.

30 To simplify the installation process, one of our
earlier systems included securing a mounting tab to the
fascia board and these mounting tabs were adapted to
receive and support the eavestrough hook. In this way, the
mounting tabs could be secured to the fascia board and then
the eavestrough sections and eavestrough hooks could be

secured to the various mounting tabs. The eavestrough hooks were secured within a V-shaped slot of the mounting tab and the mounting tab included detent members for holding the eavestrough hook in position. Under certain
5 high load conditions, there could be failure of these mounting tabs. In addition, because the eavestrough hooks were inserted into the tabs from above, the eavestrough section could not be as close to the shingles of the roof as may be desirable. Furthermore, the eavestrough sections
10 were spaced off of the fascia board by the thickness of the back face of the tab and there was a gap between the back of the eavestrough section and the fascia board.

The present invention seeks to overcome a number of the above deficiencies while continuing to provide a system
15 which is easy to install.

SUMMARY OF THE INVENTION

An eavestrough bracket assembly according to the present invention comprises a mounting member to be secured
20 to a fascia board, an eavestrough hook adapted to be supported from the mounting member in a perpendicular manner to one side thereof. The eavestrough hook includes a back face having an undercut securing slot extending across the back face, which slidably receives the mounting
25 member and releasably secures the hook to the mounting member.

According to an aspect of the invention, the eavestrough bracket assembly has a mounting member which is elongate with securing shoulders extending in the
30 longitudinal direction of the mounting member, which shoulders are received in and form an overlap region with the undercut securing slot.

According to yet a further aspect of the invention, the mounting member includes at least one spring tab which

cooperates with the eavestrough hook to positively locate and retain the hook on the mounting member.

According to yet a further aspect of the invention, the mounting member has two spring tabs which locate the eavestrough hook between the spring tabs.

According to yet a further aspect of the invention, the mounting member includes at least two ports spaced in the length of the mounting member, which ports receive fasteners for securing the mounting member to a fascia board.

According to yet a further aspect of the invention, the mounting member is generally flush with the back face of the eavestrough hook when the mounting member is received in the eavestrough hook. With this arrangement, the eavestrough section is in close proximity to the fascia board.

BRIEF DESCRIPTION OF THE DRAWINGS

Preferred embodiments of the invention are shown in the drawings, wherein:

Figure 1 is an exploded perspective view of the eavestrough hook assembly being attached to a fascia board;

Figure 2 is a side view showing an eavestrough section supported from the eavestrough bracket assembly;

Figure 3 is a perspective view showing the rear surface of the mounting member and the back face of the eavestrough hook;

Figure 4 is a partial perspective view showing an eavestrough section and the manner of securement to the eavestrough hook;

Figure 5 is a sectional view through the mounting member;

Figure 6 shows the spring tabs of the mounting member engaging the arm portion of the eavestrough hook;
5 and

Figures 7 and 8 show a one-piece eavestrough hook.

DETAILED DESCRIPTION OF THE PREFERRED EMBODIMENTS

The eavestrough bracket assembly 2 includes an
10 elongate mounting member 4 having three ports 6 for receiving screw fasteners 8. The screw fasteners positively secure the mounting member to the fascia board 1.

An eavestrough hook 20 is adapted to be slidable on the elongate mounting member 4 to positively secure the
15 eavestrough hook in a perpendicular manner to the mounting member and to the fascia board. The back face 24 of the eavestrough hook has an undercut slot 22. Projecting into the slot 22 is the upper shoulder 26 and the lower shoulder 28. The mounting member 4, as shown in Figure 3, also has
20 upper shoulders 10 and lower shoulders 12 either side of the mounting projections 14. The mounting projections 14 serve to space the shoulders 10 and 12 off the face of the fascia board and provide room for receiving the upper and lower shoulders 26 and 28 of the eavestrough hook. With
25 this arrangement, the eavestrough hook 2 is slidable on the mounting member 4 and is retained in a center position on the mounting member by spring tabs 16.

The eavestrough hook has a top flange 30 which supports and stiffens the upper shoulder 26 and this upper
30 flange merges with the web 34 of the arm 32. At the bottom edge of the web 34 is the lower flange 36. The web and lower flange define an inverted "T" type structure and stiffen arm 32. The lower flange 36 is bowed upwardly and

is compressed under the high loads. At the distal end of the arm 32 is the front eavestrough engaging section 40 which cooperates with the rear eavestrough engaging section 42 to allow hanging of the eavestrough 60 from the front and rear upper edges. The eavestrough is slidable along these engaging sections.

Figure 5 illustrates the front face of the mounting member 4 and the spring tabs 16. The eavestrough hook is inserted on one end of the mounting member 4 and as it is moved along the mounting member, the first spring tab 16 is forced inwardly. This allows the back face of the eavestrough hook to clear the spring tab and allow it to eventually move outwardly to an overlapped position, as shown in Figure 6. Thus, the spring tabs 16 cooperate with section 39, as shown in Figure 6, of the arm 32 to positively locate the eavestrough hook on the mounting tab. It can be appreciated that the eavestrough hook can be removed by depressing one of the spring tabs 16 and sliding the eavestrough hook off of the mounting member.

As shown in Figure 1, the mounting members 4 may be secured to the fascia board at appropriate locations along the length of the fascia board and at an appropriate height below the shingles 3. The eavestrough hooks can be inserted on an eavestrough section and slide therealong to the appropriate position. The eavestrough section and hooks are then brought up to the fascia board where the mounting tabs have already been secured at the appropriate locations. The eavestrough hooks can then be secured to the fascia board 1 by sliding the eavestrough hooks onto the mounting members. Securement of two hooks will support the eavestrough section and the remaining hooks can then be secured. This provides a simple means for securing of the eavestrough section on the fascia board, which does not require tools after the mounting member has been secured.

The eavestrough hook 100 of Figures 7 and 8 is a single piece design having a thin profile back face 102.

THE EMBODIMENTS OF THE INVENTION IN WHICH AN EXCLUSIVE PROPERTY OR PRIVILEGE IS CLAIMED ARE DEFINED AS FOLLOWS:

1. An eavestrough bracket assembly comprising a mounting member to be secured to a fascia board, an eavestrough hook adapted to be supported from said mounting member in a perpendicular manner to one side thereof, said eavestrough hook including a back face having an undercut securing slot extending across said back face which slidably receives said mounting member and releasably secures said hook to said mounting member; said mounting member including securing shoulders which are received in and form an overlapped region with said undercut securing slot.
2. An eavestrough bracket assembly as claimed in claim 1 wherein said mounting member is elongate and said securing shoulders extend in the longitudinal direction of the mounting member.
3. An eavestrough securing bracket assembly as claimed in claim 2 wherein said mounting member includes at least one spring tab which cooperates with said eavestrough hook to locate and retain said hook on said mounting member.
4. An eavestrough securing bracket assembly as claimed in claim 3 wherein said mounting member has two spring tabs which locate said eavestrough hook between said spring tabs.
5. An eavestrough securing bracket assembly as claimed in claim 4 wherein said mounting member includes at least two ports spaced in the length of said mounting member which ports receive fasteners for securing said mounting member to a fascia board.
6. An eavestrough securing bracket assembly as claimed in claim 4 wherein said mounting member includes at least two ports spaced in the length of said mounting member which

ports receive fasteners for securing said mounting member to a fascia board.

7. An eavestrough securing bracket assembly as claimed in claim 3 wherein said mounting member is generally flush with the back face of said eavestrough hook when said mounting member is received in said eavestrough hook.

8. An eavestrough securing bracket assembly as claimed in claim 1 wherein said eavestrough hook includes an outwardly extending support arm, said support arm at a distal end thereof having a slot arrangement for engaging and supporting an eavestrough edge, said support arm adjacent said backface including a downwardly opening slot arrangement adapted to engage and suspend beneath said arm an edge portion of an eavestrough, and wherein said support arm is of an inverted "T" section and a lower edge of the arm has a curved profile between said back face and said distal end.

9. An eavestrough securing bracket assembly as claimed in claim 8 wherein said support arm includes reinforcing flanges projecting either side of said support arm and stiffening said eavestrough hook.

10. An eavestrough securing bracket assembly as claimed in claim 9 wherein said reinforcing flanges define a longitudinally curved surface.

11. An eavestrough securing bracket assembly as claimed in claim 8 wherein said support arm adjacent said under cut securing slot includes a reinforcing flange forming one surface of said securing slot and extending laterally across said support arm.

12. An eavestrough securing bracket assembly as claimed in claim 11 wherein said reinforcing flange includes at

least one notched region for releasably locking with said mounting member.

FIG. 1.

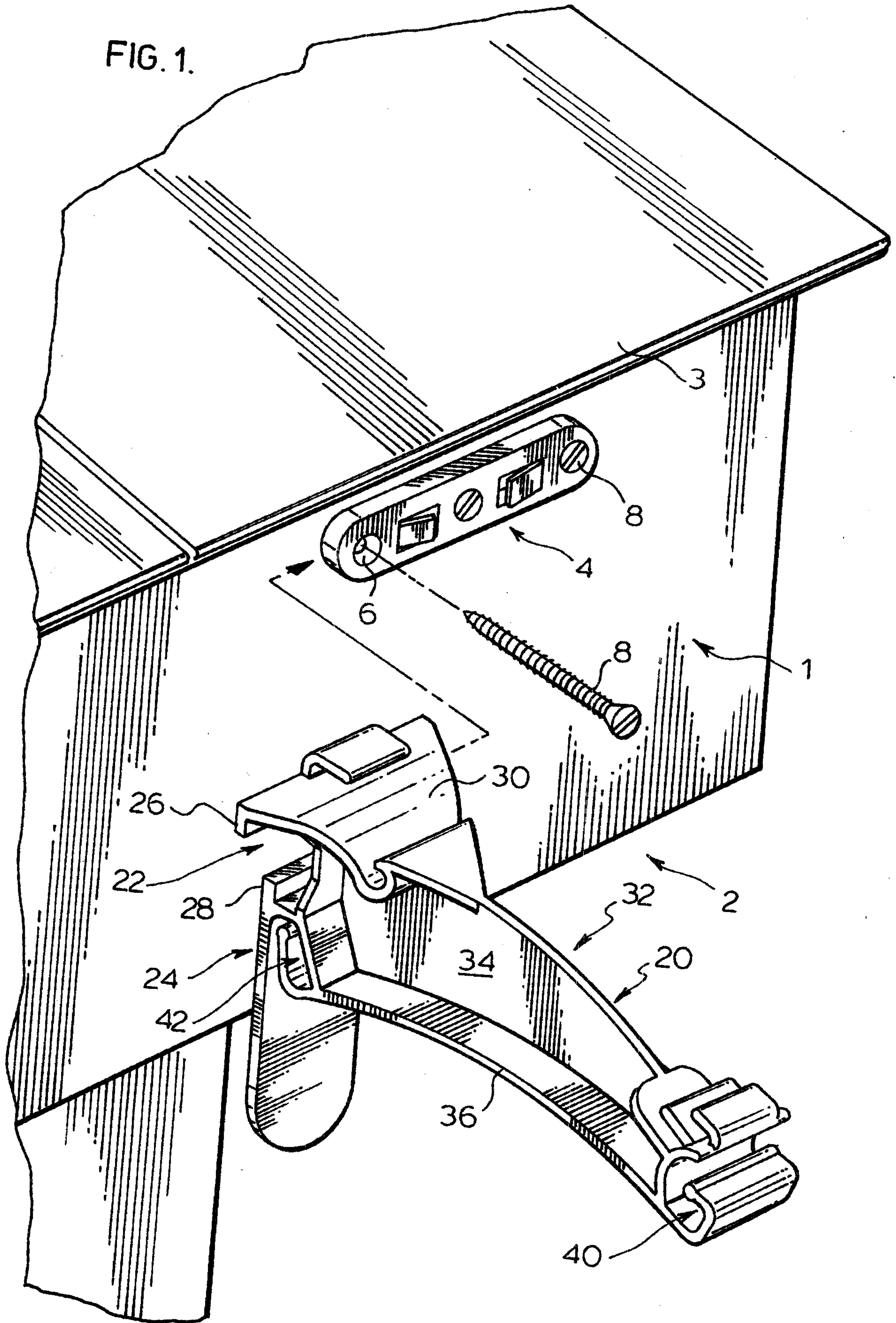

FIG. 2.

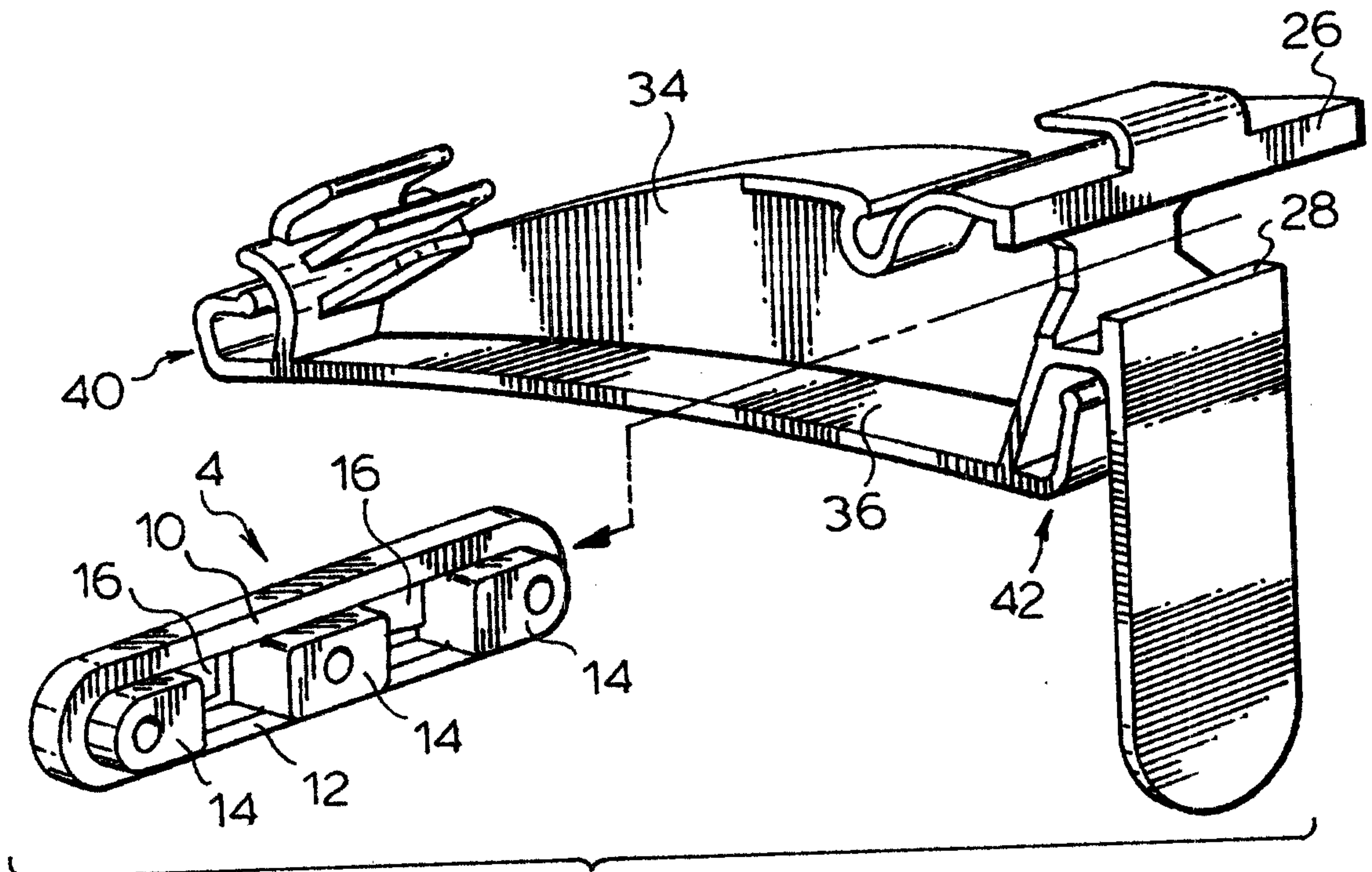
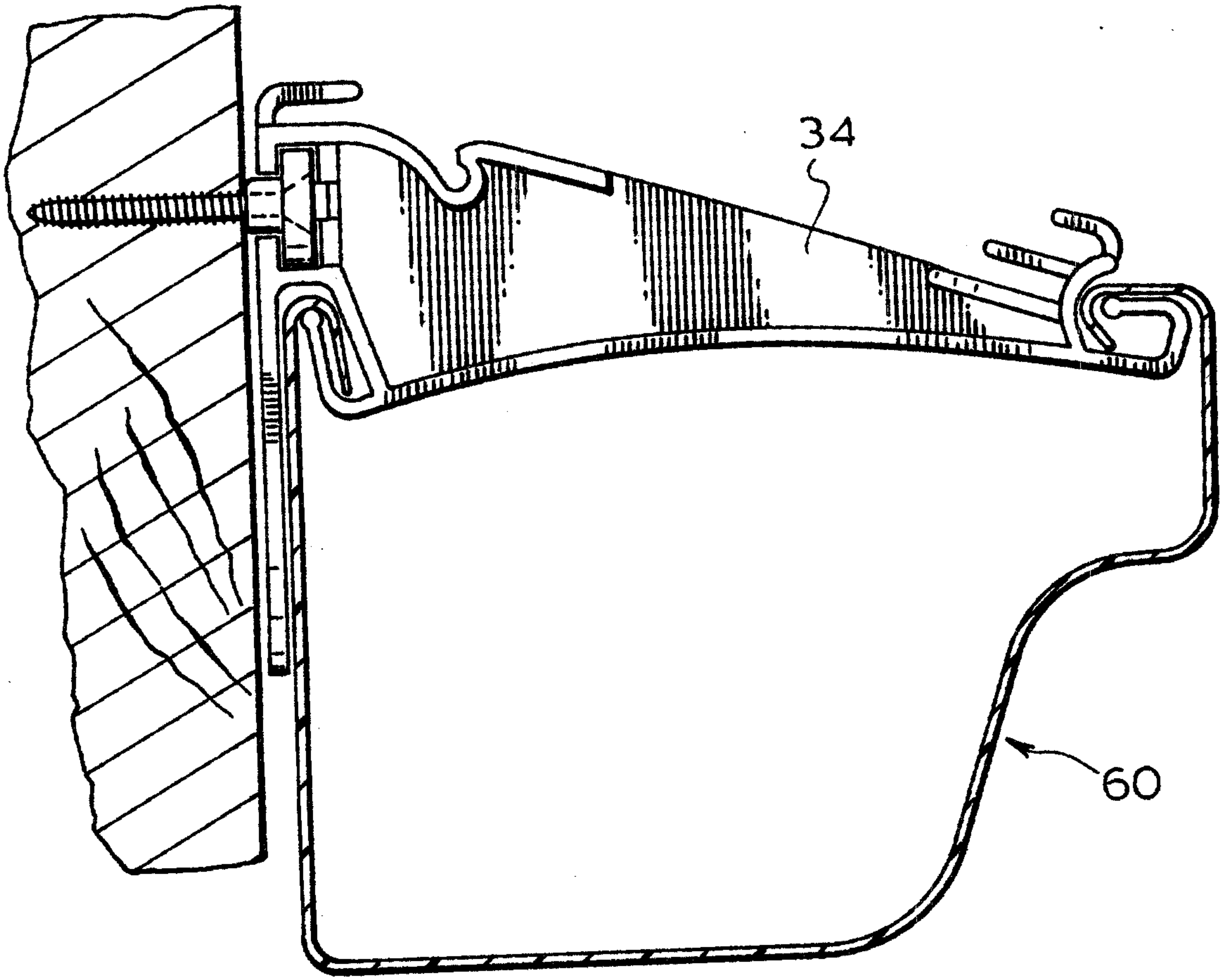

FIG. 3.

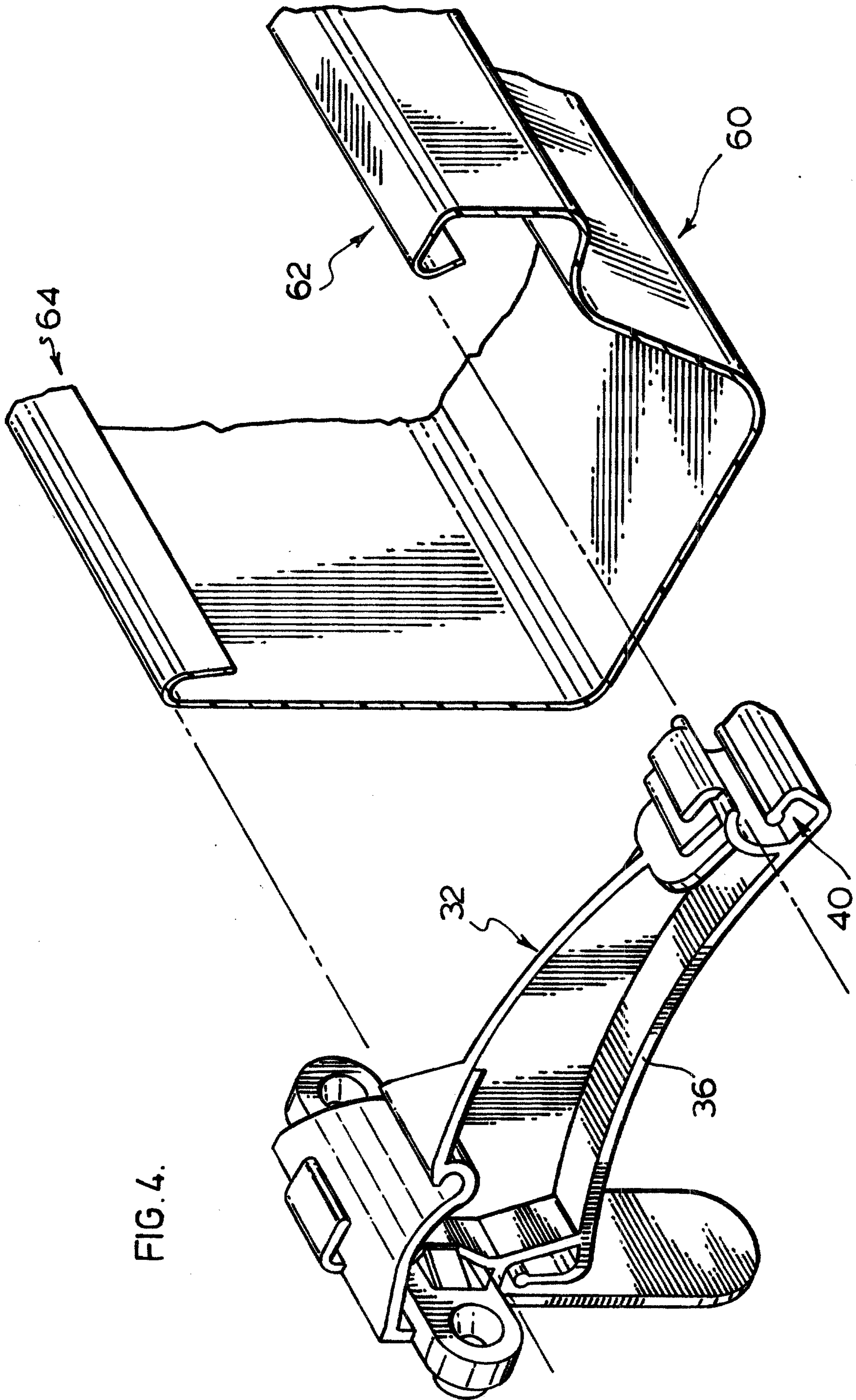

FIG. 4.

