



US00D913079S

(12) **United States Design Patent**
Patching

(10) **Patent No.:** **US D913,079 S**

(45) **Date of Patent:** **** Mar. 16, 2021**

(54) **FLEXIBLE SHEET FOR INSERTION IN A BOREHOLE**

3,330,361 A * 7/1967 McCullough E21B 43/082
166/227

4,182,414 A * 1/1980 Sanders E03B 3/12
166/74

(71) Applicant: **Total Blasthole Solutions Pty Ltd,**
Mount Pleasant (AU)

D279,352 S * 6/1985 Mitchell D8/354
(Continued)

(72) Inventor: **Gregory Patching,** Attadale (AU)

OTHER PUBLICATIONS

(73) Assignee: **Total Blasthole Solutions Pty Ltd,**
Mount Pleasant (AU)

Anonymous, *Benchsaver Specifications*, downloaded from the internet on Feb. 1, 2019 from <http://www.mtigroup.com.au/benchsaver.html>, MTI Group, Wangara, AU (Publ), (2 pages).

(**) Term: **15 Years**

(Continued)

(21) Appl. No.: **29/647,240**

Primary Examiner — Lauren R Calve

(22) Filed: **May 10, 2018**

(74) *Attorney, Agent, or Firm* — Perry + Currier Inc.;
Alan F. Feeney

(30) **Foreign Application Priority Data**

(57) **CLAIM**

The ornamental design for a flexible sheet for insertion in a borehole, as shown and described.

Nov. 10, 2017 (AU) 201716879

DESCRIPTION

(51) **LOC (13) Cl.** **08-05**

FIG. 1 is a perspective view of a flexible sheet for insertion in a borehole showing my new design in a flat state;

(52) **U.S. Cl.**

USPC **D8/354**; D15/21

FIG. 2 is a perspective view of the flexible sheet for insertion in a borehole of FIG. 1 shown in a curved state;

(58) **Field of Classification Search**

USPC D8/349, 354, 355; D15/21, 28

CPC E21B 43/103; E21B 43/108; E21B 43/086;

E21B 33/1277; E21B 43/08; E21B

47/024; E21B 43/084

See application file for complete search history.

FIG. 3 is a top view thereof;

FIG. 4 is a front view of the flexible sheet for insertion in a borehole of FIG. 1;

FIG. 5 is a rear view thereof;

FIG. 6 is a top view thereof;

FIG. 7 is a partial enlarged top view thereof according to broken line circle "7" shown in FIG. 6;

FIG. 8 is a side view of the flexible sheet for insertion in a borehole of FIG. 1; and,

FIG. 9 is a partial enlarged side view according to broken line circle "9" shown in FIG. 8.

The claim is shown with a symbolic break in its length. The appearance of any portion of the article between the break lines forms no part of the claimed design.

(56) **References Cited**

U.S. PATENT DOCUMENTS

1,380,182 A * 5/1921 Bigelow E21B 17/00
166/207

3,177,945 A * 4/1965 Fether B01D 29/33
166/227

3,275,081 A * 9/1966 Beylik E21B 43/086
166/228

1 Claim, 6 Drawing Sheets

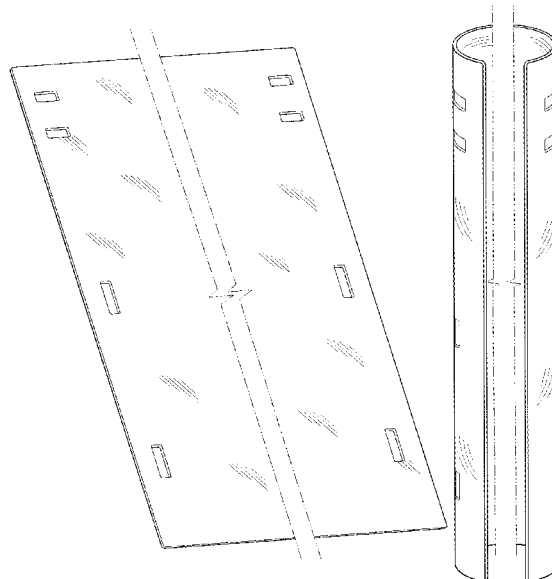

(56)

References Cited

U.S. PATENT DOCUMENTS

7,861,787 B2 * 1/2011 Russell E21B 43/25
166/310
D671,960 S * 12/2012 Kirk D15/21
8,800,650 B2 * 8/2014 Spray E21B 17/00
166/207
9,303,493 B2 * 4/2016 Hagen E21B 43/086
9,617,802 B2 * 4/2017 Lastra E21B 17/20
2001/0039711 A1 11/2001 Donnelly et al.
2009/0101363 A1 * 4/2009 Teixeira E21B 17/22
166/384
2013/0068478 A1 * 3/2013 Allen E21B 33/138
166/380

OTHER PUBLICATIONS

Anonymous, *Collar*, Blast Training International Glossary, downloaded from the internet on Feb. 14, 2019 from <http://online.blasttraining.com.au/mod/glossary/view.php?id=40&mode=&hook=all&sortkey=&sortorder=&fullsearch=0&page=-1>, Blast Management International, Manly, AU (Publ)(1 page).

Anonymous, *Ecocones*, downloaded from the internet on May 17, 2018 from <http://americanblasting.co/products/ecocones>, American Blasting Technology, Sour Lake, TX (Publ)(1 page).

* cited by examiner

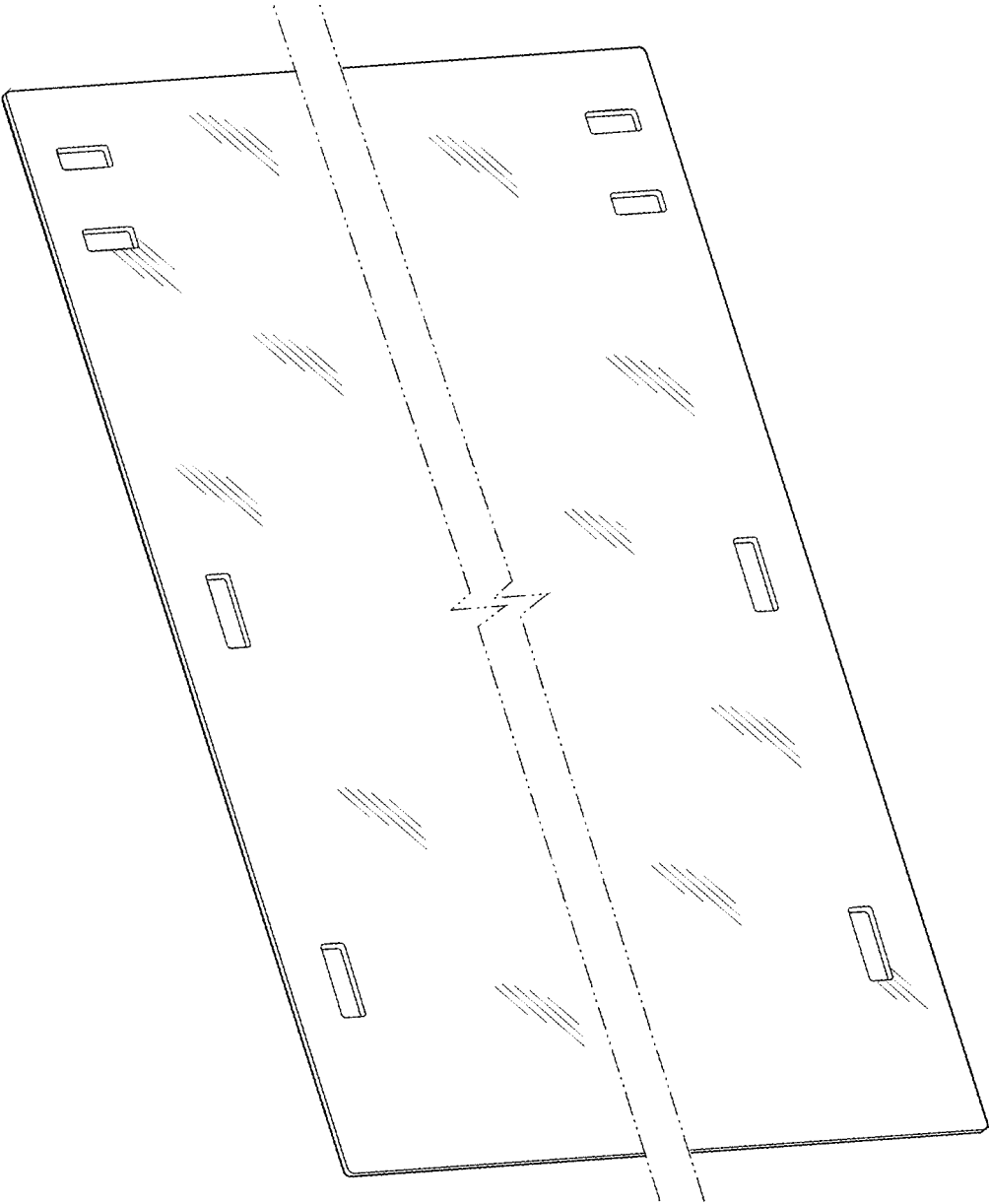

Fig. 1

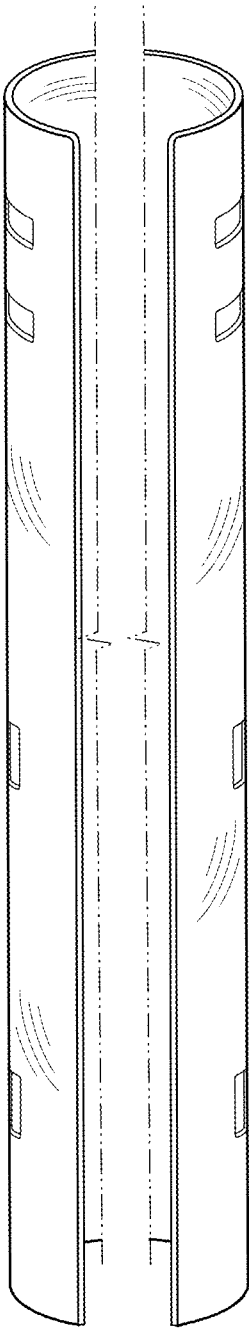

Fig. 2

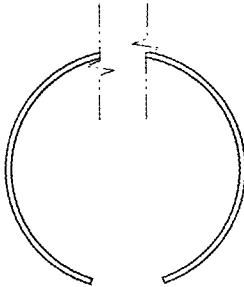

Fig. 3

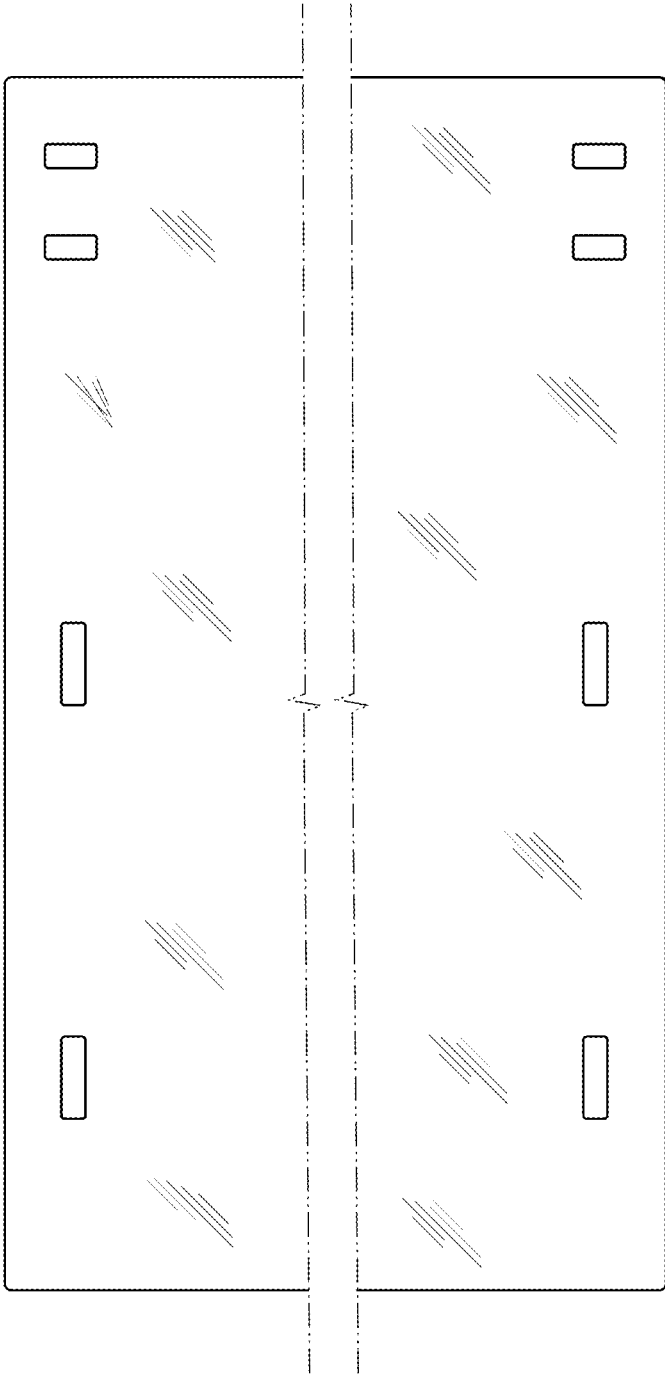

Fig. 4

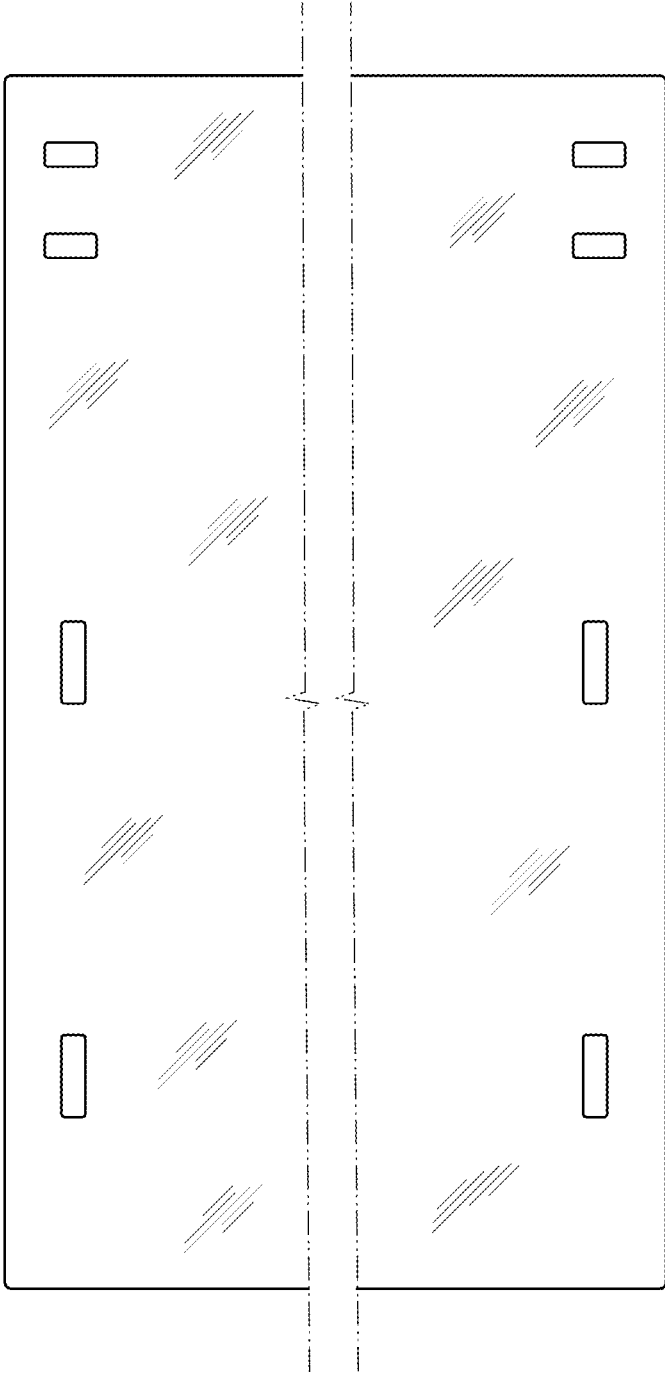

Fig. 5

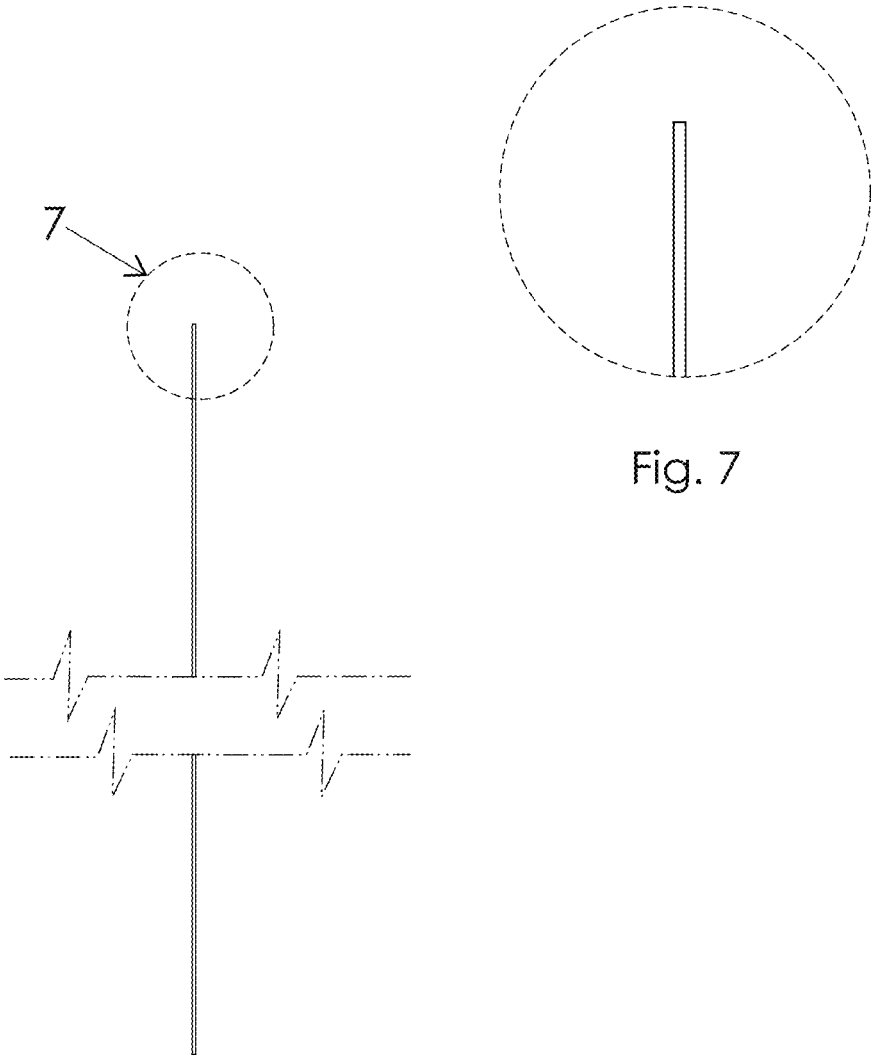

Fig. 7

Fig. 6

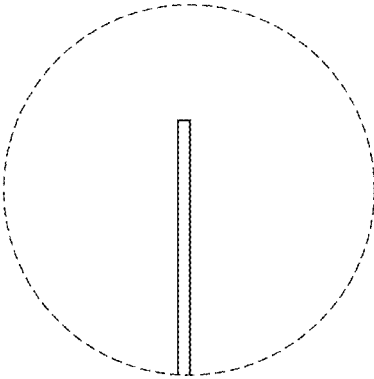

Fig. 9

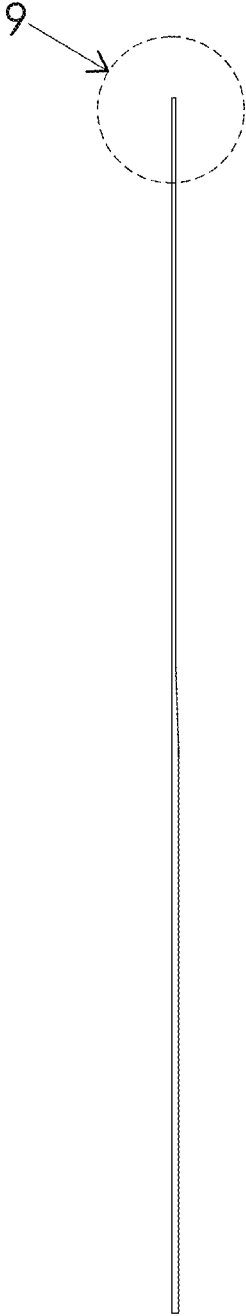

Fig. 8