

(No Model.)

J. O'BRIEN.  
TELEGRAPH INSULATOR.

No. 347,635.

Patented Aug. 17, 1886.

Fig. 3.

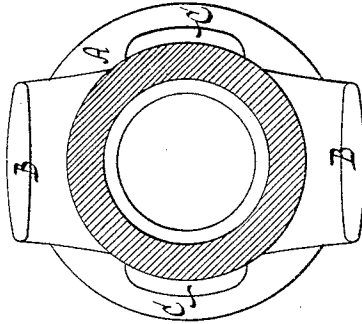

Fig. 2.

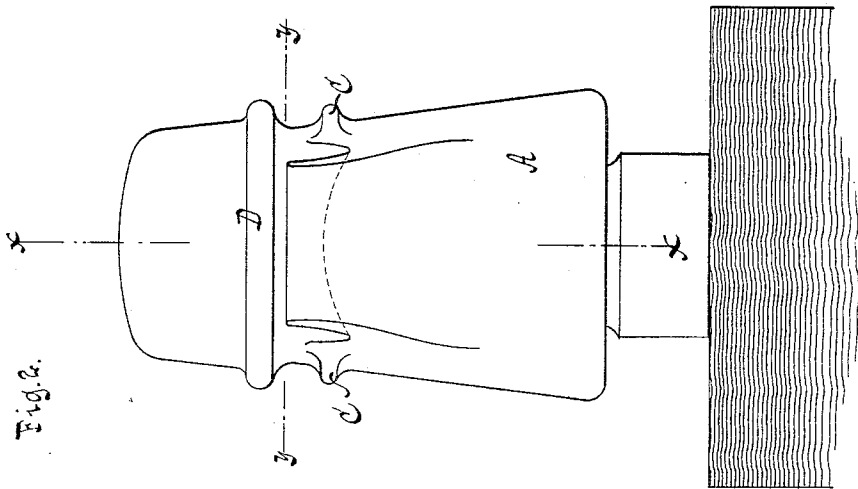
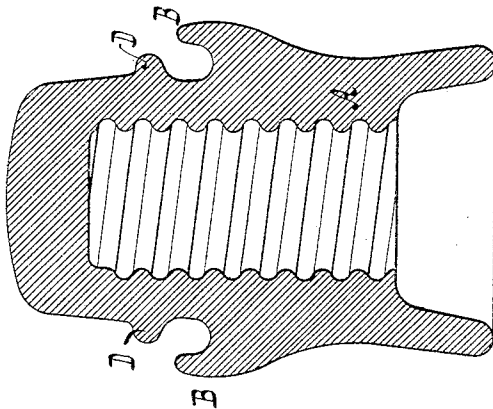

Fig. 1.



WITNESSES:

*Otto Aufelant*  
*William Miller*

INVENTOR  
**John O'Brien**  
BY  
*Van Sautwood & Hauff*  
his ATTORNEYS

# UNITED STATES PATENT OFFICE.

JOHN O'BRIEN, OF NEW YORK, N. Y., ASSIGNOR TO WILLIAM BROOKFIELD,  
OF SAME PLACE.

## TELEGRAPH-INSULATOR.

SPECIFICATION forming part of Letters Patent No. 347,635, dated August 17, 1886.

Application filed May 20, 1886. Serial No. 202,761. (No model.)

### *To all whom it may concern:*

Be it known that I, JOHN O'BRIEN, a citizen of the United States, residing at New York, in the county and State of New York, have invented new and useful Improvements in Telegraph-Insulators, of which the following is a specification.

This invention has for its object to provide a novel and efficient telegraph-insulator; and it consists in the features of construction hereinafter described and claimed, reference being made to the accompanying drawings, illustrating the invention, in which—

Figure 1 is a section in the plane  $xx$ , Fig. 2. Fig. 2 is a side elevation of my insulator. Fig. 3 is a horizontal section in the plane  $yy$ , Fig. 2.

Similar letters indicate corresponding parts.

In the drawings, the letter A designates the body of a telegraph-insulator, which is by preference made of glass, but which may be made of any other material suitable for the purpose. The insulator shown is provided with an internal screw-thread, for the purpose of securing the same in position on a telegraph-pole; but my invention is not restricted to screw-insulators, since it can be applied to insulators provided with other suitable means for securing the same in position on a telegraph-pole.

On opposite sides of the body A are formed two lugs, B, which serve to support the line-wire both while the same is being put up and also after the same is permanently in position. That part of the surface of the lugs on which the line-wire rests is made convex, so as to permit the same being drawn taut at a comparatively acute angle. When the wires are being placed in position over insulators provided with straight line-wire-supporting surfaces, the wires will kink or bend at the edge of these supports as they are being drawn taut, unless the line-man on the ground is a considerable distance from the insulator and draws the wire over the insulator at a very obtuse angle. To obviate this difficulty, I have formed the line-wire-supporting surface, as above described. The ad-

vantage of having two such supporting-surfaces, besides being a support for two wires, when necessary, is that in making sharp bends or a return-bend either lug of the insulator can be employed without turning the insulator, a very great advantage when the insulators are tightly fixed to the poles.

To support the "tie-wires" by which the line-wire is usually secured to the insulator, ridges C are formed on the body of the insulator, between the lugs B. These ridges serve to hold the tie-wire in place, particularly during the operation of drawing the line-wire taut. These ridges, together with the annular shoulder D, also forms a recess in which the tie-wires rest, and serve to hold the same in position on the insulators. A somewhat similar recess is formed between the lugs B and the shoulder D for retaining the line-wire.

By the construction above described, the advantages of the old form of insulator, having an annular recess for supporting the wire when in position, are retained, with the additional advantage of a support for the wire during the whole operation of "running" the wires, which is particularly necessary when the insulator is attached directly to a pole without the use of a cross-arm.

What I claim as new, and desire to secure by Letters Patent, is—

1. A telegraph-insulator provided with a line-wire lug, having a convex supporting-surface for said wire, substantially as described.

2. A telegraph-insulator provided with two line-wires, supporting-lugs arranged at opposite sides of its body, and each having a convex wire-supporting surface, substantially as and for the purposes described.

3. A telegraph-insulator having two opposite line-wire-supporting lugs, each having a convex wire-supporting surface, and provided intermediate of said lugs with two oppositely-arranged laterally-projecting tie-wire-supporting lugs, substantially in line with the convex surfaces of the line-wire-supporting lugs, substantially as described.

4. A telegraph-insulator provided with two  
line-wire-supporting lugs on opposite sides  
of its body, and with two oppositely-arranged  
and laterally-projecting tie-wire-supporting  
5 ridges between said lugs, substantially as de-  
scribed.

In testimony whereof I have hereunto set

my hand and seal in the presence of two sub-  
scribing witnesses.

JOHN O'BRIEN. [L. s.]

Witnesses:

W. HAUFF,

OTTO HUFELAUER.