

(19) World Intellectual Property Organization
International Bureau



(43) International Publication Date
30 April 2009 (30.04.2009)

PCT

(10) International Publication Number
WO 2009/055806 A1

(51) International Patent Classification:
A63D 15/08 (2006.01)

(21) International Application Number:
PCT/US2008/081354

(22) International Filing Date: 27 October 2008 (27.10.2008)

(25) Filing Language: English

(26) Publication Language: English

(30) Priority Data:
60/982,881 26 October 2007 (26.10.2007) US

(72) Inventors; and

(75) Inventors/Applicants (for US only): OWEN, Donald, W. [US/US]; 5410 Onset Bay Drive, Rowlett, TX 75089 (US). BUNNELL, Eldon, R. [US/US]; 5840 Baker Drive, The Colony, TX 75056 (US).

(74) Agent: ISIDORE, Eustace, P.; Dillon & Yudell LLP, 8911 N. Capital Of Texas Hwy., Suite 2110, Austin, TX 78759 (US).

(81) Designated States (unless otherwise indicated, for every kind of national protection available): AE, AG, AL, AM, AO, AT, AU, AZ, BA, BB, BG, BH, BR, BW, BY, BZ, CA, CH, CN, CO, CR, CU, CZ, DE, DK, DM, DO, DZ, EC, EE, EG, ES, FI, GB, GD, GE, GH, GM, GT, HN, HR, HU, ID, IL, IN, IS, JP, KE, KG, KM, KN, KP, KR, KZ, LA, LC, LK, LR, LS, LT, LU, LY, MA, MD, ME, MG, MK, MN, MW, MX, MY, MZ, NA, NG, NI, NO, NZ, OM, PG, PH, PL, PT, RO, RS, RU, SC, SD, SE, SG, SK, SL, SM, ST, SV, SY, TJ, TM, TN, TR, TT, TZ, UA, UG, US, UZ, VC, VN, ZA, ZM, ZW.

(84) Designated States (unless otherwise indicated, for every kind of regional protection available): ARIPO (BW, GH, GM, KE, LS, MW, MZ, NA, SD, SL, SZ, TZ, UG, ZM, ZW), Eurasian (AM, AZ, BY, KG, KZ, MD, RU, TJ, TM), European (AT, BE, BG, CH, CY, CZ, DE, DK, EE, ES, FI, FR, GB, GR, HR, HU, IE, IS, IT, LT, LU, LV, MC, MT, NL, NO, PL, PT, RO, SE, SI, SK, TR), OAPI (BF, BJ, CF, CG, CI, CM, GA, GN, GQ, GW, ML, MR, NE, SN, TD, TG).

Published:
— with international search report



WO 2009/055806 A1

(54) Title: CUE STICK, CUE STICK HANDLE WITH RIGID FOREARM AND METHOD OF MAKING THE SAME

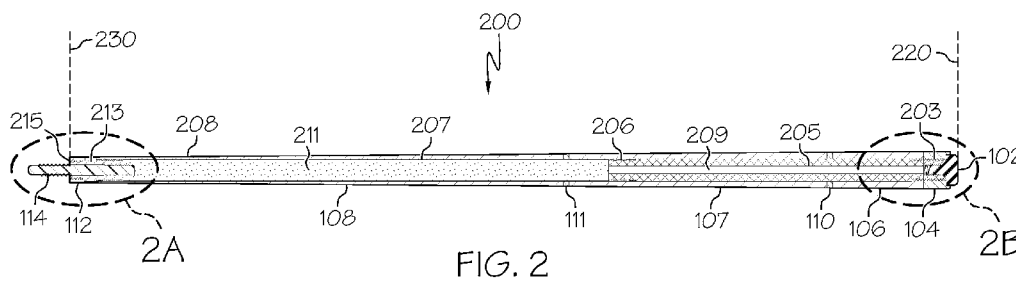

(57) Abstract: A cue stick handle includes: an exterior casing of conical members; a rigid inner core, which includes linearly interlocked and glued components, including (a) a rigid tube composed of a hard, tensile material that provides steel-like characteristics, including rigidity and stiffness and (b) a pin holder composed of a strong composite or plastic material, having a high tensile and high bending strength, and adhesively coupled to the tube. The tube is filled with a vibration-dampening, foam-like material. The rigid inner core may include a wood core securely mated to an end of the rigid tube. A pair of collars is coupled to each end of the rigid inner core to secure the rigid inner core inside the exterior casing.

CUE STICK AND CUE STICK HANDLE WITH RIGID FOREARM AND METHOD OF MAKING THE SAME

PRIORITY CLAIM

[0001] The present application claims benefit of U.S. Provisional Patent Application Ser. No. 60/982,881, filed October 26, 2007, titled "Cue Stick, Cue Stick Handle And Method Of Making The Same; U.S. Patent Application Ser. No. 12/258,986, filed October 27, 2008, titled "Cue Stick, Cue Stick Handle with Rigid Forearm and Method of Making the Same;" and U.S. Patent Application Ser. No. 12/259,047, filed October 27, 2008, titled "Cue Stick, Cue Stick Handle with Rigid Inner Core and Method of Making the Same;" the contents of which are incorporated herein by referenced in their entirety.

BACKGROUND OF THE INVENTION

1. Field of the Invention

[0002] The illustrative embodiment of the present invention relates generally to cue sticks and specifically to an improved cue stick, cue stick handle and design thereof.

2. Description of the Related Art

[0003] A cue stick for playing pool or billiards or similar games in that genre is an elongated tapered shaft with a handle at one end and a tip at the other end. The cue stick can be integrally formed or made of two or more members engaged together along a linear axis. For example, the cue stick may be made of a cue shaft portion, complete with a tip for striking the balls, and a base or handle portion to provide the length and balance to the shaft portion. The two portions are secured at a joint, which allows the user to separate the two portions for ease in carrying and storing the cue stick. Typically, joints are bolt-type couplings with a screw mechanism (or pin), allowing the handle to be readily engaged and disengaged from the cue shaft.

[0004] One common fault observed in this existing design is the weakness of the joint at which the cue shaft connects to the handle. With conventional two or three piece cue sticks, the joint connecting the shaft to the handle are typically weak and are prone to breaking or splitting when exposed to lateral or bending stress.

[0005] In order to provide optimum performance, a cue stick needs to have a rigid handle section and have a preferably perfectly straight axis. It is also desirable for the cue stick to generate minimal vibration when striking a cue ball, and to provide a radially consistent “feel” and performance regardless of the orientation or rotation of the cue stick in the player’s hand. However, another fault common to most conventional cue sticks is the lack of sufficient rigidity in the handle between the cue shaft and the point at which the player holds the handle. This lack of rigidity occurs because, generally, most professional grade cue sticks and/or cue handles are made of hardwood, such as hard maple, which tends to be less rigid than would be optimal for the cue handle.

[0006] Most design improvements in cue sticks have focused on improving the cue shaft, since it is the shaft that strikes the balls and needs to exhibit certain bend and response characteristics when the ball is struck. Consequently, most cue shafts are light weight and have a certain amount of flexion at the tip end in order to provide for better playability on the cue ball.

[0007] However, several of the performance characteristics of importance to a cue stick, e.g., weight and balance (or center of gravity) and rigidity, are determined by the handle. These characteristics also add to the good “feel” of a cue stick. Given the desire for a lighter cue shaft, characteristics of weight and balance and rigidity are primarily addressed in the cue handle. Several designs exist that enable a user to add weight to the cue stick after the stick is manufactured. For example, U. S. Patent Application 2002/0072423 provides a cue stick with a “weight slot” in the handle segment in which removable weights may be added to adjust the overall weight of the stick. Still other methods exist, such as sliding and/or attaching weight rings on to the outer circumference of the handle, to enable addition of a desired weight to the cue stick. Changes to the weight, balance, flex and overall operational characteristics of a cue stick are conventionally accomplished by insertion of weights, stiffening members such as inlays or spliced-in “points” in the forearm, and spacer material.

[0008] While these prior art methods enable the addition of weight to the cue stick, the weight is typically added in a manner that results in a weight distribution and a center of mass that are less desirable. Additionally, the single focus on adding weight to the stick requires a post-

manufacture “fix” or enhancement of the cue stick to attempt to slightly improve the overall playability of the cue stick.

BRIEF DESCRIPTION OF THE DRAWINGS

[0009] This invention is described with illustrative embodiments in the following specification with reference to the drawings, in which like numbers represent the same or similar elements, as follows:

[0010] **FIG. 1** is an external/perspective view of an example cue handle, designed according to embodiments of the invention;

[0011] **FIGs. 2, 2a and 2b** are cross sectional views illustrating the component makeup of a first-type cue handle with connected, inner core members including a rigid segment and specific sections of the first-type cue handle, in accordance with one embodiment of the invention;

[0012] **FIGs. 3, 3a, 3b and 3c** are cross sectional views illustrating the component makeup of a second-type cue handle with a rigid inner core and specific sections of the second-type cue handle, in accordance with one embodiment of the invention;

[0013] **FIG. 4A** is a sectional view of the outer casing of the cue handle according to one embodiment of the invention;

[0014] **FIG. 4B** is a sectional view of a two-member, connected, rigid inner core of the cue handle, according to one embodiment of the present invention;

[0015] **FIG. 5** illustrates an example cue stick complete with the cue handle of **FIGs. 1 and 2 or 3**, which has been attached to a cue shaft via a joint pin (screw) affixed to a pin holder with high tensile strength, in accordance with one embodiment of the invention; and

[0016] FIG. 6 is a sectional view of the rigid inner tube of the cue handle's inner core with multiple perforations (holes) to reduce density and/or weight within sections of the cue handle, in accordance with one embodiment of the invention.

DETAILED DESCRIPTION OF ILLUSTRATIVE EMBODIMENTS

[0017] The illustrative embodiments provide a method, system and cue handle design that provides optimal weight and balance to the cue stick, including effective mass distribution for an optimal center of mass, while ensuring other desired qualities, including: a high level of rigidity in the forearm; increased strength in the joint that connects the cue handle to the cue shaft to prevent or substantially eliminated/reduce breakage at the joint; vibration-dampening within the handle itself; predictable weight and center of gravity; and ease of assembly during manufacture. These and other beneficial properties are associated with the cue handle and cue stick described herein.

[0018] In the following detailed description of exemplary embodiments of the invention, specific exemplary embodiments in which the invention may be practiced are described in sufficient detail to enable those skilled in the art to practice the invention, and it is to be understood that other embodiments may be utilized and that architectural, mechanical, and other changes may be made without departing from the spirit or scope of the present invention. The following detailed description is, therefore, not to be taken in a limiting sense, and the scope of the present invention is defined only by the appended claims.

[0019] Within the descriptions of the figures, similar elements are provided similar names and reference numerals as those of the previous figure(s). Where a later figure utilizes the element in a different context or with different functionality, the element is provided a different leading numeral representative of the figure number (e.g, 1xx for Figure 1 and 2xx for Figure 2). The specific numerals assigned to the elements are provided solely to aid in the description and not meant to imply any limitations (structural or functional) on the invention.

[0020] It is understood that the use of specific component, material, device and/or parameter names are for example only and not meant to imply any limitations on the invention. The

invention may thus be implemented with different nomenclature/terminology utilized to describe the components/material/devices/parameters herein, without limitation. Each term utilized herein is to be given its broadest interpretation given the context in which that terms is utilized.

[0021] Several descriptive terms are utilized to describe certain functional characteristics of cue sticks. To facilitate the understanding of the described embodiments of the present invention described below, the following terminology will be used as described below.

(a) Weight: describes the overall weight, as measured in grams (SI units) or ounces (English/American units) of a cue stick, and specifically the cue handle;

(b) Balance: describes the location of the center of gravity of a cue stick along its length, or the weight distribution of a cue stick along its length; according to the design features of the cue handle, balance also accounts for effective mass distribution for an optimal effective center of mass of the completed cue stick when the cue handle is attached to a cue shaft; and

(c) Rigidity: describes the amount of stiffness along the longitudinal axis of the cue stick, and specifically the cue handle. This quality measures the amount of load required to be applied perpendicular to the longitudinal axis to cause the cue handle to bend/flex. A rigid cue stick is said to have little flex;

(d) Strength: describes the level of force required that can be resisted before a connecting joint between the cue shaft and cue handle breaks, when the cue stick is subjected to lateral (bending) force. Strength applies primarily to the joint structure at which the cue handle attaches to the cue shaft when assembled.

[0022] Additionally, in describing the cue stick handle, relative locations of components are described in terms of a first end at which the joint screw/pin is attached and a second end at which the rubber bumper may be inserted. For clarification, several other terms may also utilized interchangeably with the first end and second end, respectively, as follows: (a) first end, joint pin end, and anterior end all referencing the same general location of the cue handle; and (b) second end, bumper end, and posterior end referencing the same general location of the cue handle. The second or posterior end typically has a larger circumference than the first or anterior end, due to tapering of the cue handle's exterior casing. The first end and second end are

described as opposed to each other, meaning that along the longitudinal direction of the cue handle, one end is located at the opposite terminating point/end of the length of the cue handle, pointing in a first direction, relative to the other end, which is located at the next terminating point/end pointing in a second opposite direction. Also, the forearm section of the cue handle is defined as the location along the cue handle, closer to the first/anterior (joint) end. Specifically, the forearm is the portion of the length of the cue stick handle extending from approximately the joint (pin holder) toward the cue butt, up to the grip hand section (i.e., the location at which the cue handle is typically gripped by a user of the cue stick). The length of the forearm can vary roughly from 40% of the handle length up to 60%, and a substantial portion of the forearm is reinforced with a rigid inner core, according to the described embodiments. However, in alternate embodiments, a different length of the cue handle may be considered the forearm in some cue handle constructions and/or a different length of the cue handle may be provided with a rigid inner core, regardless of the definition of the forearm in such cue handle construction.

[0023] Additionally, as utilized herein and in the appended claims, the term “wood” is defined to include naturally fibrous materials such as, but not limited to, hardwoods and bamboo, as well as synthetic fibrous materials having properties similar to wood. Also, the usage of the term “rigid inner core” by itself describes that portion of the complete inner core that is comprised of one single member or of two or more adjoining members, where at least one member exhibits high-rigidity characteristics, similar to steel. The rigid member(s) of the inner core terminate at opposed ends of the cue handle with some mechanism/component (e.g., a joint pin holder and/or a weight-and-balance pin holder) for enabling connectivity to other components at the joint pin end and bumper end of the cue handle. The assembly that includes the connecting mechanism is referred to as a “complete inner core” or “inner core” (see **FIG. 4B** and description thereof below). Thus, references to “complete inner core” or “inner core” herein generally references the entire section of the cue handle that extends internal to the external casing, including the connecting mechanisms at the end. It is therefore appreciated that the cue handle designs provided by the various embodiments described herein includes an inner core or complete inner core that comprises multiple different components extending from the joint pin to the butt of the cue handle, with each component exhibiting varying functional characteristics along the length of the cue handle. Finally, the term “conical” when utilized to describe the cue handle and

portions/segments of the cue handle generally refers to a frustum with a circular base at the butt end of the shaft and tapered circular outer surface area that extends to the joint pin.

[0024] With reference now to the figures, **FIG. 1** illustrates a perspective (external) view of one embodiment of a cue stick handle (cue handle), designed according to the methods described herein, and as illustrate in the accompanying figures. As shown, cue handle **100** comprises a visible exterior casing (referred to as a casing because the shown exterior structure houses/surrounds internal components, as described below with reference to **FIG. 2**), having a first/posterior end **120** (right hand side of figure, also referred to as the bumper end or posterior end) and a second/anterior end **130** (left hand side of figure, also referred to as the joint screw end or anterior end) laterally disposed from the first end, and forming a rigid conical structure or circular frustum (see **FIG. 4A**). The exterior view of cue handle **100** has the appearance of a solid structure comprised of three adjoining segments **106**, **107**, **108** of different lengths. The adjoining segments are constructed of at least a first “wood-type” material, such as wood, wood fiber, wood veneer, or synthetic wood, for example, to provide the look and feel of wood. The segments **106**, **107**, **108** extend along the longitudinal axis of the cue handle **100**, and are separated at the two connection points by spacers (or rings) **110**, **111** made of a different material (or different colored material). Notably, while three segments adjoined with two spaces are illustrated, the number of segments (and corresponding numbers of adjoining spacers) is variable, and can range from a single segment to another larger number of segments, e.g., 2, 4, 5, and so on.

[0025] The combination of the above materials in the manner described provides an external appearance of a cue handle **100** that is constructed of solid wood, separated by decorative spacers. As described above, the external casing could also be constructed from a single piece of wood without decorative rings or from multiple pieces/segments of wood. Thus, description of the casing as having three segments with two rings interspaced at the segment’s connecting points is provided solely for illustration, and the number of segments (from one to any finite number) and rings (from zero to another finite number) are only relevant to the design/manufacture of the cue handle, with respect to enabling accurate calculation of the weight attributable to the components of the exterior casing components, as well as a determination of

the resultant cue stick's center of gravity and effective mass distribution and center of mass when the exterior casing is placed around an interior core structure to form the cue handle.

[0026] Turning now to **FIG. 4A**, there is illustrated an example design of the three tapered conical segments (i.e., hollow, circular frustums) that make up the external casing of cue handle **100**. As shown, each segment **106, 107, 108** is actually a tapered cylinder, with all segments **106, 107, 108** having a consistent bore diameter (**D**). That is, the cylindrical hole extending through each of the three segments **106, 107, 108** has substantially the same inner diameter (**D**) and circumference. Notably, the outer circumference of segments **106, 107, 108** is tapered, such that when the segments **106, 107, 108** are aligned next to each other, they provide a consistent tapering of the outer circumference across the three segments **106, 107, 108**, while the internal diameter remains consistent. As noted above, the number of segments may range from one to a much larger number, and the description herein of three segments is solely for illustration.

[0027] As further illustrated by **FIG. 4A**, two small spaces x_1, x_2 , interrupt the consistency of the tapered outer edges. These spaces represent the width of the areas along the external casing of cue handle **100** in which the spacers **110, 111** (**FIG. 1**) are placed between the segments **106, 107, 108**. These spacers, which are not shown in this depiction, also have an inner diameter that is substantially the same as the diameter of the three segments **106, 107, 108**. Further, the spacers **110, 111** also have a somewhat tapered exterior surface to enable consistent line of tapering between each connection point between the segments.

[0028] Two different designs of cue handles are provided by the described embodiments, based primarily on the type and/or construction of the inner core section of the cue handle. Generally, the embodiments are directed to either a first-type cue handle or a second type cue handle, which relates to a corresponding first-type inner core construction and a second-type inner core construction. The below description is thus separated into two main sections, Section A, which describes the first-type cue handle and Section B, which describes the second-type cue handle. The method steps described below are primarily directed to the second-type inner core construction.

[0029] As introduced above, the embodiments generally provide a cue stick handle having a longitudinal length extending from a joint screw end to a butt end, where the cue stick handle comprises: a hollow exterior casing comprising one or more rigid, conical members extending along a substantial portion of the longitudinal length; and an inner core that includes a rigid inner core (segment) confined within the hollow exterior casing for a first length between the joint screw end and the butt end. The rigid inner core has certain structural characteristics, including a rigidity that is similar to steel. With these characteristics exhibited by the rigid inner core, the cue handle itself exhibits similar structural characteristics in at least a forearm section of the cue handle. Additional characteristics, such as weight and balance (center of gravity), mass distribution to provide an optimal effective center of mass, as well as joint strength, of the various embodiments of the cue handle are controlled, based on the design of the cue handle and particularly the complete inner core.

A) FIRST-TYPE CUE HANDLE (TWO-MEMBER RIGID CORE CONSTRUCTION)

[0030] In the first embodiment, which is illustrated by **FIG. 2** (including **FIGs. 2A** and **2B**), the two member rigid inner core comprises a rigid metal core insertably coupled to a wood core. Thus, as generally illustrated by **FIG. 2**, described below, the rigid inner core is a first section of a longer inner core (or complete inner core) that includes two or more linearly interlocked and glued components providing a first threaded end and a second threaded end opposed to the first threaded end. The rigid inner core comprises a metal tube composed of a hard, tensile material that provides steel-like characteristics including rigidity/stiffness. The second portion/segment of the rigid inner core is a wood core, which is securely joined at a first end to the metal tube and has a second posterior end corresponding to the second end of the inner core.

[0031] Turning now to **FIG. 2**, which illustrates a cross sectional view of first-type cue handle **100**. **FIG. 2** is described with reference to **FIG. 1** (introduced above), as well as with specific reference to **FIG. 4B**, which illustrates the complete inner core construction of the first-type cue handle. Components representing external casing of first-type cue handle **200** are represented by the same reference numerals as **FIG. 1** (i.e., reference numerals in the 100 range), while components internal to the casing (primarily inner core components) are represented by reference numerals in the 200 range. As shown, first-type cue handle **200** comprises various components

of external casing as well as two adjoining segments making up the rigid inner core, which is coupled to different components at both ends of the cue handle. The combination of the two segment rigid inner core and the components coupled to their respective ends is collectively referred to herein as a complete inner core (see complete inner core **400** of **FIG. 4B**). **FIGs. 2A** and **2B** illustrated expanded views of sections of cue handle **200** at which the mating (i.e., joining or connecting) of components occur, at the first/posterior end **220** and second/anterior end **230**, respectively.

[0032] As with the descriptions of **FIGs. 1** and **4A** above, the illustrated external casing comprises three longitudinal, conical sections **106**, **107**, **108**, separated from each other by spacers **110**, **111**, for decorative and/or aesthetic purposes. The arrangement of the conical sections and spacers creates an external casing with a hollow, cylindrical, inside surface extending through most of the length of the cue handle **200**. The external casing fits around the complete inner core **400** and is securely glued in place over portions of the complete inner core **400**, and attached proximate to the ends of the complete inner core **400** via the first and second collars **104**, **112**, such that the rigid members of the complete inner core **400** are not exposed or visible.

[0033] Within the description of **FIG. 2**, the segments of external casing are assumed to be wood. Thus, the external casing comprises one or more pieces of tapered, conically shaped wood, having an internal diameter (D) that is marginally larger than the outer diameter ($D-d$) of the complete inner core **400**. With this small delta in the complete inner core's outer diameter, a near fit occurs when the external casing is placed over the complete inner core **400** and/or when the complete inner core **400** is placed within the external casing. In one embodiment, the external casing also comprises one or more plastic or composite spacers/rings **110**, **111** separating the individual pieces of tapered, cylindrically shaped wood, such that the continuity of the exterior wood on the cue handle **100** is broken.

[0034] When the individual components of the external casing are assembled together, they create an external shaft having a longitudinal cavity disposed between the first end **220** and the second end **230**, through which the complete inner core **400** extends. The length of the

longitudinal cavity may vary, depending on certain desired characteristics (such as overall weight, balance, and feel) of the cue handle (or cue stick assembled with the cue handle and a cue shaft). With this consideration of desired characteristics, the length and type of the various materials used for each component is factored into the design analysis, as described further below.

[0035] Returning now to **FIG. 1**, the first end **120** of the cue handle **100** includes a first collar **104**, fixedly attached to the end of the first segment **106** away from the point of connection with the first spacer/ring **110** and/or the second segment **107**. The first collar **104** is made of a third material, which may be similar to the second material. A resilient bumper **102**, made of rubber, plastic or composite material is removably inserted into a (threaded) hole within the first end **120** of the cue handle **100**. The bumper **102** is inserted flush against the edge of the first collar **104**, which edge is opposite the second edge of the first collar **104**, which is glued to the first segment **106**.

[0036] A second collar **112** is affixed at the anterior end of the third segment **108**, furthest away from the point of contact with the second spacer/ring **111** and/or the second segment **107**. The second collar **112** may be made from the third material, which may again be similar to (or the same as the second material). Protruding from the second end **130** of the cue handle **100** is a metal pin or screw, with connecting means for inserting the tip of the pin into a receptacle or hole, such as exists at the mating end of a cue shaft (see **FIG. 5**). The metal pin (**114**) shall hereinafter be referred to as joint pin **114** (or joint screw **114**) and represents the mechanism by which cue handle **100** attaches to a cue shaft.

[0037] As introduced above and illustrated by **FIGs. 2** and **4**, cue handle **200** comprises complete inner core **400**, having a plurality of linearly interlocked/connected components. According to the illustrative embodiment, each component is made of a different material, specifically selected to provide certain desired functional qualities in the cue handle **200**. Complete inner core **400** has a first/posterior end (**220**) and a second/anterior end (**230**), opposed to the first end (**220**). Complete inner core **400** also has a joint pin **114** extending externally from/through the second end (**230**).

[0038] Extending from the first end (220) to a first connecting joint 206 is wood core segment 205, made of wood or other material exhibiting similar performance characteristics. Wood core segment 205 may be solid or hollow. At the end proximate to the first end 220 of cue handle 200, wood core segment 205 is coupled to a first collar 104 via a coupling mechanism, such as a first-type threading surface (e.g., male threads), rotatably mated to a second-type threading surface (e.g., female thread).

[0039] FIG. 2B provides an expanded view of the connectivity of the various components at the first end 230 of cue handle 100. At the first end (106) of the external casing, corresponding to the first end 230 of the complete inner core 400, first collar 104, made of plastic, metal, wood, or other material, is affixed to the wood core segment 205. The first collar 104 is substantially cylindrical with an inner cylindrical space provided through the first collar 104 of relative dimensions to fit over the end of the wood core segment 205.

[0040] The wood core segment 205 is joined and/or affixed (e.g., threaded and glued) at the first joint 206 to a hollow rod/tube made of a hard, tensile material. In the described embodiment, the rod/tube (207) is made from a metal, such as steel, or other metallic substance exhibiting characteristics similar to steel, or other rigid/stiff metal. For simplicity, the rod/tube is referred to herein as a metal tube 207. Metal tube 207 has a first end, which is adhesively coupled/attached to wood core segment 205 at first joint 206.

[0041] Use of this tube in the manner illustrated and described provides a level of stiffness extending from the second joint to the point at which a user holds the cue handle. The level of stiffness is on the order of four times the relative stiffness of a conventional wooden handle, with a wood core. In yet another embodiment, a carbon fiber composite is utilized in place of the metal tube. The metal tube 207 has a length Y, which according to the illustrative embodiments, is less than the full length of the inner core 400.

[0042] At the second end of the metal tube 207, disposed longitudinally from the first joint 206 and corresponding to the second end 230 of cue handle 200, metal tube 207 is coupled at a second joint 208 to a very strong fiber glass epoxy material (i.e., a strong composite material) via

a coupling means (e.g., use of a strong bonding agent placed on one or more connecting surfaces). **FIG. 2A** provides an expanded view of the connectivity of the various components at the first/anterior end **230** of cue handle **200**. The epoxy material is referred to herein as pin holder **213**, and serves as an attachment to the metal tube **207** within which a first end of joint pin **114** is inserted. Pin holder **213** is made up of a material that has a high tensile and bending strength. In one embodiment, the modulus of elasticity of pin holder **213** is on the range of one third that of steel. Pin holder **213** provides a solid center joint, with strength substantially higher than that of wood, and approaching the strength of steel but without being as heavy as steel. Thus, unlike the conventional joints with single metal bolts to enable the coupling of the handle to the shaft, use herein of the pin holder **213** provides enhanced strength at the joint.

[0043] Pin holder **213** also provides an extended end (opposed to the end couple to the metal tube) to which second collar **112** may be coupled. An exposed end of the joint pin **114** protrudes from pin holder **213** of complete inner core **400**. The exposed end of joint pin **114** provides a joint screw at which a cue shaft may be readily engaged and disengaged (or permanently affixed – with adhesives) from/to the cue handle **200**, and vice versa.

[0044] In one embodiment, the metal tube **207** includes therein a (pliable) filling substance/material **211** extending from the first joint **207** to the second joint **208**. The (pliable) filling substance/material **211** doubles as a vibration-dampening material. The filling material **211** preferably has a high surface area that diffuses reflections and attenuates the linear vibrations (up and down the length of the metal tube) as the vibrations reflect off the surface. The filling material also has a rubber-like consistency, and the material also has significant mass. Given these characteristics, filling material may be preferably made of a relatively heavy foam rubber. A non-exhaustive list of possible filling material **211**, includes, but is not limited to, cork, foam, sponge, rubber and balsa wood.

[0045] The second collar **212** may be made of similar material as the first collar **204** and is screwed and glued on to the exposed threading of the pin holder **213**. The second collar **212** is also substantially cylindrical with an inner cylindrical bore provided through the second collar

212, with dimensions to fit over the exposed threading of the pin holder 213, when affixed thereto.

[0046] In yet another embodiment, the cue stick may be designed with multiple segments, each have different characteristics. As an example, the cue stick may comprise four quadrants, with one quadrant within the cue handle, representing the forearm portion of the cue stick, being made of the rigid material (or having a rigid inner core) with the characteristics of the metal tube 207, as described herein.

[0047] With reference now to FIG. 6, which illustrates an example inner metal tube 607 designed with holes within the surface. In the illustrative embodiment, the metal tube 607 is perforated (with holes) to reduce the effects of weight due to the density of the hard, tensile material from which the tube is made. The perforated design of the metal tube 607 enables greater control in the weight (per linear dimension/length) of the metal tube 607 and ultimately enables the cue handle to be designed with different exterior material, while also providing greater flexibility in determining a center of gravity and balance of the cue stick, as well as other functional benefits, all while maintaining the rigidity of the forearm section.

[0048] To maintain structural integrity along the longitudinal axis, the holes are arranged in a set pattern relative to each other. As illustrated with tube 607a, representing a first embodiment, substantially one half of the holes are arranged at 0, 90, 180, and 270 degrees, relative to a 0 degree (start) reference point. The remaining holes (i.e., the second half of the holes) are arranged (or made) at 45, 135, 225, and 305 degrees relative to the 0 degree reference point. In tube 607b, which providing a second embodiment, the holes are drilled at a smaller spacing around the diameter of the tube 607b. Thus, substantially one half of the holes in tube 607b are arranged (made) at 0, 45, 90, 135, 180, 225, 270, and 315 degrees, relative to a 0 degree (start) reference point. The remaining holes are arranged (or made) at 22.5, 67.5, 112.5, 157.5, 202.5, 247.5, and 292.5, and 337.5 degrees relative to the 0 degree reference point. The number of holes and the hole positions relative to each other is a design factor that is variable.

1. Example Method for Constructing a First-type Cue Handle

[0049] A method of making the above cue handle and cue stick and certain components thereof comprises a series of steps, which entails manufacturing the above handle in portions and then connecting or affixing and/or gluing the various portions together. According to one embodiment, and as illustrated by **FIGs. 4A** and **4B**, the individual components of the inner core **400** are manufactured according to pre-calculated dimensions, taking into consideration the relative weight of the wood (or other material) being utilized for the segments of the external casing. Certain physical characteristics, such as the bore of each component, width of the walls, the interior and exterior circumference of the inner wood core segment and of the metal tube, length of the segments relative to each other, the final dimensions of the cue handle, and the weight-balance-mass distribution characteristics desired, among others, are factored into the design of each of the multiple components. The individual components, and ultimately the cue handle, are thus engineered to account for the weight of all the materials in the final product and the placement and structure of specific materials to account for a pre-determined or desired center of gravity, mass distribution, overall weight, rigidity of the forearm, and other characteristics that affect the cue stick's playability. For example, the length of the metal tube may be adjusted to account for density of the exterior wood. As another example, in one embodiment, a combination of a carbon fiber tube and metal tube may be utilized in lieu of a single metal tube to provide greater flexibility of balance point determination, weight, and precision with respect to the cue handle's diameter size.

[0050] Once manufactured, the components of the complete inner core are assembled as shown in **FIG. 4B**. The assembly includes affixing the particular components to each other at the two joints via some form of coupling mechanism (e.g., utilizing high strength adhesive). Notably, as described below, the second-type cue handle comprises only a single, continuous, rigid metal tube as the rigid inner core. This single metal tube may be designed with holes to provide correct balance (with considerations of effective mass distribution for an optimal, effective center of mass) and weight characteristics as shown by **FIG. 6**. This embodiment eliminates the need for a separate wood segment and an fixed joint between the segments.

[0051] One example method by which the first-type cue handle described herein is manufactured is now presented. With the inner core dimensions established (length, diameter, weight, and circumference), the piece(s) of wood utilized to create the external casing is/are drilled to create an internal bore with consistent circumference. According to the illustrative embodiments, the longitudinal, external diameter ($D-\delta$; where D represents diameter and δ represents a delta that is subtracted from the value of D) of the inner core is minimally smaller than the longitudinal inner diameter (D) of the external casing. This is required so that the external casing may be placed over the inner core during assembly, but with just enough space to allow the connection between the inner core's external surface and the internal surface of the external casing is completed with little or no gaps between the surfaces. In one embodiment, for example, the external diameter of the inner core may be in the range of 95-97% of the inner diameter of the external casing. Finally, the first and second collars are placed over/on the first end of the wood core and the protruding extended end of the pin holder, respectively.

[0052] In one embodiment, the external, longitudinal surface of the inner core, and the internal, longitudinal surface of the exterior casing components are coated with an adhesive, such as epoxy resins, polyvinyl acetates, or polyurethane, for example. This non-exhaustive list of adhesives is provided solely for example, and not intended to limit the implementation of the method described herein to these small list of example adhesives. With the inner surface wet with the adhesive, the component parts of the external casing are slid on to the inner core, and then the first and second collars are screwed on to the respective threaded ends and tightened. The top collar and bottom collar are rotated to a tightness at which all connecting surfaces are flush against each other and extra adhesive is pressed out of the joints. All connecting pieces are squared relative to each other, and specifically the adjacent, connected pieces. The extra adhesive is wiped off of the external casing. The cue handle is then left for the adhesive to cure.

[0053] Once the adhesive cures, the external casing is rounded into the required shape using a lathe or other cutting or sanding tool to provide smooth consistency in the tapering of the various adjoining components of the external casing. The diameter of the components may be decreased by the use of a lathe to a predetermine size and to provide a substantially smooth exterior surface. Once the cue handle reaches the desired shape, weight, look, and consistency, the

rubber bumper is inserted (pressed or screwed) into the internal anchoring space in the exposed end of the wood core segment. In one embodiment, the cue handle may be additionally covered by an outer veneer or sleeve comprising decorative material.

[0054] It should be understood that the above method is one embodiment of many which may be utilized to manufacture and/or construct a cue handle having the characteristics described herein. The description of one such method is therefore not intended to be limiting on the invention, which generally covers all cue handles which exhibit the features described herein, and particularly the rigidity of the forearm by inserting a rigid inner core as a part of a complete inner core, which extends through the cue handle and multiple, different portions that each exhibit different characteristics and/or functionality. The invention this covers any such cue handle, regardless of the type of manufacture/construction method(s) utilized.

[0055] In one embodiment, the rubber bumper and spacers/rings may be provided solely for cosmetic purposes or aesthetic appeal. In another embodiment, given the potential to create different weight and balance points for the cue handle based on selected design characteristic, the location and or color of the spacers and/or the color of the rubber bumper may be utilized to provide/described additional functional features of the cue handle and/or cue stick, while providing aesthetic appeal. For example, different colors may be used for the rubber bumpers, where the color of the inserted rubber bumper defines the play characteristics such as weight and balance of the cue handle. This distinction would then be based on design controls, which is influenced by the types of materials utilized, the length of the metallic tube relative to the total length of the cue handle or to the inner wooden core, and the weight of the wood utilized for the external casing, among other design parameters and/or factors.

B) SECOND-TYPE CUE HANDLE (SINGLE MEMBER RIGID CORE CONSTRUCTION)

[0056] According to a first embodiment, the rigid inner core of the second-type cue handle is a single-member inner tube, made of a hard, tensile material that provides steel-like characteristics, including rigidity. In one implementation the inner tube is a metal tube, and in one embodiment of that implementation, the metal tube is a steel tube. Thus, the inner core comprises a single

rigid, metal tube with a first end disposed proximate to the posterior end of the cue stick handle and a second, opposing end disposed proximate to the anterior end of the cue stick handle.

[0057] With reference now to **FIG. 3** (and associated **FIGs. 3A, 3B** and **3C**), there is illustrated a cross sectional view of a second-type cue handle comprising a second-type, rigid inner core constructed from a single metal tube, with a rigidity similar to that of steel. **FIGs. 3A** and **3B** illustrated expanded views of sections of second type cue handle **300** at which the mating (i.e., joining or connecting) of connecting mechanisms and other inner core segments and/or components occur, respectively, at the first/anterior end **330** and second/posterior end **320** of the complete inner core. **FIG. 3C** illustrates an expanded view of a section of the single rigid inner core at which a change is made in the diameter of the bore, as a design feature.

[0058] In one embodiment, the metal tube is a steel tube that is manufactured with a specific bore and with specific dimensions for utilization as the inner core of the second-type cue handle. As shown, the longitudinal cross section of second-type cue handle **300** comprises the connected segments/components of external casing and a single rigid tube-like inner core, which is coupled to different connecting mechanisms at opposed ends of the cue handle. The combination of the connecting mechanisms coupled at respective ends to the single member, rigid inner core is collectively referred to herein as a complete inner core. However, portions of the connecting mechanisms protrude beyond the point at which the rigid inner core stops. In the illustrative embodiment, both of the connecting mechanisms extend laterally past the external casing.

[0059] As illustrated by **FIG. 3**, the single rigid inner core is a (metal) tube **340** that extends from the posterior end **320** to the anterior end **330** of the cue handle **300** and terminates at the connecting ends with a first connecting mechanism at the joint end of the cue handle **300** and a second connecting mechanism at the butt end of the cue handle **300**. The first connecting mechanism is referred to herein as a joint pin holder **312**, while the second connecting mechanism is referred to as a weight-and-balance screw holder **333**. The functionality of each connecting mechanism, which is directly related to the names attributed to each mechanism, will be described with specific reference to **FIGs. 3A** and **3B**, respectively.

[0060] While shown as extending a significant length of cue handle, other embodiments of the second-type cue handle may provide for a much shorted length of metal tube (340), extending primarily within the forearm section of cue handle. The remaining length of inner core may then be replaced with a rigid/hard wood segment or an extension provided by some other material other than tube (340). In one alternate embodiment, the metal tube 340 is designed to act as a through bolt with grooved/threaded ends that enable a screw-on cap to be threaded on to the butt end and a pin holder to be screwed-on to the joint end.

[0061] Turning now to **FIG. 3A**, which illustrates the connecting joint at which joint screw 314 is insertably coupled to joint pin holder 313, which is itself coupled to metal tube 340. In the provided embodiment, joint pin holder 313 includes a posterior portion/end, which is coupled/attached to the anterior end of metal tube 340. The mechanisms for coupling the two components may include a strong glue or epoxy and/or a thread mated with each other to ensure a rigid solid construction. As shown, pin holder provides an exposed end, opposed to the end coupled to metal tube 340. The exposed end has a larger exterior diameter with one surface facing the external casing 308 and providing a shoulder to buttress the edges of the adjacent segment of external casing 308. This construction of (joint) pin holder 313 affixed to the end of the rigid inner core, where the complete inner core then extends and provides an attachment (for the second collar 304) at the opposing end, enables the exposed end of the pin holder 313 to serve as the head of a bolt. During final stages of construction, a collar 304 is tightened onto the butt end of the bolt to hold the various components securely in place. Joint screw 314 has an exposed end extending laterally from the pin holder 313. In one embodiment the exposed end has radial threads for insertably coupling cue handle 300 to an appropriately-dimensioned female receptacle of a cue shaft. According to one embodiment, pin holder 313 is made of a phenolic, and may be either a canvas based phenolic or a liline based phenolic.

[0062] **FIG. 3B** provides an illustration of one method by which weight-and-balance screw holder 333 is coupled to metal tube 340 to provide the connective mechanism for completing the butt end of cue handle 300, in one embodiment. Weight-and-balance screw holder 332 comprises a first (anterior) connecting surface that is coupled to a metal tube 300 at the posterior end of metal tube. Weight-and-balance screw holder 332 also comprises an axial bore. A posterior end

of weight-and-balance screw holder **332** is exposed with a connecting surface **303**, which serves as the surface to which second collar **304** is coupled/attached. One segment of external casing **306** covers the connecting joint as well as the extended portion of weight-and-balance screw holder **332** up to the point of connection of the second collar **304**.

[0063] Metal tube **340** is drilled with a lathe or other cutting device to remove a substantial portion of the wall thickness and weight. This enables control of the total weight and center of mass (and mass distribution) during the design/manufacturing process. In one implementation, the resulting metal tube may have an outside diameter of 0.75 inches and an internal diameter of 0.68 inches. Of course, embodiments of the invention may be implemented with metal tubes having different inner and outer diameters, and the above example diameter measurements are provided solely for illustration and not intended to limit the invention. According to the illustrative embodiment, and as further depicted by **FIG. 3C**, the inner diameter of metal tube **340** may be variable, with some portions having a first inner diameter and other portions having a different inner diameter. As shown, the inner anterior portion of metal tube **340** has a first diameter **342**, which is smaller than second diameter **344** of the inner posterior portion of metal tube **340**. This deliberate reduction in the thickness of the walls (resulting from the increase in the interior diameter) of metal tube **340**, at the butt end of cue handle **300**, results in decreased weight, while maintaining the rigidity desired in the forearm of the cue handle. Thus, the rigidity associated with the metal tube **340** remains substantially on the order of one third the rigidity associated with a solid steel rod of the same outside diameter.

[0064] The resulting decrease in weight of the metal tube **340** (after cutting or scurrying away wall thickness) within the design process enables greater control of the weight of the cue handle, and further enables weight and balance (and mass distribution for an optimal center of mass) determinations to be made post manufacture/design. Looking again at **FIGs. 3** and **3B**, in one embodiment, at least some portion of metal tube **340** is filled with vibration dampening/absorbing material **311**, which may comprise any of the aforementioned dampeners, such as sound dampening foam.

[0065] According to one implementation and as shown by **FIG. 3B**, an internal/axial chamber is provided within weight-and-balance screw holder **332**. In one embodiment, this axial chamber can be utilized by the manufacturer and/or user of cue handle **300** to selectively insert a weighted bolt/screw **334** inside of the axial chamber within the weight-and-balance screw holder **333**. The weighted bolt/screw may be of a predefined weight and capable of adjusting the overall weight of the assembled cue stick by a measurable percentage (e.g., +/- 10%). Rubber bumper **302** is inserted into the open end of weight-and-balance screw holder **332**, thus completing the finished look of the cue handle **300**. As shown, both weight screw/bolt **334** and rubber bumper **302** are rotatably inserted into the threaded inner surface of weight-and-balance screw holder **333**, while collar **304** is screwed on to the exposed external grooves/threads **303** of weight-and-balance screw holder **333**.

C) CUE STICK AND PLAY CHARACTERISTICS

[0066] When constructed in either of the above manners, both first-type and second-type cue handles provide an inner core construction that provides a rigidity that is on the range of 5 times more rigid than hardwood maple or ash, which are commonly utilized within convention cue handle designs.

[0067] As shown in **FIG. 5**, once manufacture is completed, cue handle **200** may be attached to any one of the available cue shafts **501** to provide a complete cue stick **500**. Preferably, the cue shaft utilized is a cue shaft (**501**) designed according to U.S. Patent Application No. 2006/0205525, of common inventorship herewith. Relevant content of that patent application is incorporated herein by reference. With the cue handle **100** designed according to embodiments of the current invention, the cue stick **500** exhibits minimal flex in the axial direction. The axial stiffness serves to maintain satisfactory transmission of momentum axially when the cue stick **500** strikes a ball.

[0068] Further, given the specific designs of the cue handle, the cue stick would exhibit several desired functional characteristics, such as: (a) predictable and/or optimal weight and balance (or center of gravity) and mass distribution; (b) radial consistency (feel and performance); (c) vibration dampening; (d) high tensile strength; (e) stiffness/rigidity along the forearm section of

the cue handle; and (f) simplicity of assembly. Further, regardless of the specific design of the cue handle, the handle provides the look and feel of solid wood, while playing with the strength and durability and other functional characteristics (typically attributable to metallic substances, such as steel) that are desired, but only attainable using the designed described herein.

[0069] While the invention has been described with reference to exemplary embodiments, it will be understood by those skilled in the art that various changes may be made and equivalents may be substituted for elements thereof without departing from the scope of the invention. In addition, many modifications may be made to adapt a particular system, device or component thereof to the teachings of the invention without departing from the essential scope thereof. Therefore, it is intended that the invention not be limited to the particular embodiments disclosed for carrying out this invention, but that the invention will include all embodiments falling within the scope of the appended claims. Moreover, the use of the terms first, second, etc. do not denote any order or importance, but rather the terms first, second, etc. are used to distinguish one element from another.

[0070] While the invention has been particularly shown and described with reference to a preferred embodiment, it will be understood by those skilled in the art that various changes in form and detail may be made therein without departing from the spirit and scope of the invention.

CLAIMS

What is claimed is:

1. A cue stick handle having a longitudinal length extending from a joint screw end to a butt end, said cue stick handle comprising:

a hollow exterior casing comprising one or more rigid, conical members extending along a substantial portion of the longitudinal length; and

an inner core constructed with a plurality of interconnected components, including a rigid inner core confined within the hollow exterior casing for a first length that extends between an anterior end, which is proximate to the joint screw end, and an opposed posterior end, which is proximate to the butt end, wherein said rigid inner core is made of a hard, tensile material that has structural characteristics of rigidity that are substantially similar to steel and enables the cue stick handle to exhibit such structural characteristics in at least a forearm section of the cue handle, while other components of the inner core exhibit different structural and functional characteristics.

2. The cue stick handle of Claim 1, wherein the interconnected components comprise:

a joint pin holder composed of a strong composite or plastic material, having high tensile and high bending strength, and which is coupled via a first portion to the anterior end of the rigid inner core and which includes a second portion opposed to the first portion that has a laterally extended surface and a bore extending through the first portion and the second portion; and

a joint pin having a first end securely inserted within the bore of the pin holder and an exposed, second end that extends in an axial direction away from the pin holder and the rigid inner core, wherein said joint pin is made with one of a hard metal, a hard metal-like material, fiber glass, or carbon fiber composite, and provides a connecting point at which a cue shaft may be readily engaged to and disengaged from the cue stick handle;

wherein the joint pin holder is made of a material that includes at least one of a composite, fiber glass epoxy material or a phenolic, which material exhibits strength substantially higher than wood to provide enhanced strength at a joint of the cue handle and enhanced strength of a resulting cue stick when a cue shaft is attached at the joint pin.

3. The cue stick handle of Claim 1, wherein the interconnected components comprise:
a weight-and-balance pin holder having an anterior portion and a posterior portion with an inner axial bore extending along the center of the weight-and-balance pin holder, said weight-and-balance pin holder being coupled at the anterior portion to the posterior end of the rigid inner core, and wherein said weight-and-balance pin holder enables selective insertion of a weight-and-balance adjustment pin inserted into the inner axial bore of the weight-and-balance pin holder.
4. The cue stick handle of Claim 3, further comprising:
a weight-and-balance adjustment pin inserted into the inner axial bore of the weight-and-balance pin holder, wherein a specific weight-and-balance adjustment pin is selected based on a consideration of distributed weight, balance, and effective center of gravity desired for the cue stick handle when assembled with a cue shaft to form a cue stick; and
a tightening mechanism affixed to the posterior portion of the weight-and-balance pin holder and which securely fastens internal and external components of the cue stick handle and substantially eliminate movement of the internal and external components relative to each other.
5. The cue stick handle of Claim 4, wherein:
the rigid inner core has an axial bore within at least one of the anterior end and the posterior end; and
at least one interconnected component is coupled to the rigid inner core via insertion of an extended portion of the at least one interconnected component into the axial bore at a corresponding end of the rigid inner core.
6. The cue stick handle of Claim 5, wherein the rigid inner core is a steel tube.
7. The cue stick handle of Claim 5, wherein the rigid inner core comprises a rigid tube and the axial bore extends through the entire length of the rigid tube.
8. The cue stick handle of Claim 7, wherein the rigid inner core further comprises a pliable filling material disposed within the rigid tube, which provides noise and vibration-

dampening during use of the cue stick handle, wherein the filling material has a rubber-like consistency and significant mass.

9. The cue stick handle of Claim 7, wherein a wall of the rigid tube is perforated with multiple holes to enable control of weight characteristics of the rigid inner core and the cue stick handle.

10. The cue stick handle of Claim 7, wherein a relative thickness of a wall of the rigid, tube is less at the posterior end of the rigid tube than at the anterior end of the rigid tube.

11. A cue stick comprising: a cue handle designed according to Claim 1; and a cue shaft having a first end and a second end disposed from the first end, said first end having a tip for striking a cue ball, and said second end having one of: a receptacle for receiving an insertion of a joint pin extending from an anterior end of the inner core of the cue handle; or a joint pin extending from the second end and being utilized to insertably attach the cue shaft to the cue handle, wherein the cue handle includes a joint pin holder with an axial bore for receiving a joint pin from a cue shaft.

12. A cue stick comprising: a cue handle designed according to Claim 2; and a cue shaft having a first end and a second end disposed from the first end, said first end having a tip for striking a cue ball, and said second end having a receptacle for receiving an insertion of the joint pin.

13. The cue stick handle of Claim 1, wherein the interconnected components are linearly coupled via one or more mechanisms at the anterior end and the posterior end of the rigid inner core, said mechanisms enabling a substantially permanent attachment of the rigid inner core to other components and includes one or more of (a) threaded grooves on end surfaces of the rigid inner core interlocked with threads on a portion of a component attached to the respective end surface of the rigid inner core, or vice versa; and (b) a mastic applied between connecting surfaces of the rigid inner core and adjacent surfaces of a component coupled to the connecting surface.

14. A method of making a cue stick handle, said method comprising:
securely attaching components of an inner core to each other in a linear configuration, wherein the components of the inner core includes:
a rigid inner core having a first, anterior connecting end and a second, posterior connecting end, wherein said rigid inner core is made of a hard, tensile material that provides steel-like characteristics, including rigidity and which reinforces a forearm section of the cue stick handle;
a first component and a second component, securely coupled in a linear orientation to respective ones of the first connecting end and the second connecting end of the rigid inner core;
wherein at least one of the first component and the second component is made of a different material than the rigid inner core and exhibits different structural and functional characteristics than the rigid inner core;
wherein each component of the cue stick handle is made of a selected material, which is pre-selected based on functional characteristics of the material, including tensile strength, and desired characteristics of the cue stick, from among physical dimensions, weight and balance, center of gravity, to provide a cue stick having pre-determined physical and functional characteristics; and
securely bonding the inner core within an internal cylindrical bore of a tapered external casing extending along a substantial portion of a length of the inner core, said external casing having at least one segment configured in a conical configuration with a conical exterior surface.

15. The method of Claim 14, wherein:
the first component is a joint pin holder, said second component is a weight-and-balance pin holder; and
said method further comprises:
selecting a rigid tube as the rigid inner core for the cue stick handle, said rigid tube being substantially cylindrical;
securely coupling the joint pin holder and a weight-and-balance pin holder to opposite ends of the rigid tube in a linear configuration, wherein the joint pin holder is made up of a

strong composite or plastic material, having a high tensile and high bending strength, and coupled via respective coupling portions to the opposing ends of the rigid tube;

securely inserting a joint screw into an exposed portion of the joint pin holder, said joint screw being inserted into an axial bore of the joint pin holder and having an exposed portion extending externally from the joint pin holder and exposed at the end of the cue stick handle; and

securely bonding the rigid tube and portions of the joint pin holder and weight-and-balance pin holder to an internal surface of an external casing, said external casing comprised of at least one segment configured in a conical configuration with a consistently-tapered exterior surface.

16. The method of Claim 15, wherein said securely coupling, securely inserting, and securely bonding comprises:

applying a high strength adhesive along at least one of (a) an exterior surface of the rigid, inner tube, (b) the internal surface of the external casing, (c) connecting surfaces of the joint pin holder and weight-and-balance pin holder, which connect to respective inner or outer surfaces of the rigid tube, and (d) the connecting surface within the axial bore of the joint pin holder and a surface of the joint pin;

mating at least one threaded collar over an exposed threaded end of the weight-and-balance pin holder to secure the rigid, inner tube and the exterior casing in place and prevent movement of components of the cue stick handle relative to each other.

17. The method of Claim 15, further comprising:

inserting a selected weight and balance pin into an axial bore at an exposed end of the weight-and-balance pin holder, wherein the weight and balance pin is selected based on desired weight and balance characteristics desired to be exhibited by a cue stick assembled with the cue stick handle.

18. The method of Claim 15, further comprising:

inserting a pliable filling material disposed within the rigid tube, which material provides vibration-dampening during use of the cue stick handle by attenuating noise and linear vibrations

that reflect off a surface of the rigid, inner metal tube, wherein the filling material has a rubber-like consistency and significant mass.

19. The method of Claim 15, further comprising:

perforating a wall of the rigid tube with multiple holes in a first configuration that enables control of weight characteristics of the rigid inner core and the cue stick handle, while maintaining structural characteristics, including rigidity and strength.

20. The method of Claim 15, further comprising:

selectively removing a portion of an inner wall of the rigid tube along a posterior end of the rigid tube, such that a wall thickness at the posterior end of the rigid tube is less than the wall thickness at the anterior end of the rigid tube.

21. A cue stick handle having a longitudinal length extending from a joint screw end to a butt end, said cue stick handle comprising:

a hollow exterior casing comprising one or more rigid, conical members extending along a substantial portion of the longitudinal length; and

an inner core constructed with a plurality of interconnected components, including a rigid inner core confined within the hollow exterior casing for a first length between the joint screw end and the butt end, wherein said rigid inner core is made of a hard, tensile material that has structural characteristics of rigidity that are substantially similar to steel and enables the cue stick handle to exhibit such structural characteristics in at least a forearm section of the cue handle, while other components of the inner core exhibit different structural and functional characteristics.

22. The cue stick handle of Claim 21, wherein the rigid inner core is a first portion of a longer inner core that comprises two or more linearly interlocked and glued components providing a first anterior end and a second posterior end opposed to the first anterior end.

23. The cue stick handle of Claim 22, wherein:

the rigid inner core has a first structural design at a posterior end and a second structural design at an anterior end to enable connection of the rigid inner core to other components of the inner core at opposing ends of the rigid inner core; and

the longer inner core includes a second rigid core segment with a first end fixably attached to the posterior end of the rigid inner core and which has a connecting surface at a second, opposed end to provide the second posterior end of the longer inner core.

24. The cue stick handle of Claim 23, wherein the second rigid core segment is wood and the second rigid core segment has a posterior end that couples to a second collar.

25. The cue stick handle of Claim 23, wherein the inner core further comprises:

a pin holder composed of a strong composite or plastic material, having a high tensile and high bending strength, and which is coupled via a first portion to the anterior end of the rigid inner core and which includes a second portion opposed to the first portion that has a laterally extended surface and a bore extending through the first portion and the second portion; and

a joint pin having a first end securely inserted within the bore of the pin holder and an exposed, second end that extends in an axial direction away from the pin holder and the rigid inner core, wherein said joint pin is made with one of a hard metal or a hard metal-like material and provides a connecting point at which a cue shaft may be readily engaged to and disengaged from the cue stick handle;

wherein the pin holder is made of at least one of a composite, fiber glass epoxy material or a phenolic which exhibits strength substantially higher than wood to provide enhanced strength at a joint of the cue handle and enhance a strength of a resulting cue stick when a cue shaft is mated on the joint pin.

26. The cue stick handle of Claim 25, wherein:

the rigid inner core is a tube with an axial bore within at least the anterior end;

the first structural design comprises coupling means for securely coupling the second core segment to the posterior end of the rigid inner core; and

the second structural design comprises coupling means for securely coupling the pin holder to the anterior end of the rigid inner core, wherein the first portion of the pin holder is an extended surface that is insertably coupled to the interior bore at the anterior end of the tube.

27. The cue stick handle of Claim 26, wherein the rigid inner core is a steel tube.
28. The cue stick handle of Claim 21, said rigid inner core comprising a rigid tube with a first end disposed proximate to an anterior end of the cue stick handle and a second, opposing end disposed proximate to a posterior end of the cue stick handle.
29. The cue stick handle of claim 21, further comprising a pair of collars mated to each end of the inner core to secure the inner core inside of the exterior casing, wherein the pair of collars comprises:
- a first collar mated to a first anterior end of the inner core; and
 - a second collar mated to a second posterior end of the inner core, which second posterior end is the extended surface of a joint pin holder.
30. The cue stick handle of Claim 22, wherein the rigid inner core further comprises a pliable filling material disposed within the tube, which provides noise and vibration-dampening during use of the cue stick handle, wherein the filling material has a rubber-like consistency and significant mass.
31. A cue stick comprising: a cue handle designed according to Claim 21; and a cue shaft having a first end and a second end disposed from the first end, said first end having a tip for striking a cue ball, and said second end having one of: a receptacle for receiving a mating of a joint pin extending from the inner core of the cue handle; or a joint pin fixable attached and extending from the second end for insertably coupling the cue shaft to an axial bore within a joint pin holder attached to an anterior end of the rigid inner core of the cue handle.
32. A cue stick comprising: a cue handle designed according to Claim 25; and a cue shaft having a first end and a second end disposed from the first end, said first end having a tip for

striking a cue ball, and said second end having a receptacle for receiving a mating of the joint pin.

33. A method of making a cue stick handle, said method comprising:

securely attaching components of an inner core to each other in a linear configuration, wherein the rigid inner core includes:

two or more linearly coupled components providing a first connecting end and a second connecting end opposed to the first connecting end, said two or more components includes:

a rigid inner core made of a hard, tensile material that provides steel-like characteristics including rigidity and which reinforces a forearm section of the cue stick handle; and

at least one second core structure made of a different material than the rigid inner core and which exhibits different structural and functional characteristics than the rigid inner core; and

securely bonding the inner core within an internal cylindrical bore of a tapered external casing extending along a substantial portion of a length of the inner core, said external casing having at least one segment configured in a conical configuration with a conical exterior surface.

34. The method of Claim 33, wherein said securely affixing the inner core includes one or more of:

applying a high strength adhesive along at least one of (a) an exterior surface of the inner core and (b) an interior surface of the internal cylindrical bore; and

attaching a pair of collars over each end of the inner core to secure the inner core inside of the external casing.

35. The method of Claim 33, further comprising:

wherein components of the cue handle are made of different materials, which are pre-selected based on structural and functional characteristics of the selected materials, including tensile strength and weight, in order to provide a cue stick having pre-determined and desired characteristics such as rigidity of the forearm, specific physical dimensions of length and circumference/diameter, weight and balance, mass distribution, and center of gravity.

36. The method of Claim 33, wherein the at least one second core structure of the inner core comprises:

a pin holder made of a strong composite or plastic material, having a high tensile and high bending strength, and which (a) is coupled via a first portion to a first anterior end of the rigid inner core and (b) has an extended surface opposed to the first portion and (c) has a bore extending axially through the first portion and the extended surface; and

a joint pin having a first end securely inserted into the bore of the pin holder and a second end extending axially away from the pin holder and rigid inner core.

37. The method of Claim 33, wherein the at least one second core structure of the inner core comprises:

a second rigid core segment with a first end fixably attached to a posterior end of the rigid inner core and which provides a coupling mechanism at a second opposed end to provide the second connecting end of the inner core;

wherein the second rigid core segment is a wood core, which has a coupling mechanism at a posterior end for attaching to a surface of a second collar.

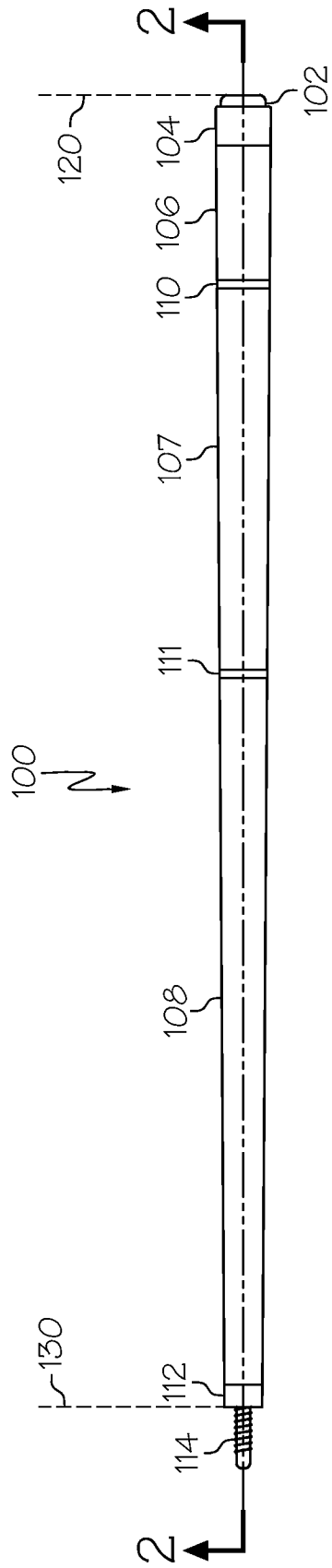

FIG. 1

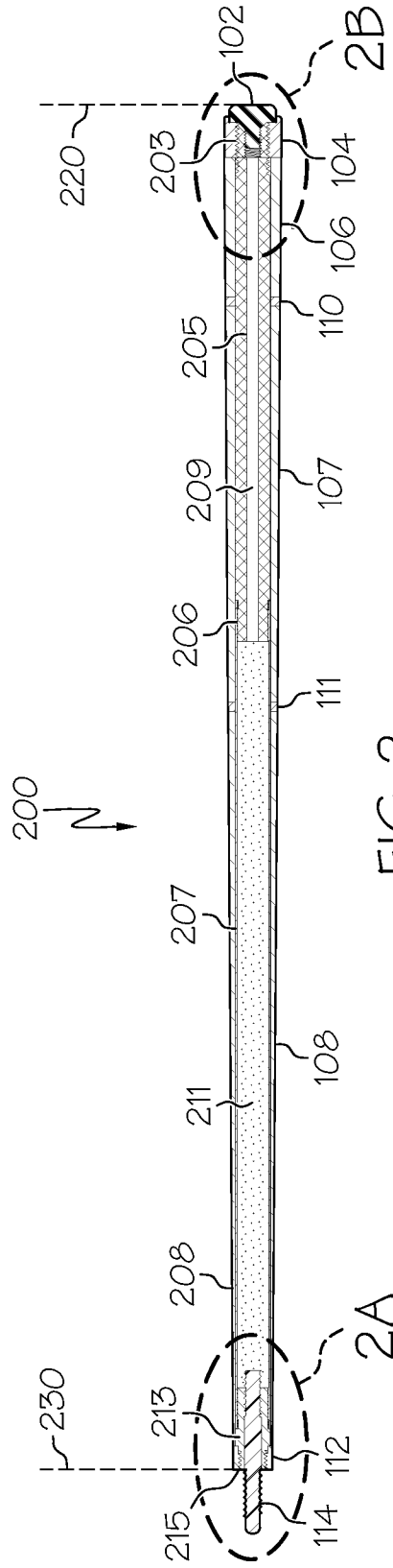

FIG. 2

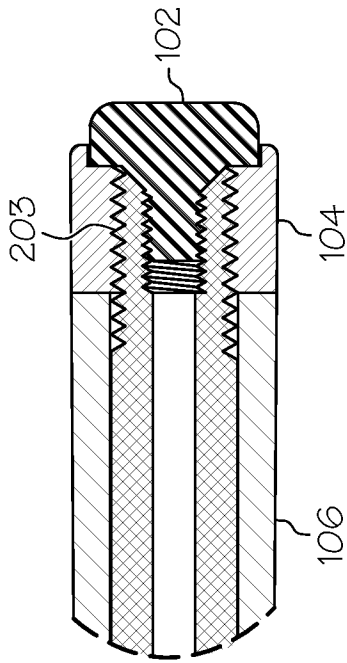

FIG. 2B

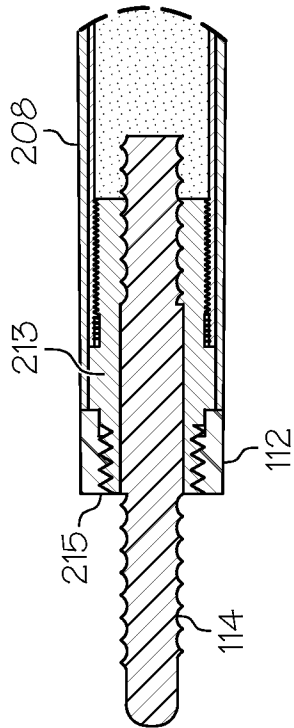

FIG. 2A

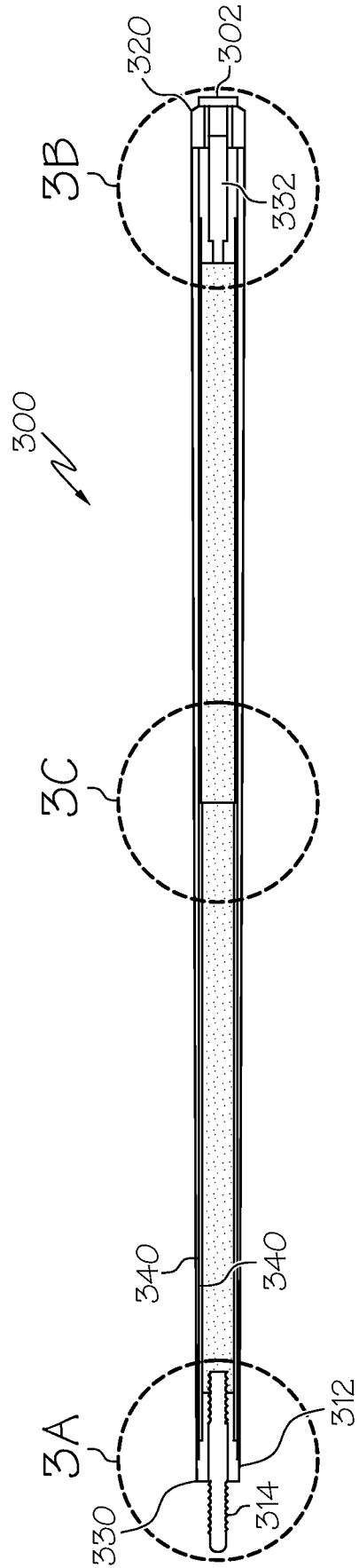

FIG. 3

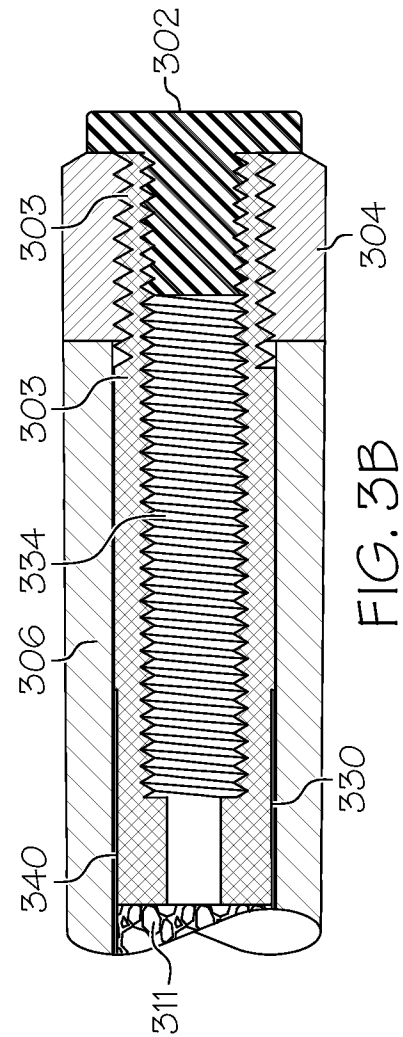
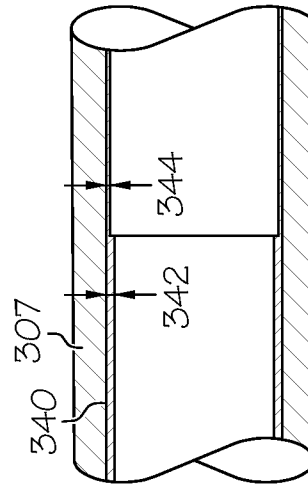
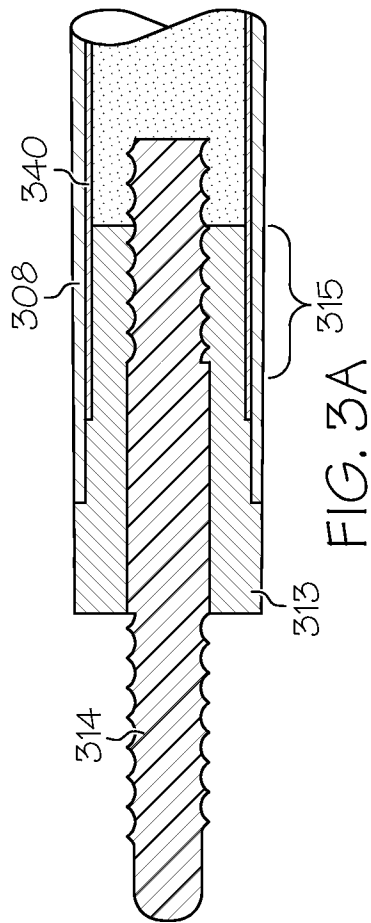

FIG. 3C

FIG. 3B

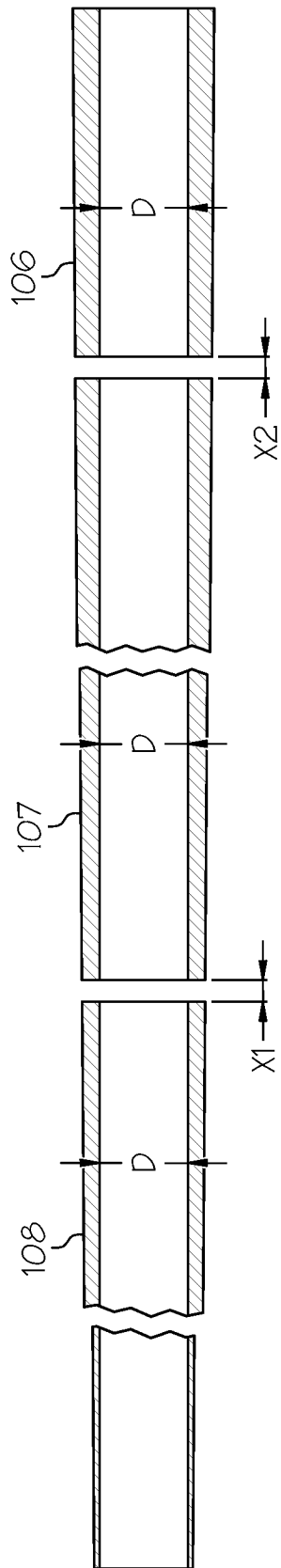

FIG. 4A

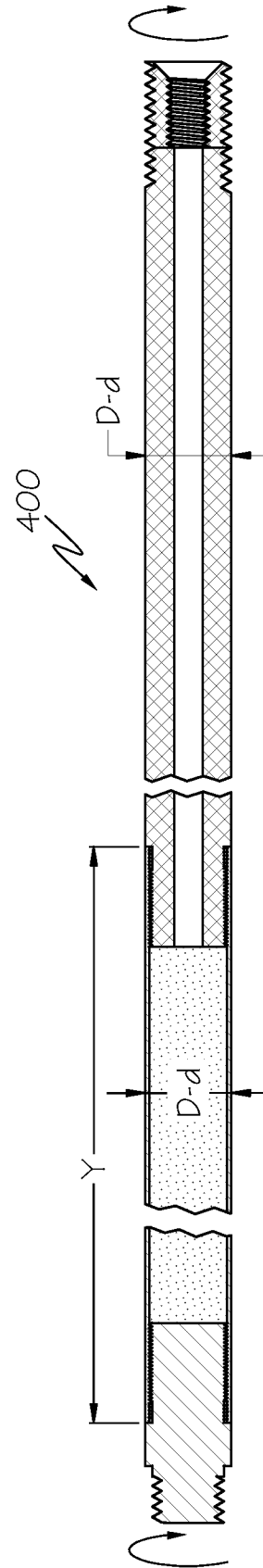

FIG. 4B

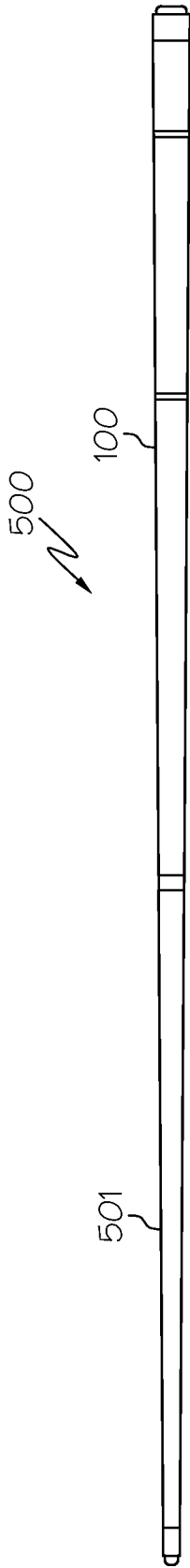

FIG. 5

5 / 5

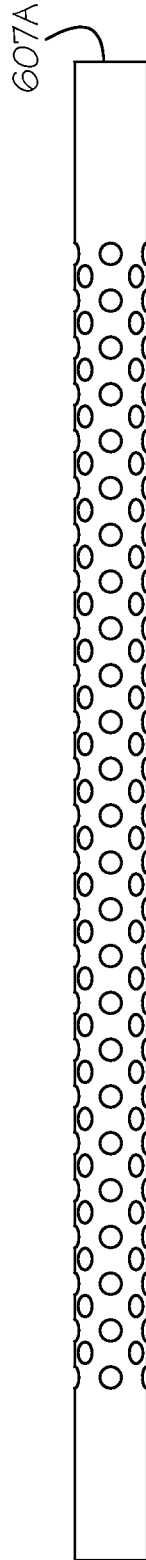

FIG. 6A

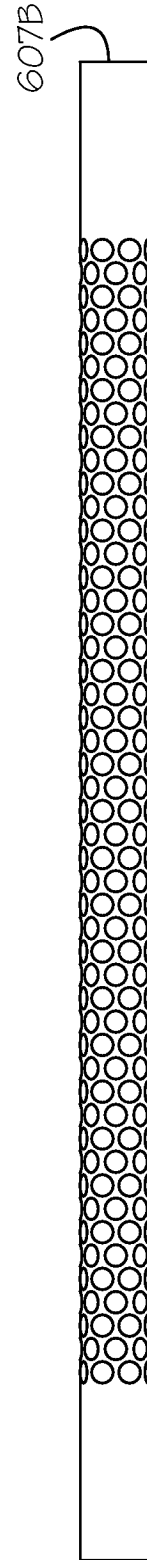

FIG. 6B

INTERNATIONAL SEARCH REPORT

International application No.

PCT/US2008/081354

A. CLASSIFICATION OF SUBJECT MATTER IPC(8) - A63D 15/08 (2008.04) USPC - 473/44 According to International Patent Classification (IPC) or to both national classification and IPC		
B. FIELDS SEARCHED Minimum documentation searched (classification system followed by classification symbols) IPC(8) - A63D 15/08 (2008.04) USPC - 473/44,45,47 Documentation searched other than minimum documentation to the extent that such documents are included in the fields searched Electronic data base consulted during the international search (name of data base and, where practicable, search terms used) USPTO EAST System (US, USPG-PUB, EPO, DERWENT), MicroPatent.		
C. DOCUMENTS CONSIDERED TO BE RELEVANT		
Category*	Citation of document, with indication, where appropriate, of the relevant passages	Relevant to claim No.
X	US 4,949,964 A (JOLLY) 21 August 1990 (21.08.1990) entire document	1,3-7,10,13,14,21-23,28,33-35
Y		2,8,9,11,12,15-20,24-27,29-32,36,37
Y	US 5,643,095 A (PROBST) 01 July 1997 (01.07.1997) entire document	2,11,12,24-27,29,31-32,36,37
Y	US 2006/0205525 A1 (OWEN) 14 September 2006 (14.09.2006) entire document	8,18,30
Y	US 2002/0072423 A1 (POT) 13 June 2002 (13.06.2002) entire document	9,19
Y	US 2005/0043107 A1 (KUO) 24 February 2005 (24.02.2005) entire document	15-20
<input type="checkbox"/> Further documents are listed in the continuation of Box C. <input type="checkbox"/>		
* Special categories of cited documents: "A" document defining the general state of the art which is not considered to be of particular relevance "E" earlier application or patent but published on or after the international filing date "L" document which may throw doubts on priority claim(s) or which is cited to establish the publication date of another citation or other special reason (as specified) "O" document referring to an oral disclosure, use, exhibition or other means "P" document published prior to the international filing date but later than the priority date claimed "T" later document published after the international filing date or priority date and not in conflict with the application but cited to understand the principle or theory underlying the invention "X" document of particular relevance; the claimed invention cannot be considered novel or cannot be considered to involve an inventive step when the document is taken alone "Y" document of particular relevance; the claimed invention cannot be considered to involve an inventive step when the document is combined with one or more other such documents, such combination being obvious to a person skilled in the art "&" document member of the same patent family		
Date of the actual completion of the international search 09 December 2008		Date of mailing of the international search report 24 DEC 2008
Name and mailing address of the ISA/US Mail Stop PCT, Attn: ISA/US, Commissioner for Patents P.O. Box 1450, Alexandria, Virginia 22313-1450 Facsimile No. 571-273-3201		Authorized officer: Blaine R. Copenheaver PCT Helpdesk: 571-272-4300 PCT OSP: 571-272-7774