



(12) **EUROPEAN PATENT APPLICATION**

(88) Date of publication A3:
30.08.2006 Bulletin 2006/35

(51) Int Cl.:
E03D 13/00 (2006.01)

(43) Date of publication A2:
17.05.2006 Bulletin 2006/20

(21) Application number: **05256967.0**

(22) Date of filing: **11.11.2005**

(84) Designated Contracting States:
**AT BE BG CH CY CZ DE DK EE ES FI FR GB GR
HU IE IS IT LI LT LU LV MC NL PL PT RO SE SI
SK TR**

Designated Extension States:
AL BA HR MK YU

(72) Inventor: **Cummings, Stephen John
Newport 2106
New South Wales (AU)**

(74) Representative: **Godwin, Edgar James
Marks & Clerk
90 Long Acre
London WC2E 9RA (GB)**

(30) Priority: **15.11.2004 AU 2004906532**

(71) Applicant: **CAROMA INDUSTRIES LIMITED
Brisbane,
Queensland 4000 (AU)**

(54) **A removable cartridge assembly for a waterless urinal**

(57) A removable cartridge assembly (16) for a waterless urinal (10). The cartridge assembly (16) comprises a cup (42) and a cap (46). The cup (42) is adapted to receive a scent block (44) therein. The cap (46) is adapted to releasably engage the cup (44). When the cap (46) is engaged with the cup (42), the scent block (44) is retained in the cup (42) and, when the cap (46) is disengaged from the cup (42), the scent block (44) is removable from within the cup (42), and thus from the cartridge assembly (16).

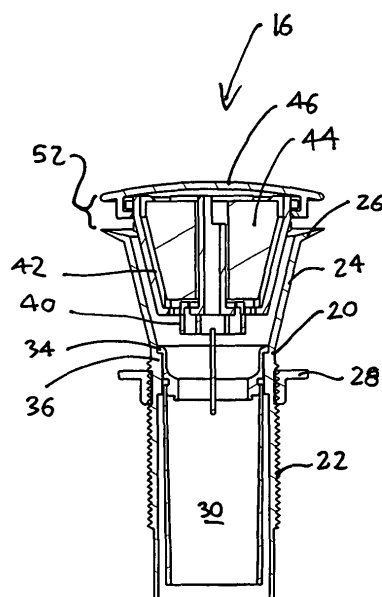

FIG. 6



DOCUMENTS CONSIDERED TO BE RELEVANT			
Category	Citation of document with indication, where appropriate, of relevant passages	Relevant to claim	CLASSIFICATION OF THE APPLICATION (IPC)
X	US 2004/181861 A1 (INGLIN URS ET AL) 23 September 2004 (2004-09-23) * paragraph [0002]; figure 1 * * paragraph [0010] * * paragraph [0012] * -----	1-4,6,8,9	INV. E03D13/00
X	FR 2 423 595 A (ERNST ING AG F) 16 November 1979 (1979-11-16) * page 1, line 1 - line 8 * -----	10-15	
A	US 6 401 266 B1 (MITCHELL GEOFF JOHN ET AL) 11 June 2002 (2002-06-11) * figures 4-6 * -----	1-4,6,8,9,11-15	
The present search report has been drawn up for all claims			TECHNICAL FIELDS SEARCHED (IPC)
			E03D
Place of search		Date of completion of the search	Examiner
Munich		13 March 2006	Flygare, E
<p>CATEGORY OF CITED DOCUMENTS</p> <p>X : particularly relevant if taken alone Y : particularly relevant if combined with another document of the same category A : technological background O : non-written disclosure P : intermediate document</p> <p>T : theory or principle underlying the invention E : earlier patent document, but published on, or after the filing date D : document cited in the application L : document cited for other reasons & : member of the same patent family, corresponding document</p>			

EPO FORM 1503 03.02 (P04C01)

**CLAIMS INCURRING FEES**

The present European patent application comprised at the time of filing more than ten claims.

- Only part of the claims have been paid within the prescribed time limit. The present European search report has been drawn up for the first ten claims and for those claims for which claims fees have been paid, namely claim(s):
- No claims fees have been paid within the prescribed time limit. The present European search report has been drawn up for the first ten claims.

LACK OF UNITY OF INVENTION

The Search Division considers that the present European patent application does not comply with the requirements of unity of invention and relates to several inventions or groups of inventions, namely:

see sheet B

- All further search fees have been paid within the fixed time limit. The present European search report has been drawn up for all claims.
- As all searchable claims could be searched without effort justifying an additional fee, the Search Division did not invite payment of any additional fee.
- Only part of the further search fees have been paid within the fixed time limit. The present European search report has been drawn up for those parts of the European patent application which relate to the inventions in respect of which search fees have been paid, namely claims:
- None of the further search fees have been paid within the fixed time limit. The present European search report has been drawn up for those parts of the European patent application which relate to the invention first mentioned in the claims, namely claims:

1-15



The Search Division considers that the present European patent application does not comply with the requirements of unity of invention and relates to several inventions or groups of inventions, namely:

1. claims: 1-15

A removable cartridge assembly comprising a cup and a cap
and a waterless urinal comprising the removable cartridge
assembly

2. claims: 16-18

A waterless urinal cartridge assembly removal and
installation tool comprising a first and a second end

**ANNEX TO THE EUROPEAN SEARCH REPORT
ON EUROPEAN PATENT APPLICATION NO.**

EP 05 25 6967

This annex lists the patent family members relating to the patent documents cited in the above-mentioned European search report. The members are as contained in the European Patent Office EDP file on
The European Patent Office is in no way liable for these particulars which are merely given for the purpose of information.

13-03-2006

Patent document cited in search report	Publication date	Patent family member(s)	Publication date
US 2004181861 A1	23-09-2004	EP 1460187 A1	22-09-2004
FR 2423595 A	16-11-1979	AT 366127 B	10-03-1982
		AT 442378 A	15-07-1981
		BE 875563 A1	31-07-1979
		CH 632033 A5	15-09-1982
		DE 2816597 B1	06-09-1979
		DK 150979 A	18-10-1979
		NL 7902874 A	19-10-1979
US 6401266 B1	11-06-2002	AU 740385 B2	01-11-2001
		AU 8548798 A	01-03-1999
		BG 63757 B1	29-11-2002
		BG 104215 A	29-12-2000
		CA 2299509 A1	18-02-1999
		CN 1268203 A	27-09-2000
		CZ 20000358 A3	12-09-2001
		DE 1012413 T1	14-11-2002
		EA 2493 B1	27-06-2002
		EP 1012413 A1	28-06-2000
		WO 9907953 A1	18-02-1999
		HU 0003469 A2	28-02-2001
		NO 20000505 A	03-04-2000
		NZ 502850 A	25-10-2002
		PL 338559 A1	06-11-2000
		SK 1682000 A3	12-09-2000
		TR 200000318 T2	22-05-2000
		ZA 9806946 A	02-02-1999