

F. M. F. CAZIN.
MATRIX MAKING MACHINE.

No. 435,344.

Patented Aug. 26, 1890.

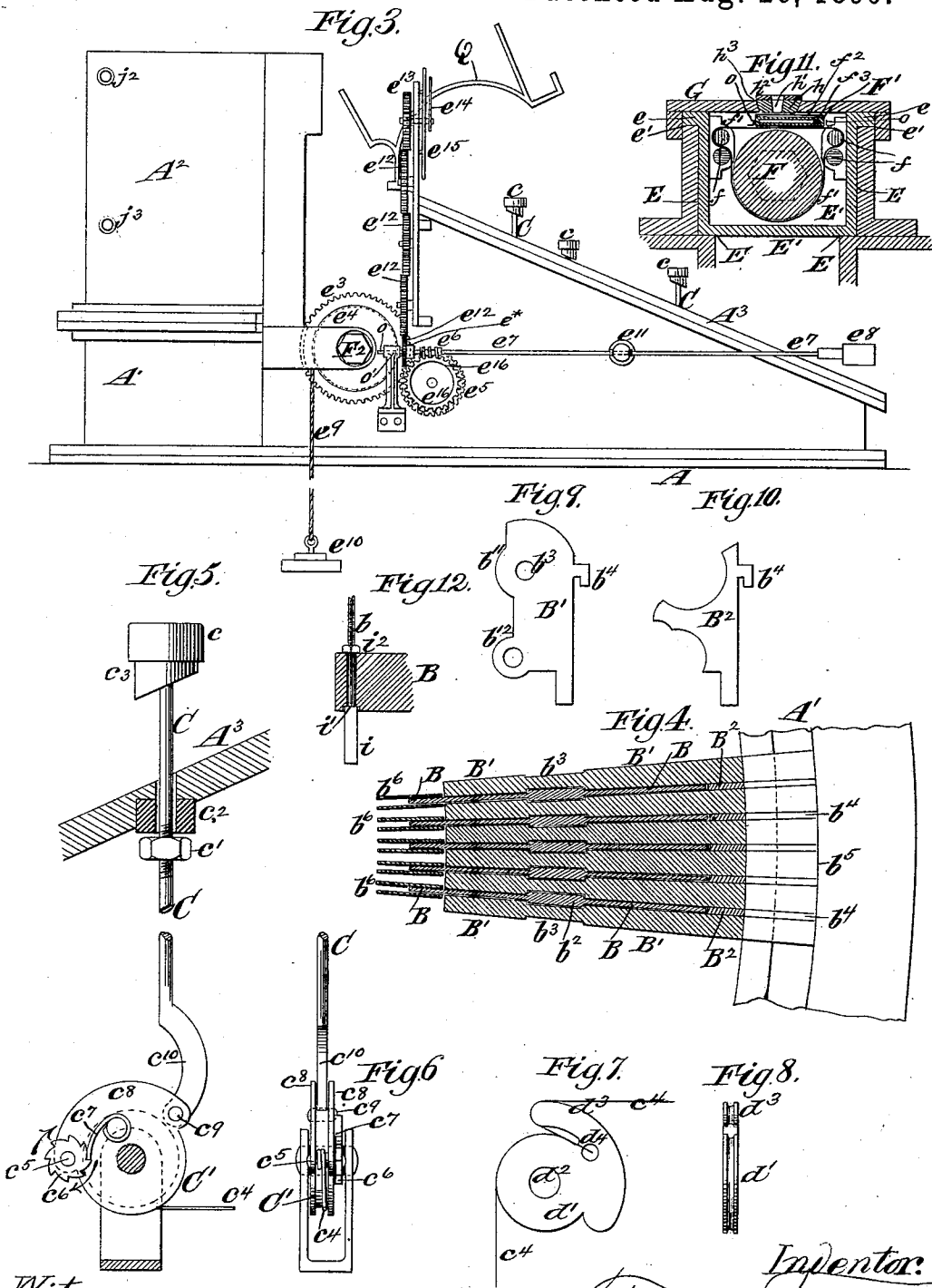

Witnesses.
 Emil Hester
 O. Sundgren

Inventor:
 Francis M. F. Cazin
 by his attys
 Crown Hall

(No Model.)

3 Sheets—Sheet 3.

F. M. F. CAZIN.
MATRIX MAKING MACHINE.

No. 435,344.

Patented Aug. 26, 1890.

Fig. 14.

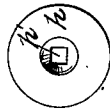
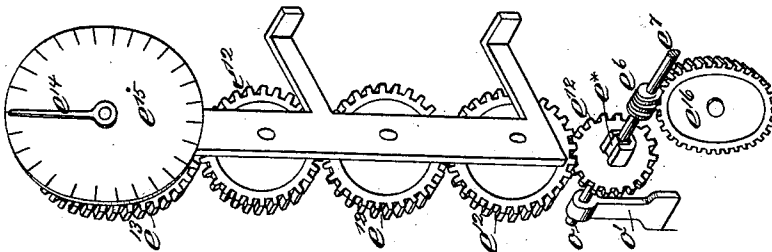

Fig. 13.



Witnesses:

O. Sundgren
Arthur H. Gamblin.

Inventor
Francis M. F. Cazin.
by his Attorney,
Brown & Griswold

UNITED STATES PATENT OFFICE

FRANCIS M. F. CAZIN, OF NEW YORK, N. Y.

MATRIX-MAKING MACHINE.

SPECIFICATION forming part of Letters Patent No. 435,344, dated August 26, 1890.

Application filed January 27, 1887. Serial No. 225,626. (No model.)

To all whom it may concern:

Be it known that I, FRANCIS M. F. CAZIN, of the city and county of New York, in the State of New York, have invented a new and useful Improvement in Matrix-Making Machines, of which the following is a specification.

I will describe in detail a machine for producing matrices embodying my improvement, and then point out the novel features in claims.

It is advantageous to have the punches hot, as if the matrix is of moist material the heat imparted to it by the punches will tend to dry the surfaces of the impressions, and if of wax the very slight softening or melting during momentary contact will facilitate the withdrawal of the punches and will not soften or melt the wax enough to injure the impression.

The invention consists in novel combinations of parts hereinabove briefly referred to and hereinafter described, and pointed out in the claims.

In the accompanying drawings, Figure 1 is a sectional elevation of a machine embodying my invention. Fig. 2 is a plan thereof. Fig. 3 is a side elevation looking in the opposite direction from the point of view in Fig. 1. Fig. 4 is a horizontal section, upon a larger scale, of certain parts of the machine upon about the plane indicated by the dotted line $x x$, Fig. 1. Fig. 5 is a partly-sectional elevation, upon a larger scale than the general figures, of one of the keys and a portion of the connections through which it transmits motion to a type-carrying arm. Fig. 6 is an edge view of a sheave comprised in such connections and a side view of which is included in Fig. 5. Figs. 7 and 8 are respectively a side view and an edge view of a sheave, which is also comprised in the line of connections extending from each key to its corresponding type-carrying arm. Figs. 9 and 10 are side views of two plates, a number of which are employed for properly spacing and separating the type-carrying arms. Fig. 11 is a sectional view, upon a larger scale than Fig. 1, of certain parts, whereby the matrix-table is moved and supported, said table being represented as hollow in Fig. 11; and Fig. 12 is a sectional view, upon a larger scale, of one of the type-punches or types and an end por-

tion of the arm which carries it. Fig. 13 is a view on an enlarged scale, showing a detail of a certain portion of the machine in perspective. Fig. 14 is a view on an enlarged scale of a certain block or piece for receiving a type-punch.

Similar letters of reference designate corresponding parts in all the figures.

The frame or case which supports the operating parts of my machine and which conceals them, so far as practicable, from dust and dirt, may be of any suitable construction. As here represented, it comprises a base-plate A, a rear casing, which is of segmental form, as shown in Fig. 2, and which comprises a lower portion A' and an upper portion A² and an inclined key board or plate A³, immediately above which these several keys, each bearing upon it a letter or symbol, are presented.

Q represents a copy-holder.

B designates type-carrying arms, a series of which is arranged side by side in a bank or group, segmental in plan view. This bank or group of arms forms a segment of a circle, as shown in Fig. 2 and also in Fig. 4. Each arm B carries at its free end a type-punch or a stem b , having upon its lower end, in relief, a letter or sign. At the opposite end these arms B are formed with approximately circular or disk-like body portions b' , and they are supported by pivots b^2 .

In order to properly space and hold the pivoted arms B accurately in position, I employ two series of plates B' B², which may be of the forms represented in Figs. 9 and 10. The arms B throughout their area are preferably of uniform thickness, and their segmental arrangement in the arc of a circle is secured by making the plates B', which are interposed between the body portions b' of the arms, wedge-shaped in their transverse section, as shown in Fig. 4. The arms B are pivoted in the plates B', and, as here represented, the pivots consist of circular hubs b^2 on opposite sides of the arms B, supported in corresponding recesses or depressions b^3 in opposite faces of the wedge-shaped plates B'. The plates B² are of substantially uniform thickness throughout and of about the same thickness, or either a very trifle thicker than the arms B or are made so by paper packing,

and when the plates B^2 are secured between the plates B' and the latter are held closely side by side the arms B will have the necessary clearance between the plates B' to give them freedom for movement on their pivots b^2 , and will also be held with sufficient snugness to prevent wobbling on their pivots. The form of the plates $B'B^2$ is clearly shown in Figs. 9 and 10, and the form or outline of the plates B^2 is clearly shown in Fig. 1. These several plates may be held in place by means of a hooked tongue or finger b^4 on the rear edge of each engaging a groove b^5 of corresponding hooked form between the two casing portions $A'A^2$, as is best shown in Fig. 1. The several plates $B'B^2$ and the arms B may be formed from sheet metal by suitable dies, and the end portion of the arms B must be thick enough laterally to receive through them the type-stems b , and may be bored to receive the stem, as shown in Fig. 12. Below the several arms B are arranged sheaves B^3 , which should be about the same thickness as the arms, and which are connected with the body portions b' of the arms by connecting rods or links b^6 , which are preferably of peculiar form, as shown in Fig. 1.

In the example of my invention here represented, the sheaves B^3 are each connected with a corresponding arm B by a pair of rods or links b^6 lying closely upon opposite sides of the arm B , as shown in Fig. 4, and pivotally connected at b^7 with the arm and at b^8 with the sheave B^3 . I have here represented on the plates B^2 upper shoulders b^9 , and on the arms B are corresponding shoulders b^{10} , which, when the arms swing upward on their pivots b^2 , abut against the shoulders or edge portions b^9 and so limit the upward movement of said arms. The plates B^2 project considerably forward between the plates B' , and the pair of connecting rods or links b^6 , which apply to each arm B lie upon opposite sides of the body portion b' of said arm and of the projecting portion of the corresponding plate B^2 , and are thus guided in their movements. The plates B' , which come between the arms B and their sheaves B^3 , may have adjacent to the pivots of the arms and sheaves, arc-shaped edges b^{11} b^{12} , as is shown in Fig. 9, and the rods or links b^6 may have corresponding arcs b^{13} b^{14} , the former of which bears against the arc-shaped surface b^{11} of the plate B' when the arm B is raised, and the latter of which b^{14} bears against the arc-shaped surface b^{12} of said plate when the arm B is lowered.

I will now describe the keys and the connections through which, by the depression of the keys, the arms B are swung downward in the direction of the arrow shown in Fig. 1, to cause their type-punches b to strike the matrix, hereinafter described.

C designates vertical push-rods, which work through a plate or board A^3 and are surmounted by buttons or finger-pieces c , each bearing a letter or symbol. On each rod may

be a collar c' , which, when the rod lifts, strikes against a cushion of india-rubber or other suitable material c^2 , and beneath the button or head c may be a corresponding cushion c^3 , to stop the rod without shock in its downward movement. Each rod C at its lower end is connected with a sheave C' , which constitutes in effect a lever, and from this sheave leads a wire or analogous flexible connection c^4 . The edge of the sheave may be grooved to receive the wire, as represented in Fig. 6, and the wire may be connected with a small drum or rotary pin c^5 , journaled in the sheave C' and provided at the side of the sheave with a ratchet-wheel c^6 , in engagement with which is a spring-pawl c^7 . By turning this drum and wheel c^5 c^6 in the direction of the arrow thereon (shown in Fig. 5) slack in the wire c^4 may be taken up and a tension maintained by the pawl c^7 . Upon the sheave C' may be cheek-pieces c^8 , between which works the lower flattened portion of the rod C , which is pivoted to the sheave at c^9 . On the inner side of this flattened lower portion of the rod is an arc-shaped recess or edge c^{10} , which, when the rod is depressed, as shown in the representation of one of the rods, Fig. 1, bears against the circular edge of the sheave C' , and this limits the downward movement. The arc-shaped curves or recesses c^{10} in the rods C and b^{13} b^{14} and in the rods b^6 are also important, as they provide for connecting the said rods to move about equally above and below horizontal planes through the pivots of the parts on which they act and avoid the necessity of making the sheaves $C'B^3$ with arms having a great projection from the center for the attachment of said rods.

As Fig. 1 is upon too small a scale to show the ratchet-and-pawl connections and tightening devices for the wires c^4 , I have illustrated them in Figs. 5 and 6. From its sheave C' the wire c^4 passes onto a sheave s , thence under a sheave or small wheel d , and thence to a sheave or oscillating disk or part d' , which constitutes, in effect, a bell-crank lever, and from this latter sheave d' the wire passes directly to and partly around the sheave B^3 and is attached thereto. The several sheaves d' may be supported in bearings depending from a cap-plate D , which may be of segmental form, and the sheaves are arranged so that the wires c^4 in passing to the several sheaves B^3 will not interfere with each other.

An advantageous construction for the sheaves d' is shown in Figs. 7 and 8. Each sheave may be pivoted in its hanger at d^2 , and has a segmental projection d^3 of larger radius than the body of the sheave and also a hole d^4 , through which the wire c^4 may pass. The edge of the portion of the sheave of small diameter is grooved, as shown in Figs. 7 and 8, and the outer edge of the segmental projection d^3 is also grooved, and the wire leading upward from the sheave d enters the grooved periphery of the portion of the sheave d' , which is of smaller radius, thence passes

through the hole or perforation d^4 , and thence over the edge of the sheave portion d^3 , which is of larger radius, and thence to the top of the sheave B^3 . The sheave d^4 , by reason of its peculiar form, constitutes, in effect, a bell-crank lever having arms of different length, the longer arm being connected with the sheave B^3 and the shorter arm having connected with it the portion of wire leading to the key, and by this construction the requisite movement for the type-carrying arm B may be obtained by a comparatively slight movement of the push-rod C . By depressing any one of the push-rods C a draft will be produced upon the wire c^4 , the several sheaves d^4 and the sheave B^3 will be turned in the direction of the arrow placed thereon in Fig. 1, a downward pull upon the rods or links b^6 will be exerted, and a type-carrying arm B will be swung downward in the direction of the arrow shown in Fig. 1. After the finger is removed from the key, which is at the head of the push-rod C , the arm B will be raised by a spring, which may consist simply of an elastic endless band d^5 , applied to a hook d^6 upon the sheave B^3 , and a fixed hook d^7 . The several hooks d^7 , on which are placed the spring-bands d^5 , may be secured in a cap-plate D' , covering an opening in the bed-plate A , through which access may be had to these springs and adjacent parts when said cap-plate is removed.

Having described how the type-punches, which are to form intaglio impressions in the matrix, are operated, I will now describe how the matrix may be supported and moved so as to secure the desired spacing between the several letters in a line of matter and between the several lines in a column.

Extending transversely across the machine is a channel or guideway E , in which slides a frame E' , here represented as made trough-like in its transverse section and having flanges e at the top, which fit in rabbets e' , formed in the slideway E . The slideway E has at its ends abutments or end portions E^2 E^3 , and the sliding frame E' likewise has end portions or abutments E^4 E^5 . Within the sliding frame E' , and extending lengthwise thereof, is a cylinder or roll F and other rolls f , as best shown in Fig. 11. Around the cylinder F , and also in proper direction around the rolls f , is passed an endless apron or belt f' , and the arrangement of cylinder and rolls shown give the belt at its upper part a horizontal portion, which supports a matrix-table F' , on which are placed the layer or layers of plastic material f^2 , which form a matrix of the desired thickness. The table may be held between two strips o on the belt. This table F' , I have shown solid in Fig. 1, owing to the small scale of that figure; but in Fig. 11 I have represented it as hollow and as provided with an inlet-opening f^3 for steam or heated air, in order that the matrix f^2 may be subjected to heat and the clearness of its intaglio impressions be increased. The width

of the matrix f^2 and its supporting-table F' , as shown in Figs. 1 and 11, should be sufficient to receive the length of the line of printed matter, and the length of this table (shown in Fig. 2) should correspond to the length of a column or page of printed matter.

The cylinder or large roll F has at its end a shaft F^2 , which may be polygonal in its transverse section, and which is free to slide lengthwise in a corresponding central aperture in the collar e^2 , journaled in the end piece E^3 of the slideway E , and the exterior of said collar being cylindrical the collar turns with and supports the prolongation F^2 , and through it the cylinder F . To the polygonal shaft are also fitted a gear-wheel e^3 and a sheave e^4 . This gear-wheel and sheave are held in the end piece E^3 against movement with the shaft F^2 in a direction lengthwise thereof; but they are locked to the shaft by the form of the shaft, and the openings in them receive the shaft, so that any turning movement of the gear-wheel e^3 or sheave e^4 will produce a corresponding movement of the shaft F^2 and the cylinder F , and will effect the travel of the apron f' and the sidewise movement of the matrix-table F' .

With the gear-wheel e^3 engages a gear-wheel e^5 , mounted upon a shaft, upon which is also secured a gear-wheel e^{10} . The latter engages a gear wheel or screw e^6 , which is upon a horizontal shaft e^7 , and has at its front end a button or head e^8 , whereby it may be turned. Applied to the sheave e^4 , by a cord or flexible connection e^9 , is a weight e^{10} , as shown in Fig. 3, and this weight exerts a constant tendency to turn the shaft F^2 and the cylinder F in one direction, but are prevented from effecting that result by the engagement of the wheel e^{10} with the worm e^6 . The worm-shaft e^7 is in a pivoted bearing or hub e^{11} , which enables it to be tilted so as to disengage its worm from the wheel e^6 .

In my machine I prefer to arrange the several keys, each of which is marked with a letter or symbol and through which the operation of the type-carrying arms B is effected, in the same position relatively to each other that the several cells for the type are arranged in relation to each other in a compositor's case, and these keys are worked by the operator with his right hand, while he operates the worm-shaft e^7 step by step with his left hand. By the described arrangement of the keys all the education of the compositor will be utilized or rendered available to enable him to do more rapid work on my machine than could a person unfamiliar with type-setting, for to operate the several keys he has only to move his right hand in the same directions that he would to take corresponding type from a compositor's case, and this he does intuitively. After the depression of each key to form the intaglio impression of a type-punch in the matrix f^2 the operator with his left hand turns the worm-shaft e^7 a small fraction of a turn, and through the gear just de-

scribed moves the matrix-table F' widthwise a distance equal to the space occupied by the last impressed letter. As soon as a line has been completed across the matrix f^2 the worm-shaft e^7 is swung on the pivot e^{11} to lift the worm e^6 out of engagement with the worm-wheel e^5 , and the weight e^{10} returns the table F' , after which the shaft e^7 is swung in a reverse direction, by which movement the worm e^6 is lowered into engagement with the wheel e^5 . The weight e^{10} is connected to the cylinder F , which cylinder is in turn connected to the screw-shaft f^{3*} . When the shaft F^2 is rotated by the weight e^{10} upon the turning of the shaft e^7 , the shaft f^{3*} will, by its engagement with the nut f^5 , thus cause a widthwise movement of the matrix-table. The worm-shaft e^7 , through gear-wheels e^{12} e^{13} , operates an index-finger e^{14} upon a dial e^{15} at the front of the machine, and this dial enables the operator to turn the worm a distance to produce the exact movement of the table F' necessary to give the variable space required for the several letters and intermediate vacancies.

To provide for raising the end of the shaft e^7 without interference from the wheels e^{12} , the end of said shaft may drop into a coupling e^* , by which it is connected with a short shaft o , on which the lower wheel e^{12} is secured, and which is journaled in a bearing o' , as best shown in Fig. 3.

At the end of the sliding frame E' , opposite the shaft F^2 , is a screw f^{3*} , provided with a crank-handle f^4 , whereby it may be turned, and fitting a nut f^5 in the end piece E^2 of the slideway E . The end of the cylinder F , which is adjacent to the screw, has a collar f^6 , and the adjacent end of the screw has a collar f^7 , both of which fit in a suitable circular or semi-circular seat f^8 , provided for them in the end piece E^4 of the sliding frame E' , and consequently the cylinder and the screw are held against endwise movement. The top of the nut f^5 , to which the screw is fitted, may be hinged, so that when it is swung upward the screw f^{3*} may be lifted out of engagement with its thread.

After the operator has formed one line of impressions across the matrix f^2 , it is necessary to move the table F' and the matrix not only laterally but also lengthwise, a distance equal to an interlineal space and a line, and this is effected by the operator turning the screw f^{3*} the required distance. After the matrix is completed and the sliding frame E' has been moved lengthwise step by step to as great a distance as is required by the length of the matrix the screw may be disengaged from the nut f^5 and drawn directly endwise, thereby shifting the sliding frame E' and the apron f' and table F' lengthwise for any desired distance. This avoids the necessity of turning the screw backward in order to return the table F' to a receiving position after the matrix has been formed and before operating upon a fresh body of plastic material to produce a second matrix.

The slideway E has at its top a cross-piece or bridge G , in which is set a removable or renewable socket-piece h , and this socket-piece has a single aperture h' , which is upwardly flaring or funnel-shaped, corresponding in size at its lower end to the heads of the type-punches. Above the piece h is placed a cushion h^2 , against which the end of the arm B strikes as it descends in operation, and which deadens the shock produced by the impact of the arm. The block or piece h is fitted to a funnel-shaped seat h^3 in the bridge G , and may be removed at any time and another substituted.

One construction of the type-punch and the end portion of the arm in which it is secured is best shown in Fig. 12. The lower end of the stem b , which carries the type-punch, may be square, as shown at i , and provided with a shoulder i' , and above the arm B such stem is provided with a nut i^2 . By loosening the nut i^2 , and then lowering the arm B so that its type-punch enters the square aperture h' in the socket-piece h , the stem will be turned in the arm B to bring its operating-face at just the angle desired in order to strike properly on the matrix, and by then tightening the nut i^2 the type-punch will be fixed in position in the arm B .

I have before stated that the matrix-table F' may be hollow, so as to provide for heating it from within and in order to heat the matrix and effect clean-cut impressions of the type-punches. To this same end I also prefer to arrange a heater adjacent to the position which the type-punches b occupy, as shown in Fig. 1, when the arms B carrying them are raised and are at rest in their operative position. The upper portion A^2 of the casing may be made hollow, so as to constitute a steam-chamber j , having a recess j' , into which the type-punches enter when the arms B are raised, and which may have an inlet-pipe j^2 for steam and an outlet-pipe j^3 for the water of condensation and steam. During the operation of the machine each of the type-carrying arms is for most of the time in a raised and inoperative position, as shown in Fig. 1, and the employment of this heating-chamber provides for maintaining the type-punches constantly hot. The adjusting of spaces between words for the purpose of properly filling each line is also provided for by the use of the button e^8 and by the dial indicating a full line in each of its circuits.

What I claim as my invention, and desire to secure by Letters Patent, is—

1. The combination, with the matrix-table and the series of type-punches and punch-carrying arms movable toward the matrix for impressing it and away from the matrix to a position of rest, of a heater arranged adjacent to the position occupied by the punches when at rest.

2. The combination, with a series of pivoted punch-bearing arms and keys and connections, substantially as described, through

which they are operated, the operation of the keys both furnishing power and regulating the selection of the punches, of a matrix table and frame provided with rollers and movable in the direction of its length, a belt passing around the rollers and directly supporting the table, and a gearing for moving said frame lengthwise and for imparting a step-by-step motion to the belt, substantially as specified.

3. The combination, with the pivoted arms B and the keys and connections, substantially as described, for operating them, of the sliding frame E', the rollers journaled therein and one of which F has a shaft prolongation, a gear-wheel in which said shaft slides, but which is locked to the shaft for turning it, a weight for turning said shaft and its attached roller in one direction and a worm for turning it in the other direction and which is mounted to move transversely out of engagement with the wheel on which it operates, a matrix-table and an endless belt supporting it and passing around said rollers, and a screw for moving said frame lengthwise of the rollers, substantially as herein described.

4. The combination, with a movable matrix-table and pivoted punch-carrying arms for operating on the matrix, of vertical push-rods, each representing a letter or symbol, flexible connections and sheaves whereby motion is transmitted from said push-rods to said arms, and adjustable tension devices on certain of the sheaves, whereby slack in the connections may be taken up, substantially as herein described.

5. The combination, with a movable matrix-table and pivoted punch-carrying arms for operating on the matrix, of sheaves C', and push-rods C, pivoted thereto and having the arc-shaped recess c¹⁰, which provides for pivoting them close to the peripheries of the sheaves, and other sheaves and flexible connections c⁴, through which the said arms are operated from the rods and sheaves C C', substantially as herein described.

6. The combination, with a movable matrix-table and a series of keys, each representing a letter or symbol, and flexible connections and sheaves through which the arms are operated by the keys, certain of the sheaves d' having peripheral arcs of different radii, over which the flexible connections are passed and which constitute, in effect, bell-crank le-

vers having arms of unequal length, substantially as herein described.

7. The combination, with a movable matrix-table and pivoted punch-carrying arms, of the plates B² in the same vertical planes with the said arms and forming stops to the arms, and the wedge-shaped plates B', interposed between the arms, and keys and flexible connections for operating the arms, substantially as herein described.

8. The combination, with a movable matrix-table, a series of pivoted punch-carrying arms, and a casing constructed with a retaining-groove b⁵, of the plates B' B², arranged alternately between and in the same planes with the arms and formed with tongues b⁴, which are retained in said groove, substantially as herein described.

9. The combination, with a matrix-table and the pivoted punch-carrying arms B, having circular body portions, of the sheaves B³, the plates B' B², for spacing and supporting the arms, and the rods b⁶, connecting the sheaves and arms and guided in their movements by said plates, and keys and connections for operating said sheaves and arms, substantially as herein described.

10. The combination, with a movable matrix-table and the pivoted arms B, of punches b, each having a rectangular head and a stem which may be turned in the arm, and a nut for clamping the stem in place after adjustment, a funnel-shaped socket-piece or mouth terminating in a rectangular aperture, through which the punches reach the matrix and which serves to accurately and automatically adjust the punches to the proper positions when loose in their arms, and keys and connections, substantially as described, for operating said arms, substantially as herein set forth.

11. The combination, with a movable matrix-table and pivoted punch-carrying arms for operating on a matrix supported on the table, of keys, each representing a letter or symbol and arranged similarly to the type in a compositor's case, and flexible connections for operating the said arms by the keys, substantially as herein described.

F. M. F. CAZIN.

Witnesses:

C. HALL,
FREDK. HAYNES.