

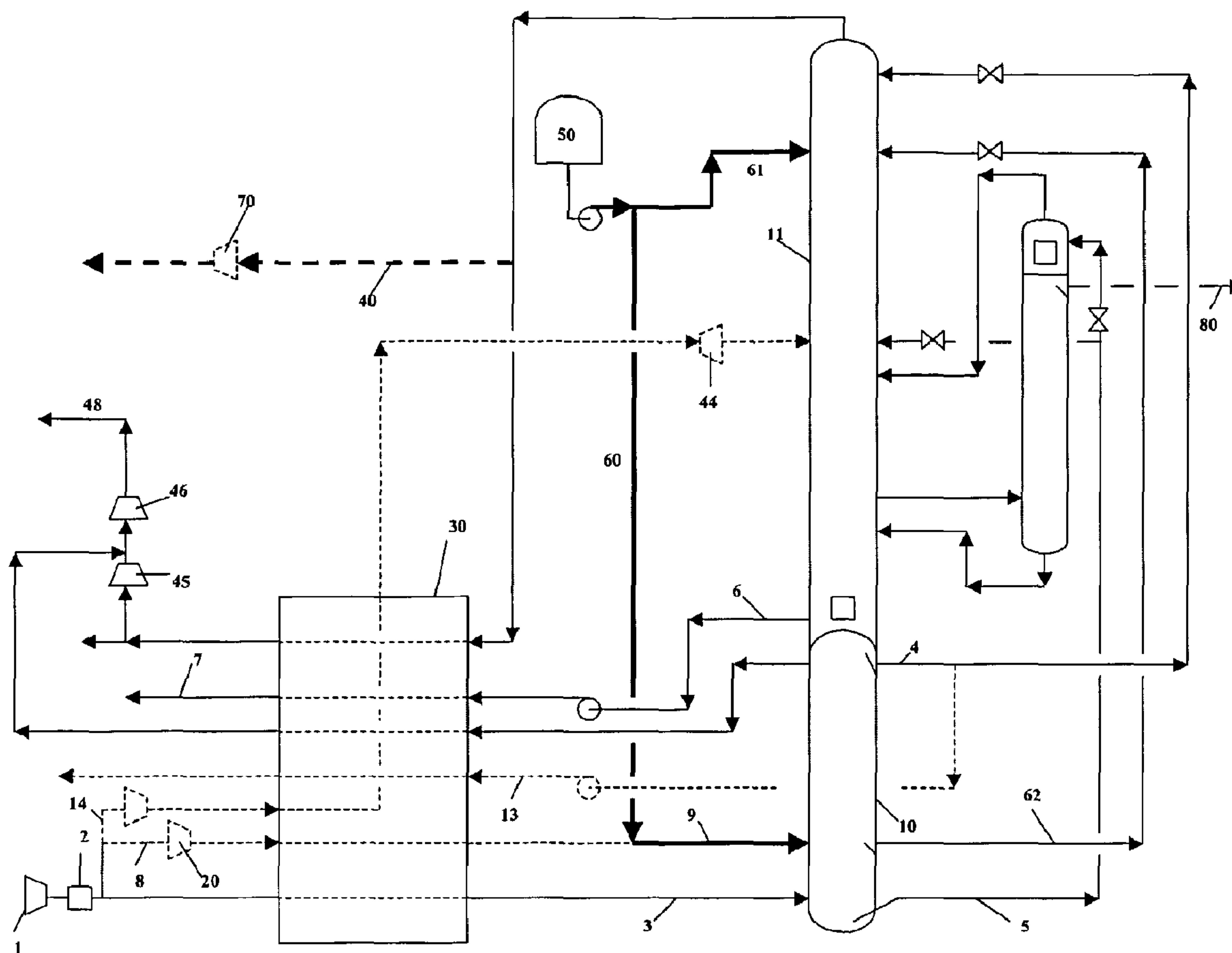

(86) Date de dépôt PCT/PCT Filing Date: 2004/10/18
 (87) Date publication PCT/PCT Publication Date: 2005/07/14
 (45) Date de délivrance/Issue Date: 2011/05/03
 (85) Entrée phase nationale/National Entry: 2006/06/21
 (86) N° demande PCT/PCT Application No.: IB 2004/003405
 (87) N° publication PCT/PCT Publication No.: 2005/064252
 (30) Priorités/Priorities: 2003/12/23 (US60/532,219);
 2004/03/11 (US10/798,068); 2004/07/27 (US10/899,688)

(51) Cl.Int./Int.Cl. *F25J 3/04* (2006.01)
 (72) Inventeurs/Inventors:
 BRUGEROLLE, JEAN-RENAUD, FR;
 HA, BAO, US
 (73) Propriétaire/Owner:
 L'AIR LIQUIDE, SOCIETE ANONYME POUR L'ETUDE
 ET L'EXPLOITATION DES PROCEDES GEORGES
 CLAUDE, FR
 (74) Agent: LEDGLEY LAW

(54) Titre : PROCEDE ET DISPOSITIF DE SEPARATION D'AIR CRYOGENE
 (54) Title: CRYOGENIC AIR SEPARATION PROCESS AND APPARATUS



(57) Abrégé/Abstract:

A low temperature air separation process and apparatus for producing pressurized gaseous product in an air separation unit using a system of distillation columns (10,11) which include cooling a compressed air stream in a heat exchange line (30) to form a

(57) **Abrégé(suite)/Abstract(continued):**

compressed cooled air stream, sending at least part of the compressed, cooled air stream to a column of the system, liquefying (60) a process stream (47) to form a first liquid product, storing at least part of the first liquid product in a storage tank (50), sending at least part of the above first liquid product from the storage tank to the air separation unit as one of the feeds (60,61), extracting at least one second liquid product stream from a column of the column system and pressurizing the at least one second liquid product stream (6), vaporizing the above pressurized second liquid product stream to form pressurized gaseous product in the heat exchange line and extracting a cold gas (40)(without warming it completely in the heat exchange line.

(12) INTERNATIONAL APPLICATION PUBLISHED UNDER THE PATENT COOPERATION TREATY (PCT)

(19) World Intellectual Property
Organization
International Bureau



(43) International Publication Date
14 July 2005 (14.07.2005)

PCT

(10) International Publication Number
WO 2005/064252 A1

- (51) International Patent Classification⁷: **F25J 3/04**
- (21) International Application Number:
PCT/IB2004/003405
- (22) International Filing Date: 18 October 2004 (18.10.2004)
- (25) Filing Language: English
- (26) Publication Language: English
- (30) Priority Data:
60/532,219 23 December 2003 (23.12.2003) US
10/798,068 11 March 2004 (11.03.2004) US
10/899,688 27 July 2004 (27.07.2004) US
- (71) Applicant (for all designated States except US): **L'AIR LIQUIDE - SOCIETE ANONYME A DIRECTOIRE ET CONSEIL DE SURVEILLANCE POUR L'ETUDE ET L'EXPLOITATION DES PROCEDES GEORGES CLAUSE** [FR/FR]; 75, quai d'Orsay, F-75321 Paris Cedex 07 (FR).
- (72) Inventors: **BRUGEROLLE, Jean-Renaud**; 9, rue des Bauches, F-75016 Paris (FR). **HA, Bao**; 208 Dandelion Lane, San Ramon, CA 94583 (US).
- (81) Designated States (unless otherwise indicated, for every kind of national protection available): AE, AG, AL, AM, AT, AU, AZ, BA, BB, BG, BR, BW, BY, BZ, CA, CH, CN, CO, CR, CU, CZ, DE, DK, DM, DZ, EC, EE, EG, ES, FI, GB, GD, GE, GH, GM, HR, HU, ID, IL, IN, IS, JP, KE, KG, KP, KR, KZ, LC, LK, LR, LS, LT, LU, LV, MA, MD, MG, MK, MN, MW, MX, MZ, NA, NI, NO, NZ, OM, PG, PH, PL, PT, RO, RU, SC, SD, SE, SG, SK, SL, SY, TJ, TM, TN, TR, TT, TZ, UA, UG, US, UZ, VC, VN, YU, ZA, ZM, ZW.
- (84) Designated States (unless otherwise indicated, for every kind of regional protection available): ARIPO (BW, GH, GM, KE, LS, MW, MZ, NA, SD, SL, SZ, TZ, UG, ZM, ZW), Eurasian (AM, AZ, BY, KG, KZ, MD, RU, TJ, TM), European (AT, BE, BG, CH, CY, CZ, DE, DK, EE, ES, FI, FR, GB, GR, HU, IE, IT, LU, MC, NL, PL, PT, RO, SE, SI, SK, TR), OAPI (BF, BJ, CF, CG, CI, CM, GA, GN, GQ, GW, ML, MR, NE, SN, TD, TG).

Declaration under Rule 4.17:

- as to the applicant's entitlement to claim the priority of the earlier application (Rule 4.17(iii)) for the following designations AE, AG, AL, AM, AT, AU, AZ, BA, BB, BG, BR, BW, BY, BZ, CA, CH, CN, CO, CR, CU, CZ, DE, DK, DM, DZ,

[Continued on next page]

(54) Title: CRYOGENIC AIR SEPARATION PROCESS AND APPARATUS

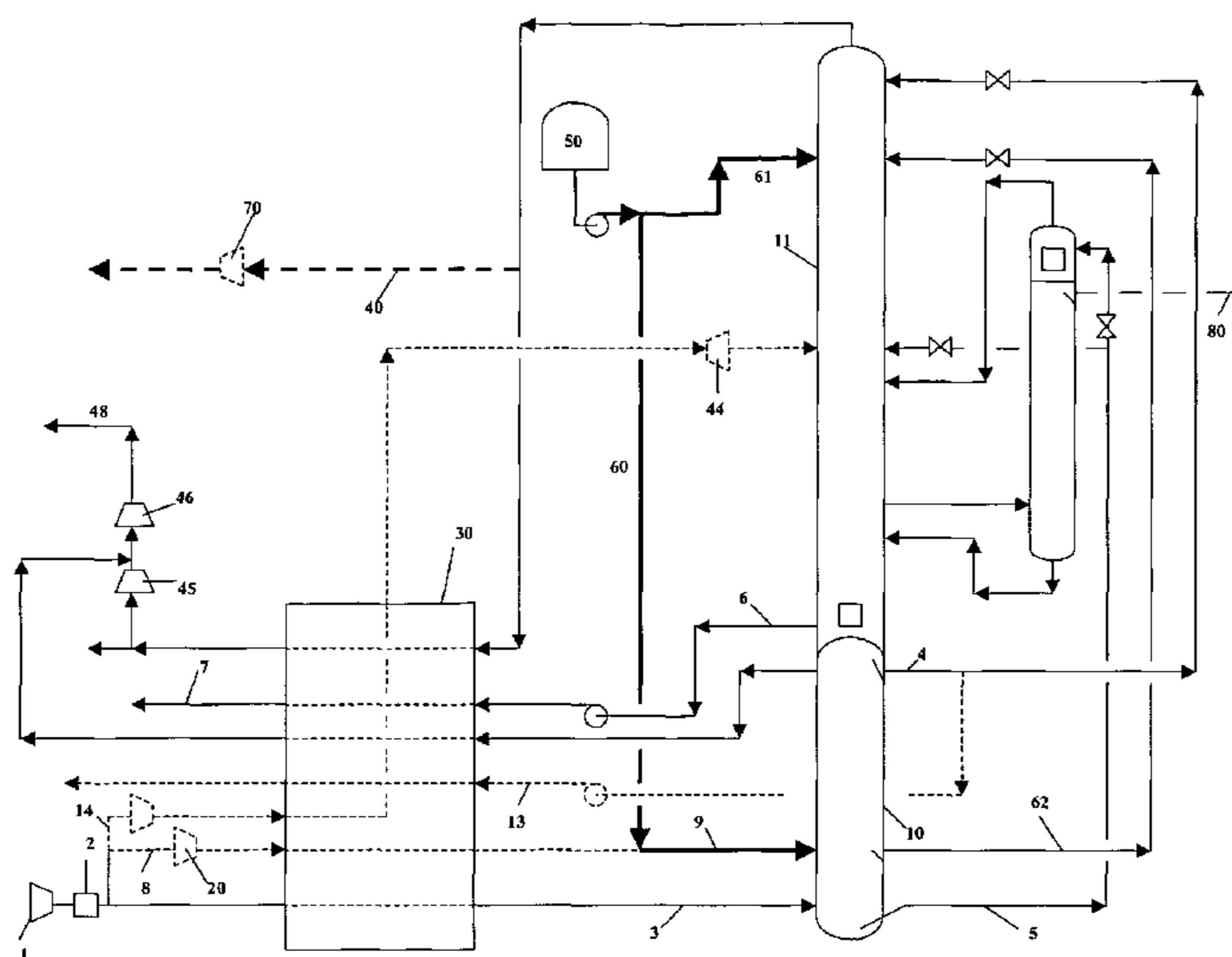

(57) Abstract: A low temperature air separation process and apparatus for producing pressurized gaseous product in an air separation unit using a system of distillation columns (10,11) which include cooling a compressed air stream in a heat exchange line (30) to form a compressed cooled air stream, sending at least part of the compressed, cooled air stream to a column of the system, liquefying (60) a process stream (47) to form a first liquid product, storing at least part of the first liquid product in a storage tank (50), sending at least part of the above first liquid product from the storage tank to the air separation unit as one of the feeds (60,61), extracting at least one second liquid product stream from a column of the column system and pressurizing the at least one second liquid product stream (6), vaporizing the above pressurized second liquid product stream to form pressurized gaseous product in the heat exchange line and extracting a cold gas (40)(without warming it completely in the heat exchange line.

WO 2005/064252 A1

WO 2005/064252 A1

EC, EE, EG, ES, FI, GB, GD, GE, GH, GM, HR, HU, ID, IL, IN, IS, JP, KE, KG, KP, KR, KZ, LC, LK, LR, LS, LT, LU, LV, MA, MD, MG, MK, MN, MW, MX, MZ, NA, NI, NO, NZ, OM, PG, PH, PL, PT, RO, RU, SC, SD, SE, SG, SK, SL, SY, TJ, TM, TN, TR, TT, TZ, UA, UG, UZ, VC, VN, YU, ZA, ZM, ZW, ARIPO patent (BW, GH, GM, KE, LS, MW, MZ, NA, SD, SL, SZ, TZ, UG, ZM, ZW), Eurasian patent (AM, AZ, BY, KG, KZ, MD, RU, TJ, TM), European patent (AT, BE, BG, CH, CY, CZ, DE, DK, EE, ES, FI, FR, GB, GR, HU, IE,

IT, LU, MC, NL, PL, PT, RO, SE, SI, SK, TR), OAPI patent (BF, BJ, CF, CG, CI, CM, GA, GN, GQ, GW, ML, MR, NE, SN, TD, TG)

Published:

— with international search report

For two-letter codes and other abbreviations, refer to the "Guidance Notes on Codes and Abbreviations" appearing at the beginning of each regular issue of the PCT Gazette.

CRYOGENIC AIR SEPARATION PROCESS AND APPARATUS

5

Field of Invention

This invention relates to an air separation process and associated equipment.

Background of the Invention

10 Air separation is a very power intensive technology, consuming thousands of kilowatts or several megawatts of electric power to produce large quantities of industrial gases for tonnage applications such as chemicals, refineries, steel mills, etc.

15 A typical liquid pumped process is illustrated in Figure 1. In this type of process, atmospheric air is compressed by a Main Air Compressor (MAC) 1 to a pressure of about 6 bar absolute, it is then purified in an adsorber system 2 to remove impurities such as moisture and carbon dioxide that can freeze at cryogenic temperature to yield a purified feed air. A portion 3 of this purified feed air is then cooled to near its
20 dew point in heat exchanger 30 and is introduced into a high pressure column 10 of a double column system in gaseous form for distillation. Nitrogen rich liquid 4 is extracted at the top of this high pressure column and a portion is sent to the top of the low pressure column 11 as a reflux stream. The oxygen-enriched liquid stream 5 at the bottom of the high pressure column is also sent to the low pressure column as
25 feed. These liquids 4 and 5 are subcooled before expansion against cold gases in subcoolers not shown in the figure for the sake of simplicity. An oxygen liquid 6 is extracted from the bottom of the low pressure column 11, pressurized by pump to a required pressure then vaporized in the exchanger 30 to form the gaseous oxygen product 7. Another portion 8 of the purified feed air is further compressed in a
30 Booster Air Compressor (BAC) 20 to high pressure for condensation in the exchanger 30 against the vaporizing oxygen enriched stream. Depending upon the pressure of the oxygen rich product, the boosted air pressure can be around 65 bar or sometimes over 80 bar. The condensed boosted air 9 is also sent to the column system as feed for the distillation, for example to the high pressure column. Part of
35 the liquid air may be removed from the high pressure column and sent to the low

pressure column following subcooling and expansion. It is also possible to extract nitrogen rich liquid from the top of the high pressure column then pump it to high pressure (stream 13) and vaporize it in the exchanger in the same way as with oxygen liquid. A small portion of the feed air (stream 14) is further compressed and expanded into the column 11 to provide the refrigeration of the unit. Optionally alternative or additional means of providing refrigeration may be used, such as Claude expanders or nitrogen expanders.

Waste nitrogen is removed from the top of the low pressure column and warms in exchanger 30. Argon is produced using a standard argon column whose top condenser is cooled with oxygen enriched liquid 5.

A typical 3,000 ton/day oxygen plant producing gaseous oxygen under pressure for industrial uses can consume typically about 50 MW. A network of oxygen plants for pipeline operation would require a power supply capable of providing several hundreds megawatts of electric power. In fact, the electric power is the main operating cost of an air separation plant since its raw material or feedstock is atmospheric air and is essentially free. Electric power is used to drive compressors for air or products compression. Therefore, power consumption or process efficiency is one of the most important factors in the design and operation of an air separation unit (ASU). Power rate, usually expressed in \$/kWh, is not constant during the day but varies widely depending upon the peaks or off-peaks. It is well known that during the day the power rate is the highest when there is strong demand – or peak period – and the lowest during the low demand – or off-peak period. Utility companies tend to offer significant cost reduction if an industrial power user can cut back its power consumption during peaks. Therefore, the companies operating air separation units always have strong incentives to adjust the operating conditions of the plants to track the power demand so that to lower the utility cost. It is clear that a solution is needed to provide an economical answer to this variable power rate issue.

It is useful to note that the periods when the power peaks take place may be totally different from the product demand peaks, for example, a warm weather would

generate a high power demand due to air conditioning equipment meanwhile the demand for products remains at normal level. In several locations, the peaks occur during the day time when the industrial output of manufacturing plants, the main users of industrial gases, is usually at the highest level and when combined with the high power usage of other activities would cause very high demand on the electric grid. This high power usage creates potential shortage and utility companies must allocate other sources of power supply causing temporary high power rate. Also, usually at night, the power demand is lower and the power is available abundantly such that the utility companies could lower the power rate to encourage usage and to keep the power generating plants operate efficiently at reduced load. The power rate at peaks can be twice or several times higher than the power rate for off-peaks.

In this application, the term "peak" describes the period when power rate is high and the term "off-peak" means the period when power rate is low.

For industrial power users, power rates are usually negotiated and defined in advance in power contracts. In addition to the daily variation of power rates, sometimes there are provisions or allowances for interruptible power supply: during periods of high power demand on the power grid, the utility companies can reduce the supply to those users with a relatively short advance notice, in return, the overall power rate offered can be significantly below the normal power rate. This kind of arrangement provides additional incentives for users to adapt their consumption in line with the network management of the power suppliers. Therefore, significant cost reduction can be achieved only if the plant equipment can perform such flexibility. Based on the power cost structure as set forth by the power contracts, the users can define predetermined threshold or thresholds of power rate to trigger the mechanism of power reduction:

- when power rate is above the predetermined threshold, the power usage is reduced to lower the cost.
- when power rate is below the predetermined threshold, the power usage is increased to normal level or even higher if desired.

A simple approach to address the problem of variable power rate is to lower the plant's power consumption during peaks while maintaining the product output in

order to satisfy the customer's need. However, the cryogenic process of air separation plants is not very flexible since it involves distillation columns and the product specifications require fairly high purities. Attempts to lower the plant output in a very short time or to increase the plant production quickly to meet product demand can have detrimental effects over plant stability and product integrity. Various patents have been written to suggest how to solve the difficulties associated with the variable product demand of a cryogenic plant.

US Patent 3,056,268 teaches the technique of storing oxygen and air under liquid form and vaporizing the liquids to produce gaseous products to satisfy the variable demand of the customer, such as at metallurgical plants. The liquid oxygen is vaporized when its demand is high. This vaporization is balanced by a condensation of liquid nitrogen via the main condenser of the double column air separation unit.

US Patent 4,529,425 teaches a similar technique to that of US Patent 3,056,268 to solve the problem of variable demand, but liquid nitrogen is used instead of liquid air.

US Patent 5,082,482 offers an alternative version of US Patent 3,056,268 by sending a constant flow of liquid oxygen into a container and withdrawing from it a variable flow of liquid oxygen to meet the requirement of variable demand of oxygen. Withdrawn liquid oxygen is vaporized in an exchanger by condensation of a corresponding flow of incoming air.

US Patent 5,084,081 teaches yet another method of US Patent 4,529,425 wherein another intermediate liquid, the oxygen enriched liquid, is used in addition to the traditional liquid oxygen and liquid nitrogen as the buffered products to address the variable demand. The use of enriched oxygen liquid allows stabilizing the argon column during the variable demand periods.

In still another approach to address the variable product demand, US Patent 5,666,823 teaches a technique to efficiently integrate the air separation unit with a high pressure combustion turbine. Air extracted from the combustion turbine during the periods of low product demand is fed to the air separation unit and a portion is

expanded to produce liquid. When product demand is high, less air is extracted from the combustion turbine and the liquid produced earlier is fed back to the system to satisfy the higher demand. The refrigeration supplied by the liquid is compensated by not running the expander for lack of extracted air from the
5 combustion turbine during the high product demand.

The above publications addressed the technical issues of the variable demand, especially the techniques used to maintain stability of the distillation columns during the time when the demand of the product varies widely. However, none of the
10 above directly address the aspect of potential savings and economy when adapting the air separation plants to the power rate structure of peak and off-peak periods to obtain cost reduction. Industry practice also does not resolve the technical problems associated with the adjustment of the air separation units during periods of high
15 power cost and with relatively unchanged product demand. In fact, these two aspects of the operation of air separation units are quite different by nature: one is governed by the customer's variable demand and the other is governed by variable power cost with relatively constant demand.

Therefore, there exists a need to come up with a configuration for air separation
20 plants permitting a reduction of the power consumption during peaks, while maintaining a supply of products to satisfy customer's demand. To make up for this reduction of power, additional power consumption can be arranged to take place during off-peak periods, at a much lower power rate. Significant savings on power
25 rate can therefore be achieved, since a portion of the products is being produced at a low power rate and supplied to the customers during periods of high power rate.

Summary of the Invention

This invention offers a technique to resolve the problems associated with the reduction of power consumption during peak periods, while still being capable of
30 maintaining the same product output, so that power cost savings can be achieved.

Key aspects include:

- a) liquefying a process stream in off-peak periods to produce a first liquid product;

- b) feeding the air separation unit with the produced first liquid product in peak periods;
- c) reducing air feed supplied by the air compressor to maintain the total amount of oxygen contained in the feed streams essentially the same;
- 5 d) withdrawing at least one product from the column system and raising its pressure by pumping, and then vaporizing, in a heat exchanger to form gaseous product;
- e) withdrawing a cold gas from the system at cryogenic temperature; and
- f) cryogenically compressing the produced cold gas to higher pressure
- 10 with a cold gas compressor.

In accordance with an aspect of the present invention, there is provided a low temperature air separation process for producing pressurized gaseous product in an air separation unit contained within a cold box using a system of distillation columns which comprises the following steps:

- 15 a. Cooling a compressed air stream in a heat exchange line to form a compressed cooled air stream
- b. Sending at least part of the compressed, cooled air stream to a column of the system
- c. In a first period of time, only if the electricity rate is below a predetermined
- 20 threshold, liquefying a process stream to form a first liquid product and storing at least part of this first liquid product
- d. In a second period of time, only if the electricity rate is above a predetermined threshold sending the above stored first liquid product to the air separation unit as one of the feeds
- 25 e. Pressurizing at least one second liquid product stream
- f. Vaporizing the above pressurized second liquid product stream in the heat exchange line to form pressurized gaseous product
- g. During the above second period of time, only if the electricity rate is above a predetermined threshold extracting a cold gas from the air separation
- 30 unit cold box at a temperature between -195°C and -20°C .

6a

In accordance with another aspect of the present invention, there is provided the process of the present invention wherein the pressurized gaseous product is oxygen product.

5 In accordance with another aspect of the present invention, there is provided the process of the present invention wherein the pressurized gaseous product is nitrogen product.

In accordance with another aspect of the present invention, there is provided the process of the present invention wherein the process stream of step c) contains any proportion of oxygen, nitrogen and argon.

10 In accordance with another aspect of the present invention, there is provided the process of the present invention wherein the process stream of step c) is at least one of pure nitrogen, air, oxygen containing at least 37 mol. % oxygen, oxygen containing at least 65 mol. % oxygen, oxygen containing at least 85 mol.% oxygen and oxygen containing at least 99.5 mol.%.

15 In accordance with another aspect of the present invention, there is provided the process of the present invention wherein the cold gas of step g) is chosen from the group comprising a nitrogen rich gas, pure nitrogen gas, air, a gas having a composition similar to air, an oxygen rich gas and pure oxygen product.

20 In accordance with another aspect of the present invention, there is provided the process of the present invention wherein the second liquid product of step e) is the same as the stored first liquid product of step c).

In accordance with another aspect of the present invention, there is provided the process of the present invention wherein at least a portion of the cold gas of step g) is heated and expanded in a hot expander to recover energy.

25 In accordance with another aspect of the present invention, there is provided the process of the present invention wherein at least a portion of the cold gas of step g) is injected into a gas turbine for energy recovery

30 In accordance with another aspect of the present invention, there is provided the process of the present invention wherein at least a portion of the cold gas of step g) is recycled back to the air separation unit.

6b

In accordance with another aspect of the present invention, there is provided the process of the present invention wherein the air separation unit supplies pressurized gaseous oxygen product to an IGCC facility

In accordance with another aspect of the present invention, there is provided the process of the present invention wherein the IGCC facility comprises a gas turbine further comprising the following steps:

- a. Extracting air from the gas turbine if the rate of electricity is below a predetermined threshold
- b. Feeding above extracted air to the air separation unit

In accordance with another aspect of the present invention, there is provided the process of the present invention comprising the step of injecting pressurized cold gas to the gas turbine if the rate of electricity is higher than a predetermined threshold.

In accordance with another aspect of the present invention, there is provided the process of the present invention wherein the refrigeration of vaporizing LNG is recovered to reduce the liquefaction cost of the first liquid product.

In accordance with another aspect of the present invention, there is provided the process of the present invention comprising reducing the flow of compressed air in the heat exchanger if the rate of electricity is above a predetermined threshold as compared to the amount of air cooled in the heat exchanger if the rate of electricity is below a predetermined threshold.

In accordance with another aspect of the present invention, there is provided the process of the present invention wherein the cold gas is removed from the air separation unit without warming it in the heat exchange line.

In accordance with another aspect of the present invention, there is provided the process of the present invention wherein the cold gas is removed from the air separation unit after being warmed partially in the heat exchange line.

In accordance with another aspect of the present invention, there is provided the process of the present invention wherein the cold gas is removed from the air

separation unit after being warmed by traversing the warm end of the heat exchange line only.

In accordance with another aspect of the present invention, there is a low temperature air separation process for producing pressurized gaseous product in an air separation unit using a system of distillation columns which comprises the following steps:

a) Cooling a compressed air stream in a heat exchange line to form a compressed cooled air stream

b) Sending at least part of the compressed, cooled air stream to a column of the system

c) In a first period of time, only if the electricity rate is below a predetermined threshold, liquefying a process stream to form a first liquid product and storing at least part of the first liquid product

d) In a second period of time, only if the electricity rate is above a

predetermined threshold sending the above stored first liquid product to the air separation unit as one of the feeds

e) Pressurizing at least one second liquid product stream

f) Vaporizing the above pressurized second liquid product stream to form pressurized gaseous product in the heat exchange line

g) During the above second period of time, only if the electricity rate is above a predetermined threshold extracting a cold gas from the air separation unit and compressing the cold gas in a compressor having an inlet temperature between -180°C and -50°C and an outlet temperature of at most -20°C to form a pressurized gas.

In accordance with another aspect of the present invention, there is provided the process of the present invention wherein the pressurized gaseous product is oxygen product.

In accordance with another aspect of the present invention, there is provided the process of the present invention wherein pressurized gaseous product is nitrogen product.

6d

In accordance with another aspect of the present invention, there is provided the process of the present invention wherein the process stream of step c) contains any proportion of oxygen, nitrogen and argon.

5 In accordance with another aspect of the present invention, there is provided the process of the present invention wherein the process stream of step c) is at least one of pure nitrogen, air, oxygen containing at least 37 mol. % oxygen, oxygen containing at least 65 mol. % oxygen, oxygen containing at least 85 mol.% oxygen and oxygen containing at least 99.5 mol.%.

10 In accordance with another aspect of the present invention, there is provided the process of the present invention wherein the cold gas of step g) is chosen from the group comprising a nitrogen rich gas, pure nitrogen, air, a gas having a composition similar to air, an oxygen rich gas and pure oxygen product.

15 In accordance with another aspect of the present invention, there is provided the process of the present invention wherein the cold gas is compressed to a pressure between 35 and 80 bars abs in the compressor.

In accordance with another aspect of the present invention, there is provided the process of the present invention wherein at least a portion of the pressurized gas is heated and expanded in a hot expander to recover energy.

20 In accordance with another aspect of the present invention, there is provided the process of the present invention wherein at least a portion of the pressurized gas is injected into a gas turbine for energy recovery.

In accordance with another aspect of the present invention, there is provided the process of the present invention wherein at least a portion of the pressurized gas is recycled back to the column system of the air separation unit

25 In accordance with another aspect of the present invention, there is provided the process of the present invention wherein the air separation unit supplies pressurized gaseous oxygen product to an IGCC facility.

30 In accordance with another aspect of the present invention, there is provided the process of the present invention wherein the IGCC facility comprises a gas turbine further comprising the following steps:

6e

a. Extracting air from the gas turbine if the rate of electricity is below a predetermined threshold

b. Feeding above extracted air to the air separation unit.

5 In accordance with another aspect of the present invention, there is provided the process of the present invention comprising the step of injecting the pressurized cold gas to the gas turbine if the rate of electricity is higher than a predetermined threshold.

In accordance with another aspect of the present invention, there is provided the process of the present invention further comprising the following steps:

10 a) Warming the pressurized gas in the heat exchange line

b) Cooling additional gas in the heat exchange line to form cold additional gas

c) Cryogenically compressing cold additional gas to higher pressure.

15 In accordance with another aspect of the present invention, there is provided the process of the present invention wherein both gases are compressed to between 10 and 20 bars abs.

In accordance with another aspect of the present invention, there is provided the process of the present invention wherein the refrigeration of vaporizing LNG is recovered to reduce the liquefaction cost of the first liquid product.

20 In accordance with another aspect of the present invention, there is provided the process of the present invention comprising reducing the flow of compressed air in the heat exchange line if the rate of electricity is above a predetermined threshold as compared to the amount of air cooled in the heat exchange line if the rate of electricity is below a predetermined threshold.

25 In accordance with another aspect of the present invention, there is provided the process of the present invention wherein the cold gas is removed from the air separation unit cold box without warming it in the heat exchange line.

30 In accordance with another aspect of the present invention, there is provided the process of the present invention wherein the cold gas is removed from the air separation unit cold box after being warmed partially in the heat exchange line.

In accordance with another aspect of the present invention, there is provided the process of the present invention wherein the cold gas is removed from the air separation unit cold box after being warmed by traversing the warm end of the heat exchange line only.

5 In accordance with another aspect of the present invention, there is provided the process of the present invention comprising the step of warming the pressurized gas in the heat exchange line.

In accordance with another aspect of the present invention, there is provided an air separation apparatus comprising

- 10 a) a system of distillation columns
b) a heat exchange line
c) a cold box containing at least the system of distillation columns and the heat exchange line
d) a conduit for sending feed air to the heat exchange line
15 e) a conduit for sending cooled feed air from the heat exchange line to the column system
f) means for sending a first liquid product to the column system
g) a conduit for removing a liquid from a column of the column system
h) a conduit for sending the liquid to the heat exchange line
20 i) a conduit for removing vaporized liquid from the heat exchange line and
j) a conduit for extracting a gas from a column of the system and for removing the gas from the air separation apparatus without warming the gas by traversing the heat exchange line in its entirety.

25 In accordance with another aspect of the present invention, there is provided the apparatus of the present invention comprising means for storing the first liquid product outside any column of the column system.

In accordance with another aspect of the present invention, there is provided the apparatus of the present invention comprising a gas compressor connected to the conduit for extracting gas.

In accordance with another aspect of the present invention, there is provided the apparatus of the present invention comprising an air compressor having an inlet and an outlet, the inlet of the air compressor being connected to a compressed air conduit at an intermediate point of the heat exchanger.

5 In accordance with another aspect of the present invention, there is provided the apparatus of the present invention comprising a gas turbine having an expander and a conduit for sending gas compressed in the cold gas compressor to a point upstream the expander.

10 In accordance with another aspect of the present invention, there is provided the apparatus of the present invention comprising a conduit for removing the gas from the air separation apparatus without warming the gas in the heat exchange line.

In accordance with another aspect of the present invention, there is provided the apparatus of the present invention comprising means for liquefying a gas to form the first liquid product.

15

Brief Description of the Drawings

For a further understanding of the nature and objects for the present invention, reference should be made to the following detailed description, taken in conjunction with the accompanying drawings, in which like elements are given the same or analogous reference numbers and wherein:

20

- Figure 1 illustrates the prior art.
- Figure 2 illustrates the invention where the rate of electricity is below a predetermined threshold level.
- Figure 2A illustrates the invention where the rate of electricity is above a predetermined threshold level.
- 25 - Figure 3 illustrates one embodiment of the invention and the equipment used in the liquefaction of air in the off-peak periods.
- Figure 4 illustrates another embodiment with an independent liquefier attached to the air separation unit used in the liquefaction of air in the off-peak periods.
- 30 - Figure 5 illustrates the equipment used to produce liquid air within the air separation unit.
- Figure 6 illustrates the liquid feed mode during peak periods.

- Figure 7 illustrates that the cold compression of the cold gas can be performed in a single step.
- Figure 8 illustrates an air separation unit based on that of Figure 2A in which cold low pressure nitrogen is compressed to between 10 and 20 bar abs.
- Figure 9 illustrates the pressurized cold gas after a cold compression in cold compressor can be heated and sent to a hot expander for power recovery or power production.
- Figure 10 illustrates an application of the invention where the compressed cold gas is sent to a gas turbine for power recovery.
- Figure 11 illustrates an IGCC application.
- Figure 12 illustrates a general method for extracting cold gas from the process when a liquid is fed to the system during peak periods.
- Figure 13 illustrates an operating mode of the air separation unit when the power peaks occur.

Description of Preferred Embodiments

According to the invention, there is provided a low temperature air separation process for producing pressurized gaseous product in an air separation unit using a system of distillation columns which comprises the following steps:

- i) cooling a compressed air stream in a heat exchange line to form a compressed cooled air stream;
- ii) sending at least part of the compressed, cooled air stream to a column of the system;
- iii) in a first period of time, liquefying a process stream to form a first liquid product and storing at least part of this first liquid product;
- iv) in a second period of time, sending the above stored first liquid product to the air separation unit as one of the feed;
- v) pressurizing at least one second liquid product stream;
- vi) vaporizing the above pressurized second liquid product stream in the heat exchange line to form pressurized gaseous product; and
- vii) during the above second period of time, extracting a cold gas from the air separation unit at a temperature between.

According to optional aspects of the invention:

- the pressurized gaseous product is oxygen product
- the pressurized gaseous product is nitrogen product
- 5 - the cold gas is extracted from the air separation unit cold box at a temperature between -195°C and -20°C , preferably between -180°C and -50°C
- the process stream of step c) contains any proportion of oxygen, nitrogen and argon
- 10 - the process stream of step c) is at least one of pure nitrogen, air, oxygen containing at least 37 mol. % oxygen, oxygen containing at least 65 mol. % oxygen, oxygen containing at least 85 mol.% oxygen and oxygen containing at least 99.5 mol.%
- the cold gas of step g) is chosen from the group comprising a nitrogen rich gas, pure nitrogen gas, air, a gas having a composition similar to
- 15 air, an oxygen rich gas and pure oxygen product
- the second liquid product of step e) is the same as the stored first liquid product of step c)
- step c) is performed if the electricity rate is below a predetermined
- 20 threshold
- step c) is performed only if the electricity rate is below a predetermined threshold
- step d) is performed if the electricity rate is above a predetermined threshold
- 25 - step d) is performed only if the electricity rate is above a predetermined threshold
- step g) is performed if the electricity rate is above a predetermined threshold
- step g) is performed only if the electricity rate is above a predetermined
- 30 threshold
- at least a portion of the cold gas of step g) is heated and expanded in a hot expander to recover energy

- at least a portion of the cold gas of step g) is injected into a gas turbine for energy recovery
- at least a portion of the cold gas of step g) is recycled back to the air separation unit
- 5 - the air separation unit supplies pressurized gaseous oxygen product to an IGCC facility
- the IGCC facility comprises a gas turbine further comprising the following steps:
 - 10 a) extracting air from the gas turbine if the rate of electricity is below a predetermined threshold; and
 - b) feeding above extracted air to the air separation unit
- injecting pressurized cold gas to the gas turbine if the rate of electricity is higher than a predetermined threshold
- the refrigeration of vaporizing LNG is recovered to reduce the liquefaction cost of the first liquid product
- 15 - reducing the flow of compressed air in the heat exchanger if the rate of electricity is above a predetermined threshold as compared to the amount of air cooled in the heat exchanger if the rate of electricity is below a predetermined threshold
- 20 - the cold gas is removed from the air separation unit without warming it in the heat exchange line
- the cold gas is removed from the air separation unit after being warmed partially in the heat exchange line
- the cold gas is removed from the air separation unit after being cooled
- 25 by traversing the warm end of the heat exchange line only

According to the invention, there is also provided a low temperature air separation process for producing pressurized gaseous product in an air separation unit using a system of distillation columns which comprises the following steps:

- 30 i) cooling a compressed air stream in a heat exchange line to form a compressed cooled air stream;
- ii) sending at least part of the compressed, cooled air stream to a column of the system;

- iii) in a first period of time, liquefying a process stream to form a first liquid product and storing at least part of the first liquid product;
- iv) in a second period of time, sending the above stored first liquid product to the air separation unit as one of the feeds;
- 5 v) pressurizing at least one second liquid product stream;
- vi) vaporizing the above pressurized second liquid product stream to form pressurized gaseous product in the heat exchange line; and
- vii) during the above second period of time, extracting a cold gas from the air separation unit and compressing the cold gas in a compressor
- 10 having an inlet temperature between -180°C and -50°C and an outlet temperature of at most -20°C to form a pressurized gas.

According to further optional aspects of the invention:

- the pressurized gaseous product is oxygen product
- 15 - the pressurized gaseous product is nitrogen product
- the process stream of step c) contains any proportion of oxygen, nitrogen and argon
- the process stream of step c) is at least one of pure nitrogen, air, oxygen containing at least 37 mol. % oxygen, oxygen containing at least 65 mol. % oxygen, oxygen containing at least 85 mol.% oxygen
- 20 and oxygen containing at least 99.5 mol.%
- the cold gas of step g) is chosen from the group comprising a nitrogen rich gas, pure nitrogen, air, a gas having a composition similar to air, an oxygen rich gas and pure oxygen product
- 25 - step c) is performed if the electricity rate is below a predetermined threshold
- step c) is performed only if the electricity rate is below a predetermined threshold
- step d) is performed if the electricity rate is above a predetermined
- 30 threshold
- step d) is performed only if the electricity rate is above a predetermined threshold

- step g) is performed if the electricity rate is above a predetermined threshold
- step g) is performed only if the of electricity rate is above a predetermined threshold
- 5 - the cold gas is compressed to a pressure between 35 and 80 bars abs in the compressor
- at least a portion of the pressurized gas is heated and expanded in a hot expander to recover energy
- 10 - at least a portion of the pressurized gas is injected into a gas turbine for energy recovery
- at least a portion of the pressurized gas is recycled back to the column system of the air separation unit
- the air separation unit supplies pressurized gaseous oxygen product to an IGCC facility
- 15 - the IGCC facility comprises a gas turbine further comprising the following steps:
 - a) extracting air from the gas turbine if the rate of electricity is below a predetermined threshold; and
 - b) feeding above extracted air to the air separation unit
- 20 - the process comprises the step of injecting the pressurized cold gas to the gas turbine if the rate of electricity is higher than a predetermined threshold
- the process comprises the steps of:
 - 25 a) warming the pressurized gas in the heat exchange line;
 - b) cooling additional gas in the heat exchange line to form cold additional gas; and
 - c) cryogenically compressing cold additional gas to higher pressure
- both gases are compressed to between 10 and 20 bars ab
- 30 - the refrigeration of vaporizing LNG is recovered to reduce the liquefaction cost of the first liquid product
- the process comprises reducing the flow of compressed air in the heat exchange line if the rate of electricity is above a predetermined

threshold as compared to the amount of air cooled in the heat exchange line if the rate of electricity is below a predetermined threshold

- 5
- the cold gas is removed from the air separation unit cold box without warming it in the heat exchange line
 - the cold gas is removed from the air separation unit cold box after being warmed partially in the heat exchange line
 - the cold gas is removed from the air separation unit cold box after being cooled by traversing the warm end of the heat exchange line
- 10
- the process includes the step of warming the pressurized gas in the heat exchange line
 - the air separation unit is contained within a cold box and the extracting a cold gas from the cold box at a temperature between -195°C and -20°C
- 15

According to a further aspect of the invention, there is provided an air separation apparatus comprising:

- 20
- a) a system of distillation columns;
 - b) a heat exchange line;
 - c) a cold box containing at least the system of distillation columns and the heat exchange line;
 - d) a conduit for sending feed air to the heat exchange line;
 - e) a conduit for sending cooled feed air from the heat exchange line to
- 25
- the column system;
 - f) means for sending a first liquid product to the column system;
 - g) a conduit for removing a liquid from a column of the column system;
 - h) a conduit for sending the liquid to the heat exchange line
 - i) a conduit for removing vaporized liquid from the heat exchange line;
- 30
- and
 - j) a conduit for extracting a gas from a column of the system and for removing the gas from the air separation apparatus without warming the gas by traversing the heat exchange line in its entirety.

Preferably, the conduit for extracting a gas is not connected to a reboiler-condenser of the apparatus.

According to further optional aspects, the apparatus comprises:

- 5 - means for storing the first liquid product outside any column of the column system
- a gas compressor connected to the conduit for extracting gas
- an air compressor having an inlet and an outlet, the inlet of the air compressor being connected to a compressed air conduit at an
10 intermediate point of the heat exchanger
- a gas turbine having an expander and a conduit for sending gas compressed in the cold gas compressor to a point upstream the expander
- a conduit for removing the gas from the air separation apparatus
15 without warming the gas in the heat exchange line
- means for liquefying a gas to form the first liquid product

The invention will now be described in greater detail with reference to the figures. Figures 2 to 13 show air separation processes according to the invention.

20

The invention is in particular suitable for the liquid pumped air separation process.

The process has at least two modes of operation, one corresponding to the periods when the rate of electricity is below a predetermined threshold (Figure 2) and one
25 corresponding to periods when the rate of electricity is above a predetermined threshold (Figure 2A).

When the rate of electricity is below a predetermined threshold, the apparatus operates according to Figure 2 as follows. Atmospheric air is compressed by a Main
30 Air Compressor (MAC) 1 to a pressure of about 6 bar absolute, it is then purified in an adsorber system 2 to remove impurities such as moisture and carbon dioxide that can freeze at cryogenic temperature to yield a purified feed air. A portion 3 of this purified feed air is then cooled to near its dew point in heat exchanger 30 and is

introduced into a high pressure column **10** of a double column system in gaseous form for distillation. Nitrogen rich liquid **4** is extracted at the top of this high pressure column and a portion is sent to the top of the low pressure column **11** as a reflux stream. The oxygen-enriched liquid stream **5** at the bottom of the high pressure column is also sent to the low pressure column as feed. The two liquids **4** and **5** are subcooled before being expanded. An oxygen liquid **6** is extracted from the bottom of the low pressure column **11**, pressurized by pump to a required pressure then vaporized in the exchanger **30** to form the gaseous oxygen product **7**. Another portion **8** of the purified feed air is further compressed in a Booster Air Compressor (BAC) **20** to high pressure for condensation in the exchanger **30** against the vaporizing oxygen enriched stream. Depending upon the pressure of the oxygen rich product, the boosted air pressure is typically about 65 to 80 bar for oxygen pressures of about 40-50 bar or sometimes over 80 bar. As an indication, the flow of stream **8** represents about 30-45% of the total flow of compressor **1**. The condensed boosted air **9** is also sent to the column system as feed for the distillation, for example to the high pressure column. Part of the liquid air (stream **62**) may be removed from the high pressure column and sent to the low pressure column. It is also possible to extract nitrogen rich liquid from the top of the high pressure column then pump it to high pressure (stream **13**) and vaporize it in the exchanger in the same way as with oxygen liquid. A small portion of the feed air (stream **14**) is further compressed and expanded into the column **11** to provide the refrigeration of the unit. Optionally alternative or additional means of providing refrigeration may be used, such as Claude expanders or nitrogen expanders.

Waste nitrogen or low pressure nitrogen is removed from the top of the low pressure column and all of the stream warms in exchanger **30**.

Argon is optionally produced using a standard argon column whose top condenser is cooled with oxygen enriched liquid **5**.

Nitrogen gas can be compressed to high pressure as needed by compressors **45**, **46** to yield a nitrogen product stream **48**.

During this period when the rate of electricity is below a predetermined threshold, air is liquefied by any means described in Figures 3 to 5. For example, in Figure 2, gaseous compressed air free of moisture and CO₂ (stream **47**) is taken after the adsorber **2** and sent to an external liquefier **60** to produce a liquid air stream **49**.

5 This liquid air is stored in tank **50**. Preferably no liquid air is sent from the storage tank **50** to the column during this period.

When the rate of electricity is above the predetermined threshold, the apparatus operates according to Figure 2A as follows:

10

Liquid air flows from the storage tank **50** to the high pressure column **10** via conduit **60** connected to conduit **9** and to the low pressure column **11** via conduit **61**. Preferably liquefaction of air in the liquefier does not take place during these periods.

15

When sending liquid air from the tank **50** to the column system, the flow of the Main Air compressor **1** can be reduced by an amount essentially equal to the amount of liquid air so that the overall balance in oxygen of the feeds of the unit can be preserved. As indicated above, the flow **14** of the expander **44** is rather small and

20

can be optionally eliminated and flow of compressor **1** will be adjusted accordingly. The lost refrigeration work resulted from the omission of the expander can be easily compensated by the amount of the above liquid air. Therefore by replacing the flow of stream **8** with a liquid air flow via **60**, the compressor **20** can be stopped and the flow of compressor **1** can be reduced by 20-55%. These reductions result in a sharp

25

drop in the power consumption of the unit. Since the flow of various streams feeding the column system remains similar, the distillation operation will be undisturbed by those changes and the product purities will not suffer. However, by feeding an important amount of liquid air and by eliminating the boosted air portion **9** and

30

reducing the flow of compressor **1**, the main exchanger **30** becomes unbalanced in terms of ingoing and outgoing flows and refrigeration. In order to restore the flow and refrigeration balances, an outgoing cold gas flow at cryogenic temperature must be extracted from the system. Figure 2A illustrates a possible arrangement of such operation in which part **40** of the waste nitrogen from the low pressure column is

removed from the system without being warmed in the exchanger **30** or any other exchanger. The stream **40** is optionally compressed in a compressor **70** whose inlet is at a cryogenic temperature. The cold gas stream can be any cold gas with suitable flow and temperature including gaseous oxygen product at the bottom of the
5 low pressure column **11**. The cold gas temperature leaving the cold box is from about -195°C to about -20°C , preferably between -180°C and -50°C . The main exchanger **30**, and other cryogenic heat exchangers such as subcoolers, constitute a heat exchange system or sometimes called heat exchange line of an air
10 separation unit. This heat exchange line promotes heat transfer between the incoming feed gases and the outgoing gaseous products to cool the feed gases to near their dew points before feeding the columns, and to warm the gaseous products to ambient temperature.

The power needed to liquefy air is generally very high and normally one cannot
15 justify economically the use of liquid air to replace the boosted air stream as described above. However, since there exists a large difference in power rate between peak and off-peak periods as explained earlier, it is conceivable to perform the energy-intensive step of air liquefaction during the periods when power rate is low, for example at night, such that the cost incurred by this liquefaction step is not
20 excessive. Therefore it becomes clear that, during the peak periods, one can use this liquid produced earlier inexpensively to feed the system and reduce the flows or power consumed by the unit. Such maneuver sharply reduces the power consumption of the unit. Consequently, the expense of paying the high price of power during peak periods can be minimized. In essence, this new invention allows
25 producing the molecules of gases needed for the distillation during low power rate periods and then efficiently use those molecules during the high power rate periods to achieve the overall cost savings.

The cold gas extracted from the system during peak time can be compressed
30 economically at low temperature to higher pressure. The power consumed by this cold compression is low compared to a warm compression performed at ambient temperature. Indeed, the power consumed by a compressor wheel is directly proportional to its inlet absolute temperature. A compressor wheel admitting at 100K

would consume about 1/3 the power of a compressor wheel admitting at ambient temperature of 300K. Therefore, by utilizing cold compression, one can further improve the energy value of a gas by raising its pressure at the expense of relatively low power requirement. It is clear that the cold gas extracted from the process, instead of subjecting it to a cold compression process, can be used for other purposes, for example to chill another process, to chill another gas, etc. Depending upon the applications, instead of cold compressing the cold gas directly, it is possible to warm the cold gas slightly by some other external recovery heat exchangers to another temperature, still cryogenic (less than -50°C) then compress it by cold compressor.

It is useful to note that traditional air separation units also constantly discharge into the atmosphere small cold streams such as non-condensable purge of condensers or liquid purge of vessels or columns. These purge streams are usually very small in flow, usually less than 0.2% of the total air feed. Unless there is a rare gas recovery unit (Neon, Krypton, Xenon, etc.) that can utilize those purge streams as feeds, they are rejected without any cold recovery since their flow range is too small. Meanwhile, the recovered cold gas of this invention is much larger in flow: its minimum flow rate is at about 4% of the minimum gaseous air feed to the system and can be as much as 70% of total air feed rate.

The liquefaction of air in the off-peak periods can be conducted in another cryogenic plant, using different equipment as illustrated in Figure 3. Here air is compressed in compressor **100** sent to a liquefier **200** and then to storage tank **50**. The liquid air is sent from the storage tank **50** to an ASU as described in Figure 2A during peak periods, the storage tank being in this case outside the cold box.

The liquefaction can also be performed by using an independent liquefier attached to the air separation unit as illustrated in Figure 4 where air from main air compressor **1** is divided, one part being sent to the liquefier **200** and the rest to the ASU. Air from the liquefier is then sent to the storage tank **50** and thence back to the ASU during peak periods.

Alternatively the liquid air can be produced within the ASU, using the same equipment as in the cases of integrated liquefier as described in Figure 5. Figure 6 illustrates the liquid feed mode during peak periods.

- 5 The liquid storage tank can be a vessel located externally to the cold box or a vessel located inside the cold box. It is also possible to use an oversized bottom of a distillation column as liquid storage tank, in this case, the stored liquid has similar composition as the liquid being produced at the bottom of the vessel. The liquid level is allowed to rise at the bottom of the column or vessel during the filling.

10

Some additional operating conditions of various process parameters related to the invention will now be described:

15

- The quantity of liquid air to be produced in off-peak time depends upon the relative length of the off-peak duration over the length of the peak duration. The shorter the off-peak time, the higher is the required liquefaction rate and vice-versa. In the peak mode, the liquid air feed rate can be about 20-30% of the total air feed under normal conditions.

20

- Figure 12 can be used to provide a general guideline for extracting cold gas from the process when a liquid **30** is fed to the system during peak periods: as shown, the column system **71** is connected to the exchanger line **65**, liquid products **15**, **16** are delivered by pumps **20**, **21** to exchanger **65** for vaporization. The total of all pressurized liquid product vaporizing in the exchanger **65** is called the Total Vaporized Liquid. Pressurized gases **31**, **32** are cooled and condensed in exchanger **65** against vaporizing products **15**, **16** to yield liquid feeds **25**, **26** which are then expanded into the column system **71**. The total flow of all condensed pressurized streams is called the Total Incoming Liquid. Cold gas **11** can be extracted from the system according to the following guideline: its flow is about 1.6 to 2.6 times the Total Vaporized Liquid minus the Total Incoming Liquid:

25

30

$$\text{Flow of cold gas} = k [\text{Total Vaporized Liquid} - \text{Total Incoming liquid}], \text{ with } k = 1.6 \text{ to } 2.6$$

- 5 - It is also possible to extract liquid product (oxygen, nitrogen or combination of those liquid products along with the cold gas described above by increasing the amount of liquid air feed, therefore supplying the needed refrigeration for the production of liquid product or products.

Additional Embodiments

- 10 1. The cold compression of the cold gas can be performed in a single step as illustrated above in Figure 2A. When the final pressure of the compressed cold gas is relatively low, i.e. the compressed gas temperature remains at a low level then it is possible to increase the compressed gas flow, as illustrated in Figure 7, by cooling additional air **85** from the Main air compressor **1** (or nitrogen gas) with the compressed cold gas from the cold compressor **70** in exchange line **30** and then
- 15 compressing the additional gas to higher pressure in cold compressor **75**. The two cold compressed streams are then mixed upstream of the heat exchange line **30** to form stream **95**. This exchanger can be combined with the main exchanger **30** of Figure 2A. Figure 8 also describes this embodiment.

20

Figure 8 shows an ASU based on that of Figure 2A in which cold low pressure nitrogen **40** is compressed to between 10 and 20 bar abs., preferably 15 bar abs. The gas compressed in cold compressor **70** is warmed at the warm end only of the heat exchanger **30**. Part of the feed air compressed in main air compressor **1** is purified, cooled in the

25 exchanger **30** to an intermediate temperature and then compressed in cold compressor **75** to the same pressure as that at the outlet of cold compressor **70**. The two streams compressed in the cold compressors **70, 75** are then mixed and sent for example to the combustion chamber of

30 a gas turbine where the mixed stream is heated then expanded in a turbine for power recovery.

2. Another embodiment is described in Figure 9, the pressurized cold gas after a cold compression in cold compressor **70** can be heated and sent to a hot expander **110** for power recovery or power production. This power being produced during peak time can be very valuable and can be export to generate additional revenue. The nitrogen from cold compressor **70** is warmed in exchanger **80** and further warmed by heater **90** before being expanded in expander **110**. The exhaust gas from expander **110** is sent to exchanger **80** and used to warm the cold compressed nitrogen.
3. Figure 10 illustrates the application where the compressed cold gas is sent to a gas turbine for power recovery. Here the nitrogen from cold compressor **70** is sent to the combustion chamber **150** of the gas turbine, after being mixed with air from gas turbine compressor **120**. Fuel **140** is also sent to the combustion chamber and the exhaust gas is expanded by expander **130** to form gas **160**. A compression arrangement similar to the one illustrated in Figure 8 or 9 using two compressors and mixing cold compressed air with cold compressed nitrogen could also be used in this application.
4. This invention may be used to improve the economics of IGCC application. Indeed, the IGCC (integrated gasification combined cycle) process is based upon the concept of gasifying coal, petroleum coke, etc., using oxygen gas to produce synthetic gas (syngas) which is then burned in a gas turbine to generate power. A steam generation sub-system is added to form a combined cycle for additional power generation. Since the power demand from the IGCC usually fluctuates widely between day and night, and the gasifier is not very flexible in terms of throughput variations so that it is problematic to have a stable operating mode. Furthermore the equipment is poorly utilized during off-peak time. The problem is further compounded by the fact that at night, with lower ambient temperature, the compressor of the gas turbine can generate more flow to the turbine system. However, the latter because of lower demand cannot utilize this additional capacity. In a similar fashion, in the

daytime, when the ambient temperature is higher, the compressor of the gas turbine sees its flow reduced and this, during the time where additional power generation is desirable. By incorporating the features of this new invention to an IGCC plant we can improve significantly the performance of the unit thanks to the synergy of the air separation plant and the IGCC:

- At night, as shown in Figure 11, when the power demand is low and higher compressor flow is available, air from the compressor **120** of the gas turbine can be diverted to the air separation plant to provide at least part of the flow and power for the liquefaction of air. An elevated pressure ASU could also be used advantageously since it can use the elevated pressure air from the gas turbine directly. By taking more flow and consuming more power, hence more syngas for the gas turbine, to liquefy the air during off-peak time, the IGCC portion can be kept relatively constant during the night time. In Figure 11, block **170** represents the gasifier and block **180** represents the synthetic gas/fuel treatment, filtration, compression, etc.
- In the daytime, the capacity of the air compressor **120** of the gas turbine is reduced due to warmer ambient temperature. The air extraction of the night mode can be stopped. The liquid air produced at night and sent to storage **50** can then be used in the Air separation plant and its power consumption is reduced, so that more power can therefore be diverted to supply the high demand of the daytime. Furthermore, the cold gas extracted from the ASU can be compressed economically in cold compressor **70** to higher pressure for injection into the gas turbine and to balance out the flow deficiency, thereby generating even more power.

For applications involving injecting compressed gas into combustion turbine or gas turbine, the cold compression arrangements of Figures 7 and 8 are well adapted: the pressure requirement for the injected gas is about 15-20 bar which is exactly the range of pressure called for by the process of those figures, and by mixing the cold compressed air stream with the cold compressed nitrogen rich gas as shown, one can assure a good supply of oxygen required for the combustion process.

5. This invention may be used advantageously as a distillation and efficiency enhancement of an air separation unit. An embodiment of this feature is illustrated in Figure 13, which describes an operating mode of the air separation unit when the power peaks occur. Liquid air 30 produced during off-peak periods is fed to the column system. Cold gas extracted from the top of the distillation column is cold compressed to higher pressure as stream 13. A portion of this higher pressure gas (stream 14) is recycled back to the main exchanger 65 wherein it is liquefied to form a liquid stream 15 and fed to the column system. This recycle and liquefaction improves the vaporization of compressed liquid stream 23 in the main exchanger 65 and some flow reduction of liquid feed 30 can be achieved. Also, the presence of this liquid stream 15 at the cold end of exchanger 65 would balance the cold end portion of the plant, and prevent the liquefaction of stream 2 which could be detrimental to the heat transfer in exchanger 65 and could cause distillation problems in the column 30. If needed, a portion of the compressed gas (stream 12) can also be cooled and recycled to the top of the high pressure column to enhance the distillation of the column system following cooling in heat exchange line 30 to form stream 16. During off-peak periods, the air separation plant operates according to the process described in Figure 2 (for the clarity of the drawing, the expanders and compressors of the off-peak mode are not shown). The process of Figure 2 is a typical one for pumped liquid air separation plants, it is obvious to a person skilled in the art that other liquid pumped processes such as cold booster process or single Claude expander liquid pumped process, etc., can also be utilized for the off-peak mode as well. The liquid air needed for the peak periods could be produced by an external liquefier as shown in Figure 2. Of course, as mentioned previously, an integrated liquefier can be implemented as well.
6. An additional embodiment may be used in cold recovery from LNG vaporization. Cryogenic plants have been used to recover the cold released from the vaporization of LNG in peak-shaving or vaporization

terminal LNG plants. This refrigeration is used to lower the cost of producing liquid products in Air Separation plants. With this invention, the refrigeration of vaporized LNG can be used to lower the liquefaction cost of liquid air in off-peak periods; which therefore, results in more cost savings when the liquid is fed back to the ASU in peak periods as described in this concept.

The above embodiments describe the use of liquid air as the intermediate liquid to transfer the refrigeration and gas molecules between the peak and off-peak periods. It is obvious to someone skilled in the art that any liquid with various compositions of air components can be used to apply this technique. For example, the liquid can be an oxygen rich liquid extracted at the bottom of the high pressure column containing about 35 to 42 mol. % oxygen or a liquid extracted near the bottom of the low pressure column with 70-97 mol. % oxygen content, or even pure oxygen product. The liquid can also be a nitrogen rich stream with little oxygen content. It is useful to note when this nitrogen rich liquid stream containing almost no oxygen is fed back to the air separation unit during peak periods, the air feed flow will not be reduced but must be maintained constant to satisfy the supply of oxygen molecules. In this situation the power saving can be achieved for example by shutting down the nitrogen product compressors (compressors 45, 46 of Figure 2) and supplying the nitrogen product by cold compressors that consume significantly less power. In another word, the concept is applicable to an intermediate liquid of any composition of air components.

The invention is developed for constant product demand under variable power rate structure. It is clear that the invention can be extended to a system with variable product demand as well. For example, during periods with low demand in oxygen, one can apply the concept by feeding liquid air to the system and reducing the feed air flow. The unused oxygen can be stored as a liquid oxygen product such that the distillation columns can be kept unchanged. This liquid oxygen can be fed back to the system when the demand of oxygen is high. By adjusting the flow of liquid air feed, oxygen liquid, cold gas extraction and gaseous air feed, or another liquid like

liquid nitrogen, one can provide an optimum process satisfying both variable product demand and variable power rate constraints.

5 Although the invention has been described with reference to certain preferred embodiments, those skilled in the art will recognize that there are other embodiments of the invention within the spirit and scope of the claims. Thus, the present invention is not intended to be limited to the specific embodiments in the examples given above.

CLAIMS

1. A low temperature air separation process for producing pressurized gaseous product in an air separation unit contained within a cold box using a system of distillation columns which comprises the following steps:
- 5
- a. Cooling a compressed air stream in a heat exchange line to form a compressed cooled air stream
 - b. Sending at least part of the compressed, cooled air stream to a column of the system
 - c. In a first period of time, only if the electricity rate is below a predetermined threshold, liquefying a process stream to form a first liquid product and storing at least part of this first liquid product
 - d. In a second period of time, only if the electricity rate is above a predetermined threshold sending the above stored first liquid product to the air separation unit as one of the feeds
 - e. Pressurizing at least one second liquid product stream
 - f. Vaporizing the above pressurized second liquid product stream in the heat exchange line to form pressurized gaseous product
 - g. During the above second period of time, only if the electricity rate is above a predetermined threshold extracting a cold gas from the air separation unit cold box at a temperature between -195°C and -20°C .
- 10
- 15
- 20
- 25
2. The process of claim 1 wherein the pressurized gaseous product is oxygen product.
3. The process of claim 1 wherein the pressurized gaseous product is nitrogen product.

4. The process of claim 1 wherein the process stream of step c) contains any proportion of oxygen, nitrogen and argon.

5. The process of claim 1 wherein the process stream of step c) is at least one of pure nitrogen, air, oxygen containing at least 37 mol. % oxygen, oxygen containing at least 65 mol. % oxygen, oxygen containing at least 85 mol.% oxygen and oxygen containing at least 99.5 mol.%.

6. The process of claim 1 wherein the cold gas of step g) is chosen from the group comprising a nitrogen rich gas, pure nitrogen gas, air, a gas having a composition similar to air, an oxygen rich gas and pure oxygen product.

7. The process of claim 1 wherein the second liquid product of step e) is the same as the stored first liquid product of step c).

8. The process of claim 1 wherein at least a portion of the cold gas of step g) is heated and expanded in a hot expander to recover energy.

9. The process of claim 1 wherein at least a portion of the cold gas of step g) is injected into a gas turbine for energy recovery

10. The process of claim 1 wherein at least a portion of the cold gas of step g) is recycled back to the air separation unit.

11. The process of claim 1 wherein the air separation unit supplies pressurized gaseous oxygen product to an IGCC facility

12. The process of claim 11 wherein the IGCC facility comprises a gas turbine further comprising the following steps:

- a. Extracting air from the gas turbine if the rate of electricity is below a predetermined threshold
- b. Feeding above extracted air to the air separation unit

5 13. The process of claim 11 comprising the step of injecting pressurized cold gas to the gas turbine if the rate of electricity is higher than a predetermined threshold.

10 14. The process of claim 1 wherein the refrigeration of vaporizing LNG is recovered to reduce the liquefaction cost of the first liquid product.

15 15. The process of claim 1 comprising reducing the flow of compressed air in the heat exchanger if the rate of electricity is above a predetermined threshold as compared to the amount of air cooled in the heat exchanger if the rate of electricity is below a predetermined threshold.

16. The process of claim 1 wherein the cold gas is removed from the air separation unit without warming it in the heat exchange line.

20 17. The process of claim 1 wherein the cold gas is removed from the air separation unit after being warmed partially in the heat exchange line.

25 18. The process of claim 17 wherein the cold gas is removed from the air separation unit after being warmed by traversing the warm end of the heat exchange line only.

19. A low temperature air separation process for producing pressurized gaseous product in an air separation unit using a system of distillation columns which comprises the following steps:

- a) Cooling a compressed air stream in a heat exchange line to form a compressed cooled air stream
- b) Sending at least part of the compressed, cooled air stream to a column of the system
- 5 c) In a first period of time, only if the electricity rate is below a predetermined threshold, liquefying a process stream to form a first liquid product and storing at least part of the first liquid product
- d) In a second period of time, only if the electricity rate is above a predetermined threshold sending the above stored first liquid product to the air
- 10 separation unit as one of the feeds
- e) Pressurizing at least one second liquid product stream
- f) Vaporizing the above pressurized second liquid product stream to form pressurized gaseous product in the heat exchange line
- g) During the above second period of time, only if the electricity rate is above
- 15 a predetermined threshold extracting a cold gas from the air separation unit and compressing the cold gas in a compressor having an inlet temperature between -180°C and -50°C and an outlet temperature of at most -20°C to form a pressurized gas.
- 20 20. The process of claim 19 wherein the pressurized gaseous product is oxygen product.
21. The process of claim 19 wherein pressurized gaseous product is nitrogen product.
- 25 22. The process of claim 19 wherein the process stream of step c) contains any proportion of oxygen, nitrogen and argon.
23. The process of claim 19 wherein the process stream of step c) is at least
- 30 one of pure nitrogen, air, oxygen containing at least 37 mol. % oxygen, oxygen

containing at least 65 mol. % oxygen, oxygen containing at least 85 mol.% oxygen and oxygen containing at least 99.5 mol.%.

5 24. The process of claim 19 wherein the cold gas of step g) is chosen from the group comprising a nitrogen rich gas, pure nitrogen, air, a gas having a composition similar to air, an oxygen rich gas and pure oxygen product.

10 25. The process of claim 19 wherein the cold gas is compressed to a pressure between 35 and 80 bars abs in the compressor.

26. The process of claim 19 wherein at least a portion of the pressurized gas is heated and expanded in a hot expander to recover energy.

15 27. The process of claim 19 wherein at least a portion of the pressurized gas is injected into a gas turbine for energy recovery

28. The process of claim 19 wherein at least a portion of the pressurized gas is recycled back to the column system of the air separation unit

20 29. The process of claim 19 wherein the air separation unit supplies pressurized gaseous oxygen product to an IGCC facility

25 30. The process of claim 29 wherein the IGCC facility comprises a gas turbine further comprising the following steps:

a. Extracting air from the gas turbine if the rate of electricity is below a predetermined threshold

b. Feeding above extracted air to the air separation unit.

31. The process of claim 19 comprising the step of injecting the pressurized cold gas to the gas turbine if the rate of electricity is higher than a predetermined threshold.

5 32. The process of claim 19 further comprising the following steps:

a) Warming the pressurized gas in the heat exchange line

b) Cooling additional gas in the heat exchange line to form cold additional gas

10 c) Cryogenically compressing cold additional gas to higher pressure

33. The process of claim 32 wherein both gases are compressed to between 10 and 20 bars abs.

15 34. The process of claim 19 wherein the refrigeration of vaporizing LNG is recovered to reduce the liquefaction cost of the first liquid product.

20 35. The process of claim 19 comprising reducing the flow of compressed air in the heat exchange line if the rate of electricity is above a predetermined threshold as compared to the amount of air cooled in the heat exchange line if the rate of electricity is below a predetermined threshold.

36. The process of claim 19 wherein the cold gas is removed from the air separation unit cold box without warming it in the heat exchange line.

25 37. The process of claim 19 wherein the cold gas is removed from the air separation unit cold box after being warmed partially in the heat exchange line.

38. The process of claim 37 wherein the cold gas is removed from the air separation unit cold box after being warmed by traversing the warm end of the heat exchange line only.

5 39. The process of claim 19 comprising the step of warming the pressurized gas in the heat exchange line.

40. An air separation apparatus comprising

- 10 a) a system of distillation columns
b) a heat exchange line
c) a cold box containing at least the system of distillation columns and the heat exchange line
d) a conduit for sending feed air to the heat exchange line
15 e) a conduit for sending cooled feed air from the heat exchange line to the column system
f) means for sending a first liquid product to the column system
g) a conduit for removing a liquid from a column of the column system
h) a conduit for sending the liquid to the heat exchange line
20 i) a conduit for removing vaporized liquid from the heat exchange line and
j) a conduit for extracting a gas from a column of the system and for removing the gas from the air separation apparatus without warming the gas by traversing the heat exchange line in its entirety.

25 41. The apparatus of Claim 40 comprising means for storing the first liquid product outside any column of the column system.

42. The apparatus of Claim 40 comprising a gas compressor connected to the conduit for extracting gas.

43. The apparatus of Claim 40 comprising an air compressor having an inlet and an outlet, the inlet of the air compressor being connected to a compressed air conduit at an intermediate point of the heat exchanger.

5 44. The apparatus of Claim 40 comprising a gas turbine having an expander and a conduit for sending gas compressed in the cold gas compressor to a point upstream the expander.

10 45. The apparatus of Claim 40 comprising a conduit for removing the gas from the air separation apparatus without warming the gas in the heat exchange line.

46. The apparatus of Claim 40 comprising means for liquefying a gas to form the first liquid product.

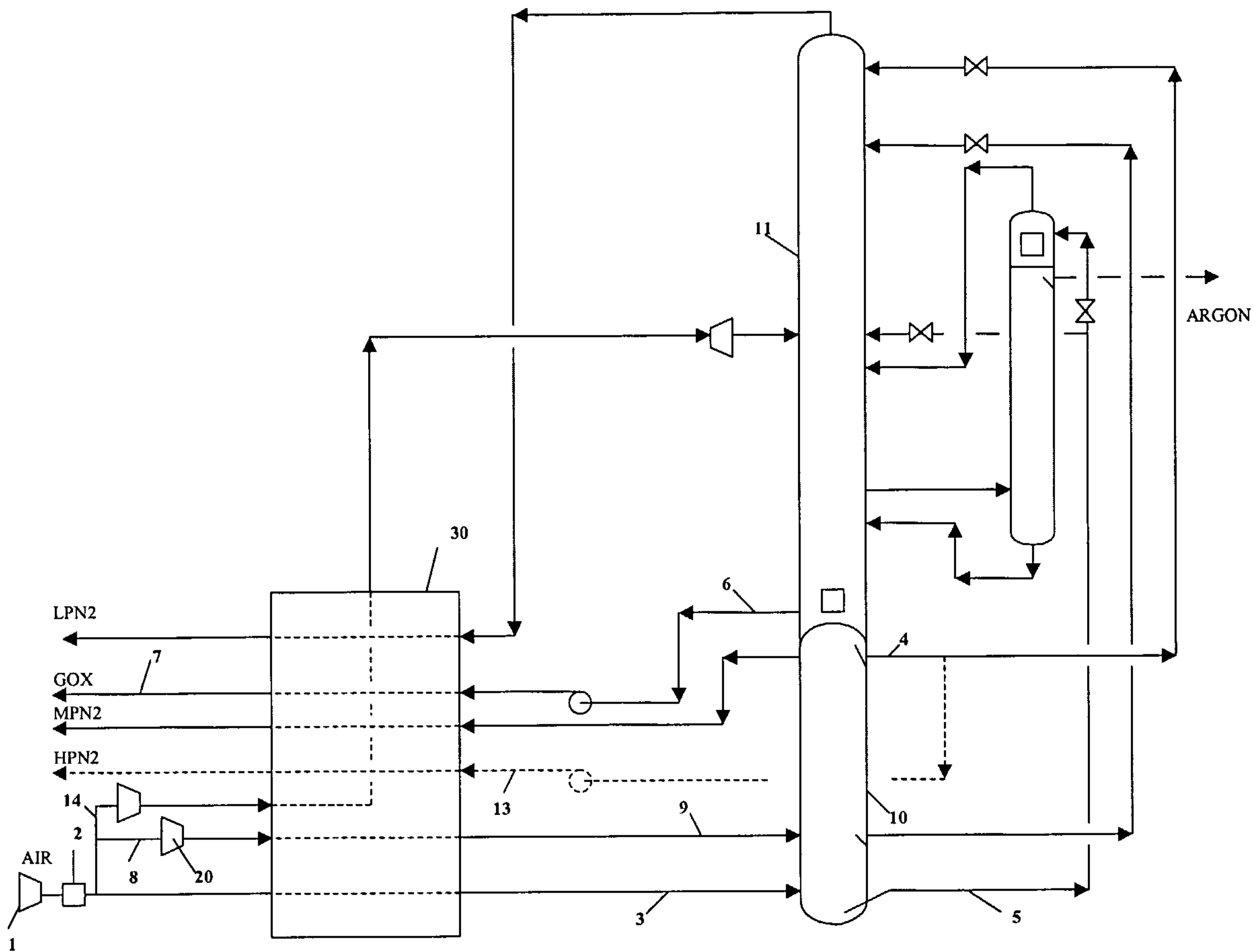

Figure 1 – PRIOR ART

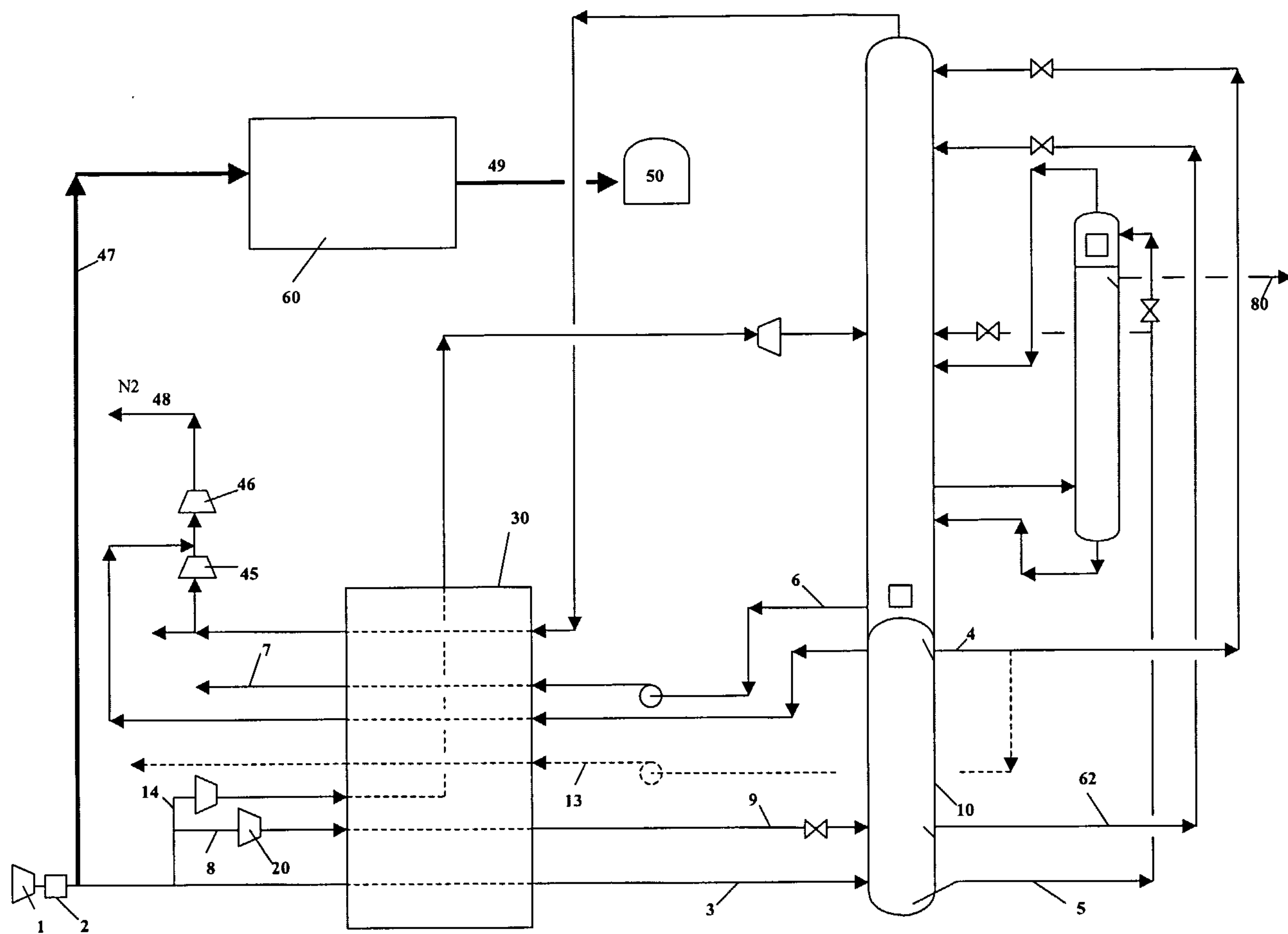

Figure 2

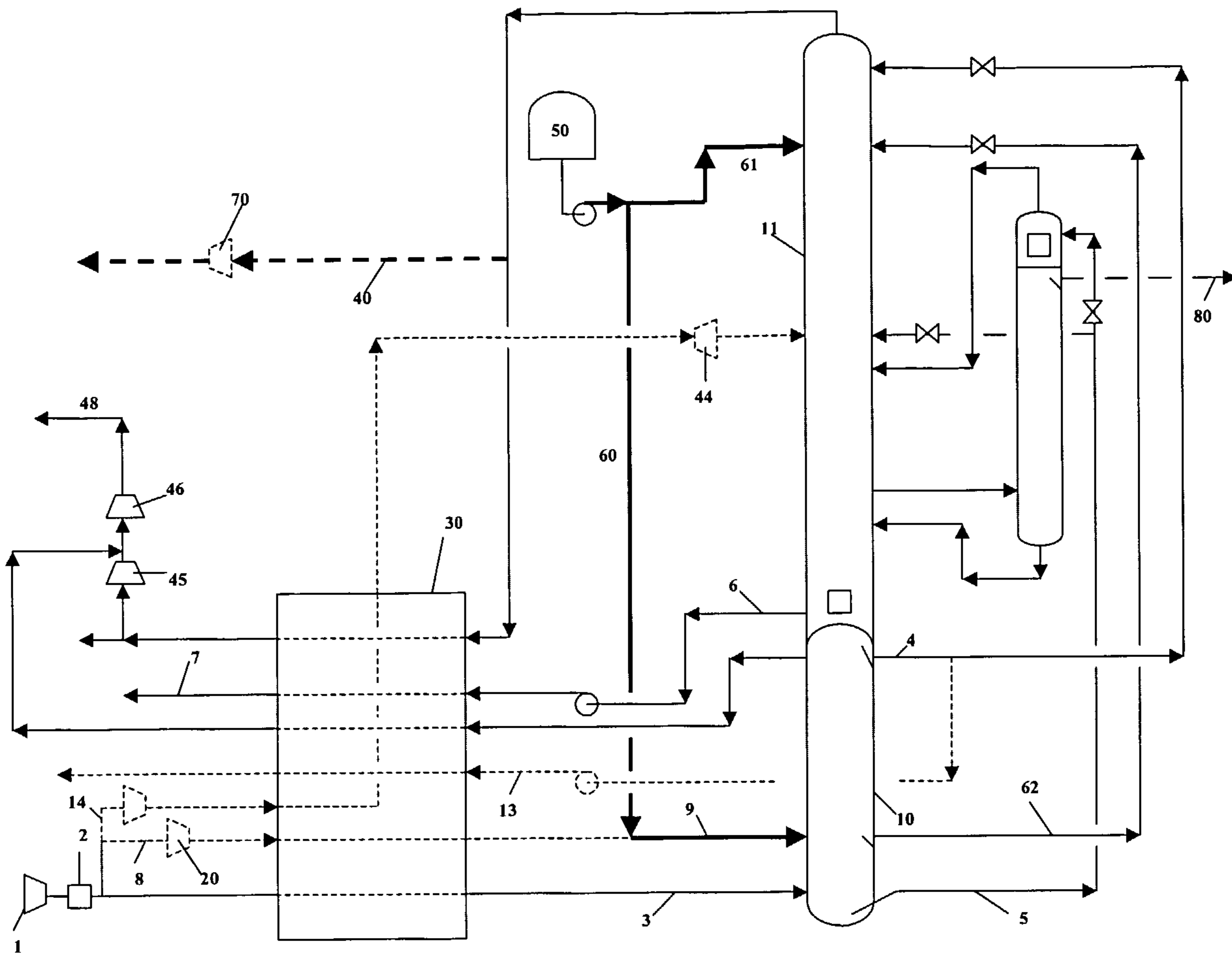

Figure 2A

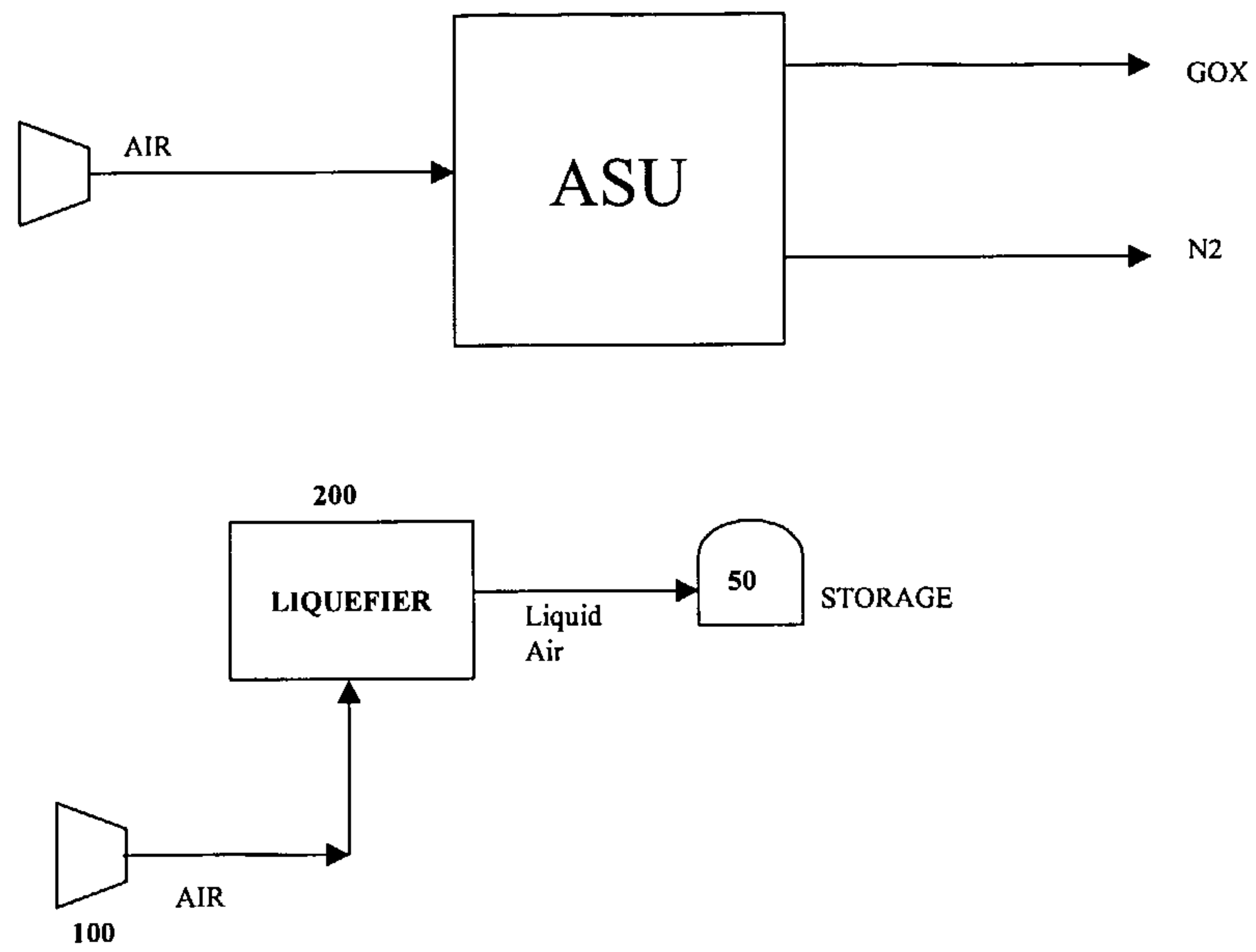

Figure 3

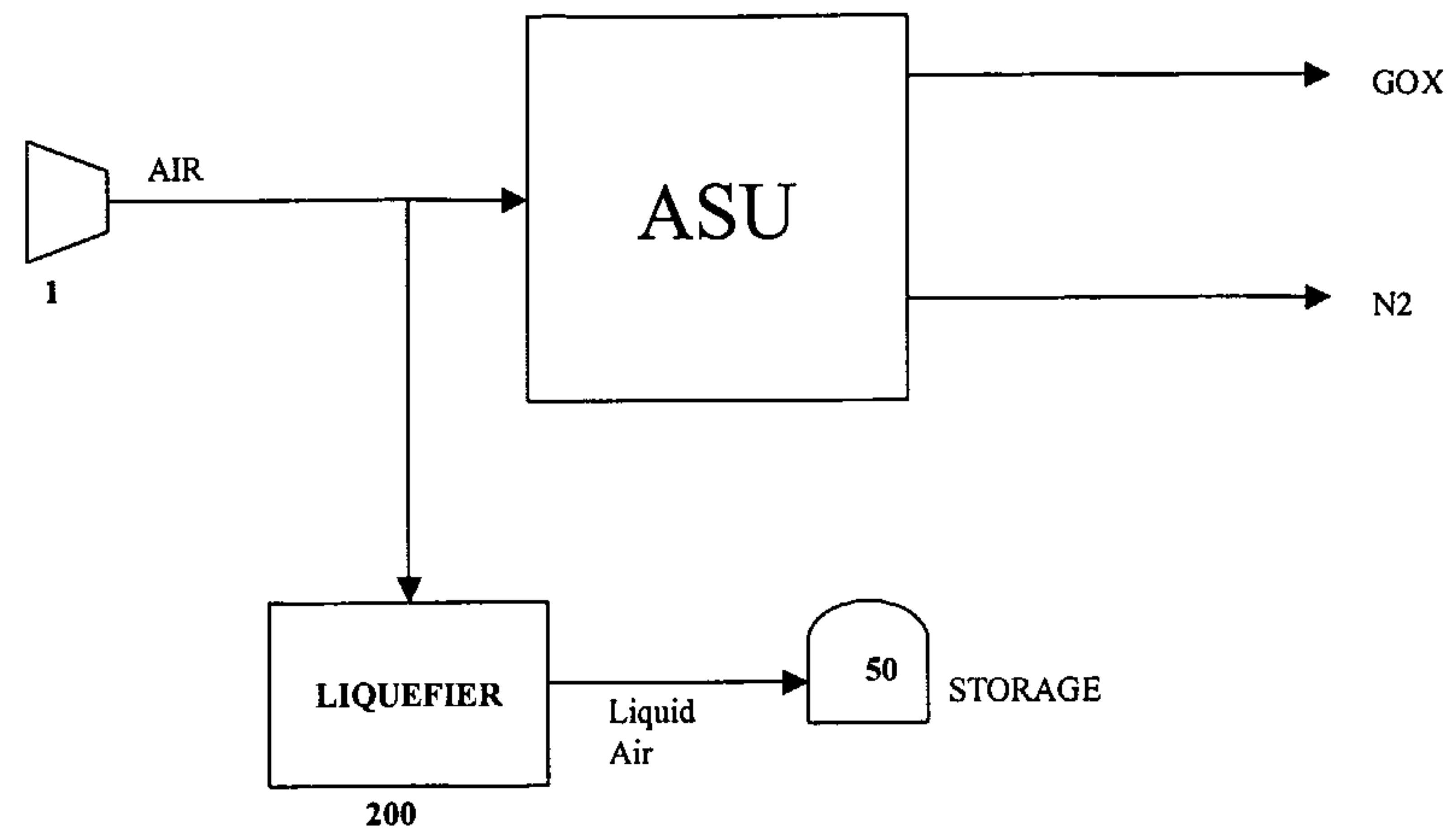

Figure 4

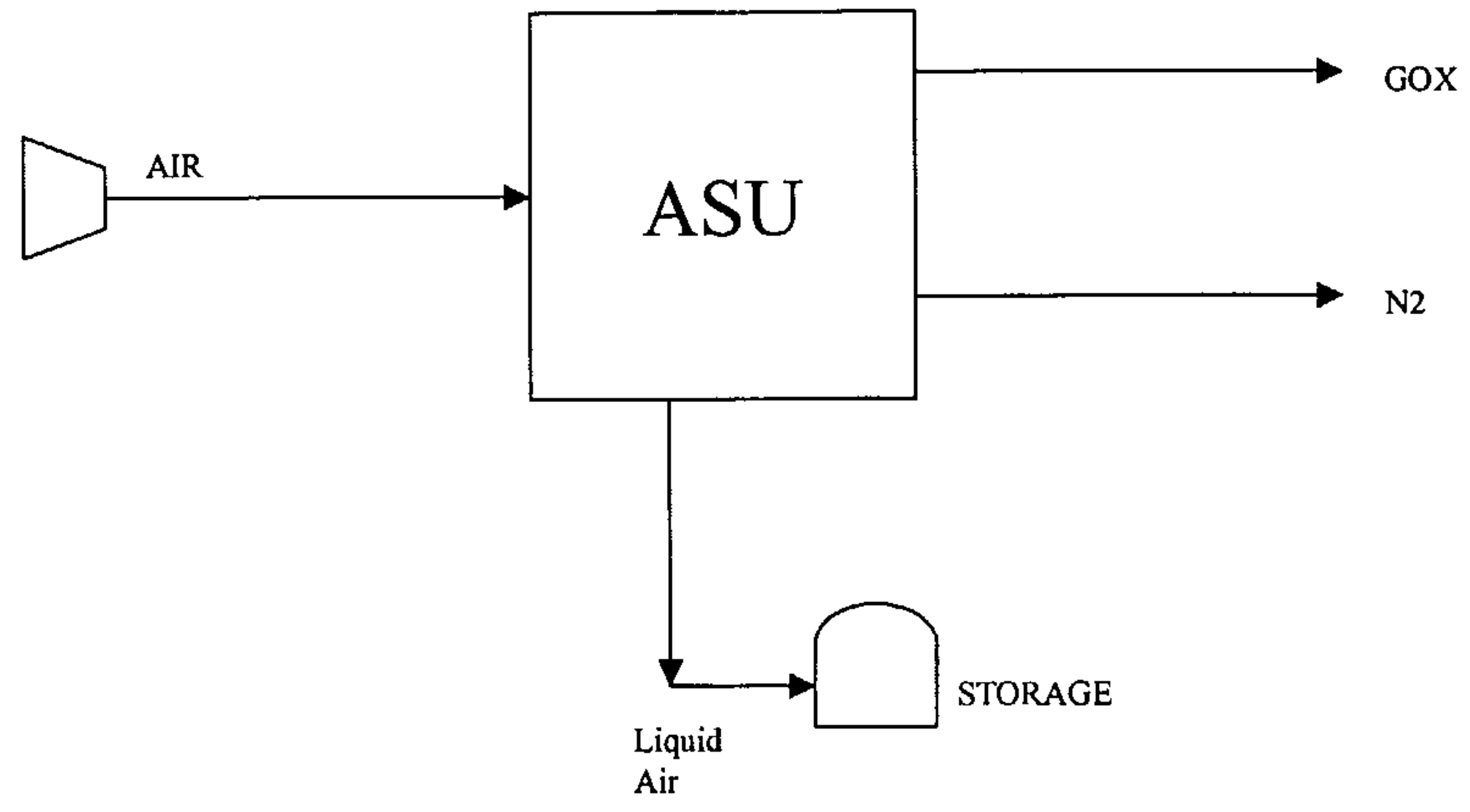

Figure 5

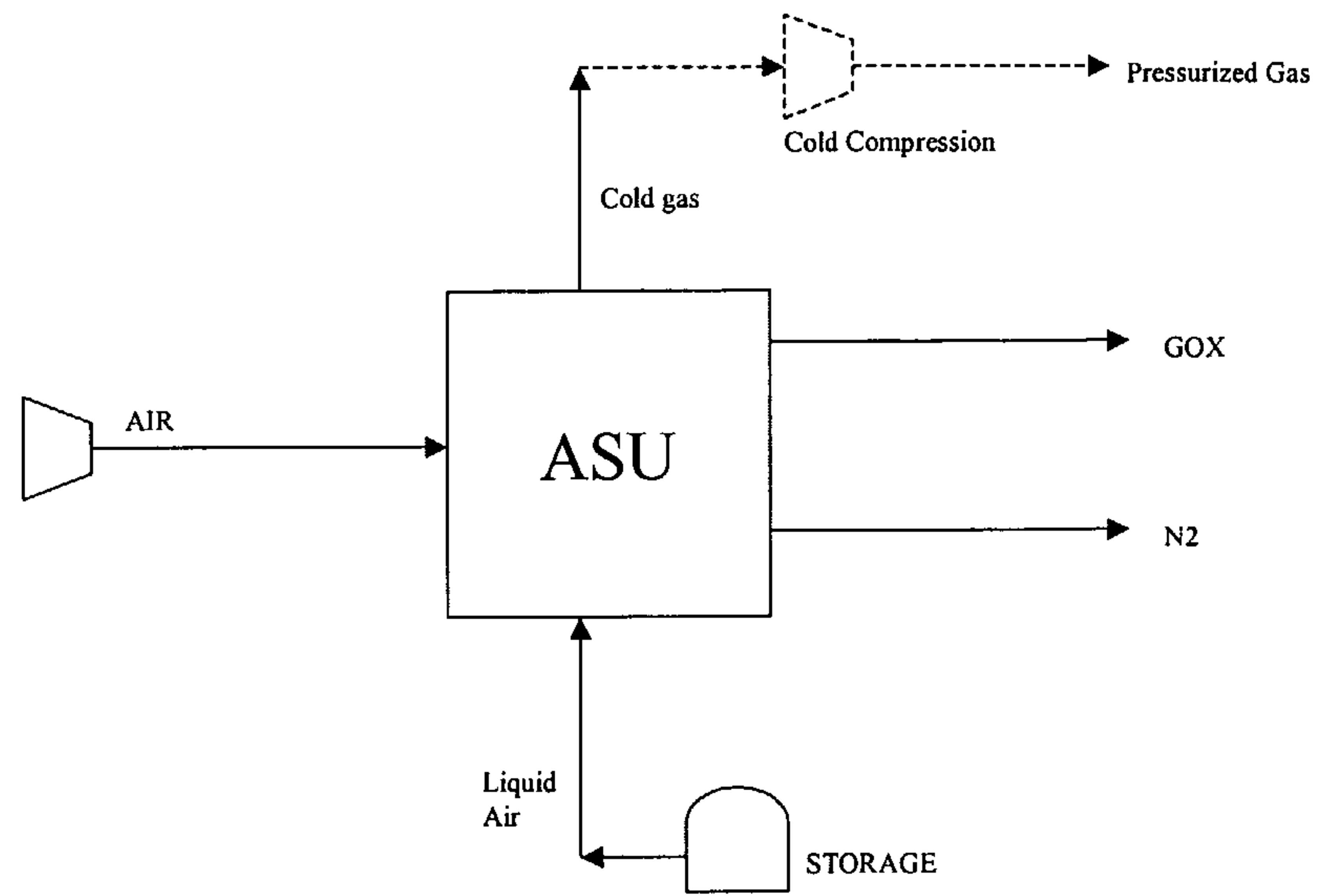

Figure 6

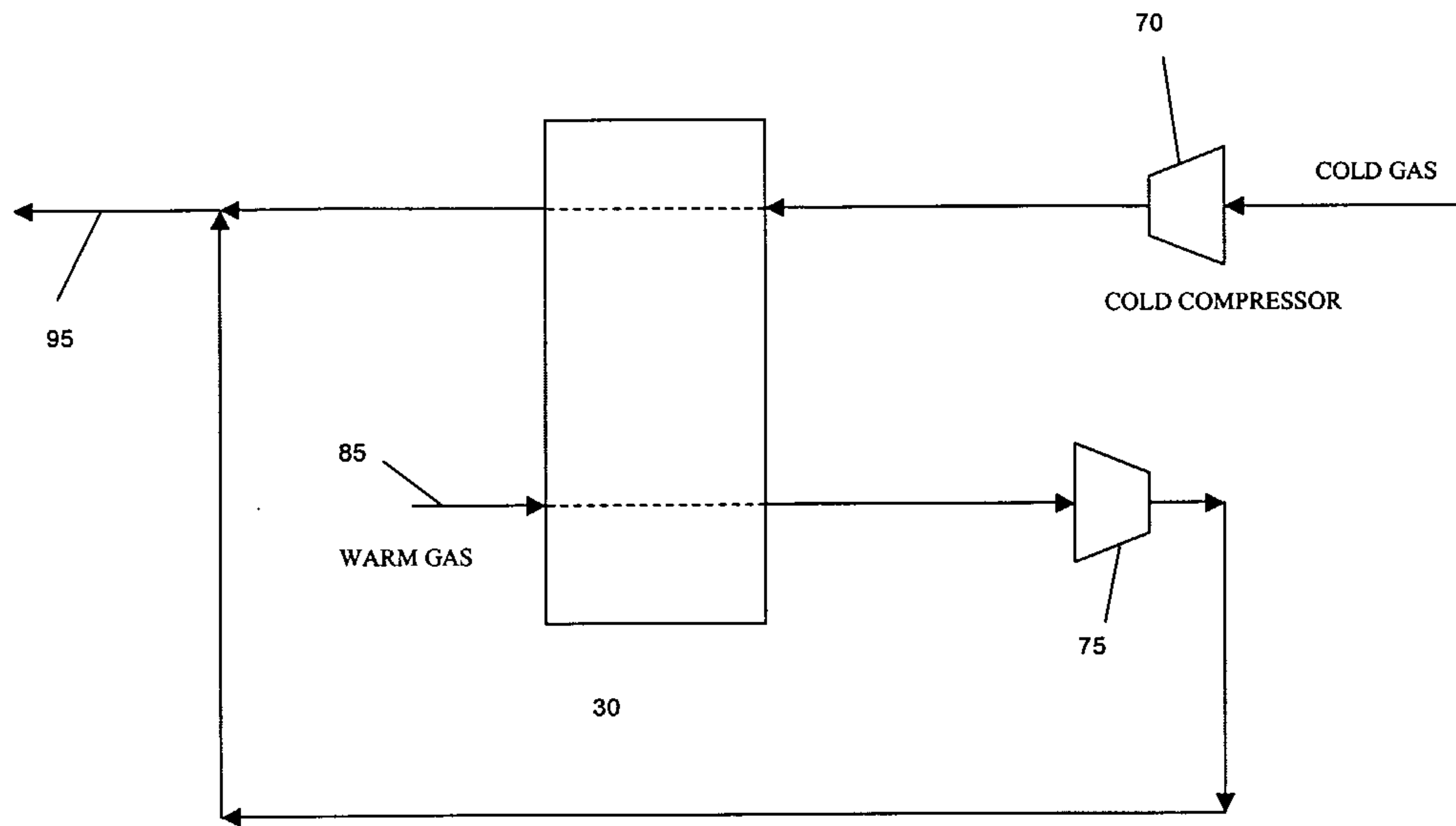

Figure 7

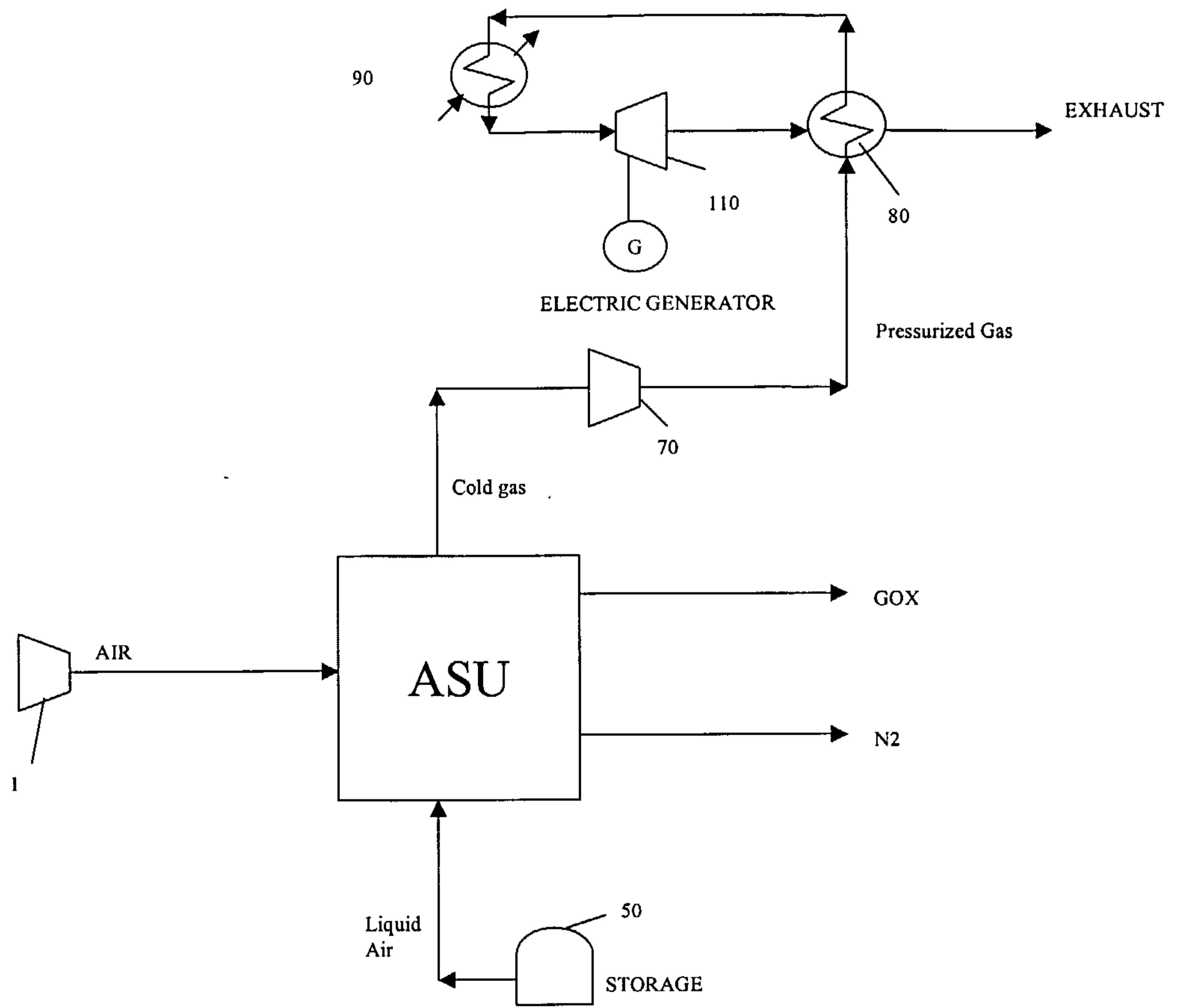

Figure 9

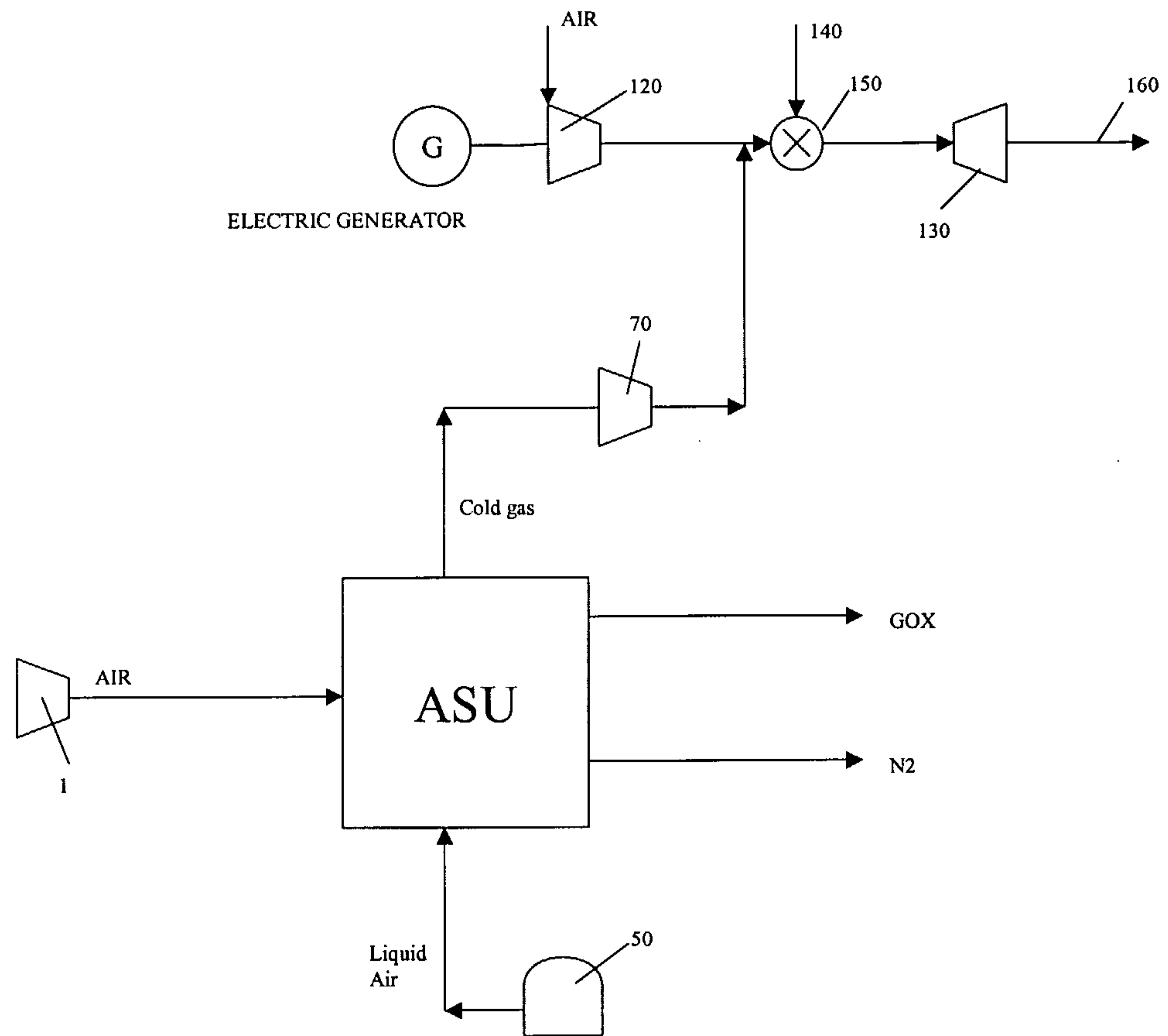

Figure 10

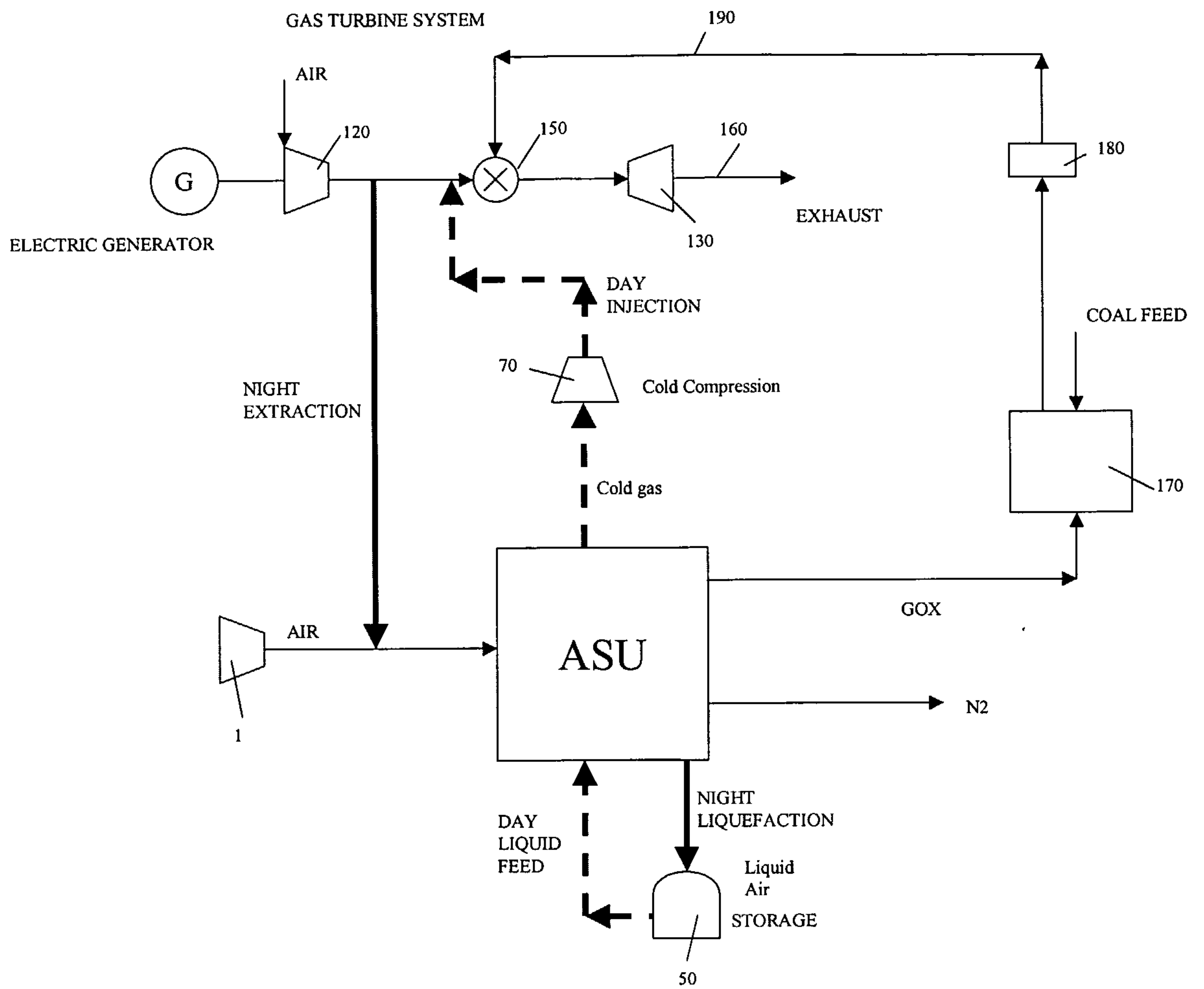

Figure 11

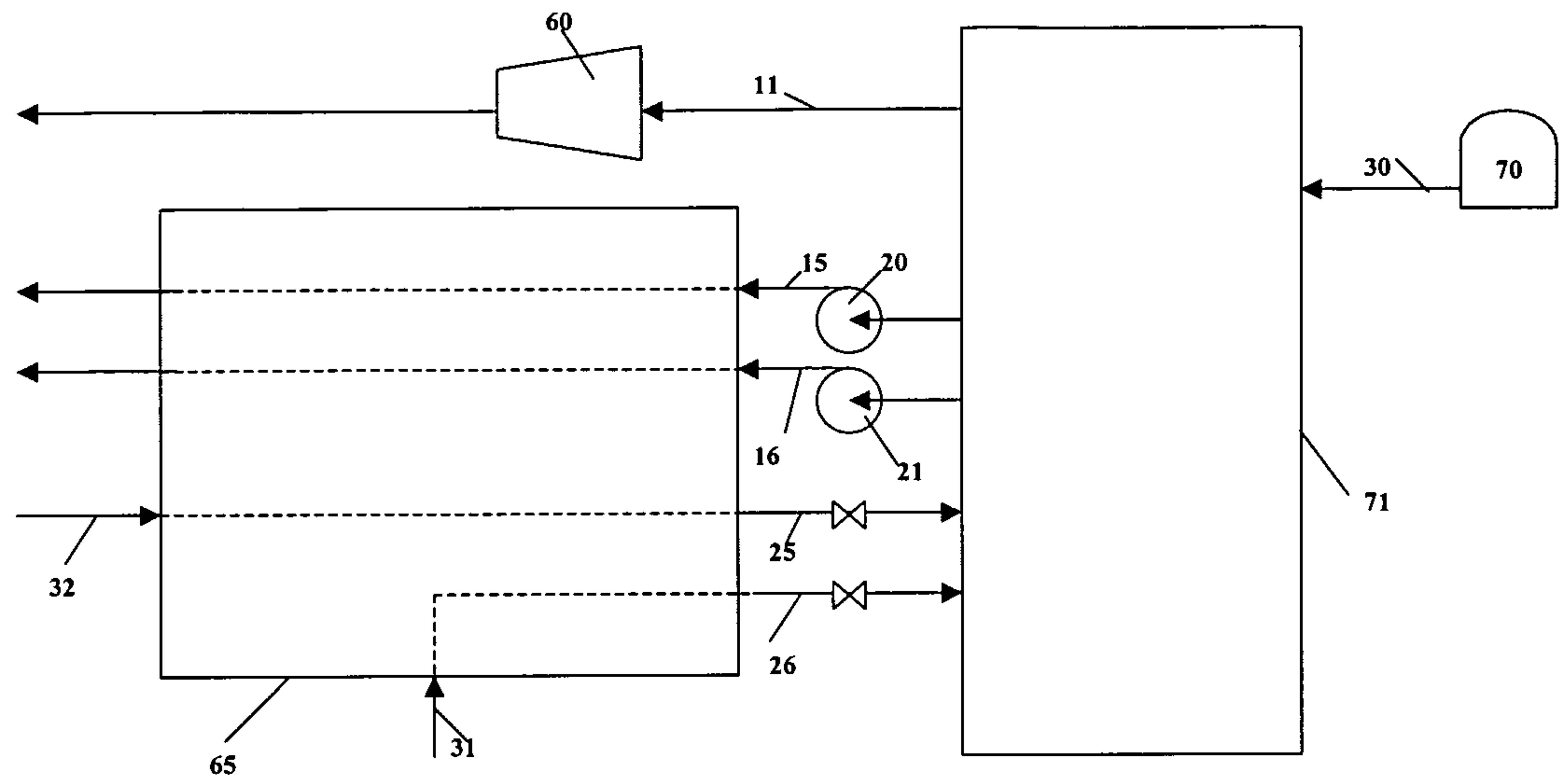

Figure 12

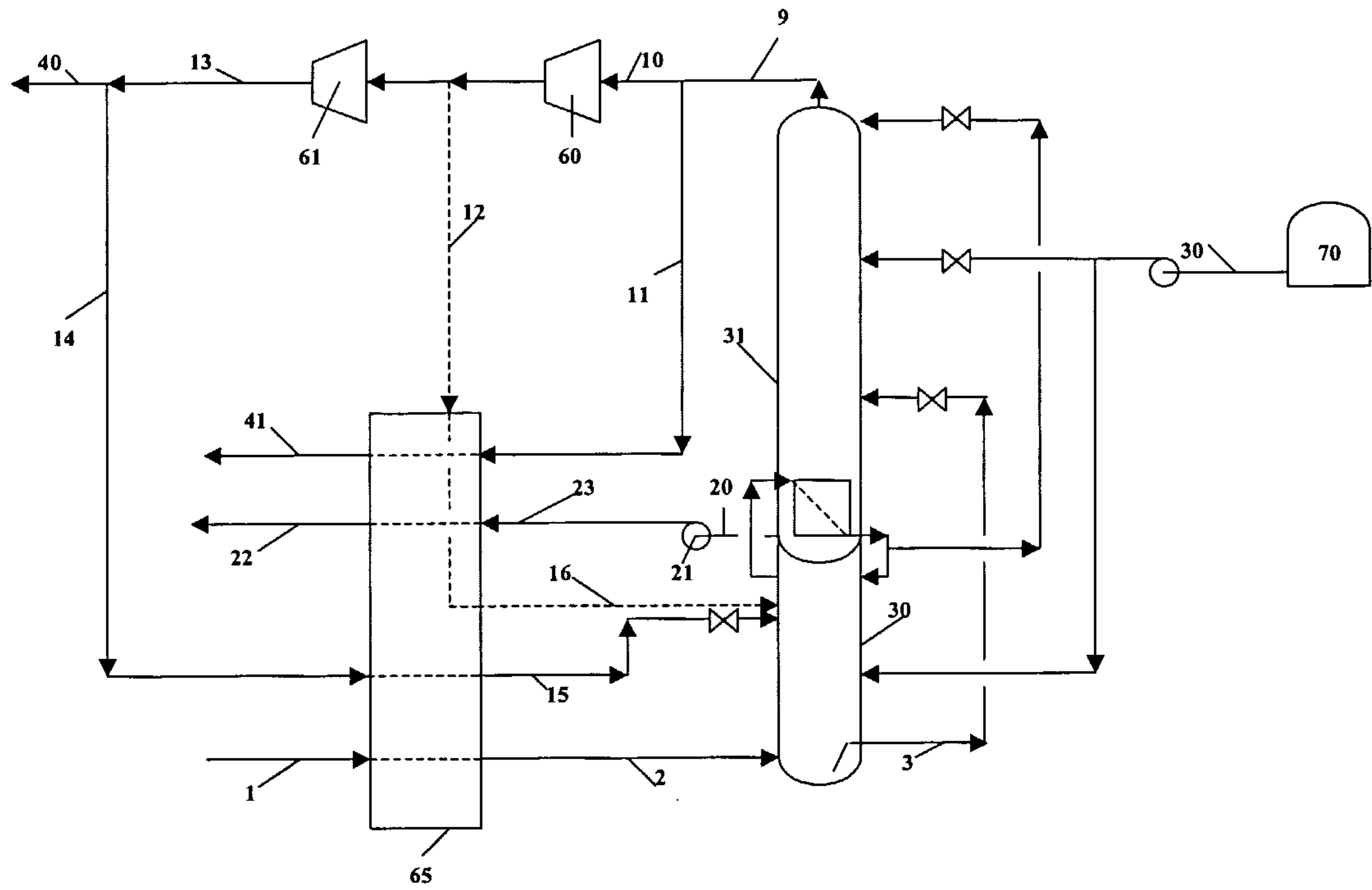

Figure 13

