

(19) World Intellectual Property Organization
International Bureau



(43) International Publication Date
15 April 2010 (15.04.2010)

(10) International Publication Number
WO 2010/042332 A1

(51) International Patent Classification:
B60B 1/00 (2006.01)

(21) International Application Number:
PCT/US2009/058507

(22) International Filing Date:
26 September 2009 (26.09.2009)

(25) Filing Language: English

(26) Publication Language: English

(30) Priority Data:
12/247,830 8 October 2008 (08.10.2008) US

(71) Applicant (for all designated States except US): **LANGFORD IC SYSTEMS, INC.** [US/US]; 310 S. Williams Boulevard, Suite 270, Tucson, AZ 85711 (US).

(72) Inventor; and

(75) Inventor/Applicant (for US only): **LANGFORD, Terrence, R.** [US/US]; 4049 Quiet Moon Drive, Tucson, AZ 85718 (US).

(74) Agent: **MILCZAREK-DESAI, Gavin, J.**; Quarles & Brady LLP, One South Church Avenue, Suite 1700, Tucson, AZ 85701-1621 (US).

(81) Designated States (unless otherwise indicated, for every kind of national protection available): AE, AG, AL, AM, AO, AT, AU, AZ, BA, BB, BG, BH, BR, BW, BY, BZ,

CA, CH, CL, CN, CO, CR, CU, CZ, DE, DK, DM, DO, DZ, EC, EE, EG, ES, FI, GB, GD, GE, GH, GM, GT, HN, HR, HU, ID, IL, IN, IS, JP, KE, KG, KM, KN, KP, KR, KZ, LA, LC, LK, LR, LS, LT, LU, LY, MA, MD, ME, MG, MK, MN, MW, MX, MY, MZ, NA, NG, NI, NO, NZ, OM, PE, PG, PH, PL, PT, RO, RS, RU, SC, SD, SE, SG, SK, SL, SM, ST, SV, SY, TJ, TM, TN, TR, TT, TZ, UA, UG, US, UZ, VC, VN, ZA, ZM, ZW.

(84) Designated States (unless otherwise indicated, for every kind of regional protection available): ARIPO (BW, GH, GM, KE, LS, MW, MZ, NA, SD, SL, SZ, TZ, UG, ZM, ZW), Eurasian (AM, AZ, BY, KG, KZ, MD, RU, TJ, TM), European (AT, BE, BG, CH, CY, CZ, DE, DK, EE, ES, FI, FR, GB, GR, HR, HU, IE, IS, IT, LT, LU, LV, MC, MK, MT, NL, NO, PL, PT, RO, SE, SI, SK, SM, TR), OAPI (BF, BJ, CF, CG, CI, CM, GA, GN, GQ, GW, ML, MR, NE, SN, TD, TG).

Declarations under Rule 4.17:

- as to applicant's entitlement to apply for and be granted a patent (Rule 4.17(ii))
- as to the applicant's entitlement to claim the priority of the earlier application (Rule 4.17(iii))

Published:

- with international search report (Art. 21(3))

(54) Title: APPARATUS AND METHOD FOR REPROCESSING LUMENED INSTRUMENTS

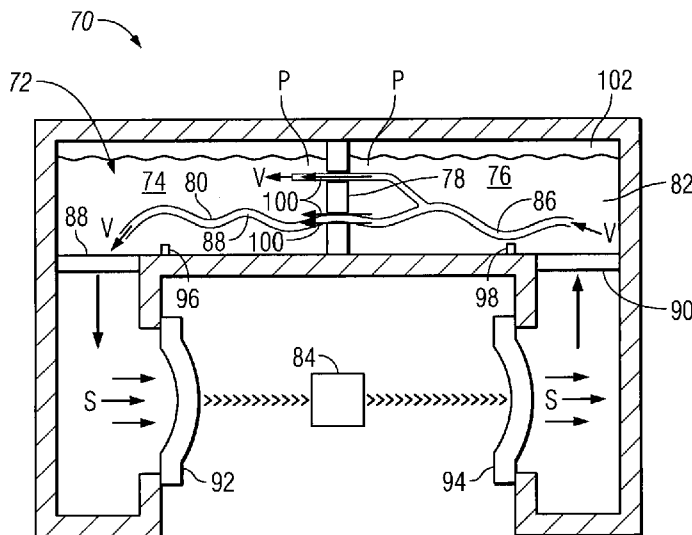

FIG. 8

(57) Abstract: Methods and apparatus for liquid, gas, and gas plasma sterilization of items (Fig. 8). The apparatus includes two chambers and a holder to connectorlessly secure a lumened instrument such that a first portion of the lumened instrument lies in the first chamber and a second portion of the instrument lies in the second chamber, a liquid medium contained within the two chambers, and pumping means for simultaneously increasing fluid pressure within the first chamber of said container while decreasing fluid pressure within the second chamber of the container in a reciprocating fashion. The pumping means displaces at least a total internal volume of the liquid medium through the lumen for a given highest volume of a lumened instrument during each stroke.

WO 2010/042332 A1

APPARATUS AND METHOD FOR REPROCESSING LUMENED INSTRUMENTS

BACKGROUND OF THE INVENTION

5 Field of the Invention

[0001] The invention relates generally to improved apparatus and methods for reprocessing items with lumens, and, more particularly, to apparatus and methods that involve flowing a liquid through a divided chamber containing the item to be cleaned and sterilized.

10 Description of the Related Art

[0002] The reprocessing (i.e., cleaning and decontamination) of items that come into contact with the bodily substances of people or animals such that they are substantially “substance free” (of, e.g., viruses, bacteria, detergent, sterilant, lipids, etc.) represent an immense and ongoing challenge. This challenge has been underscored by a recent
15 article entitled “Widely used sterilizer under attack” (published in January 21, 2003 edition of the newspaper *USA Today*). The article describes a fatal outbreak of bacterial infection that was linked to the improper sterilization of hospital bronchoscopes. Despite the hospital’s use of one of the most popular sterilizing systems, tests performed by the Centers for Disease Control and Prevention found
20 bacteria on the system’s water filters and in its rinse water. This and other infection outbreaks have led to continuing controversy over how best to clean and sterilize used endoscopes. These challenges persist to the present day.

[0003] The contaminants typically found on tubular or “lumened” medical items, such as endoscopes, are especially difficult to remove. In addition to fecal mater, loose
25 cellular debris, blood and blood products, viruses, and bacteria, an endoscope can be coated with various hydrophobic films, such as “biofilm” material. A biofilm typically comprises cells, both dead and alive, cell debris and extracellular polymer substances. Once biofilm is formed by microorganisms (including bacteria, fungi, and protozoans), these microorganisms can colonize and replicate on the interior surfaces of tubing,

forming a protective slime layer known as a "glycocalyx" that is especially difficult to remove.

5 [0004] Merely soaking endoscopes in a sterilant or detergent is unacceptable since numerous pockets exist within the tubing where the sterilant or detergent cannot reach effectively, which leaves areas of contamination within the endoscope. Moreover, with the prevalence of highly contagious diseases such as hepatitis B and C and Acquired Immune Deficiency Syndrome, as well as the pathogens MRSA (Methicillin-resistant Staphylococcus aureus) and *Clostridium difficile*, reliable sterilization or disposal of all used medical tools seemingly becomes mandatory. Yet, while many medical
10 instruments today are routinely cleaned, disinfected, and reused, experts in the field recently have warned that some of the more difficult to clean and sterilize medical items are putting people at risk. For example, the website "myendosite.com" contains scores of recent references involving infection and endoscopy in the news (see myendosite.com/infection_control_media.htm).

15 [0005] Many attempts to improve sterilization apparatus and methods have been tried over the years. For example, a variety of gas sterilization methods has been investigated in the past. Methods using ethylene oxide and other disinfecting gases are widely used for sterilizing a wide range of items, from contact lenses to surgical instruments.

20 [0006] A sterilizing method must effectively kill all organisms, including spores, without damage to the article or goods being sterilized. Moreover, before sterilization can take place, the instrument must be cleaned to the FDA quantifiable validated standard of clean. Indeed, no reprocessor on the market can perform this other than the unique "push/pull reprocessors" created by the inventor and described below.

25 [0007] So-called "push/pull reprocessing systems" are automatic apparatuses that include a chamber containing a baffle with one or more openings through which water (or another fluid) surges in a synchronous fashion back-and-forth (hence "push/pull") through the opening or openings in the baffle. When soiled items, such as endoscopes and other lumened instruments, are placed within an opening in the baffle, fluid also
30 surges upon and through them. Accordingly, a back-and-forth "scrubbing action" is

created by the surging fluid the contacts any accessible surface on an item, including any lumen or lumens.

[0008] For example, U.S. Patent 5,711,921 by Langford discloses a medical apparatus cleaning mechanism that includes a container having a first chamber and a second chamber, with the container adapted to accept a medical instrument such that a first portion of the medical instrument lies in the first chamber and a second portion of the medical instrument lies in the second chamber. Pumping means then simultaneously increase fluid pressure within the first chamber of the container while decreasing fluid pressure within the second chamber until the cycle is reversed, i.e., the fluid pressure in the second chamber increases while the fluid pressure in the first chamber synchronously is decreased.

[0009] While the Langford apparatus is known to provide superb cleaning and sterilization, the teachings of the Langford patent appear limited to the use of the apparatus with a single-size lumen diameter and do not specify how to evacuate the entire lumen volume per each change in fluid flow direction (i.e., a "stroke").

[0010] U.S. Patent No. 6,534,002 by Lin further notes alleged shortcomings of the teachings in Langford as follows: "One significant problem with this surging mechanism for cleaning endoscopes results from the fact that endoscope channels often have different diameters at their opposite ends. As fluid flows from the larger-caliber end of an endoscope channel to the smaller-caliber end, particulate matter and human tissue, secretions, and excrement can become lodged in the smaller-caliber end and extremely difficult to extract. Another problem with the surging mechanism results from the frequent change in directional flow of fluid through the channels of an endoscope. In cleaning an endoscope, debris must travel a long distance, sometimes more than 150 cm, to traverse the length of the endoscope before the debris can exit the endoscope. In surging methods of cleaning endoscopes, some fluid, debris, and air pockets may move back and forth within the endoscope channel, but never travel far enough to exit the channel before the next directional shift in flow occurs. Thus, some debris and air pockets can remain trapped in the central portion of an endoscope channel with the surging method of cleaning."

[0011] The main thrust of how the Lin patent proposes to deal with these shortcomings involves generating a flow of sanitizing solution through a lumened instrument in predominantly one direction, from the smaller-caliber end to the larger-caliber end, to clean or sterilize the inner surface of the device.

5 [0012] However, flowing a fluid in "predominantly one direction" does not necessarily result in better cleaning or sterilizing action; indeed, material may become trapped in complex lumened instruments (such as a restrictor valve in a colonoscope or the spring and guide wire of a biopsy forceps) if a recurring back-and-forth motion is not used to dislodge it.

10 [0013] From the above, it can readily be seen that complex lumened medical devices present unique challenges. Some instruments (e.g., a bronchoscope) have a main lumen of one diameter and another lumen of smaller diameter branching off the main lumen, presenting two resistance ratings inside the same instrument. Furthermore, various lumened instruments have restrictor valves inside the lumen narrowing the fluid path in
15 one direction. This acts as a point of blockage or increased resistance if debris is pushed up against the restrictor. Thus, for those devices that have different size internal lumens in the same instrument, as well as for those that can be 6 feet or longer in length (e.g., a colonoscope), resistance to fluid flow during cleaning and sterilization presents a difficult problem.

20 [0014] Accordingly, it would be desirable to provide an apparatus and method that carry out effective cleaning and sterilization of even complex lumened instruments quickly and thoroughly, while reducing undesirable effects. In addition, it is desirous that the fluid flow about the exterior of a lumened instrument cause sufficient turbulence to clean the outside of the instrument as well.

25

SUMMARY OF THE INVENTION

[0015] The invention generally involves methods and apparatus for reprocessing items with lumens. According to one aspect of the invention, a lumened instrument reprocessing apparatus is provided. The apparatus includes two chambers and a holder

to connectorlessly secure a lumened instrument such that a first portion of the lumened instrument lies in the first chamber and a second portion of the instrument lies in the second chamber, a liquid medium contained within the two chambers, and pumping means for simultaneously increasing fluid pressure within the first chamber of the container while decreasing fluid pressure within the second chamber of said container in a reciprocating fashion. The pumping means is designed to displace at a substantially constant pressure at least a total internal volume of the liquid medium through the lumen for a given highest volume of a lumened instrument during each stroke.

10 **[0016]** According to another aspect of the invention, a method for cleaning or sterilizing a device having a lumen, an inner surface, and an outer surface, involves the steps of a) providing a "push-pull" (i.e., back-and-forth fluid motion) reprocessor having a container including at least one interface that divides the container into two or more chambers; b) securing one or more lumened devices in a connectorless fashion
15 within the interface; c) generating a flow of a fluid from inside the container through the lumen such that fluid corresponding to at least a total internal volume of the lumen is displaced therethrough during each stroke of the reprocessor.

[0017] In another embodiment, an item is cleaned within a push/pull reprocessing apparatus, contained within sterilizable packaging, and sterilized within the
20 reprocessing apparatus through the introduction of a sterilant, the flow of which includes fresh or new sterilant, such as steam, at one or more times during the sterilizing cycle. Thus, a device can be removed from the apparatus in a sterile package, thereby maintaining post-processing sterility.

[0018] In still another embodiment, the invention includes a plasma sterilizer that
25 employs uncharged, highly reactive free radicals, atoms, and excited molecules of a gas mixture to sterilize articles. According to this aspect of the invention, a sterilizer apparatus includes a cleaning and sterilizing chamber, a plasma generating chamber/mixing tank adapted to allow a gas mixture streaming therethrough, means for ionizing the gas mixture in the plasma generating chamber/mixing tank, and a plasma
30 distribution means for distributing downstream plasma gas products to the sterilizing chamber.

[0019] A removable baffle plug of the invention is provided to allow for the placement of different sized items within the baffle, to modulate the pressure between parts of the chamber on either side of the baffle, and to provide information about what is being placed in the chamber through the use of radio frequency identification devices. The plug allows flow between the device being held and the interface, thereby creating a turbulent flow to clean the device exterior in each direction.

[0020] In another embodiment, the pressure within both chambers of the push-pull apparatus is kept substantially constant. For example, the pumping means is used to keep the pressure around 12.5 psi in some embodiments of the invention.

10 [0021] In accordance with the above methods, there is provided new and improved apparatus for sterilizing an item.

[0022] Various other purposes and advantages of the invention will become clear from its description in the specification that follows. Therefore, to the accomplishment of the objectives described above, this invention includes the features hereinafter fully described in the detailed description of the preferred embodiments, and particularly pointed out in the claims. However, such description discloses only some of the various ways in which the invention may be practiced.

BRIEF DESCRIPTION OF THE DRAWINGS

20 [0023] Fig. 1 depicts in a cross-sectional view a “push-pull” reprocessing apparatus of the prior art.

[0024] Fig. 2 schematically illustrates a first apparatus and method embodiment of the invention.

[0025] Fig. 3 schematically illustrates a second apparatus and method embodiment of the invention.

25 [0026] Fig. 4 schematically illustrates a third apparatus and method embodiment of the invention.

[0027] Fig. 5 schematically illustrates an enlarged view of section X taken from Fig. 4.

[0028] Fig. 6 schematically illustrates the same enlarged view as Fig. 5 but with the packaging around the item closed.

5 [0029] Fig. 7 shows a removable baffle plug of the invention.

[0030] Fig. 8 schematically illustrates another embodiment of the invention.

DETAILED DESCRIPTION OF THE PREFERRED EMBODIMENTS

[0031] The terms “push/pull apparatus,” “push/pull system,” “cleaner/sterilizer,”
10 “push/pull reprocessor,” “reprocessor,” and “reprocessing” as used throughout the specification are meant to be synonymous with the use of a push-pull apparatus (such as the Langford IC Systems, Inc. Manzi Mach 1) that cleans items (e.g., endoscopes, dental appliances, surgical instruments and the like) by surging fluid back-and-forth upon the accessible surfaces of these items.

15 [0032] The term “bi-directional” means flowing in two directions at once within the container of the invention.

[0033] As used herein, the term “plasma” is intended to include any portion of the gas or vapors which contains electrons, ions, free radicals, and the like produced as a result of an applied electrical field, including any accompanying radiation that might be
20 produced. While radiation in the radio frequency range is most commonly applied, a broad frequency range may be used.

[0034] Turning to the figures, wherein like numbers designate like features, Fig. 1 depicts a “push-pull” reprocessor of the prior art. An item with a lumen 2 is secured within an opening of a baffle 4 that divides the reprocessor into a first chamber 6 and a
25 second chamber 8. When valves 12 and 14 are opened and diaphragms 10A and 10B are simultaneously activated in opposite directions as shown, fluid F flow through and around the lumen 2. By reversing the direction of the diaphragms 10A and 10B in

unison, a linear or unidirectional flow is created first one way and then the other, resulting in a periodic shear force or “scrubbing action.”

[0035] Fig. 2 illustrates in simple schematic form a first embodiment of the invention. Unlike the linear flow of an initial quantity of “old” sterilant and
5 “push/pull” action created by the apparatus of Fig. 1, this embodiment of the invention bi-directionally flows fresh sterilant into chamber 18. Thus, for example, mixing tank 16 housing gas plasma is distributed into chamber 18 via a pump 20 and a bi-directional valve 22. The bi-directional valve 22 conveys plasma into first chamber 24 and second chamber 26 at the same time, resulting in a bi-directional flow (indicated by
10 arrows 28A and 28B for inflow and arrows 30A and 30B for outflow when the pump is reversed) over item 32 and gas permeable packaging 34. Reversing the pump at desired intervals (e.g., 2 seconds as shown) allows for at least partial evacuation of “old” sterilant while introducing fresh or “new” sterilant upon the item 32.

[0036] While a chamber 18 containing a baffle 36 is shown in this and other
15 embodiments, it should be understood that the invention may include a chamber with no baffle and into which an item is simply placed or secured to a clamp or other structure within the chamber. Moreover, the invention is not limited to gas plasma. Other sterilants may include, for example, ethylene oxide or steam.

[0037] In view of the above apparatus and explanation, a method for sterilizing an
20 item encompasses: placing an item 32 within an opening in baffle 36 such that the item 32 extends into the first chamber 24 and second chamber 26, introducing the sterilant into the first and second chambers such that the sterilant is made to flow bi-directionally (28A, 28B, 30A, 30B) in the chambers, and sterilizing the item while introducing fresh sterilant (symbolized by arrows A and B) into the chamber 18 at least
25 once during a sterilizing cycle.

[0038] The methods of the invention are especially suitable for sterilization of an item inside a gas-permeable sleeve or packaging 34, because the lack of linear flow or substantial “back and forth” motion reduce the chances that the packaging will be damaged or lost (through, for example, being impaled by the item 32 or by sliding off
30 as a result of being pulled in one direction). In the embodiment shown in Fig. 2, this is

accomplished by introducing and evacuating the sterilant on each side of said baffle to provide a continuous bi-directional flow upon item 32.

[0039] In another embodiment of the invention pictured in Fig. 3, gas plasma from tank 16 is alternately introduced on each side of baffle 36 through reversing the one-way pump 40 (during periods in which valve 41 is open). Because sterilant is introduced into only one of chambers 24 or 26 at a time, this embodiment initially appears to provide a “uni-directional” flow of fresh sterilant suitable for sterilizing an item with a lumen. However, as the one-way pump is reversed periodically, the net effect is have gas flowing within the apparatus 18 dynamically to both chambers, with new sterilant being introduced as desired by opening valve 41.

[0040] Fig. 4 illustrates a third embodiment of the invention. Here, the bi-directional flow of sterilant from mixing tank 16 is created by a plurality of pumps 46 and 48. Similar to the one-way pump show in Fig. 3, a net bi-directional flow effect is created by alternating between pump 46 and 48. Moreover, pumps 46 and 48 can be used at the same time to create a “pulsing” effect, whereby waves of fresh sterilant are introduced into chamber 18. The pumps may provide a continuous flow of fresh sterilant or may pump the existing sterilant (though the use of valves or a bypass (not shown) with the mixing tank 16), with new sterilant being introduced as desired.

[0041] In some applications, it may be preferred to dry an item prior to introducing a sterilant. Thus, drying means 47 is connected to chamber 18 to provide heated air. Alternatively, alcohol (e.g., 70% ethanol) or a vacuum can be provided in order to dry item 32.

[0042] Figs. 5 and 6 are greatly enlarged views of section X of Fig. 4. Thus, opening 38 in baffle 36 is more clearly seen. Preferably, the item 32 is contained in a bag 34 having a sealable end 39 (e.g., such as by adhesive) and is placed into opening 38. Also preferably, the item 32 and opening 38 have a “wet fit,” meaning that the friction between the opening and the item is such that fluid (including a gas) can flow between different sides of the baffle 36 as shown by arrow AC.

[0043] To control the flow between different sides of baffle, and to make the baffle adaptable to different sized items, one or more removable plugs may be used with the

invention. Turning to Fig. 7, baffle 50 has a removable plug 52 that is disposed within notch 60 and in sealed arrangement therewith. Thus, plugs with different sized openings 62 may be utilized for different sized items. Moreover, one or more plugs 52 may be removed or filled in to change the flow dynamics between chambers on either
5 side of the baffle.

[0044] Also, radio frequency (RF) transmitters and receivers can be used in conjunction with the plug of the invention. Thus, RF device 70 disposed upon plug 52 can be used to identify a compatible item also containing a RF device. For example, RF device 70 could identify a bronchoscope placed within the opening 62 of plug 52
10 and transmit such information to the operator of the sterilizing apparatus so that a particular program or cycle could be employed.

[0045] The pressure present within a push-pull apparatus during reprocessing operations should be kept substantially constant to avoid collapsing the lumen passage. Moreover, constant pressure during each stroke best ensures that a given flush volume
15 will travel through each lumened instrument every time (i.e., the lumen flush volumes are maximized and consistent for each stroke). However, in view of the variations and complexity of lumened instruments, it can be problematic to thoroughly clean and sterilize them through evacuation of the lumen in both directions at a consistent pressure.

[0046] Previous reprocessor apparatus, such as the FDA cleared Manzi Mach 1 Cleaner Processor System, use a basic control scheme to generate the process pressures that result in fluid flow through instrument lumens. This control scheme employs a reciprocating pump operating at a constant speed. The constant speed control scheme operates the pump at a constant speed independent of the resulting pressure. Thus, the
25 resulting pressure produced is a product of (i) the volume of fluid (ratio of chamber fluid to chamber air) and (ii) the baffle restriction that divides the chamber into two halves. Since the volume of fluid delivered into the chamber can be different from one cycle to the next (this is due, in part, to the available municipal water pressure supplied and the precision of the sensors detecting fluid level), different operating pressures can
30 result.

[0047] This range in chamber operating pressures causes the following: Large chamber structure to account for high pressure, reduced fluid flow through instrument lumen at low pressure, increased fluid flow through instrument lumen at high pressure, and reduced margin on instrument pressure rating. This constant speed control scheme
5 also produces large transient pressures and transient pressure drop-outs which occur due to the fluid dynamics. In other words, there is no active control of the operating pressure.

[0048] Thus, the invention relates to controlling the pressure and amount of fluid that is moved from one side of a divided chamber to the other such that the fluid is in excess
10 of the total internal volume of the lumened instrument(s) being processed. In other words, at least one entire volume is passed through the lumened instrument(s) being processed for every directional change in fluid flow or "stroke" of a push-pull instrument reprocessor. Moreover, each stroke preferably is performed at a constant pressure. Preferably, the total internal volume of a lumened instrument is exceeded by
15 at least 1% to better ensure that any effects on flow dynamics caused by changes in diameter or the presence of other structures inside the lumen are accounted for.

[0049] Thus, the inventor has developed an improvement to the above scheme by actively controlling the operating chamber pressure, thereby producing more consistent flow through instrument lumens and further reducing the possibility of instrument
20 damage. The active pressure control scheme implemented is known as a PID controller (proportional, integral, derivative controller) and can be implemented in hardware or software or a combination. In one embodiment, this improvement is implemented in software.

[0050] The PID software design relies upon acquiring (reading) pressure values from
25 two pressure sensors within the reprocessor container and adjusting the pump rate (speed) so as to cause the pressure to remain within a defined range (target range). The PID controller implements the following:

Proportional (error) = present behavior

$P = (\text{requested pressure} - \text{actual pressure}) / \text{Requested pressure}$

Integral = past behavior

$I = (\text{previous } I) + P$

5 Derivative = future behavior

$D = P - (\text{previous } P)$

⇒ A scaling value is calculated: $S = pScale * P + iScale * I + dScale * D$

Variable	Coefficient
Startup Values	
pScale	0.06
iScale	0.02
dScale	-0.02
Operational Values	
pScale	0.04
iScale	0.02
dScale	-0.03

10 ⇒ The motor speed is adjusted: $\text{Target speed} = \text{Target speed} + S * \text{Target speed}$

[0051] The result of the pressure control algorithm above is that sufficient fluid flow is generated at a controlled (constant or substantially constant) pressure to clean the inside of complex lumened devices of practically any length, even with restrictor valves
 15 in place or guide wires and other similar obstacles to normal fluid flow. Also, by completely evacuating the entire lumen(s) volume every stroke, consistent turbulence is created to clean the outside of the instruments and any other non-lumened instruments placed in the same chamber.

[0052] Turning to the simplified schematic diagram shown in Fig. 8, a reprocessing apparatus 70 is shown that includes a container 72 having a first chamber 74 and a
 20 second chamber 76 that are divided from each other by a holder 78 to connectorlessly secure a multi-branched lumened instrument 80. Ideally, a first portion of the lumened

instrument 80 lies in the first chamber 74 and a second portion lies in the second chamber 76.

[0053] A liquid medium 82 is contained within both chambers of the container and is surged back-and-forth by a pumping means 84 that generate a stroke by simultaneously
5 increasing fluid pressure within the first chamber of while decreasing fluid pressure within the second chamber. The pumping means 84 is controlled to displace at least a total internal volume (V) of the liquid medium 82 through the lumen 86 of instrument 80 during each stroke (even when different diameters are present within the instrument, such as that caused by restrictor valve 88). Thus, for example, a signal is sent to open
10 valves 88 and 90, whereupon pumping means 84 acts upon diaphragms 92 and 94 to generate a stroke (symbolized by arrows S) of fluid flow.

[0054] The pumping means 84 is controlled to generate a substantially constant pressure P within both chambers of the container 72. Preferably, constant pressure of between 1-29 psi is achieved. Pressure is maintained according to pressure sensors 96
15 and 98, which readings from each chamber 74, 76 inform the pumping means to vary its motor speed as needed to ensure that the pressure within each chamber remains substantially constant.

[0055] The instrument 80 preferably has a "wet fit" within the holder 78 that allows flow between the device being held and an opening of the holder, thereby creating a
20 turbulent flow 100 to clean the instrument exterior.

[0056] The inventor has found that not filling the container 72 to the top with fluid 82 results in better cleaning dynamics, particularly of instrument exteriors. Thus, preferably the container 72 includes a volume of air 102 of between 1-25% at the container top (e.g., 95% fluid, 5% air). The inventor has tried air volumes of up to 25%
25 with good results.

[0057] In view of the apparatus shown in Fig. 8, a method for cleaning and/or sterilizing an instrument having a lumen is provided. First, a reprocessor having a back-and-forth motion and including a container having at least one interface that separates the container into two or more chambers or compartments is provided. Next,
30 an instrument is engaged in a connectorless fashion (i.e., its ends are not coupled with a

fitting that shoots fluid within instrument lumen) within an opening in the interface. Then, a flow of a fluid from inside the container is generated through the instrument lumen such that fluid corresponding to at least a total internal volume of the lumen is displaced therethrough during each stroke of the reprocessor. Preferably, the flow
5 exceeds the total internal volume of said lumen by at least 1% to ensure full flow-through of even very complex lumened instruments. Also preferably, the back-and-forth flow of fluid occurs at a substantially constant pressure.

[0058] Within the following examples, endoscopes or other medical or dental instruments will be used as an example of an item or instrument to be reprocessed.
10 However, the inventor contemplates use of the invention with any tubular item, as well as a variety of other items such as circuit boards, cosmetic instruments, food preparation instruments, and other items in which reliable cleaning and sterility are desirable or required.

Example 1

15 [0059] This example utilizes the apparatus shown in Fig. 8. After securing a lumened instrument with baffle fittings designed for different size lumened instruments with one opening of the lumened instrument in one side of the divided container and the other in the other side of the container. Both chambers of the container are filled to 95% of total container volume with filtered water containing an effective amount of a
20 cleaning agent. The reprocessing apparatus is activated and one side is brought to a positive pressure and the other to a negative pressure and reversed for 10 minutes by the pumping means. During each stroke of the reprocessor, a pressure sensor in each chamber of the divided container monitors the pressure and provides feedback used by a controller to adjust the speed of the pumping means such that a substantially constant
25 pressure is maintained at 12.5 psi.

Example 2

[0060] The purpose of this test is to document the results of engineering characterization testing performed on a automatic endoscope reprocessor, the Langford I.C. Systems Sterilizer Cleaner (see U.S. Patent No. 5,906,802 for layout and guidance

in the use of this reprocessor). Testing was performed on a Cleaner, Sterilizer Breadboard.

[0061] The biopsy lumen of three bronchoscopes were loaded with Birmingham Soil (much more than required by FDA test standards) and inoculated with pathogens from an American Society of Test Methods kit. The scopes were left sitting for a 24 hour
5 time period to permit some drying. Using the same Langford I.C. Systems Sterilizer Cleaner liquid-displacement settings as described, each bronchoscope was subjected to one wash cycle at 10 psi for 5 min with a use concentration of 2.5 % of enzymatic cleaner in 10 liters of water. The preferred rate of "liquid displacement" (i.e., the back-
10 and-forth liquid cycling rate in the item-washing chamber of the Sterilizer Cleaner) is 1 gallon per 2 seconds.

[0062] Upon completion of the cleaning cycle, and if gas plasma use is desired, the bronchoscope is dried for 5 minutes with heated air and the sterilization cycle could take place by flowing gas plasma for 5-30 minutes upon the bronchoscope. At least
15 once after the beginning of the sterilizing cycle, fresh gas plasma is pulsed into the chamber to better ensure all surfaces are contacted with active sterilant.

Example 3

[0063] A surgical item is placed in a multi-chamber reprocessor and cleaned as above. The item is then packaged and sealed in a cellulose envelope and transferred to a chamber separate from the cleaning chamber. The separate chamber includes a fluid
20 port to bi-directionally inject gas into the chamber, with a pump alternately applying positive pressure to the chamber and a vacuum to evacuate the chamber. The separate chamber includes radio frequency electrodes to generate the requisite radio frequency signal. The plasma is generated by evacuating the chamber, introducing a gas or
25 vaporized liquid and turning on the power to the electrodes. The plasma is generated in the present process in the same manner as in known prior art plasma sterilization system (e.g., U.S. Patent No. 4,643,876). The surgical item is exposed from 5-30 minutes to the plasma.

[0064] By way of example, hydrogen peroxide is injected in the form of an aqueous
30 solution of hydrogen peroxide containing from about 3% to 20% by weight of

hydrogen peroxide. The concentration of hydrogen peroxide vapor in the chamber may range from 0.05 to 10 mg of hydrogen peroxide per liter of chamber volume. A concentration of 0.125 mg per liter is the minimum preferred concentration of hydrogen peroxide. Air or an inert gas such as argon, helium, nitrogen, neon or xenon may be added to the chamber with the hydrogen peroxide to maintain the pressure in the chamber at the desired level. The hydrogen peroxide solution may be injected in one or more separate injections. Since the hydrogen peroxide is decomposed into non-toxic products during the plasma treatment, no additional steps are required to remove residual hydrogen peroxide from the sterilized object or its packaging prior to use of the object.

[0065] Alternatively, if sterilization of a lumened instrument (e.g., a bronchoscope) is desired, the above method could be modified for use in a push/pull reprocessor to flow gas plasma upon all accessible surfaces, including the exterior and through the lumen of the scope (before or after any packaging of the item takes place). “Unidirectional” flow (with occasional reversal of direction) would be employed to urge the gas plasma (or other vapor-phase sterilants, such as steam) to effectively permeate through the entire lumen.

[0066] Various changes in the details and components that have been described may be made by those skilled in the art within the principles and scope of the invention herein described in the specification and defined in the appended claims. Therefore, while the present invention has been shown and described herein in what is believed to be the most practical and preferred embodiments, it is recognized that departures can be made therefrom within the scope of the invention, which is not to be limited to the details disclosed herein but is to be accorded the full scope of the claims so as to embrace any and all equivalent processes and products. All references cited in this application are hereby incorporated by reference herein.

What is claimed is:

1. A reprocessing apparatus comprising:
 - a) a container having a first chamber and a second chamber, said container having a holder to connectorlessly secure a lumened instrument such that a first portion
5 of said lumened instrument lies in said first chamber and a second portion of said lumened instrument lies in said second chamber;
 - b) a liquid medium contained within said container; and,
 - c) pumping means that generate a stroke by simultaneously increasing fluid
10 pressure within the first chamber of said container while decreasing fluid pressure within the second chamber of said container, wherein said pumping means is controlled to displace at least a total internal volume of said liquid medium through said lumen during each stroke for a given highest volume of a lumened instrument secured in said container.
2. The apparatus of claim 1, wherein said pumping means generate a substantially
15 constant pressure within both chambers of said container.
3. The apparatus of claim 2, wherein said constant pressure is between 1-29 psi.
4. The apparatus of claim 1, wherein said lumened instruments have multiple lumen diameters within said instrument.
5. The apparatus of claim 1, further including a baffle plug that allows flow between
20 the device being held and an opening of the plug, thereby creating a turbulent flow to clean the device exterior.
6. The apparatus of claim 1, wherein said container includes a volume of air of between 1-25% at said container top.
7. A method for cleaning or sterilizing an instrument having a lumen, an inner
25 surface and outer surface, said method comprising the steps of:
 - a) providing a reprocessor having a back-and-forth motion and including a container having at least one interface with an opening, said interface separating said container into two or more compartments;

b) securing said instrument in a connectorless fashion within said interface;
and

c) generating a flow of a fluid from inside said container through said lumen
such that fluid corresponding to at least a total internal volume of said lumen is
5 displaced therethrough during each stroke of said reprocessor.

8. The method of claim 7, where said flow exceeds the total internal volume of said
lumen by at least 1%.

9. The method of claim 7, wherein step c) occurs at a substantially constant pressure.

10. The method of claim 7, wherein said container includes a volume of air of
10 between 1-25% at said container top.

11. The method of claim 7, further including securing said instrument in a baffle plug
that generates a flow between the instrument being held and an opening of the plug,
thereby creating a turbulent flow to clean the instrument exterior.

12. A method for cleaning or sterilizing an instrument with a lumen, an inner surface
15 and outer surface, said method comprising the steps of:

a) providing a reprocessor having a back-and-forth motion and including a
container having at least one interface with an opening, said interface separating said
container into at least two chambers;

b) securing said instrument in a connectorless fashion within said interface
20 such that the instrument is in at least two of said at least two chambers; and

c) generating a flow of a fluid through said lumen at a constant pressure such
that fluid corresponding to at least a total internal volume of said lumen is displaced
therethrough during each stroke of said reprocessor.

13. The method of claim 12, wherein said flow exceeds the total internal volume of
25 said lumen by at least 1%.

14. The method of claim 12, wherein said container includes a volume of air of between 1-25% at said container top.
15. The method of claim 12, wherein step c) is performed at approximately 1-29 psi.
16. The method of claim 12, further including securing said instrument in a baffle
5 plug that generates a flow between the instrument being held and an opening of the
plug, thereby creating a turbulent flow to clean the instrument exterior.

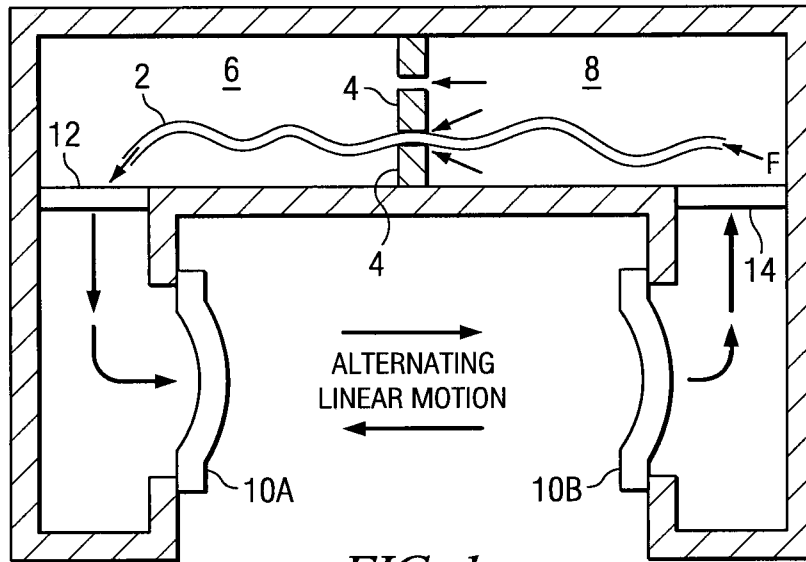

FIG. 1
(PRIOR ART)

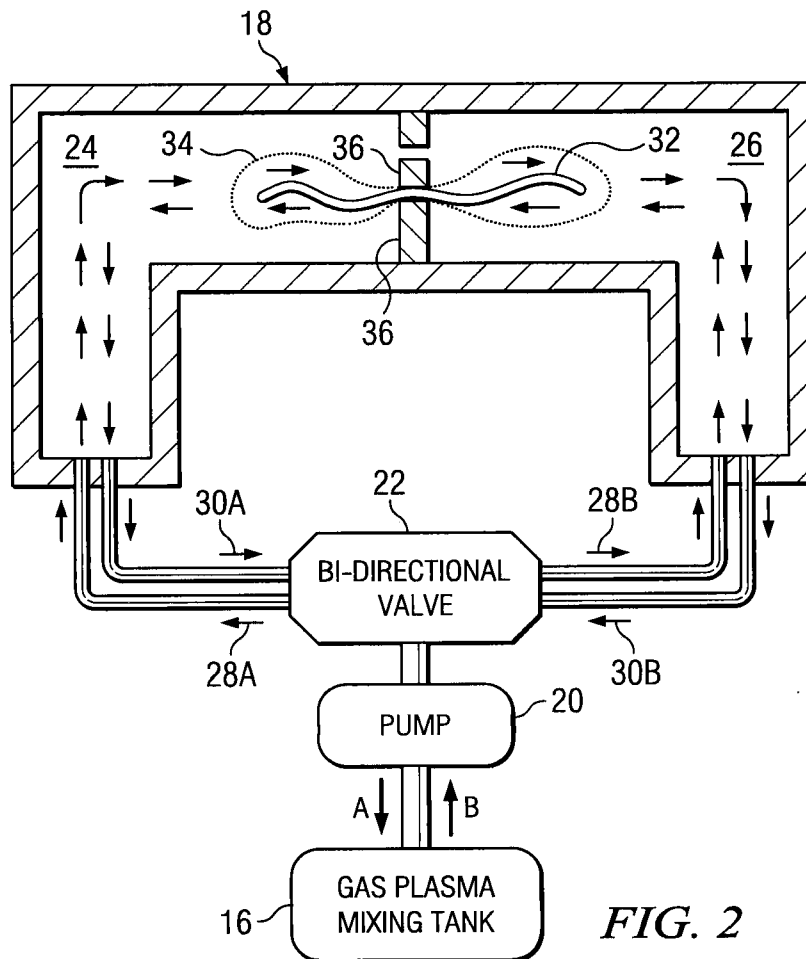

FIG. 2

2/5

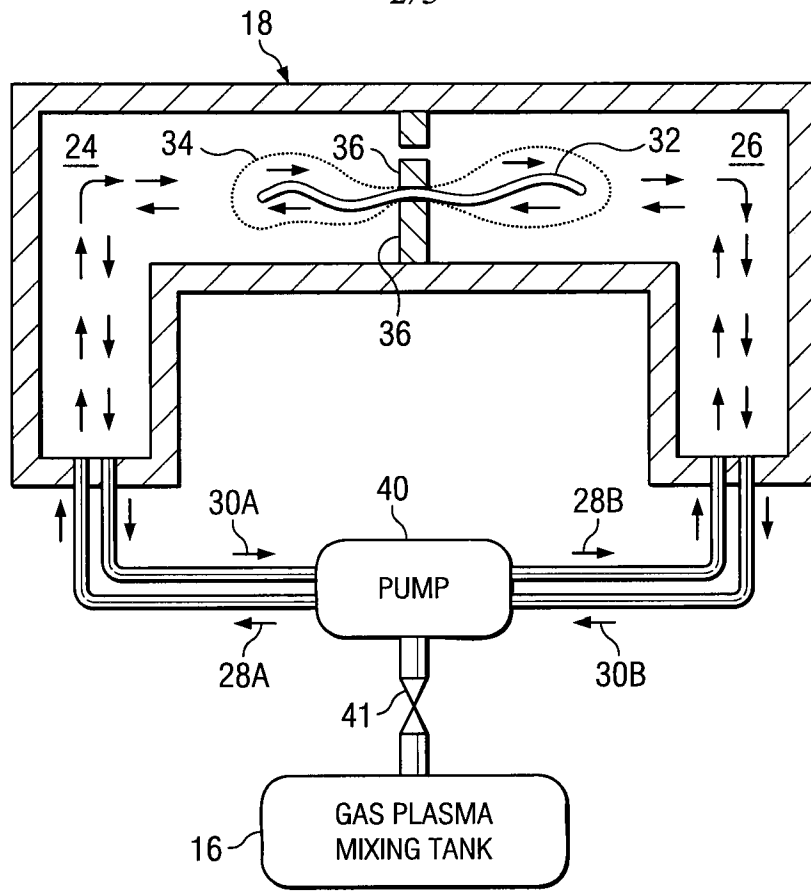

FIG. 3

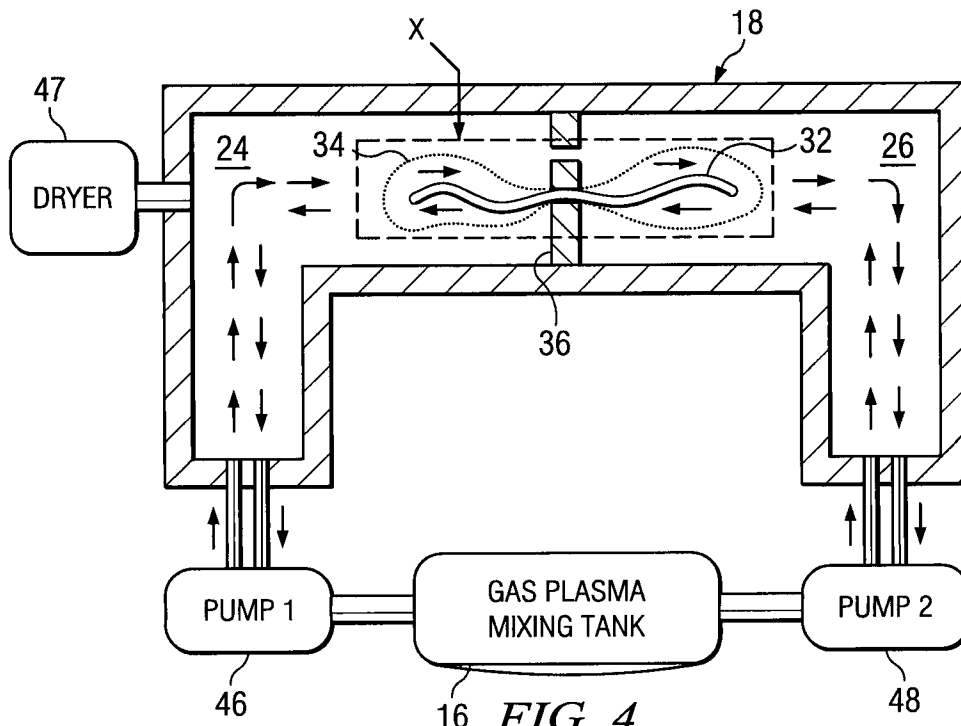
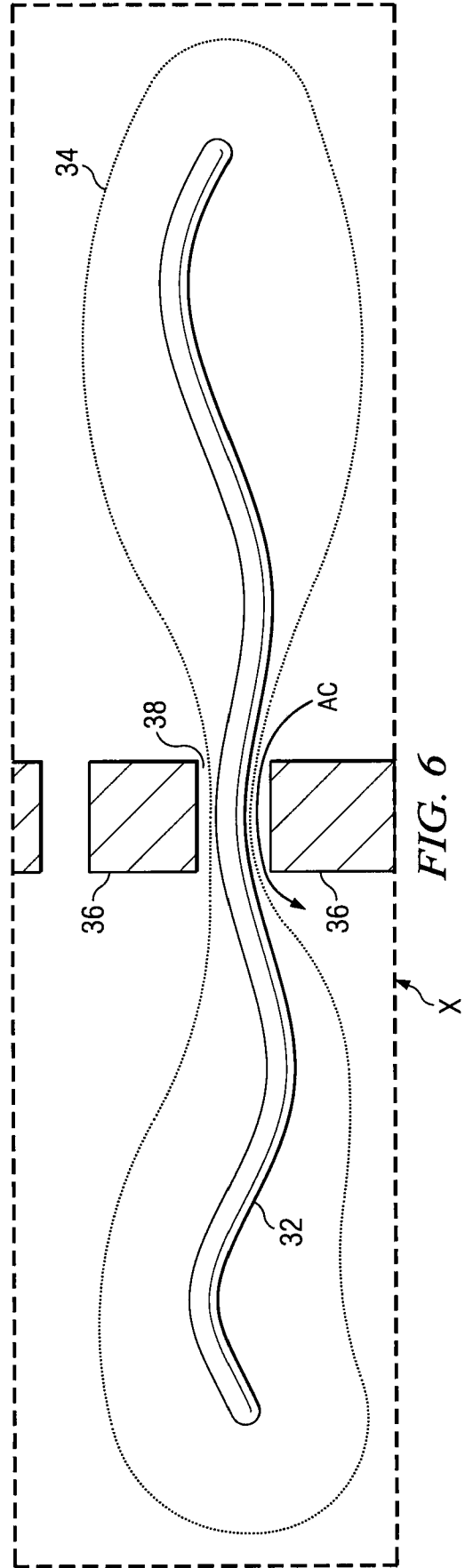
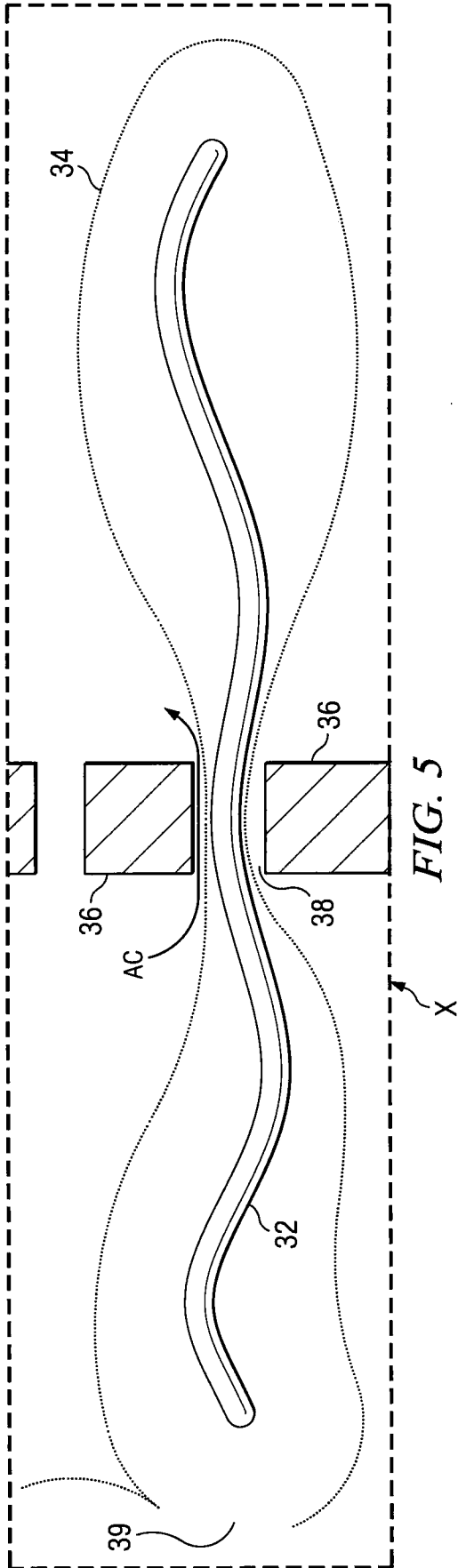

FIG. 4



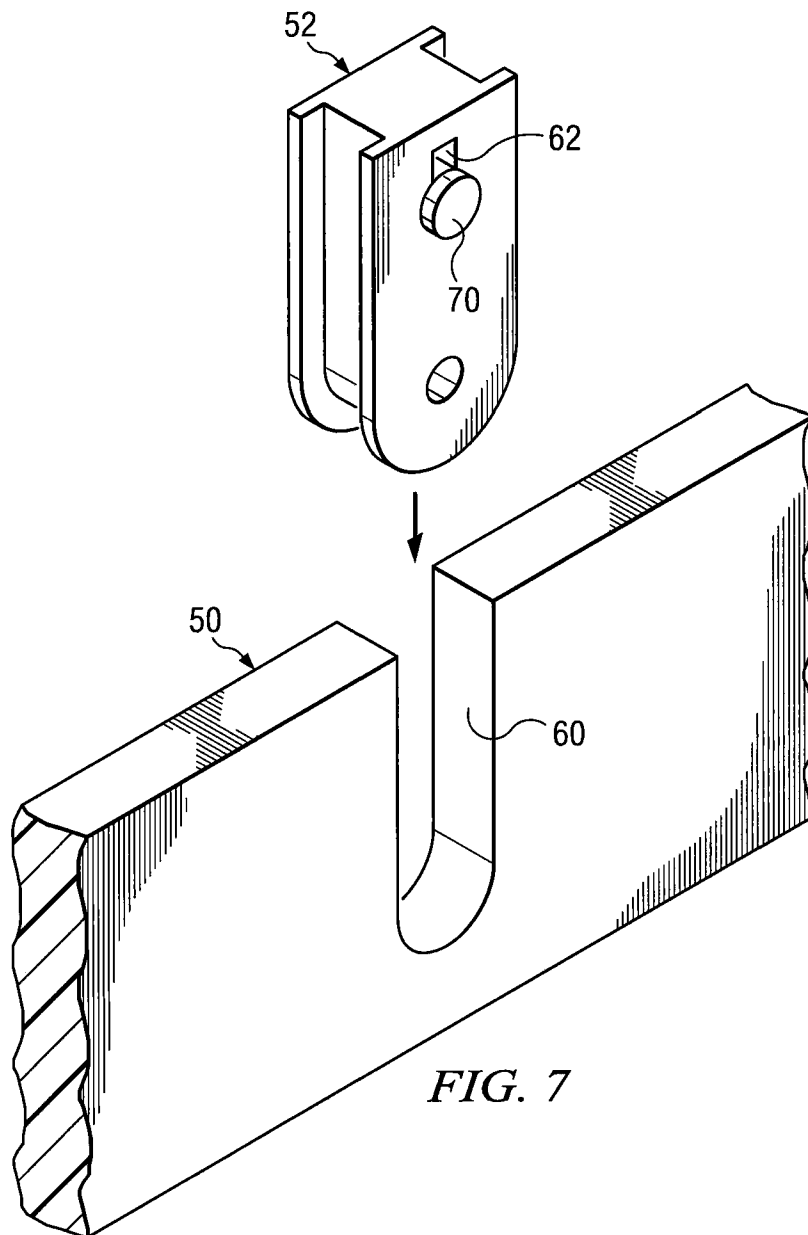

FIG. 7

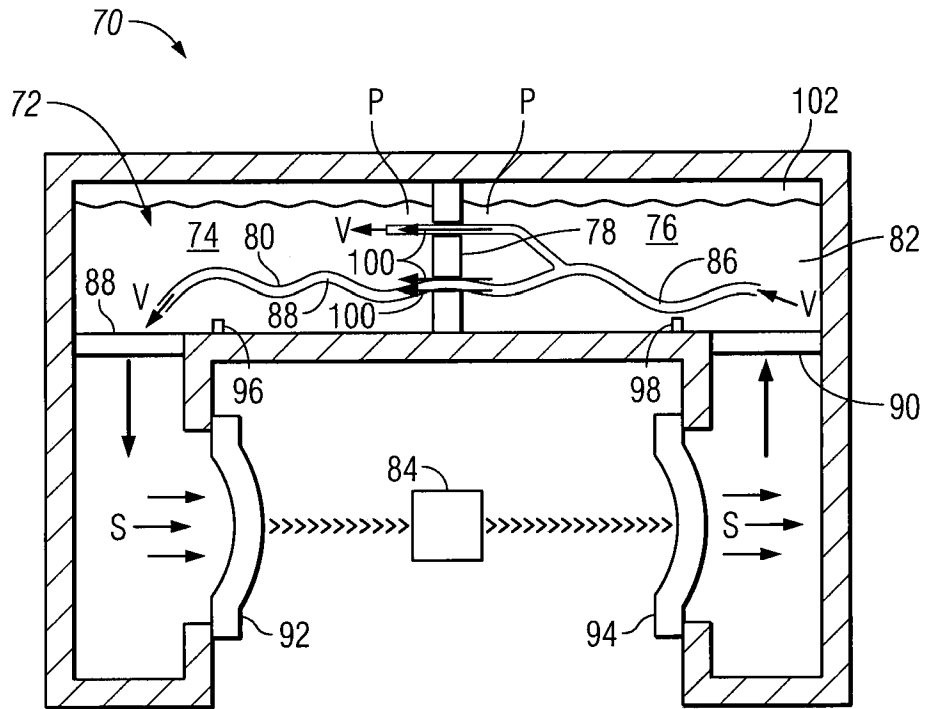

FIG. 8

INTERNATIONAL SEARCH REPORT

International application No.

PCT/US 09/58507

<p>A. CLASSIFICATION OF SUBJECT MATTER IPC(8) - B06B 1/00 (2009.01) USPC - 422/028 According to International Patent Classification (IPC) or to both national classification and IPC</p>												
<p>B. FIELDS SEARCHED</p> <p>Minimum documentation searched (classification system followed by classification symbols) IPC(8) - B06B 1/00 (2009.01); USPC - 422/028</p> <p>Documentation searched other than minimum documentation to the extent that such documents are included in the fields searched</p> <p>Electronic data base consulted during the international search (name of data base and, where practicable, search terms used) PubWEST (PGPB,USPT,EPAB,JPAB), GooglePatents Database, GoogleScholar Database (plasma, gas, liquid, sterilize, lumen, chamber, pump, pressure, stroke, baffle, plug, flow, turbulent, air, displace, chamber)</p>												
<p>C. DOCUMENTS CONSIDERED TO BE RELEVANT</p> <table border="1"> <thead> <tr> <th>Category*</th> <th>Citation of document, with indication, where appropriate, of the relevant passages</th> <th>Relevant to claim No.</th> </tr> </thead> <tbody> <tr> <td>Y</td> <td>US 2007/0207054 A1 (Langford) 6 Sep 2007 (06.09.2007) Figures 2, 7, paragraphs 0020, 0030-0039, 0045-0052</td> <td>1-16</td> </tr> <tr> <td>Y</td> <td>US 5,711,921 A (Langford) 27 Jan 1998 (27.01.1998) column 1, line 62-65, column 3, line 45-58</td> <td>1-16</td> </tr> </tbody> </table>			Category*	Citation of document, with indication, where appropriate, of the relevant passages	Relevant to claim No.	Y	US 2007/0207054 A1 (Langford) 6 Sep 2007 (06.09.2007) Figures 2, 7, paragraphs 0020, 0030-0039, 0045-0052	1-16	Y	US 5,711,921 A (Langford) 27 Jan 1998 (27.01.1998) column 1, line 62-65, column 3, line 45-58	1-16	
Category*	Citation of document, with indication, where appropriate, of the relevant passages	Relevant to claim No.										
Y	US 2007/0207054 A1 (Langford) 6 Sep 2007 (06.09.2007) Figures 2, 7, paragraphs 0020, 0030-0039, 0045-0052	1-16										
Y	US 5,711,921 A (Langford) 27 Jan 1998 (27.01.1998) column 1, line 62-65, column 3, line 45-58	1-16										
<p><input type="checkbox"/> Further documents are listed in the continuation of Box C. <input type="checkbox"/></p>												
<p>* Special categories of cited documents:</p> <table border="0"> <tr> <td>“A” document defining the general state of the art which is not considered to be of particular relevance</td> <td>“T” later document published after the international filing date or priority date and not in conflict with the application but cited to understand the principle or theory underlying the invention</td> </tr> <tr> <td>“E” earlier application or patent but published on or after the international filing date</td> <td>“X” document of particular relevance; the claimed invention cannot be considered novel or cannot be considered to involve an inventive step when the document is taken alone</td> </tr> <tr> <td>“L” document which may throw doubts on priority claim(s) or which is cited to establish the publication date of another citation or other special reason (as specified)</td> <td>“Y” document of particular relevance; the claimed invention cannot be considered to involve an inventive step when the document is combined with one or more other such documents, such combination being obvious to a person skilled in the art</td> </tr> <tr> <td>“O” document referring to an oral disclosure, use, exhibition or other means</td> <td>“&” document member of the same patent family</td> </tr> <tr> <td>“P” document published prior to the international filing date but later than the priority date claimed</td> <td></td> </tr> </table>			“A” document defining the general state of the art which is not considered to be of particular relevance	“T” later document published after the international filing date or priority date and not in conflict with the application but cited to understand the principle or theory underlying the invention	“E” earlier application or patent but published on or after the international filing date	“X” document of particular relevance; the claimed invention cannot be considered novel or cannot be considered to involve an inventive step when the document is taken alone	“L” document which may throw doubts on priority claim(s) or which is cited to establish the publication date of another citation or other special reason (as specified)	“Y” document of particular relevance; the claimed invention cannot be considered to involve an inventive step when the document is combined with one or more other such documents, such combination being obvious to a person skilled in the art	“O” document referring to an oral disclosure, use, exhibition or other means	“&” document member of the same patent family	“P” document published prior to the international filing date but later than the priority date claimed	
“A” document defining the general state of the art which is not considered to be of particular relevance	“T” later document published after the international filing date or priority date and not in conflict with the application but cited to understand the principle or theory underlying the invention											
“E” earlier application or patent but published on or after the international filing date	“X” document of particular relevance; the claimed invention cannot be considered novel or cannot be considered to involve an inventive step when the document is taken alone											
“L” document which may throw doubts on priority claim(s) or which is cited to establish the publication date of another citation or other special reason (as specified)	“Y” document of particular relevance; the claimed invention cannot be considered to involve an inventive step when the document is combined with one or more other such documents, such combination being obvious to a person skilled in the art											
“O” document referring to an oral disclosure, use, exhibition or other means	“&” document member of the same patent family											
“P” document published prior to the international filing date but later than the priority date claimed												
<p>Date of the actual completion of the international search</p> <p>07 Nov 2009 (07.11.2009)</p>		<p>Date of mailing of the international search report</p> <p align="center">17 NOV 2009</p>										
<p>Name and mailing address of the ISA/US</p> <p>Mail Stop PCT, Attn: ISA/US, Commissioner for Patents P.O. Box 1450, Alexandria, Virginia 22313-1450 Facsimile No. 571-273-3201</p>		<p>Authorized officer:</p> <p align="right">Lee W. Young</p> <p>PCT Helpdesk: 571-272-4300 PCT OSP: 571-272-7774</p>										