

J. S. ELLIOTT.

Improvement in Machines for Molding Emery-Wheels.

No. 129,801.

Patented July 23, 1872.

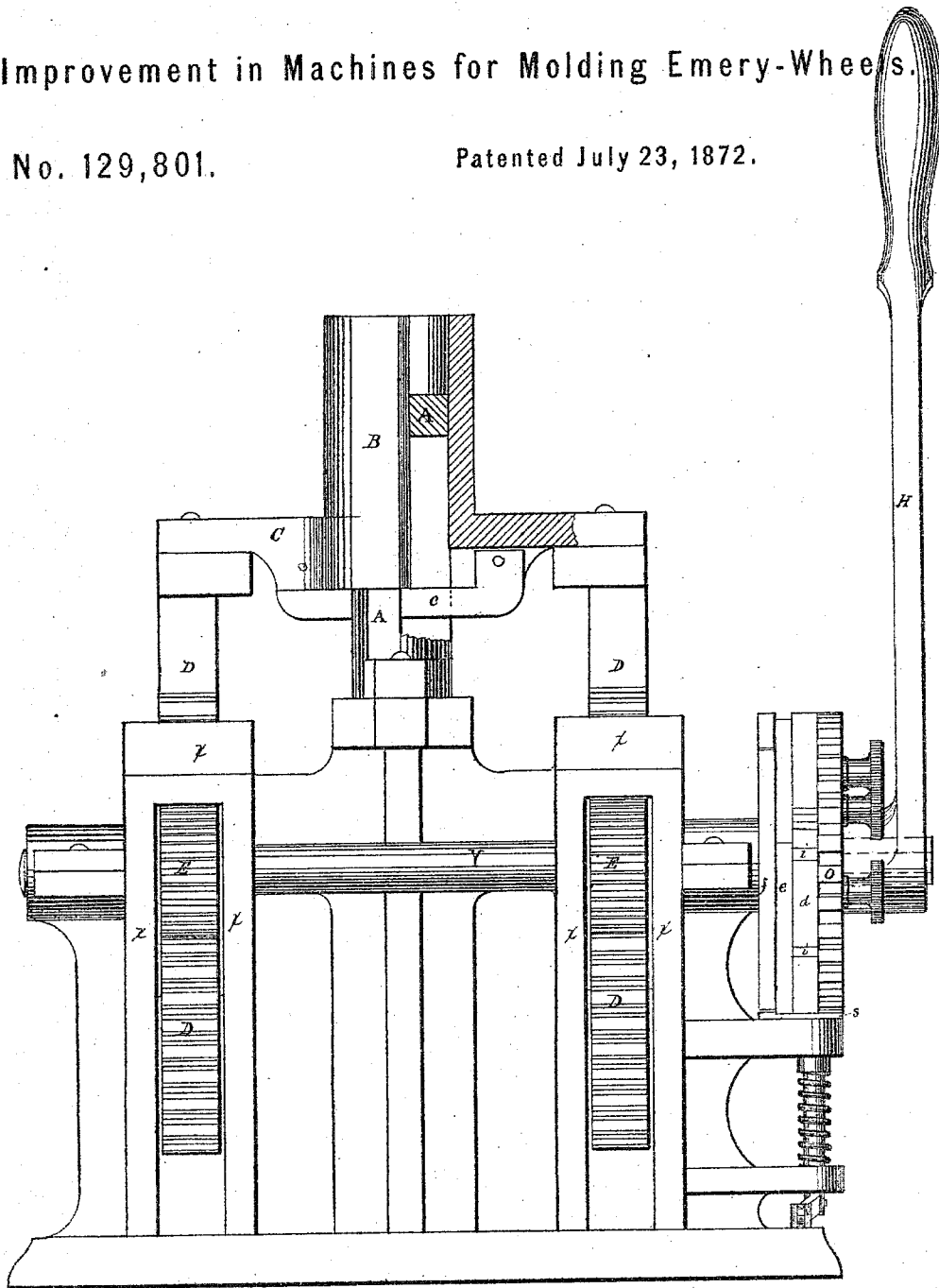

FIG. 1.

WITNESSES.

William W Swan
Chas. P. Gorely.

INVENTOR.

J. S. Elliott

J. S. ELLIOTT.

Improvement in Machines for Molding Emery-Wheels.

No. 129,801.

Patented July 23, 1872.

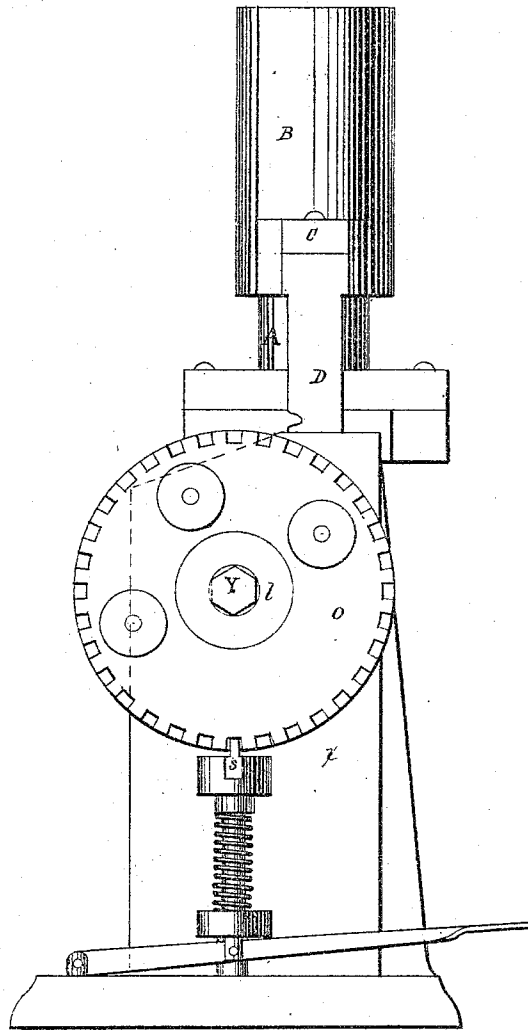

FIG. 2.

WITNESSES.

William W Swan

Chas. P. Gorely

INVENTOR.

J. S. Elliott

J. S. ELLIOTT.

Improvement in Machines for Molding Emery-Wheels.

No. 129,801.

Patented July 23, 1872.

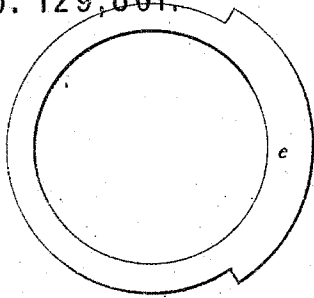

FIG. 9.

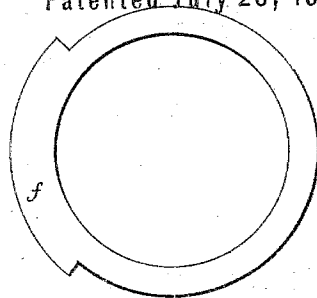

FIG. 8.

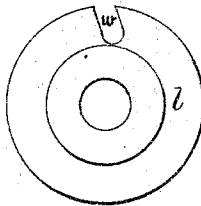

FIG. 10

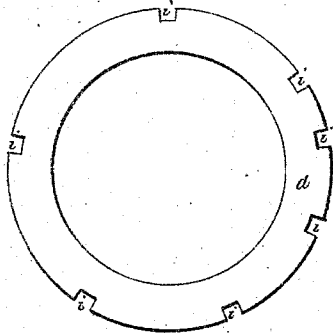

FIG. 7.

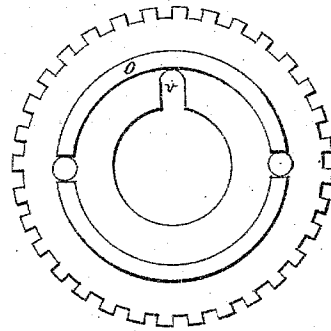

FIG. 6.

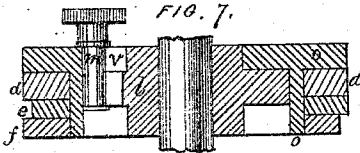

FIG. 5.

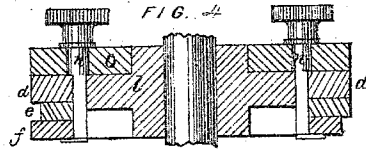

FIG. 4.

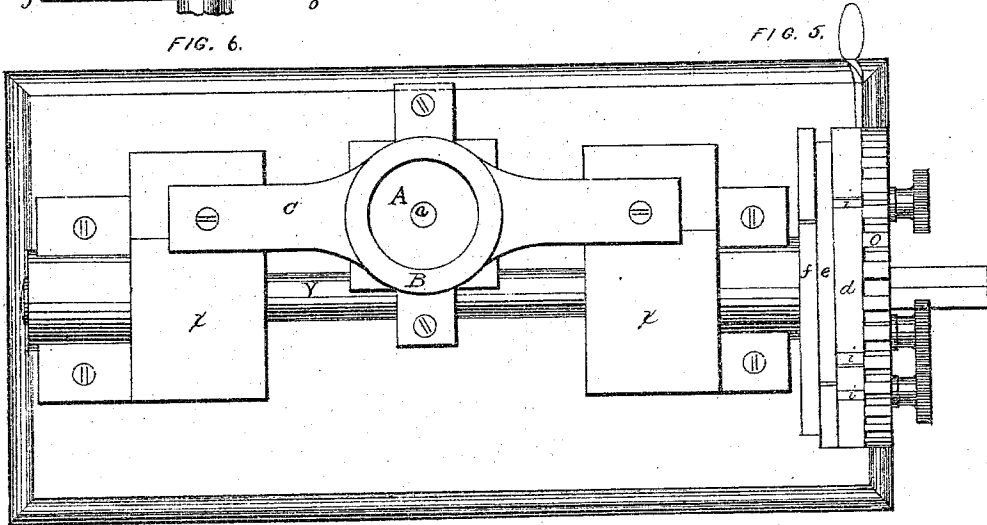

FIG. 3.

WITNESSES.

William W Swan

Chas. P. Corley.

INVENTOR.

J. S. Elliott

UNITED STATES PATENT OFFICE.

JOSIAH S. ELLIOTT, OF CHELSEA, MASSACHUSETTS, ASSIGNOR TO UNION
STONE COMPANY.

IMPROVEMENT IN MACHINES FOR MOLDING EMERY-WHEELS, &c.

Specification forming part of Letters Patent No. 129,801, dated July 23, 1872.

SPECIFICATION.

To all whom it may concern:

Be it known that I, JOSIAH S. ELLIOTT, of Chelsea, in the State of Massachusetts, have invented an Improved Machine for Molding Emery-Wheels and Similar Articles; and I do hereby declare the following to be a full and correct description of the same, reference being had to the accompanying drawing, in which—

Figure 1 is a sectional elevation from the rear of the machine. Fig. 2 is a side elevation. Fig. 3 is a plan. Figs. 4, 5, 6, 7, 8, 9, and 10 are detailed views of the index-wheel and of parts thereof.

The invention consists in the construction of a mold for forming emery-wheels and similar articles, together with suitable mechanism for operating the same, whereby the emery-wheel or other article may be formed in the mold and then removed therefrom, as hereinafter indicated. The invention consists, also, in the construction of mechanism which, by suitable adjustment, regulates the size of the article molded, and insures perfect similarity between all articles intended to be of the same size. It consists, also, in the construction and mode of operation of the index, herein described. It consists, further, in certain details of construction, hereinafter fully set forth.

The invention is herein described as more particularly applicable to molding emery-wheels.

In the drawing, A is a stationary post, the top of which forms the bottom of the mold. B is a cylinder, surrounding and fitting closely the post, and having a vertical movement. At its lowest position its top is flush with the top of the post. When raised it forms the sides of the mold; and the height to which it is raised determines the depth of the mold and the thickness of the emery-wheel formed therein. The cylinder B is firmly secured to a movable cross-piece, C, as shown in Fig. 3. To this cross-piece C is attached a bar, c, which passes through a slot cut through the post A. The slot extends to near the top of the post, as shown in Fig. 1. The bar c has attached to it a pin, a, having also a perpendicular movement through the center of the post A. The top of the pin a is always at the level of the

top of the cylinder B. The pin forms the core of the mold. The cross-piece C, and consequently the cylinder B and pin a, are operated, as indicated in the drawing, by the racks D D and pinions E E. The pinions E E are rigidly secured to the shaft Y, which has bearings, as shown, in the frame of the machine, and is turned back and forth by the lever H. The pinions are covered by casings x x with inclined tops, to prevent the emery-dust and other substances from interfering with the proper action of the racks and pinions, the racks working through slots in the tops of the casings. The shaft Y is likewise protected in its bearings, as shown. The hub of the index-wheel is marked l, and is seen in Figs. 2, 5, and 6. It is of peculiar shape, as shown, that the other parts of the wheel may be so secured to it as to perform their respective offices, and is itself rigidly secured to the shaft Y by a pin, not shown. o is the flanged rim-piece of the index-wheel, also of peculiar shape, as shown in Fig. 6, and fitting closely upon the hub l, to which it is secured by a set-screw, m, passing through the slot v in the rim-piece and a slot, w, in the hub. (See Figs. 4, 6, and 10.) In the flange of the rim-piece o are teeth, by means of which and a catch, s, operated by a spring and treadle, as shown in Fig. 2, the index-wheel is locked in the required positions. The piece o, with the hub, forms the entire face of the index-wheel; the part extending to the rear equals the entire thickness of the wheel. d is a ring, fitting upon the rim-piece o behind its flange, as shown in Fig. 6; it may be called the index-ring, since the depth of the mold is determined by its notches i. e and f are rings having projections, as shown, equal to the length of the teeth of o and the depth of the notches of d, and also fitting upon the rim-piece behind the index-ring, as shown in Fig. 6. The three rings d, e, and f are secured to the piece o by set-screws n n. When the set-screws n n are loosened any or all of these rings may be revolved independently of the hub l and rim-piece o; and the notches in the ring d may be made to coincide with notches in the piece o. The catch s corresponds in length to the thickness of the index-wheel, including the four parts o, d, e, and f; and since the parts o and d have equal radii and their centers coin-

cide, as shown, it is evident that when the catch *s* enters a notch in the piece *o* it must also enter a notch in the ring *d*; it is also evident that the catch cannot enter every notch in *o*, but only such notches as permitted by notches in *d*, which has already been properly designated as the index-ring, since the cylinder B and pin *a* are made to rise and fall according to the distance between two notches selected in *d* for the limits of the movement of the index-wheel. In like manner the true centers of the rings *e* and *f* coincide with the center of *o*, and, by properly turning one or both of them independently of the other parts of the index-wheel, notches in the index-ring *d* may be prevented from receiving the catch *s*, so that any two notches in *d* may be selected to limit the movement of the index-wheel. The device for securing the other parts of the index-wheel to the hub—viz., the set-screw *m*, the radial slot *v*, and the inclined slot *w*—gives to the locking device an adjustment, relatively to the movement of the shaft, more fine than that afforded by the teeth of the wheel.

The operation of the machine is as follows: The top of the cylinder B and the pin *a* being flush with the top of the post A, the parts of the index-wheel are adjusted as previously indicated, two notches in the ring *d* having been selected to determine the depth of the mold, and the catch *s* being permitted to enter one of them and also a corresponding notch in *o*, thereby locking the machine; the operator, then withdrawing the catch by the treadle, turns the lever H until the second selected notch in *d* is reached, thereby forming a mold, as previously indicated, when the catch enters this second notch and a notch in *e* again locking the machine. The operator then forms the emery-wheel in the usual manner. To remove

it from the mold he applies his foot to the treadle and turns the lever back till the index-wheel is locked in its first position, and then takes the emery-wheel from the post A as if from a flat table. To permit molds of different diameters to be used without changing the other mechanism, the cross-piece C should be secured to the rack-bars D D by clamps instead of screws.

With a little variation in the mold the machine may be made to mold articles in various shapes, and will be found especially useful in molding such articles of artificial stone as are made by tamping by hand, whenever it is desirable that two or more articles successively made shall be of the same dimensions.

I claim—

1. In a machine for molding emery-wheels and similar articles, the adjusting mechanism, substantially as herein described, for regulating the size of the article molded.

2. The stationary slotted post A and mold-cylinder B, in combination with bar *c* and pin *a*, constructed and operating substantially as described, for the purpose set forth.

3. The combination of the toothed wheel O, notched index-ring *d*, and rings *e f*, substantially as and for the purpose specified.

4. The toothed wheel O with radial slot *v*, and ring *l* with inclined slot *w*, in combination with set-screw *m*, substantially as and for the purpose stated.

The above specification of my said invention signed and witnessed at Boston this 11th day of April, 1872.

J. S. ELLIOTT.

Witnesses:

WILLIAM W. SWAN,
CHAS. P. GORELY.