

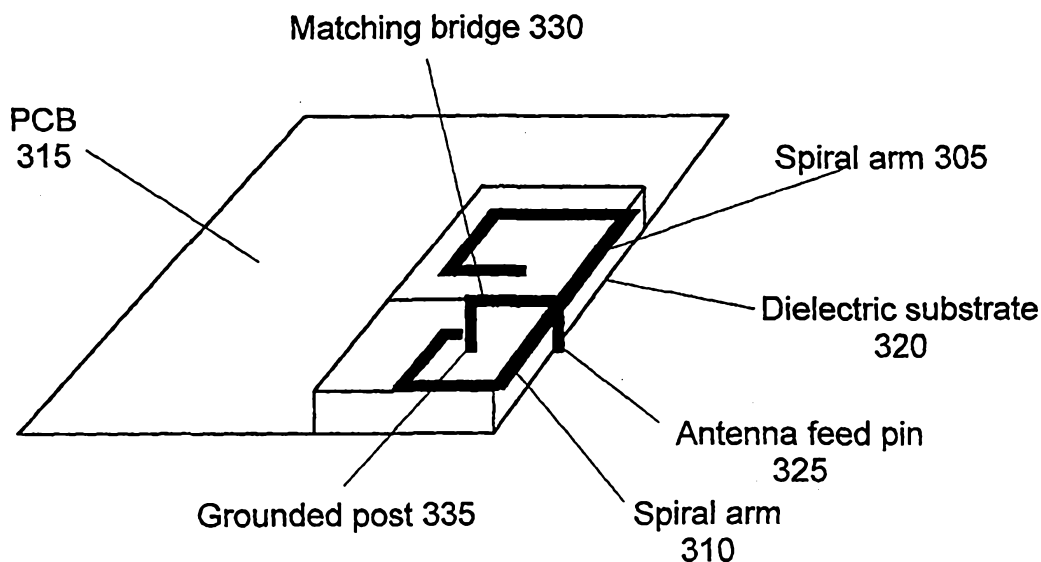

INTERNATIONAL APPLICATION PUBLISHED UNDER THE PATENT COOPERATION TREATY (PCT)

<p>(51) International Patent Classification ⁷ : H01Q 1/24, 9/27, 1/38, 5/00</p>	<p>A1</p>	<p>(11) International Publication Number: WO 00/03452 (43) International Publication Date: 20 January 2000 (20.01.00)</p>
<p>(21) International Application Number: PCT/SE99/01229 (22) International Filing Date: 6 July 1999 (06.07.99) (30) Priority Data: 09/112,152 9 July 1998 (09.07.98) US (71) Applicant: TELEFONAKTIEBOLAGET LM ERICSSON (publ) [SE/SE]; S-126 25 Stockholm (SE). (72) Inventor: YING, Zhinong; Skyttelinjen 50, S-226 49 Lund (SE). (74) Agent: ERICSSON MOBILE COMMUNICATIONS AB; IPR Dept., S-221 83 Lund (SE).</p>	<p>(81) Designated States: AE, AL, AM, AT, AU, AZ, BA, BB, BG, BR, BY, CA, CH, CN, CU, CZ, DE, DK, EE, ES, FI, GB, GD, GE, GH, GM, HR, HU, ID, IL, IN, IS, JP, KE, KG, KP, KR, KZ, LC, LK, LR, LS, LT, LU, LV, MD, MG, MK, MN, MW, MX, NO, NZ, PL, PT, RO, RU, SD, SE, SG, SI, SK, SL, TJ, TM, TR, TT, UA, UG, UZ, VN, YU, ZA, ZW, ARIPO patent (GH, GM, KE, LS, MW, SD, SL, SZ, UG, ZW), Eurasian patent (AM, AZ, BY, KG, KZ, MD, RU, TJ, TM), European patent (AT, BE, CH, CY, DE, DK, ES, FI, FR, GB, GR, IE, IT, LU, MC, NL, PT, SE), OAPI patent (BF, BJ, CF, CG, CI, CM, GA, GN, GW, ML, MR, NE, SN, TD, TG).</p> <p>Published <i>With international search report.</i></p>	

(54) Title: PRINTED TWIN SPIRAL DUAL BAND ANTENNA



(57) Abstract

The present invention overcomes the above-identified deficiencies in the art by providing a miniature, built-in dual band antenna which is suitable for use in future compact mobile terminals. According to exemplary embodiments, a built-in antenna is provided which includes two spiral conductor arms which are of different lengths and capable of being tuned to different frequency bands. The spiral arms are mounted on the mobile terminal's printed circuit board via a substrate. Matching of the antenna is performed by a matching bridge which is positioned between a feeding pin and grounded post. By adjusting the length of the matching bridge, the matching of the antenna can be changed. In an alternative embodiment, a loading resistor is attached to the matching bridge in order to enhance the bandwidth of the antenna.

FOR THE PURPOSES OF INFORMATION ONLY

Codes used to identify States party to the PCT on the front pages of pamphlets publishing international applications under the PCT.

AL	Albania	ES	Spain	LS	Lesotho	SI	Slovenia
AM	Armenia	FI	Finland	LT	Lithuania	SK	Slovakia
AT	Austria	FR	France	LU	Luxembourg	SN	Senegal
AU	Australia	GA	Gabon	LV	Latvia	SZ	Swaziland
AZ	Azerbaijan	GB	United Kingdom	MC	Monaco	TD	Chad
BA	Bosnia and Herzegovina	GE	Georgia	MD	Republic of Moldova	TG	Togo
BB	Barbados	GH	Ghana	MG	Madagascar	TJ	Tajikistan
BE	Belgium	GN	Guinea	MK	The former Yugoslav Republic of Macedonia	TM	Turkmenistan
BF	Burkina Faso	GR	Greece			TR	Turkey
BG	Bulgaria	HU	Hungary	ML	Mali	TT	Trinidad and Tobago
BJ	Benin	IE	Ireland	MN	Mongolia	UA	Ukraine
BR	Brazil	IL	Israel	MR	Mauritania	UG	Uganda
BY	Belarus	IS	Iceland	MW	Malawi	US	United States of America
CA	Canada	IT	Italy	MX	Mexico	UZ	Uzbekistan
CF	Central African Republic	JP	Japan	NE	Niger	VN	Viet Nam
CG	Congo	KE	Kenya	NL	Netherlands	YU	Yugoslavia
CH	Switzerland	KG	Kyrgyzstan	NO	Norway	ZW	Zimbabwe
CI	Côte d'Ivoire	KP	Democratic People's Republic of Korea	NZ	New Zealand		
CM	Cameroon		Republic of Korea	PL	Poland		
CN	China	KR	Republic of Korea	PT	Portugal		
CU	Cuba	KZ	Kazakstan	RO	Romania		
CZ	Czech Republic	LC	Saint Lucia	RU	Russian Federation		
DE	Germany	LI	Liechtenstein	SD	Sudan		
DK	Denmark	LK	Sri Lanka	SE	Sweden		
EE	Estonia	LR	Liberia	SG	Singapore		

PRINTED TWIN SPIRAL DUAL BAND ANTENNA

5

10 BACKGROUND

The present invention relates generally to radio communication systems and, in particular, to built-in antennas which can be incorporated into portable terminals and which allow the portable terminals to communicate within different frequency bands.

15 The cellular telephone industry has made phenomenal strides in commercial operations in the United States as well as the rest of the world. Growth in major metropolitan areas has far exceeded expectations and is rapidly outstripping system capacity. If this trend continues, the effects of this industry's growth will soon reach even the smallest markets. Innovative solutions are required to meet these increasing capacity needs as well as maintain high quality service and avoid rising prices.

20 Throughout the world, one important step in the advancement of radio communication systems is the change from analog to digital transmission. Equally significant is the choice of an effective digital transmission scheme for implementing the next generation technology, e.g., time division multiple access (TDMA) or code division multiple access (CDMA). Furthermore, it is widely believed that the first
25 generation of Personal Communication Networks (PCNs), employing low cost, pocket-sized, cordless telephones that can be carried comfortably and used to make or receive calls in the home, office, street, car, etc., will be provided by, for example, cellular carriers using the next generation digital cellular system infrastructure.

To provide an acceptable level of equipment compatibility, standards have been
30 created in various regions of the world. For example, analog standards such as AMPS (Advanced Mobile Phone System), NMT (Nordic Mobile Telephone) and ETACS and

digital standards such as D-AMPS (e.g., as specified in EIA/TIA-IS-54-B and IS-136) and GSM (Global System for Mobile Communications adopted by ETSI) have been promulgated to standardize design criteria for radio communication systems. Once created, these standards tend to be reused in the same or similar form, to specify additional systems. For example, in addition to the original GSM system, there also
5 exists the DCS1800 (specified by ETSI) and PCS1900 (specified by JTC in J-STD-007), both of which are based on GSM.

However, the most recent evolution in cellular communication services involves the adoption of additional frequency bands for use in handling mobile communications, e.g., for Personal Communication Services (PCS) services. Taking the U.S. as an
10 example, the Cellular hyperband is assigned two frequency bands (commonly referred to as the A frequency band and the B frequency band) for carrying and controlling communications in the 800 MHz region. The PCS hyperband, on the other hand, is specified in the United States to include six different frequency bands (A, B, C, D, E
15 and F) in the 1900 MHz region. Thus, eight frequency bands are now available in any given service area of the U.S. to facilitate communication services. Certain standards have been approved for the PCS hyperband (e.g., PCS1900 (J-STD-007)), while others have been approved for the Cellular hyperband (e.g., D-AMPS (IS-136)).

Each one of the frequency bands specified for the Cellular and PCS hyperbands
20 is allocated a plurality of traffic channels and at least one access or control channel. The control channel is used to control or supervise the operation of mobile stations by means of information transmitted to and received from the mobile stations. Such information may include incoming call signals, outgoing call signals, page signals, page response signals, location registration signals, voice channel assignments,
25 maintenance instructions, hand-off, and cell selection or reselection instructions as a mobile station travels out of the radio coverage of one cell and into the radio coverage of another cell. The control and voice channels may operate using either analog modulation or digital modulation.

The signals transmitted by a base station in the downlink over the traffic and
30 control channels are received by mobile or portable terminals, each of which have at

least one antenna. Historically, portable terminals have employed a number of different types of antennas to receive and transmit signals over the air interface. For example, monopole antennas mounted perpendicularly to a conducting surface have been found to provide good radiation characteristics, desirable drive point impedances and relatively simple construction. Monopole antennas can be created in various physical forms. For example, rod or whip antennas have frequently been used in conjunction with portable terminals. For high frequency applications where an antenna's length is to be minimized, another choice is the helical antenna.

As described above, it will soon be commercially desirable to offer portable terminals which are capable of operating in widely different frequency bands, e.g., bands located in the 900 MHz region and bands located in the 1800 MHz region. Accordingly, antennas which provide adequate gain and bandwidth in both frequency bands will need to be employed in portable terminals in the near future. Several attempts have been made to create such dual-band antennas.

For example, U.S. Patent No. 4,571,595 to Phillips et al. describes a dual-band antenna having a sawtooth-shaped conductor element. The dual-band antenna can be tuned to either of two closely spaced apart frequency bands (e.g, centered at 915 MHz and 960 MHz). This antenna design is, however, relatively inefficient since it is so physically close to the chassis of the mobile phone.

Japanese patent no. 6-37531 discloses a helix which contains an inner parasitic metal rod. In this patent, the antenna can be tuned to dual resonant frequencies by adjusting the position of the metal rod. Unfortunately, the bandwidth for this design is too narrow for use in cellular communications.

Dual-band, printed, monopole antennas are known in which dual resonance is achieved by the addition of a parasitic strip in close proximity to a printed monopole antenna. While such an antenna has enough bandwidth for cellular communications, it requires the addition of a parasitic strip. Moteco AB in Sweden has designed a coil matching dual-band whip antenna and coil antenna, in which dual resonance is achieved by adjusting the coil matching component ($\frac{1}{4} \lambda$ for 900 MHz and $\frac{1}{2} \lambda$ for 1800 MHz). This antenna has relatively good bandwidth and radiation performances and a length in

the order of 40mm. A non-uniform helical dual-band antenna which is relatively small in size is disclosed in copending, commonly assigned patent application no. 08/725,507, entitled "Multiple Band Non-Uniform Helical Antennas."

Presently, antennas for radio communication devices, such as mobile phones,
5 are mounted directly on the phone chassis. However, as the size and weight of portable terminals continue to decrease, the above-described antennas become less advantageous due to their size. Moreover, as the functionality of these future compact portable terminals increases, the need arises for a built-in miniature antenna which is capable of being resonant at multiple frequency bands.

10 Conventional built-in antennas currently in use in mobile phones include microstrip antennas and planar inverted-F antennas. Microstrip antennas are small in size and light in weight. The planar inverted-F antenna (PIFA) has already been implemented in a mobile phone handset, as described by K. Qassim, "Inverted-F Antenna for Portable Handsets", IEE Colloquium on Microwave Filters and Antennas
15 for Personal Communication Systems, pp.3/1-3/6, Feb.1994, London, UK. And, more recently, Lai et al. has published a meandering inverted-F antenna (WO 96/27219). This antenna has a size which is about 40% of that of the conventional PIFA antenna.

Figures 1A and 1B illustrate the conventional planar patch antenna compared to the meandering inverted-F antenna described in Lai et al. The conventional planar
20 patch antenna of Figure 1A has both a size and length equal to, for example, a quarter wavelength of the frequency to which the antenna is to be made resonant. The conventional planar patch antenna also has a width W . The meandering inverted-F antenna, illustrated in Figure 1B, also has a length equal to a quarter wavelength of the resonant frequency and a width equal to W ; however, the size of the meandering
25 inverted-F antenna is reduced to about 40% of the size of the conventional planar patch antenna. This reduction in size is attributable to the antenna's meandering shape.

However, as mobile phones become smaller and smaller, both conventional microstrip patch and PIFA antennas are still too large to fit the future small phone chassis. Moreover, these built-in antennas are not capable of being tuned to dual

frequency bands. Such a capability will be necessary for next generation phones which need multiple antennas for cellular, wireless local area network, GPS and diversity.

SUMMARY

5 The present invention overcomes the above-identified deficiencies in the art by providing a miniature, built-in dual band antenna which is suitable for use in future compact mobile terminals. According to exemplary embodiments, a built-in antenna is provided which includes two spiral conductor arms which are of different lengths and capable of being tuned to different frequency bands. The spiral arms are mounted on
10 the mobile terminal's printed circuit board via a substrate. Matching of the antenna is performed by a matching bridge which is positioned between a feeding pin and grounded post. By adjusting the length of the matching bridge, the matching of the antenna can be changed. In an alternative embodiment, a loading resistor is attached to the matching bridge in order to enhance the bandwidth of the antenna. The antenna of
15 the present invention is of a printed twin-spiral design, is very small in size (the size is less than 1/10 of the wavelength at the operating frequency which results in an antenna which is 20-30% of the conventional PIFA antenna), dual band, and surface mountable.

20 BRIEF DESCRIPTION OF THE DRAWINGS

The above objects and features of the present invention will be more apparent from the following description of the preferred embodiments with reference to the accompanying drawings, wherein:

25 Figures 1A and 1B illustrate the conventional planar patch antenna compared to the conventional meandering inverted-F antenna;

 Figure 2 illustrates a radio communication device in which the antenna of the present invention may be implemented;

 Figure 3 illustrates the built-in multiple band spiral antenna according to a first embodiment of the present invention;

Figure 4 illustrates a top view of the built-in multiple band spiral antenna of the present invention;

Figure 5 illustrates the built-in multiple band spiral antenna according to a second embodiment of the present invention;

5 Figure 6 illustrates a simulation result of a GPS/ISM-link dual band antenna of the present invention; and

Figure 7 illustrates a simulation result of a GSM/DCS dual band antenna of the present invention.

10 DETAILED DESCRIPTION

Figure 2 illustrates a radio communication device 200 in which the built-in multiple band antenna of the present invention may be implemented. Communication device 200 includes a chassis 210 having a microphone opening 220 and speaker opening 230 located approximately next to the position of the mouth and ear,
15 respectively, of a user. A keypad 240 allows the user to interact with the communication device, e.g., by inputting a telephone number to be dialed. The communication device 200 also includes a built-in antenna assembly 250, the details of which will be described below.

Figure 3 illustrates the built-in antenna assembly according to an exemplary
20 embodiment of the present invention. The built-in antenna assembly, according to the present invention, comprises two conductor arm 305 and 310, each of which is configured in an inner spiral shape. The two conductor arms 305 and 310 are attached to the printed circuit board (PCB) 315 via a dielectric substrate 320 and are connected at a joint connection point to a feeding pin 325. The spiral conductor arms are
25 positioned over the PCB 315 and form slots between the conductor arms and the PCB 315. One skilled in the art will appreciate that the spiral slots form the main radiators (or sensors) of the present antenna system.

As evident from Figure 3 and more clearly illustrated in the top view of Figure 4, the conductor arms 305 and 310 are fed by the feeding pin 325 at the end of the
30 outer turn of the spirals. One skilled in the art will appreciate that the current in the

conductor arms decays as it travels from the feeding pin to the other end of the conductor arms. As a result, the antenna has higher radiation efficiency when the currents are distributed mostly in the outer edge of the conductor arms.

The built-in antenna also includes a matching bridge 330 positioned between the feeding pin 325 and the grounded post 335. The matching bridge 330 acts to tune the antenna and forms a small loop antenna between the feeding pin 325 and grounded post 335. Tuning of an antenna refers to matching the impedance seen by an antenna at its input terminals such that the input impedance is seen to be purely resistive, i.e., it will have no appreciable reactive component. The tuning of the antenna system of the present invention is performed by measuring or estimating the input impedance associated with an antenna and providing an appropriate impedance matching circuit (i.e., the matching bridge). The matching of the antenna, according to the present invention, can be adjusted by changing the length of the matching bridge 330. This is accomplished by simply changing the location of the grounded post 335. The length of the matching bridge is generally in the order of 0.01λ to 0.1λ .

It is evident from Figures 3 and 4 that the two conductor arms 305 and 310 of the antenna system are of different lengths. This allows the antenna system to operate in multiple frequency bands, as will be described in more detail below. By controlling the lengths of the conductor arms, the antenna is capable of being tuned to different frequencies. The first arm of the multiple band antenna 305 is of a length (generally a quarter wavelength of the frequency band to which the arm is to be tuned) and construction so as to be resonant at frequencies in a first lower band, and the second arm 310 is of a length and construction so as to be resonant at frequencies in a second higher band. The two arms can be made resonant at any frequency.

For example, the first band may be the GSM band and the second band may be the DCS band. As such, the first arm is approximately $1/4$ wavelength of a GSM signal (i.e., 900 MHz), and the second arm is approximately $1/4$ wavelength of a DCS signal (i.e., 1800 MHz). This allows the antenna to be easily tuned to dual resonances. While the present example sets forth that the first and second bands are GSM and DCS bands, respectively, one skilled in the art will appreciate that other combinations of

frequency bands may be implemented without departing from the spirit and scope of the present invention. For example, other possible combinations of low and high bands could include GSM+PCS, GSM+WCDMA, DCS+WCDMA, GSM+GPS, GSM+ISM, or any other combination of lower and higher frequency bands.

5 The multiple band antenna can be manufactured as printed metal strips, a wire structure or etched onto a plastic frame. While the conductor arms are illustrated as being configured in an inner spiral shape, one skilled in the art will appreciate that other shapes could alternatively be chosen, such as a meandering or outer spiral shape. The inner spiral configuration, however, provides not only for a reduction in the
10 overall size of the antenna (about 20% of the size of the conventional planar patch antenna), but also, as described above, higher efficiency.

 The resonant frequencies and bandwidth of the built-in multiple band antenna of the present invention are dependent upon the area and thickness of the dielectric substrate, the type of dielectric material selected (i.e., the dielectric constant), the
15 spiral length and the rate of expansion of the spiral. One skilled in the art will appreciate that an increase in the area or thickness of the dielectric substrate or tightness of the spiral or a decrease in the value of the dielectric constant results in an increase in the bandwidth which can be achieved.

 As is evident from Figure 3, the built-in multiple band antenna of the present
20 invention can be mounted at the edge of the PCB which provides for better radiation efficiency and bandwidth. In addition, the PCB space requirement for the built-in multiple band antenna is minimized due to its small size.

 The antenna assembly of the present invention works as a magnetic antenna. As a result, the spiral metal strip creates nearly circular polarized waves (as opposed to
25 linear polarized waves achieved by the conventional antennas described above with respect to Figures 1A and 1B) when the rate of expansion of the spiral (i.e., the tightness of the spiral) is chosen properly. This would be advantageous in a multipath environment, such as mobile radio communications, and in satellite (e.g., GPS) communications where circular polarized signals are generally used. Moreover, as a
30 magnetic antenna, there is less interference from the human body.

Figure 5 illustrates the built-in spiral antenna according to a second embodiment of the present invention. One skilled in the art will appreciate that a printed antenna on a ground plane has a narrower bandwidth than the bandwidth of the earlier-described conventional monopole or dipole antenna. The bandwidth of such a printed antenna
5 can be enhanced by introducing some loss to the system. This is evident from the fact that loss always indicates a lower Q-factor and thus a higher bandwidth. The following equation illustrates the relationship between the Q-factor and the achievable bandwidth:

$$Q = f_0 / BW$$

10 where f_0 is the center frequency and BW is the bandwidth.

According to an exemplary embodiment of the present invention, a loading resistor 560 is connected in series to the matching bridge 330 in order to introduce loss into the system. In the alternative, the same result can be achieved by connecting the resistor 560 in parallel to the grounded post 335. The resistor of the present invention
15 can be either a chip resistor or a resistor film. The resistor introduces loss in the antenna's radiated power which results in broader bandwidth.

The resistor value can be selected in order to satisfy particular design requirements. In a situation where high efficiency is needed (i.e., loss is to be kept small), a small resistor value should be used. However, in a situation where a wide
20 bandwidth is critical, a larger resistor value should be used.

In order to illustrate the effectiveness of the present invention, Figures 6 and 7 set forth results of simulations for exemplary dual band antennas. The antennas in both simulations are mounted on a printed circuit board via a dielectric substrate. In the first simulation, the results of which are illustrated in Figure 6, the dual band, twin
25 spiral antenna has a length of 0.1 wavelength, a width of 0.05 wavelength and a height of 0.04 wavelength. The arms of the antenna are made resonant at the GPS and ISM frequency bands. The bandwidth of the antenna is 6.8% (i.e., about 107MHz) at the GPS band and 4.5% (i.e., about 110MHz) at the ISM band for a VSWR less than 2.5:1. Figure 6 illustrates the VSWR performance of the antenna of the present
30 invention for the first simulation. It is evident from Figure 6 that, since GPS requires

a narrow band, it is possible to provide an even smaller antenna than that used in the simulation.

In the second simulation, the conductor arms of the antenna are made resonant at the GSM and DCS frequency bands. The dual band, twin spiral antenna has a length
5 of 0.1 wavelength, a width of 0.07 wavelength and a height of 0.04 wavelength. In this simulation, a one ohm chip resistor is attached to the matching bridge in order to enhance the antenna's bandwidth. The bandwidth is 8.7% (i.e., about 80MHz) at the GSM band and 8.8% (i.e., about 160MHz) at the DCS band for a VSWR less than 2.5:1. Figure 7 illustrates the VSWR performance of the antenna of the present
10 invention for the second simulation.

The foregoing has described the principles, preferred embodiments and modes of operation of the present invention. However, the invention should not be construed as being limited to the particular embodiments discussed above. For example, while the antenna of the present invention has been discussed primarily as being a radiator,
15 one skilled in the art will appreciate that the printed, twin spiral, dual band antenna of the present invention would also be used as a sensor for receiving information at specific frequencies. Thus, the above-described embodiments should be regarded as illustrative rather than restrictive, and it should be appreciated that variations may be made in those embodiments by workers skilled in the art without departing from the
20 scope of the present invention as defined by the following claims.

WHAT IS CLAIMED IS:

1. A communication device for use in a radio communication system, said device comprising:
 - a microphone opening for allowing the communication device to receive auditory information from a user;
 - a speaker opening for allowing the communication device to transmit auditory information to said user;
 - a keypad; and
 - a multiple band antenna comprising a first arm and a second arm tuned to different frequency bands;wherein said multiple band antenna is a built-in antenna.
2. The communication device of claim 1 wherein said first arm is resonant at frequencies in a lower band and said second arm is resonant at frequencies in a higher band.
3. The communication device of claim 1 wherein a shape of said first and second arms is one of an inner spiral, outer spiral and meandering shape.
4. The communication device of claim 1 further comprising a matching bridge for matching an input impedance of said antenna.
5. The communication device of claim 4 wherein the matching of said antenna is adjusted by changing a length of the matching bridge.
6. The communication device of claim 1 wherein said first and second arms are shaped as inner spirals and currents in said first and second arms are fed at an end of an outer turn of said spirals.

7. The communication device of claim 1 further comprising a printed circuit board onto which said built-in multiple band antenna is mounted.

8. The communication device of claim 1 wherein lengths of said arms are selected to be approximately $1/4$ wavelength of the different frequency bands to which the arms are to be tuned.

9. The communication device of claim 4 further comprising a loading resistor attached to said matching bridge for enhancing a bandwidth of said antenna.

10. A communication device for use in a radio communication system, said device comprising:

a printed circuit board mounted on a chassis of said communication device;

a substrate attached to said printed circuit board and having a predetermined thickness; and

an antenna mounted on said substrate and comprising first and second spiral arms which are resonant at different frequencies

wherein said antenna is a built-in antenna.

11. The communication device of claim 10 wherein said first arm is resonant at frequencies in a lower band and said second arm is resonant at frequencies in a higher band.

12. The communication device of claim 10 further comprising a matching bridge for matching an input impedance of said antenna and located between a feeding point and a ground post.

13. The communication device of claim 12 wherein the matching of said antenna is adjusted by changing a length of the matching bridge.

14. The communication device of claim 10 wherein lengths of said arms are selected to be approximately $1/4$ wavelength of the different frequency bands to which the arms are to be tuned.

15. The communication device of claim 12 further comprising a loading resistor attached to said matching bridge for enhancing a bandwidth of said antenna.

16. The communication device of claim 10 wherein a bandwidth of said antenna depends on a size of said spiral arms and the thickness and dielectric constant of said substrate.

17. An antenna for a radio communication device, said antenna comprising:
two printed spiral arms each of which is tuned to a different frequency band;
wherein said antenna is a built-in antenna.

18. The antenna of claim 17 wherein a first arm of said antenna is resonant at frequencies in a lower band and a second arm of said antenna is resonant at frequencies in a higher band.

19. The antenna of claim 18 wherein said first arm is longer than said second arm.

20. The antenna of claim 17 further comprising:
a matching bridge for matching an input impedance of said antenna; and
a loading resistor attached to the matching bridge for enhancing a bandwidth of the antenna.

21. The antenna of claim 20 wherein the matching of said antenna is adjusted by changing a length of the matching bridge.

22. The antenna of claim 17 wherein said printed spiral arms are connected to a printed circuit board of said radio communication device via a substrate.

23. The antenna of claim 22 wherein a bandwidth of said antenna is dependent on a size of said printed spiral arms and a thickness and dielectric constant of said substrate.

24. The antenna of claim 17 wherein currents in said printed spiral arms are fed at an end of an outer turn of said spirals.

1/7

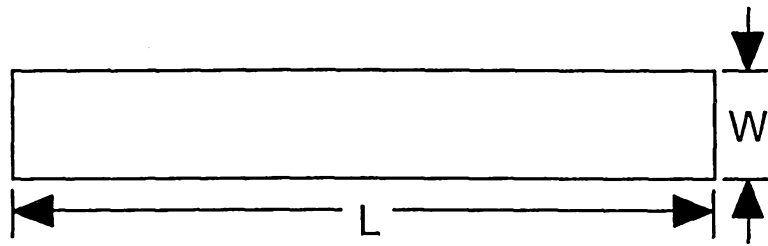

FIG. 1A

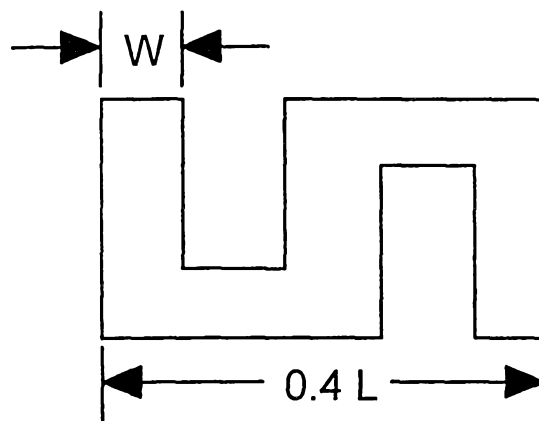

FIG. 1B

2/7

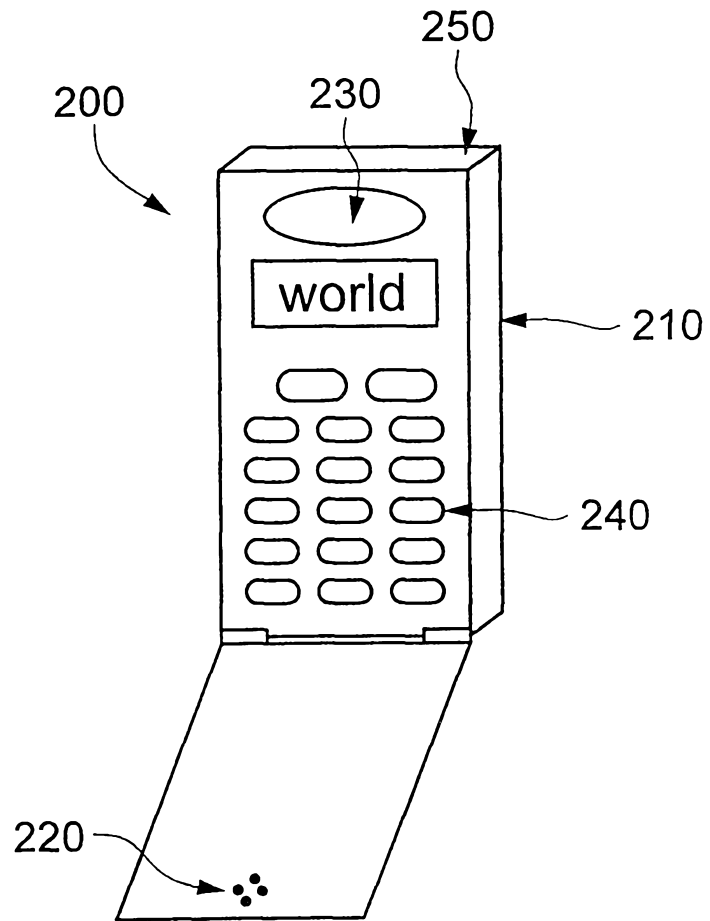

FIG. 2

3/7

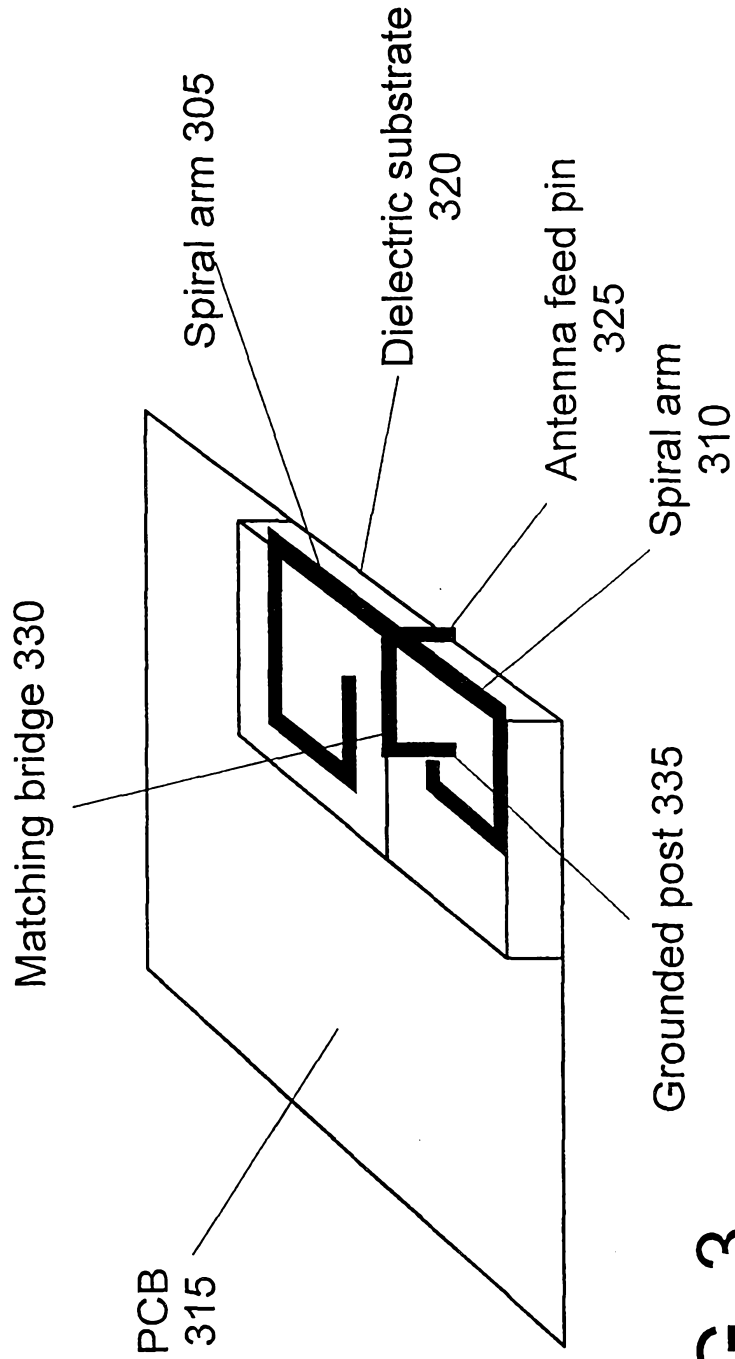

FIG. 3

4/7

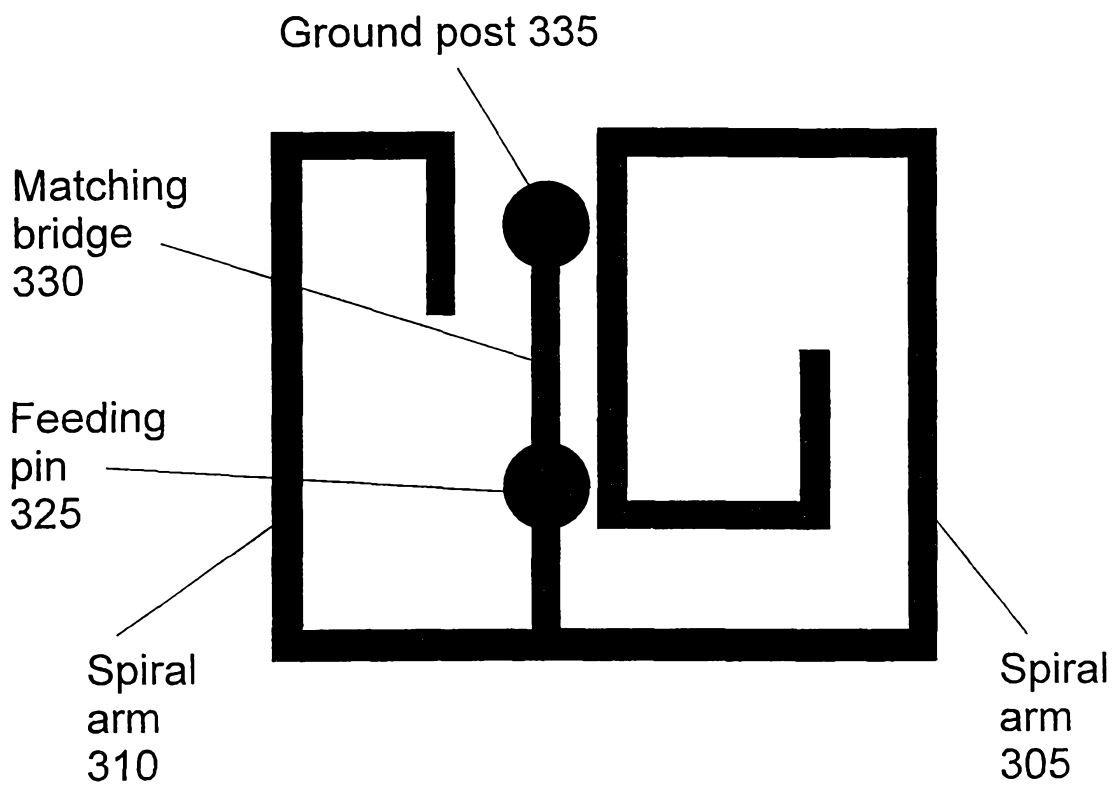

FIG. 4

5/7

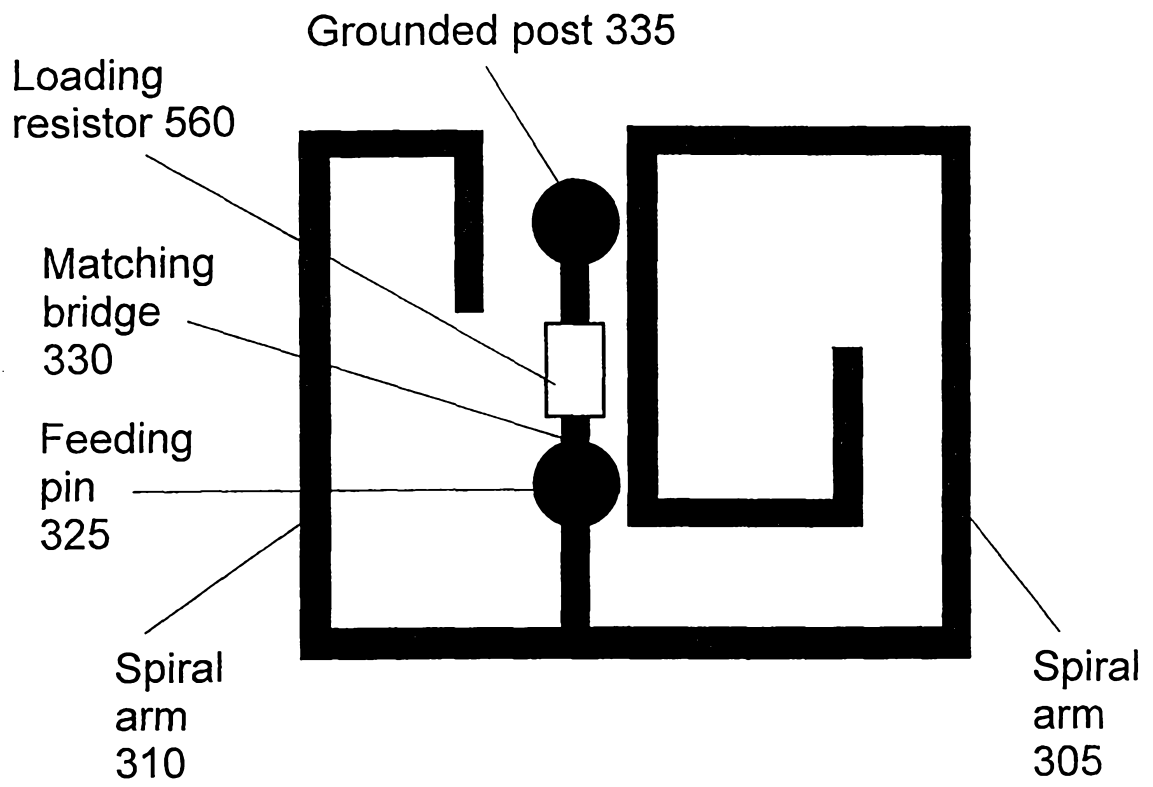

FIG. 5

6/7

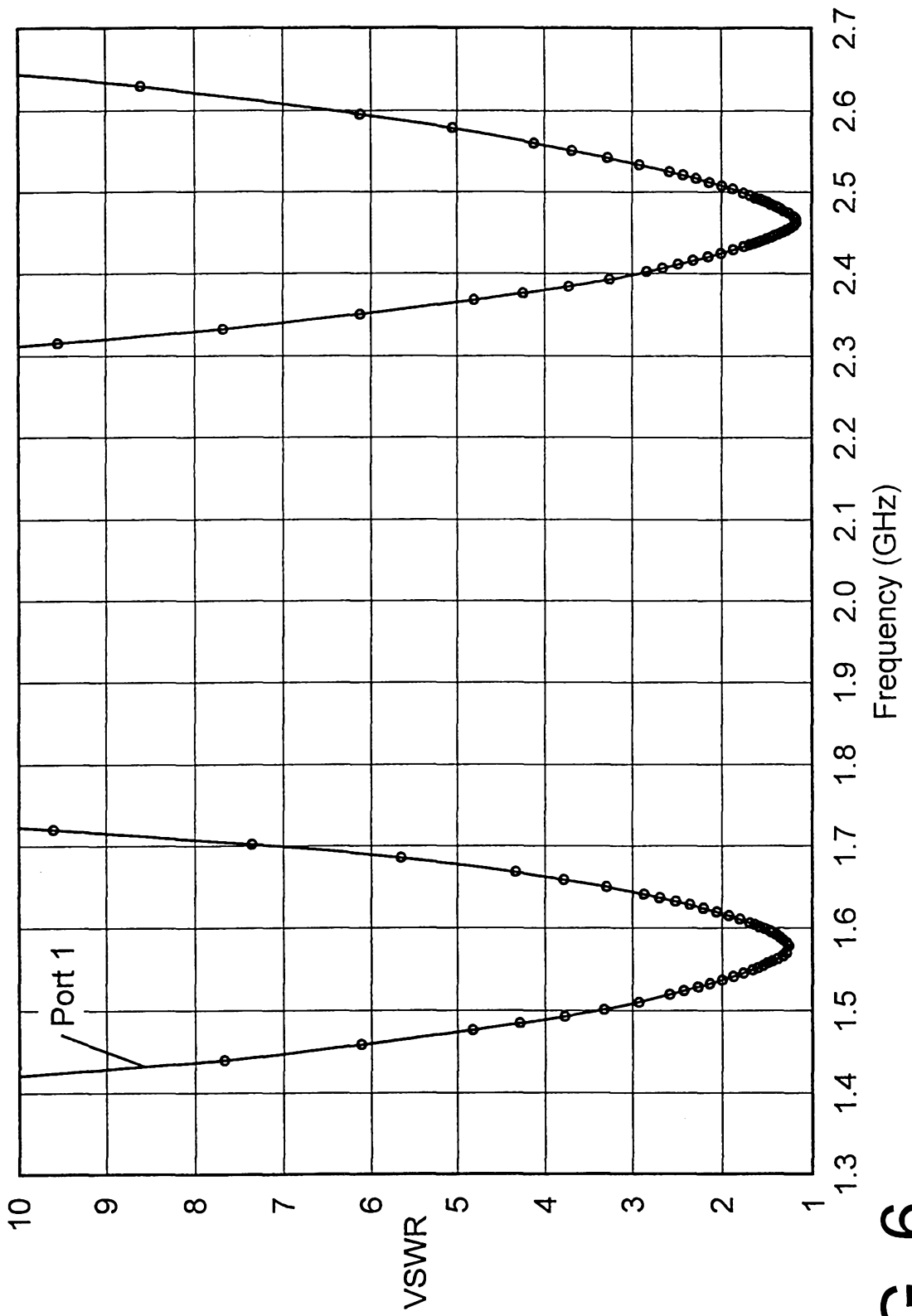

FIG. 6

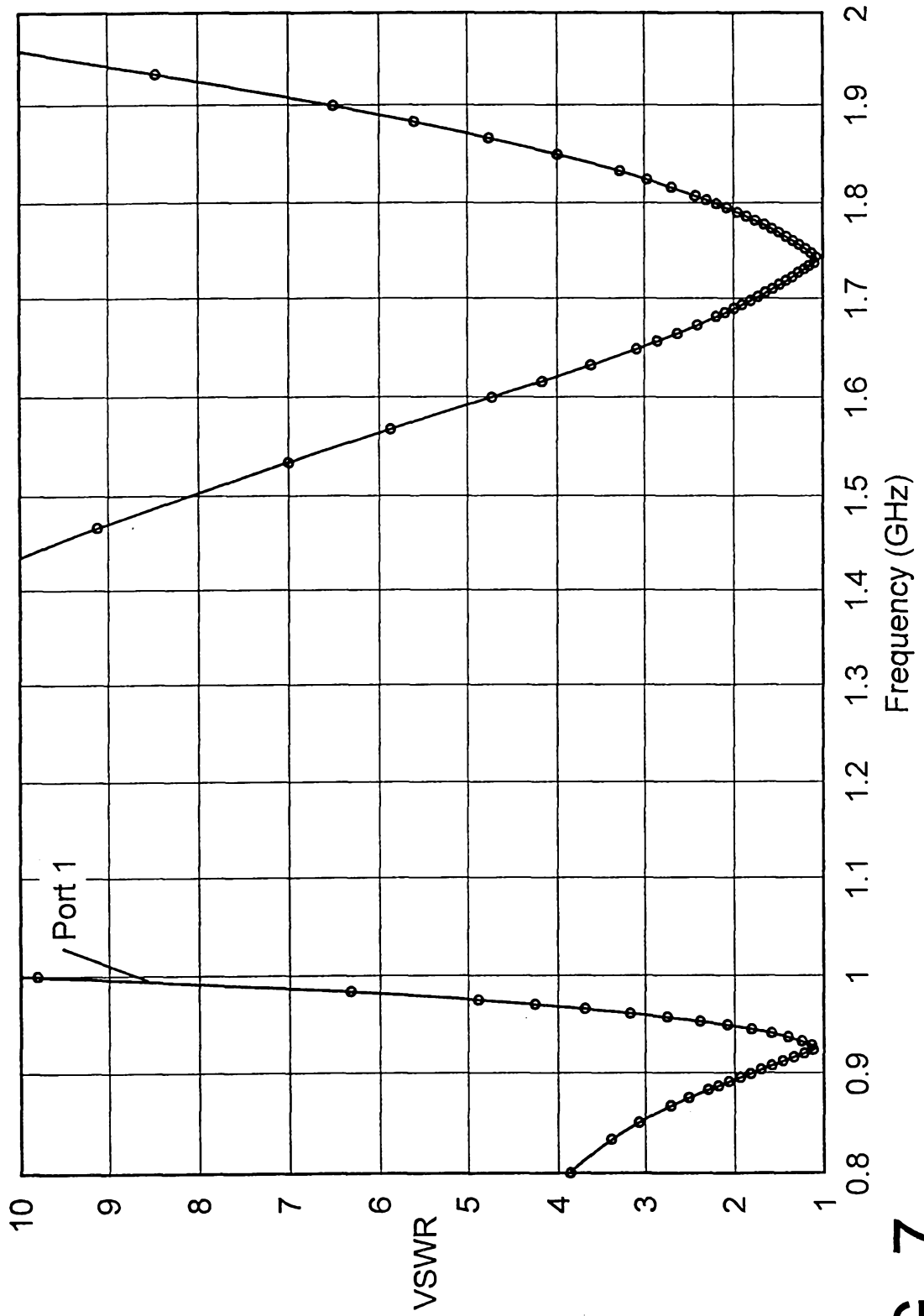

FIG. 7