

(19) World Intellectual Property Organization
International Bureau



(43) International Publication Date
4 February 2010 (04.02.2010)

PCT

(10) International Publication Number
WO 2010/014085 A1

(51) International Patent Classification:
H04B 10/00 (2006.01)

(21) International Application Number:
PCT/US2008/071564

(22) International Filing Date:
30 July 2008 (30.07.2008)

(25) Filing Language: English

(26) Publication Language: English

(71) Applicant (for all designated States except US): **MICRO MOTION, INC.** [US/US]; 7070 Winchester Circle, Boulder, Colorado 80301 (US).

(72) Inventors; and

(75) Inventors/Applicants (for US only): **LINDEMANN, Stig** [DK/DK]; Ivar Huitfeldts Gade 75, 4.sal, DK-8200 Aarhus N (DK). **NIELSEN, Mads Kolding** [DK/DK]; 21 Horsensvej, DK-8732 Hovedgaard (DK).

(74) Agents: **WILBERT, David, W.** et al.; The Ollila Law Group Llc, 2060 Broadway, Suite 300, Boulder, Colorado 80302 (US).

(81) Designated States (unless otherwise indicated, for every kind of national protection available): AE, AG, AL, AM, AO, AT, AU, AZ, BA, BB, BG, BH, BR, BW, BY, BZ,

CA, CH, CN, CO, CR, CU, CZ, DE, DK, DM, DO, DZ, EC, EE, EG, ES, FI, GB, GD, GE, GH, GM, GT, HN, HR, HU, ID, IL, IN, IS, JP, KE, KG, KM, KN, KP, KR, KZ, LA, LC, LK, LR, LS, LT, LU, LY, MA, MD, ME, MG, MK, MN, MW, MX, MY, MZ, NA, NG, NI, NO, NZ, OM, PG, PH, PL, PT, RO, RS, RU, SC, SD, SE, SG, SK, SL, SM, ST, SV, SY, TJ, TM, TN, TR, TT, TZ, UA, UG, US, UZ, VC, VN, ZA, ZM, ZW.

(84) Designated States (unless otherwise indicated, for every kind of regional protection available): ARIPO (BW, GH, GM, KE, LS, MW, MZ, NA, SD, SL, SZ, TZ, UG, ZM, ZW), Eurasian (AM, AZ, BY, KG, KZ, MD, RU, TJ, TM), European (AT, BE, BG, CH, CY, CZ, DE, DK, EE, ES, FI, FR, GB, GR, HR, HU, IE, IS, IT, LT, LU, LV, MC, MT, NL, NO, PL, PT, RO, SE, SI, SK, TR), OAPI (BF, BJ, CF, CG, CI, CM, GA, GN, GQ, GW, ML, MR, NE, SN, TD, TG).

Declarations under Rule 4.17:

— as to applicant's entitlement to apply for and be granted a patent (Rule 4.17(ii))

Published:

— with international search report (Art. 21(3))

WO 2010/014085 A1

(54) Title: METHOD AND APPARATUS FOR PULSE WIDTH MODULATION SIGNAL PROCESSING

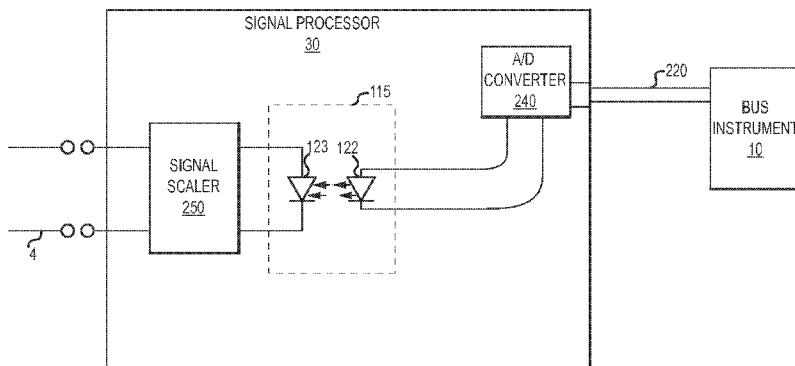

FIG. 2

(57) Abstract: A signal processor (30) is provided. The signal processor (30) is configured to receive a first analog signal and convert the first analog signal into a digital signal. The digital signal is transmitted across an electrical barrier and converted into a scaled pulse width modulation signal. The scaled pulse width modulation signal is then converted into a scaled second analog signal, which is output by the signal processor (30).

METHOD AND APPARATUS FOR PULSE WIDTH MODULATION SIGNAL PROCESSING

TECHNICAL FIELD

5 The present invention relates to a signal processor, and more particularly, to a signal processor with a scaled analog signal.

BACKGROUND OF THE INVENTION

10 Certain electrical circuits require data transmission between electrical instruments that are electrically isolated from one another. One example is when electrical instruments are coupled to a bus loop. Because bus loops provide communication between electrical instruments in addition to power, a problem can exist if the signal encoding schemes between the electrical instrument and the bus loop are not substantially the same. Electrical instruments utilizing bus loops, such as a two-wire
15 bus loop receive power and communicate through the bus loop using analog signals by controlling either the voltage or current draw. This first analog signal is then converted into a digital signal, processed, converted back into a second analog signal, and transmitted to another instrument or a host system. This method of communicating is adequate so long as the first and second signals are based on the same scale. Typically,
20 in a two-wire bus loop, the instrument varies the current between approximately 4-20mA, where 4mA corresponds to a minimum value and 20mA corresponds to a maximum value. A problem can arise however, if one of the electrical instruments is operating on a different current range, for example if the analog signal is limited to between approximately 12-20mA. Using this current range, 12mA would correspond to
25 a minimum value and 20mA would correspond to a maximum value. An error may occur if the analog signal received from the electrical instrument operating on a 12-20mA scale is sent to an electrical instrument operating on a 4-20mA scale.

 This error can be compounded in situations where the instruments are electrically isolated from one another. Although there are various configurations capable of such
30 data transmission, one common configuration utilizes optically coupled circuits. Typically, one instrument of the optically coupled circuit generates a first analog data signal, which is converted to a digital signal using an analog-to-digital converter. The

digital signal may comprise a serial bit stream value, which is transmitted using an optocoupler.

One problem with prior art optically coupled circuits is that they are limited in their ability to scale the first signal to accommodate instruments utilizing different signaling. In other words, the transmitted signal generally corresponds to the first analog signal encoding and not to the second analog signal encoding. This may be acceptable in limited situations; however, it may be desirable to scale the first signal to accommodate a different signal process. For example, if one of the instruments is optically coupled to a bus loop that operates on a scale different from the instrument itself, it may be necessary to scale the first signal to correspond to the second signal. The scaling may comprise any manner of linear or non-linear scaling to the signal such that the signal changes to accommodate the output analog signal encoding corresponding to another electrical instrument. Therefore, the prior art limits the first signals available to the instrument and therefore, limits the capabilities of the electrical instrument.

The present invention overcomes this and other problems and an advance in the art is achieved by performing runtime scaling of the bit-stream in order to provide an accurate second signal in situations where the first signaling does not substantially match the second signaling.

ASPECTS

According to an aspect of the invention, a signal processor is configured to:

receive a first analog signal;

convert the first analog signal into a digital signal;

transmit the digital signal across an electrical barrier;

generate a scaled pulse width modulation signal based on the digital signal; and

convert the scaled pulse width modulation signal into a second analog signal.

Preferably, the electrical barrier comprises an optocoupler.

Preferably, the signal processor is further configured to scale the pulse width modulation signal based on a difference between a first analog signal encoding utilized by a bus instrument coupled to an input of the signal processor and a second analog signal encoding utilized by a bus loop coupled to an output of the signal processor.

Preferably, the digital signal comprises a serial bit stream.

According to another aspect of the invention, a bus loop system including a bus instrument electrically isolated from a bus loop with a signal processor comprises:

an analog-to-digital converter adapted to convert a first analog signal received by

5 the bus instrument into a digital signal;

a signal transmitter adapted to transmit the digital signal to a signal scaler;

wherein the signal scaler is adapted to convert the digital signal into a scaled

pulse width modulation signal and convert the scaled pulse width

modulation signal into a scaled second analog signal.

10 Preferably, the signal transmitter comprises an optocoupler adapted to electrically isolate the bus instrument from the bus loop.

Preferably, a first analog signal encoding is different from a second analog signal encoding.

According to another aspect of the invention, a signal processor is configured to:

15 receive a first analog signal;

convert the first analog signal into a digital signal;

generate a pulse width modulation signal based on the digital signal;

transmit the pulse width modulation signal across an electrical barrier; and

convert the pulse width modulation signal into a scaled second analog signal.

20 Preferably, the signal processor is further configured to scale the digital signal based on a difference between a first analog signal encoding utilized by a bus instrument coupled to an input of the signal processor and a second analog signal encoding utilized by a bus loop coupled to an output of the signal processor.

According to another aspect of the invention, a method for transmitting signals

25 from an analog signal generator to an analog signal receiver, comprising the steps of:

generating a first analog signal;

converting the first analog signal into a digital signal;

transmitting the digital signal across an electrical barrier;

generating a scaled pulse width modulation signal based on the digital signal; and

30 converting the scaled pulse width modulation signal into a scaled second analog

signal.

Preferably, the method further comprises using an optocoupler to transmit the digital signal.

Preferably, the scaled second analog signal is based on a difference between a first analog signal encoding utilized by the analog signal generator and a second analog
5 signal encoding utilized by the analog signal receiver.

According to another aspect of the invention, a method for transmitting signals from an analog signal generator to an analog signal receiver, comprising the steps of:

receiving a first analog signal;

converting the first analog signal into a digital signal;

10 generating a pulse width modulation signal based on the digital signal;

transmitting the pulse width modulation signal across an electrical barrier; and

converting the pulse width modulation signal into a scaled second analog signal.

Preferably, the method further comprises using an optocoupler to transmit the digital signal.

15 Preferably, the scaled second analog signal is based on a difference between a first analog signal encoding utilized by the analog signal generator and a second analog signal encoding utilized by the analog signal receiver.

BRIEF DESCRIPTION OF THE DRAWINGS

20 FIG. 1 shows a bus loop system according to an embodiment of the invention.

FIG. 2 shows a signal processor according to an embodiment of the invention.

FIG. shows an algorithm performed by the signal scaler according to an embodiment of the invention.

25 FIG. 4 shows the signal processor according to another embodiment of the invention.

DETAILED DESCRIPTION OF THE INVENTION

FIGS. 1 – 4 and the following description depict specific examples to teach those skilled in the art how to make and use the best mode of the invention. For the purpose
30 of teaching inventive principles, some conventional aspects have been simplified or omitted. Those skilled in the art will appreciate variations from these examples that fall within the scope of the invention. Those skilled in the art will appreciate that the

features described below can be combined in various ways to form multiple variations of the invention. As a result, the invention is not limited to the specific examples described below, but only by the claims and their equivalents.

FIG. 1 shows a bus loop system 100 according to an embodiment of the invention. The bus loop 100 includes a host system 1, a bus loop 4, a bus instrument 10, and a signal processor 30 coupling the bus instrument 10 to the bus loop 4. The host system 1 generates a loop voltage V_L and a loop current I_L over the bus loop 4. The host system 1 may comprise a central control unit, a CPU, or some other processing system used to process the signals received over the bus loop 4. According to one embodiment of the invention, the bus loop 4 comprises a two-wire bus loop 4. However, it should be understood that the bus loop 4 does not have to comprise a two-wire bus loop.

The bus instrument 10 can include any manner of sensor or meter, such as a flow meter. In embodiments where the bus instrument 10 includes a flow meter, the flow meter may comprise a vibratory flow meter, such as a Coriolis flow meter or a densitometer. As shown in FIG. 1, the bus instrument 10 includes a sensor 13 and bus instrument electronics 20. The bus instrument electronics 20 may comprise any manner of CPU, processing system, or micro-processing system. According to an embodiment of the invention, the sensor 13 is configured to generate first analog signals and input the first analog signals to the bus instrument electronics 20. The bus instrument electronics 20 can generate second analog signals that are in the form of a variable loop current I_L flowing in the bus loop 4. The bus instrument 10 can be configured to draw a predetermined or limited amount of power when in use with the two-wire bus 4. Because of the measurement communication protocol and the power limitations built into the bus loop system 100, the bus instrument 10 may be isolated from the two-wire bus loop 4 using a signal processor 30. In some embodiments, the signal processor 30 can comprise an intrinsically safe (I.S.) barrier (dashed line).

The isolation limits the electrical power that the bus instrument 10 can draw from the two-wire bus loop 4 and the host system 1. The isolation prevents damage to the two-wire bus loop 4 and the host system 1 upon the event of catastrophic failure of the bus instrument 10. In addition, the isolation limits electrical power transfer through the I.S. barrier in order to eliminate an explosion hazard and prevent ignition of any explosive or flammable materials in the environment of the bus instrument 10.

FIG. 2 shows greater details of an isolation feature of the signal processor 30. The signal processor is shown as receiving a first analog signal from the bus instrument 10. However, it should be understood that the first analog signal does not have to originate from the bus instrument 10, but rather, the signal processor 30 may be utilized
5 in other environments where analog signal processing is required. The analog signal received from bus instrument 10 over leads 220 are received by an analog to digital converter 240 where the signals are digitized. According to one embodiment of the invention, the analog-to-digital converter 240 comprises a delta sigma converter, which converts the analog signal into a serial bit stream. However, it should be understood
10 that other analog-to-digital converters may be used and the particular analog-to-digital converter used should not limit the scope of the invention.

According to an embodiment of the invention, the signal processor 30 includes an optocoupler 115 that is connected between the two-wire bus loop 4 and the analog-to-digital converter 240. The optocoupler 115 may also be referred to as an opto-
15 isolator, optical coupler, or photocoupler. The optocoupler 115 electrically isolates the bus instrument 10 from the host system 1. Consequently, the bus instrument 10 cannot short out the two-wire bus loop 4. Furthermore, catastrophic failure of the bus instrument 10 cannot draw excessive current from the host system 1. The optocoupler 115 comprises a transmitter light source 122 and a receiver light source 123. The
20 transmitter and receiver light sources 122, 123 can comprise any manner of light-reactive electronic components, including laser transmitter and receiver light sources, LED transmitter and receiver light sources, LED laser transmitter and receiver light sources, etc.

The transmitter light source 122 and the receiver light source 123 are commonly
25 formed adjacent to each other wherein light generated by the transmitter light source 122 is directly received by the receiver light source 123. In other embodiments, the transmitter light source 122 and the receiver light source 123 are separated by some optical device, such as a fiber optic cable, for example. In some embodiments, the two components are formed into a single package as shown in FIG. 2. However, it should be
30 understood that in other embodiments the transmitter light source 122 and the receiver light source 123 may comprise separate components.

The transmitter light source 122 generates a light-encoded signal that comprises a conversion of electrical current into emitted light. The receiver light source 123 receives the light-encoded signal and converts the received light back into an electrical signal that is substantially identical to the original electrical signal at the transmitter
5 light source 122. The optocoupler 115 is therefore well suited for transferring digital signals.

In the embodiment shown in FIG. 2, the bus instrument 10 generates a first analog signal, which is sent to the analog-to-digital converter 240. The analog-to-digital converter 240 outputs a digital signal. The digital signal is received by the transmitter
10 light source 122 and sent to the receiver light source 123. The receiver light source 123 can then transmit the received signal to a signal scaler 250.

The signal scaler 250 can process the digital signals, which may be in the form of a serial bit stream, for example and convert the digital signal into a scaled pulse width modulation (PWM) signal. The PWM signal can then be converted into a second analog
15 signal and output to the bus loop 4. According to an embodiment of the invention, the signal scaler 250 is configured to scale the incoming bit stream from the receiver light source 123. The scaling may comprise any manner of linear or non-linear scaling. The scaling can occur before or during the conversion of the digital signal into the pulse width modulation signal. In other embodiments, the scaling can occur after the
20 conversion of the digital signal into a pulse width modulation signal. This can be helpful in situations where the signal processor is receiving first analog signals that are encoded different from the encoding used by the bus loop 4. For example, in a situation where the signal processor 30 is coupled to a bus instrument 10, such as a flow meter, that sends signals based on 12-20mA where 12mA represents zero flow and 20mA
25 represents maximum flow, but the bus loop 4 comprises a two-wire bus operating on a 4-20mA scale where 4mA represents zero flow and 20mA represents maximum flow. Without scaling the bit stream, the second analog signal would represent analog signals ranging from 12-20mA. The second analog signal would represent flow in the system when in fact there is zero flow. Therefore, without scaling the bit stream, an error may
30 be propagated throughout the system. It should be understood that the particular values used above are merely provided as an example and should not limit the scope of the invention as the particular values may vary depending on the specific implementation.

The signal scaler 250 according to an embodiment of the invention generates the pulse width modulation signal while simultaneously scaling the incoming bit stream. The signal scaler according to the present invention can scale the pulse width modulation signal based on a difference in the encoding of the signal used by the bus instrument 10 and the bus loop 4. Therefore, the scaling performed by the signal scaler 250 may comprise scaling of the pulse width modulation signal in order to accommodate the signal scale used by the host system 1. According to an embodiment of the invention, the signal scaler 250 can scale the pulse width modulation signal to accommodate a variety of bus instruments 10.

10 According to an embodiment of the invention, the signal scaler 250 generates a scaled PWM signal based on equations which represent a logical ‘0’ or a logical ‘1’ in the bit stream. Example equations are depicted as equation 1 and equation 2 below. It should be appreciated that equations 1 and 2 are merely examples and other equations could be utilized for generating the pulse width modulation signal without departing
15 from the scope of the invention.

$$A = \frac{R_2 * Dig_{Per}}{V_{ref-2}} * \left(\frac{I_{2-0\%}}{1000} * \frac{1-m_2}{m_1-m_2} - \frac{I_{2-100\%}}{1000} * \frac{1-m_1}{m_1-m_2} \right) \quad (1)$$

$$B = \frac{R_2 * Dig_{Per}}{V_{ref-2}} * \left(\frac{I_{2-100\%}}{1000} * \frac{m_1}{m_1-m_2} - \frac{I_{2-0\%}}{1000} * \frac{m_2}{m_1-m_2} \right) \quad (2)$$

where:

$$m_1 = \frac{I_{1-100\%}}{1000} * \frac{R_1 * Dig_{Per}}{V_{ref-1} * Dig_{FB}} - \frac{Dig_{off-1}}{Dig_{FB-1}} \quad (3)$$

20
$$m_2 = \frac{I_{1-100\%}}{1000} * \frac{R_1 * Dig_{Per}}{V_{ref-1} * Dig_{FB-1}} - \frac{Dig_{Off-1}}{Dig_{FB-1}} \quad (4)$$

and where the constants are:

R₁ = first impedance

R₂ = second impedance

V_{ref-1} = first reference voltage

25 V_{ref-2} = second reference voltage

Dig_{off-1} = first digital offset

Dig_{per} = periodic time

Dig_{FB-1} = feedback value

I_1 = first current

I_2 = second current

It should be appreciated that equations 1 and 2 can be adjusted by changing the constants used in the equations. The constants can be changed in order to scale the pulse width modulation signal to accommodate differences between the first and second analog signal. Specifically, the constants may be changed to accommodate changes between the signal encoding of the first current and the second current. The equations are based on the physical behavior of the system. In embodiments where the host system 1 is coupled to a two-wire bus 4 operating between approximately 4–20mA, a second current I_2 of approximately 4mA corresponds to 0% while a second current value of approximately 20mA corresponds to 100%. The first current values I_1 may be the same as the second, *i.e.*, 4mA–20mA, or may be a different scale, for example 12mA–20mA. Therefore, in embodiments where the first scale and the second scale are different, the constant values can be adjusted to compensate for the difference and therefore generate a scaled pulse width modulation signal corresponding to the analog signaling used by the bus loop 4.

In addition to adjusting the constants to accommodate for differences between the first and second signaling, the constants may also be adjusted to accommodate different bus instruments. Therefore, even if the bus instrument 10 and the host system 1 utilize the same signaling, the signal scaler 250 can scale the signal to adjust the signal for differences among the sensors 13. Thus, the same signal processor 30 may be used with multiple sensors in multiple environments simply by changing the constants input into equations 1 and 2. The constants may be in the form of a look up table, stored in an internal or external storage system of the signal processor 30, or manually input by a user/operator.

Once the signal scaler 250 generates the scaled pulse width modulation signal based on the bit stream, the scaled pulse width modulation signal is converted to a second analog signal that corresponds to the analog signaling used by the host system 1. It should be appreciated that the host system 1 is not required to perform any additional scaling of the signal. Rather any required scaling of the signal is already accomplished by the signal scaler 250.

FIG. 3 shows an algorithm 300 performed by the signal scaler 250 according to an embodiment of the invention. The algorithm starts in step 301 where the bit stream is received from the optocoupler 115. If the bit stream value equals 1, the algorithm moves to step 302 where the pulse width value is calculated by adding 'A' value from equation 1 to an accumulator (not shown) of the signal scaler 250. If on the other hand, the bit stream value equals 0, the algorithm moves to step 303 where the pulse width value is calculated by adding 'B' value from equation 2 to the accumulator. Thus, the accumulator generates the pulse width modulation signal based on the number of 'A' and 'B' values in the bit stream. The scaled PWM signal can then be output in step 404. Once the signal is sent, the algorithm returns to step 301. Based on the 'A' and 'B' values, the signal scaler 250 can generate a scaled pulse width modulation signal that corresponds to the second analog signal encoding rather than the first analog signal encoding. Thus, when the signal scaler 250 converts the pulse width modulation signal into the second analog signal, the correct value is represented in the second analog signal. Therefore, even if the bus instrument 10 is operating on a 12-20mA scale, the pulse width modulation signal generated corresponds to the 4-20mA scale used by the host system 1 and the bus loop 4. The scaling substantially prevents an error from occurring due to a difference in signaling between the bus instrument 10 and the host system 1.

FIG. 4 shows the signal processor 30 according to another embodiment of the invention. The signal processor 30 shown in FIG. 4 is configured to receive a first analog signal, convert the analog signal to a digital representation, generate a PWM signal based on the digital signal, transmit the PWM signal through the optocoupler, scale the PWM signal using a PWM decoder 442, and convert the scaled signal back into a second analog signal, wherein the first and second analog signal may or may not comprise the same value. In addition to the components shown in FIG. 2, the signal processor 30 of FIG. 5 also includes a pulse width generator 241 and a pulse width decoder 242. According to an embodiment of the invention, the pulse width generator 241 generates a PWM signal based on the serial bit stream received from the analog-to-digital converter 240. The PWM signal can then be transmitted via the optocoupler 115. According to an embodiment of the invention, the pulse width decoder 242 scales the PWM signal received from the receiver light source 123 into a signal useable by the bus

loop 4. The scaled PWM signal can then be converted into a second analog signal and output to the bus loop 4. This is in contrast to the signal processor shown in FIG. 2, which scales the signal while generating the PWM signal. Therefore, the signal processor 30 of FIG. 4 requires an additional step by requiring the pulse width decoder 5 242 to scale the PWM signal. It should be appreciated however, that overall, the signal processor 30 of FIG. 4 is still capable of scaling a signal prior to outputting it to the bus loop 4. Therefore, the bus instrument 10 and the host system 1 may still operate using different signaling or different scales.

According to another embodiment of the invention, the Pulse width generator 10 241 scales the PWM signal as described above prior to sending the signal to the optocoupler 115. Therefore, the pulse width decoder 242 only needs to convert the scaled PWM signal into a second analog signal prior to outputting the signal to the bus loop 4.

Although the above description has described the signal processor 30 as 15 comprising a component separate from the bus instrument 10, it should be understood that in some embodiments, the signal processor 30 comprises an integral component of the bus instrument 10. Therefore, according to an embodiment of the invention, the bus instrument electronics 20 can generate a scaled PWM signal and convert the scaled PWM signal into a second analog signal prior outputting a signal. Furthermore, 20 although the above description has discussed the signal processor 30 in combination with a bus instrument 10, it should be appreciated that the scaling that occurs within the signal processor 30 is equally applicable to any input analog signal. Furthermore, the signal processor 30 does not need to be connected to a bus loop 4. The discussion of the invention in relation to those components is merely for the purpose of aiding in the 25 understanding of the invention and should in no way limit the scope of the invention.

The claimed invention as described above provides a signal processing system 100 capable of transmitting a signal between two or more loop systems that may be operating under different encoding schemes. The signal processing system 100 is configured to scale the input digital signal into a signal that corresponds to the encoding 30 scheme of the second analog signal rather than the first analog signal. Thus, the delivered digital signal can be converted back into an analog signal without further processing.

The detailed descriptions of the above embodiments are not exhaustive descriptions of all embodiments contemplated by the inventors to be within the scope of the invention. Indeed, persons skilled in the art will recognize that certain elements of the above-described embodiments may variously be combined or eliminated to create
5 further embodiments, and such further embodiments fall within the scope and teachings of the invention. It will also be apparent to those of ordinary skill in the art that the above-described embodiments may be combined in whole or in part to create additional embodiments within the scope and teachings of the invention.

Thus, although specific embodiments of, and examples for, the invention are
10 described herein for illustrative purposes, various equivalent modifications are possible within the scope of the invention, as those skilled in the relevant art will recognize. The teachings provided herein can be applied to other bus loop electronics, and not just to the embodiments described above and shown in the accompanying figures. Accordingly, the scope of the invention should be determined from the following
15 claims.

CLAIMS

We claim:

1. A signal processor (30) configured to:
receive a first analog signal;
5 convert the first analog signal into a digital signal;
transmit the digital signal across an electrical barrier;
generate a scaled pulse width modulation signal based on the digital signal; and
convert the scaled pulse width modulation signal into a second analog signal.
- 10 2. The signal processor (30) of claim 1, wherein the electrical barrier comprises an
optocoupler (115).
3. The signal processor (30) of claim 1, further configured to scale the pulse width
modulation signal based on a difference between a first analog signal encoding utilized
15 by a bus instrument (10) coupled to an input of the signal processor (30) and a second
analog signal encoding utilized by a bus loop (4) coupled to an output of the signal
processor (30).
4. The signal processor (30) of claim 1, wherein the digital signal comprises a serial
20 bit stream.
5. A bus loop system (100) including a bus instrument (10) electrically isolated
from a bus loop (4) with a signal processor (30), comprising:
an analog-to-digital converter (240) adapted to convert a first analog signal
25 received by the bus instrument into a digital signal;
a signal transmitter (115) adapted to transmit the digital signal to a signal scaler
(250);
wherein the signal scaler (250) is adapted to convert the digital signal into a
scaled pulse width modulation signal and convert the scaled pulse width
30 modulation signal into a scaled second analog signal.

6. The bus loop system (100) of claim 5, wherein the signal transmitter (115) comprises an optocoupler adapted to electrically isolate the bus instrument (10) from the bus loop (4).
- 5 7. The bus loop system (100) of claim 5, wherein a first analog signal encoding is different from a second analog signal encoding.
8. A signal processor (30), configured to:
receive a first analog signal;
10 convert the first analog signal into a digital signal;
generate a pulse width modulation signal based on the digital signal;
transmit the pulse width modulation signal across an electrical barrier; and
convert the pulse width modulation signal into a scaled second analog signal.
- 15 9. The signal processor (30) of claim 8, further configured to scale the digital signal based on a difference between a first analog signal encoding utilized by a bus instrument (10) coupled to an input of the signal processor (30) and a second analog signal encoding utilized by a bus loop (4) coupled to an output of the signal processor (30).
- 20 10. A method for transmitting signals from an analog signal generator to an analog signal receiver, comprising the steps of:
generating a first analog signal;
converting the first analog signal into a digital signal;
transmitting the digital signal across an electrical barrier;
25 generating a scaled pulse width modulation signal based on the digital signal; and
converting the scaled pulse width modulation signal into a scaled second analog
signal.
11. The method of claim 10, further comprising using an optocoupler to transmit the
30 digital signal.

12. The method of claim 10, wherein the scaled second analog signal is based on a difference between a first analog signal encoding utilized by the analog signal generator and a second analog signal encoding utilized by the analog signal receiver.

5 13. A method for transmitting signals from an analog signal generator to an analog signal receiver, comprising the steps of:

receiving a first analog signal;

converting the first analog signal into a digital signal;

generating a pulse width modulation signal based on the digital signal;

10 transmitting the pulse width modulation signal across an electrical barrier; and

converting the pulse width modulation signal into a scaled second analog signal.

14. The method of claim 13, further comprising using an optocoupler to transmit the digital signal.

15

15. The method of claim 13, wherein the scaled second analog signal is based on a difference between a first analog signal encoding utilized by the analog signal generator and a second analog signal encoding utilized by the analog signal receiver.

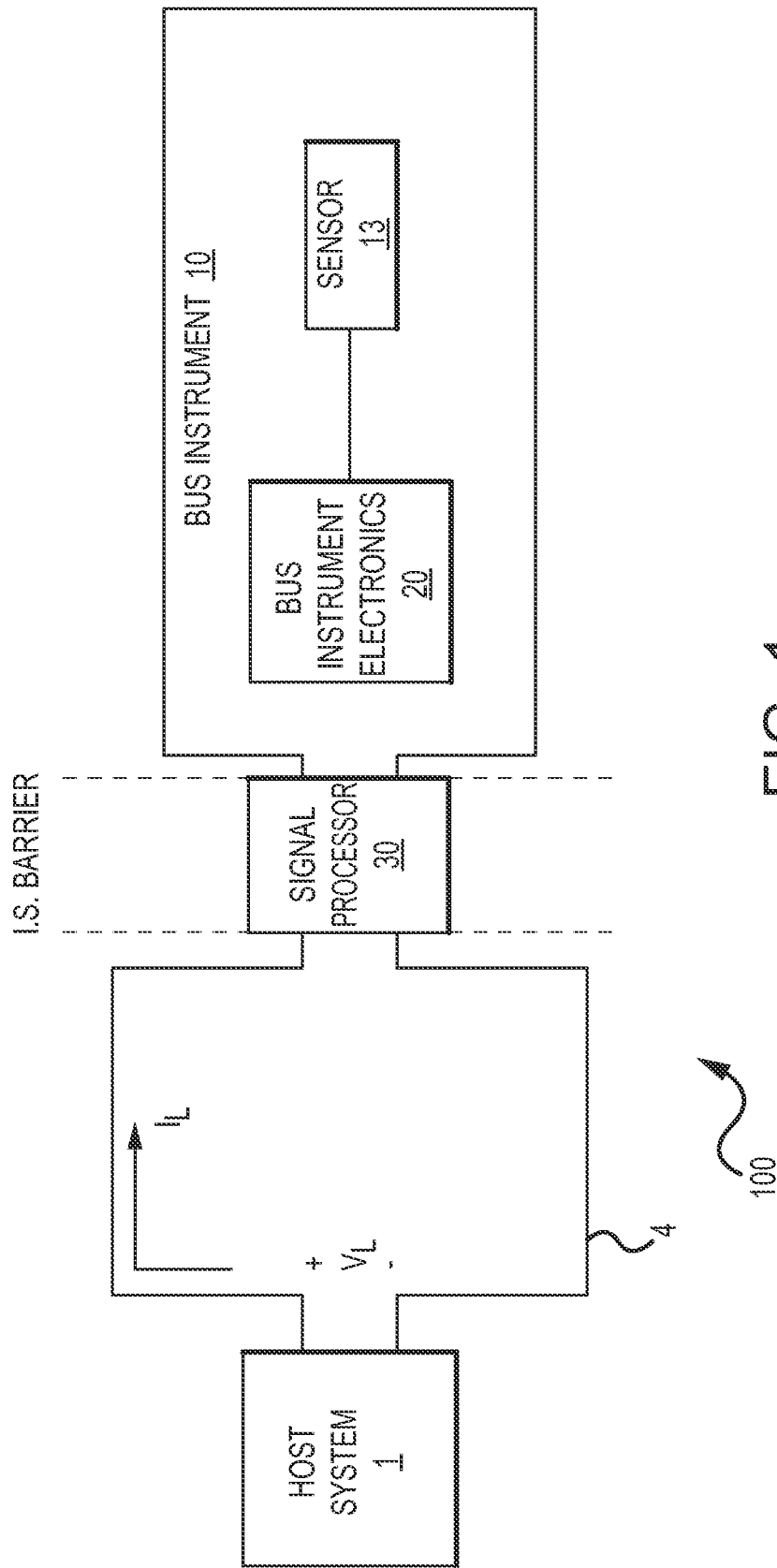

FIG. 1

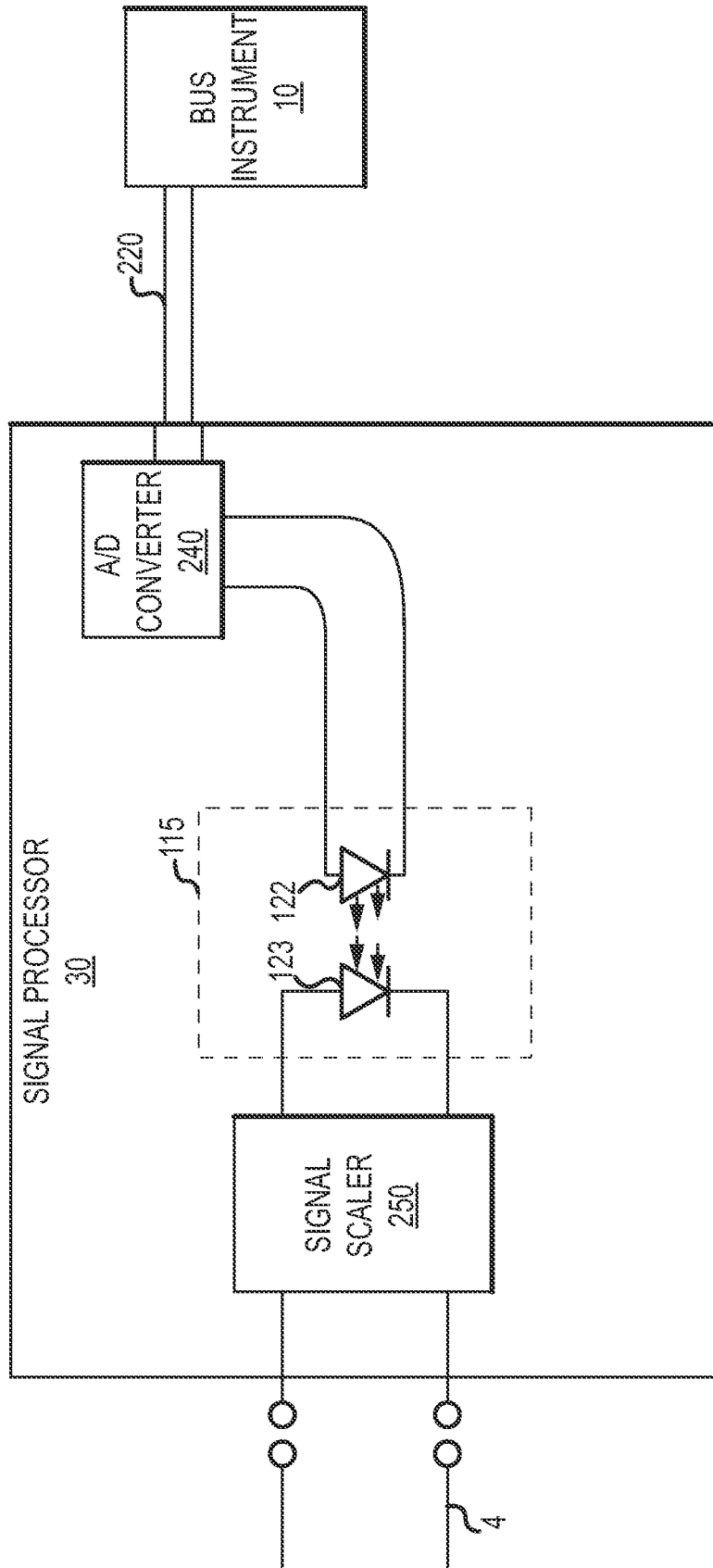

FIG. 2

3/4

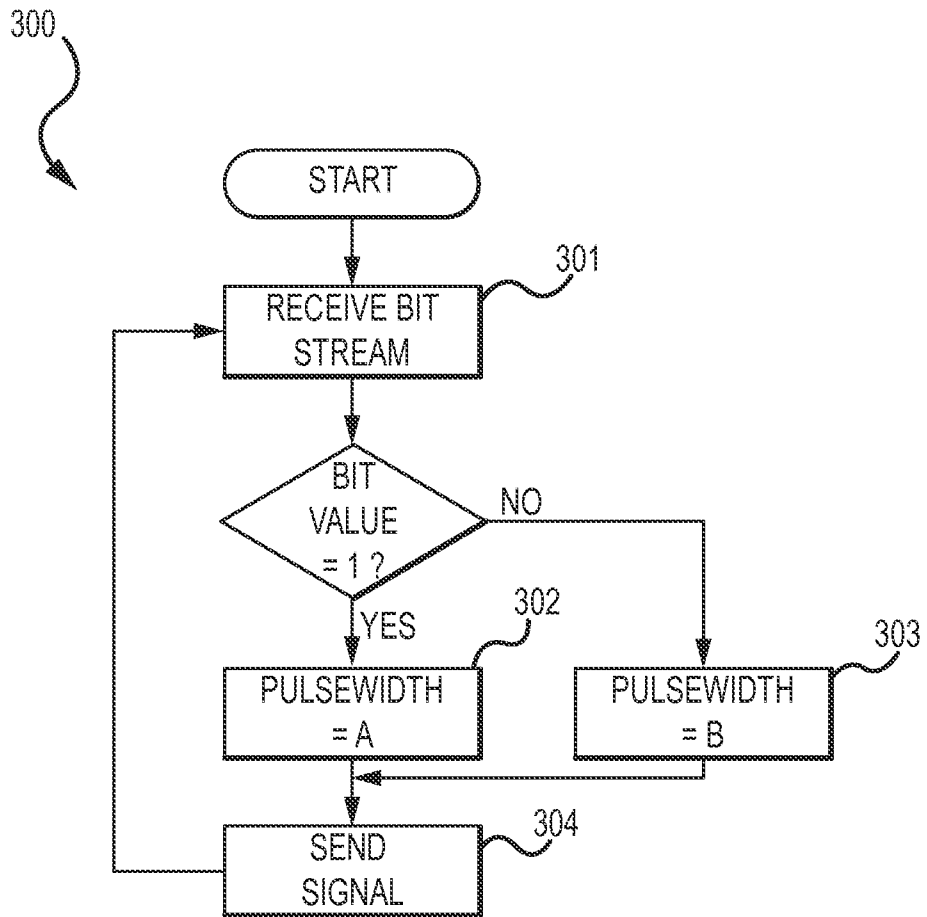

FIG. 3

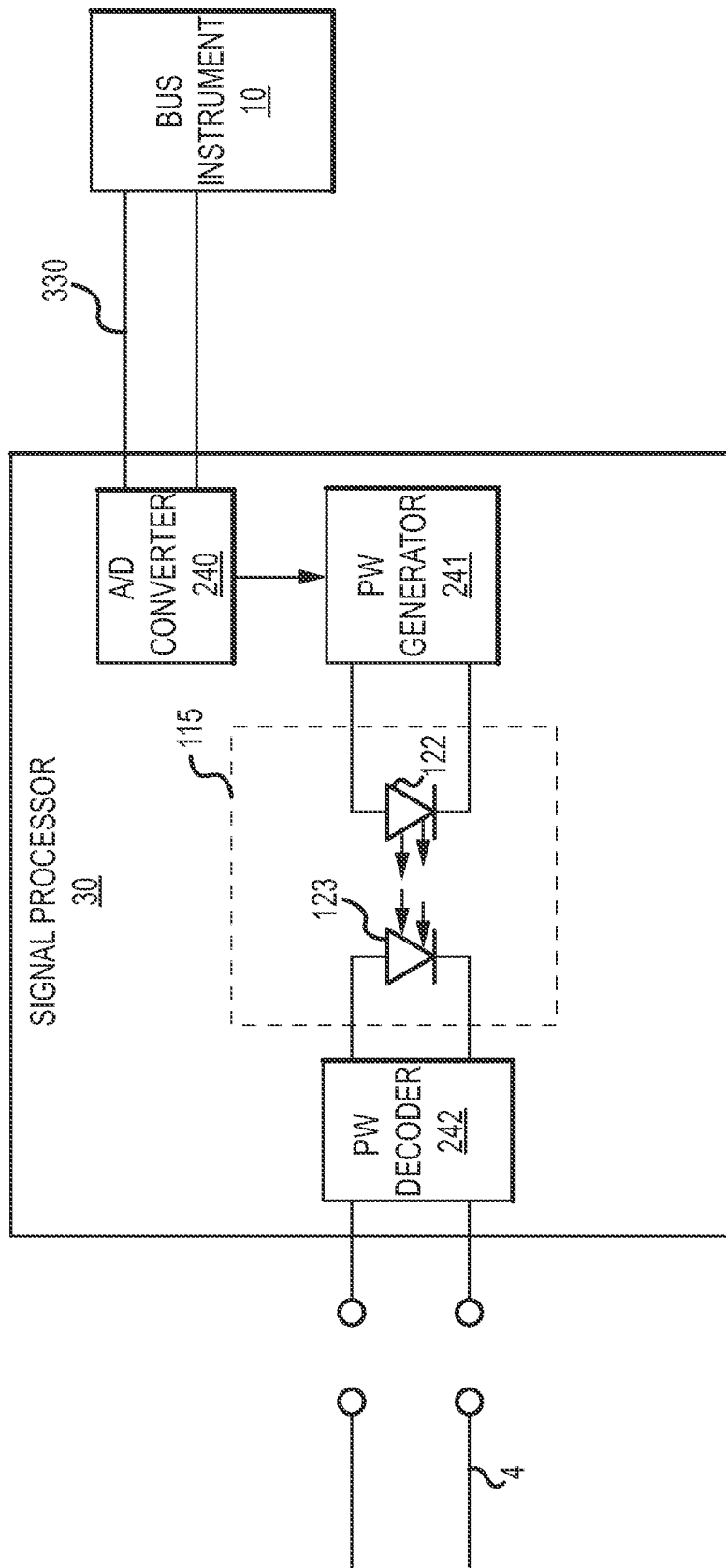

FIG. 4

INTERNATIONAL SEARCH REPORT

International application No

PCT/US2008/071564

A. CLASSIFICATION OF SUBJECT MATTER
INV. H04B10/00

According to International Patent Classification (IPC) or to both national classification and IPC

B. FIELDS SEARCHED

Minimum documentation searched (classification system followed by classification symbols)
H04B

Documentation searched other than minimum documentation to the extent that such documents are included in the fields searched

Electronic data base consulted during the international search (name of data base and, where practical, search terms used)

EPO-Internal, INSPEC

C. DOCUMENTS CONSIDERED TO BE RELEVANT

Category*	Citation of document, with indication, where appropriate, of the relevant passages	Relevant to claim No.
Y	US 5 434 694 A (SAITO HITOSHI [JP] ET AL) 18 July 1995 (1995-07-18) column 1, line 1 - column 1, line 13 column 5, line 24 - column 5, line 53; figure 10	1-15
Y	WO 98/33285 A (XIRCOM INC [US]) 30 July 1998 (1998-07-30) page 1, line 1 - page 1, line 2 page 1, line 21 - page 2, line 3 page 4, line 1 - page 4, line 28; figure 2	1-15
A	US 3 794 841 A (COSENTINO L ET AL) 26 February 1974 (1974-02-26) abstract; figure 1	1-15
	----- -/--	

Further documents are listed in the continuation of Box C.

See patent family annex.

* Special categories of cited documents :

A document defining the general state of the art which is not considered to be of particular relevance

E earlier document but published on or after the international filing date

L document which may throw doubts on priority claim(s) or which is cited to establish the publication date of another citation or other special reason (as specified)

O document referring to an oral disclosure, use, exhibition or other means

P document published prior to the international filing date but later than the priority date claimed

T later document published after the international filing date or priority date and not in conflict with the application but cited to understand the principle or theory underlying the invention

X document of particular relevance; the claimed invention cannot be considered novel or cannot be considered to involve an inventive step when the document is taken alone

Y document of particular relevance; the claimed invention cannot be considered to involve an inventive step when the document is combined with one or more other such documents, such combination being obvious to a person skilled in the art.

& document member of the same patent family

Date of the actual completion of the international search

25 March 2009

Date of mailing of the international search report

02/04/2009

Name and mailing address of the ISA/

European Patent Office, P.B. 5818 Patentlaan 2
NL - 2280 HV Rijswijk
Tel. (+31-70) 340-2040,
Fax: (+31-70) 340-3016

Authorized officer

Phillips, Simon

INTERNATIONAL SEARCH REPORT

International application No
PCT/US2008/071564

C(Continuation). DOCUMENTS CONSIDERED TO BE RELEVANT

Category*	Citation of document, with indication, where appropriate, of the relevant passages	Relevant to claim No.
A	US 5 949 225 A (SAWTELL CARL KEITH [US]) 7 September 1999 (1999-09-07) abstract; figure 1 -----	1-15
A	EP 0 863 624 A (ELSAG INT NV [NL] ELSAG INTERNAT N V [NL]) 9 September 1998 (1998-09-09) abstract; figure 1 -----	1-15

INTERNATIONAL SEARCH REPORT

Information on patent family members

International application No PCT/US2008/071564

Patent document cited in search report	A	Publication date	Patent family member(s)	Publication date
US 5434694	A	18-07-1995	NONE	
<hr/>				
WO 9833285	A	30-07-1998	AT 229713 T	15-12-2002
			AU 727568 B2	14-12-2000
			AU 6042398 A	18-08-1998
			CA 2276662 A1	30-07-1998
			DE 69810079 D1	23-01-2003
			EP 0956663 A1	17-11-1999
			JP 3413211 B2	03-06-2003
			JP 2000508152 T	27-06-2000
			US 5949085 A	07-09-1999
<hr/>				
US 3794841	A	26-02-1974	NONE	
<hr/>				
US 5949225	A	07-09-1999	NONE	
<hr/>				
EP 0863624	A	09-09-1998	BR 9800793 A	23-11-1999
			CA 2230749 A1	03-09-1998
			US 5995252 A	30-11-1999
<hr/>				