

No. 607,714.

Patented July 19, 1898.

A. STEPHENS.
ELECTRIC STOP MOTION FOR LOOMS.

(Application filed June 26, 1897.)

(No Model.)

Fig 1

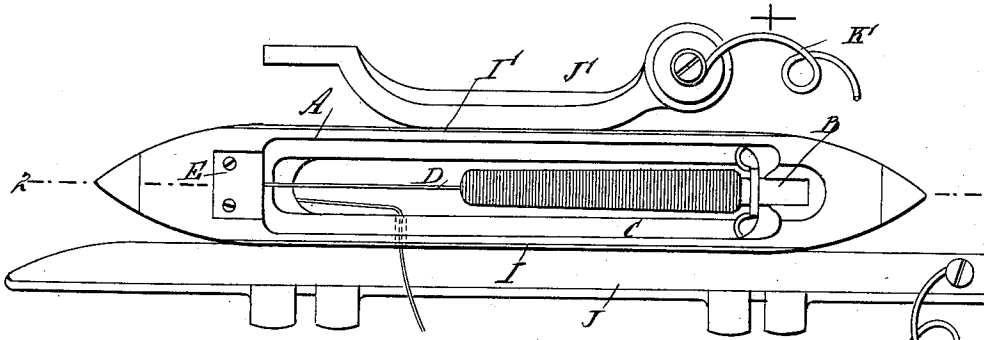

Fig 2

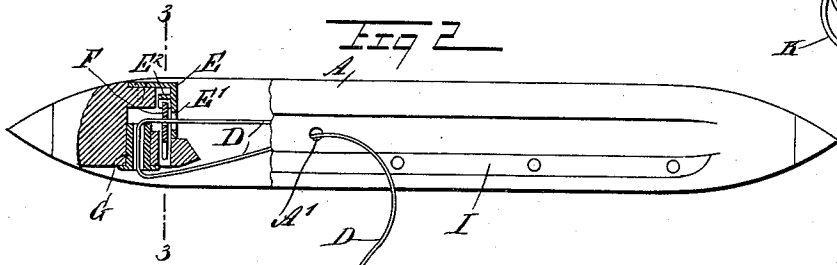

Fig 3

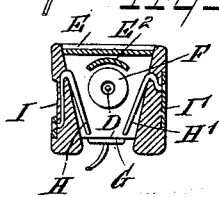
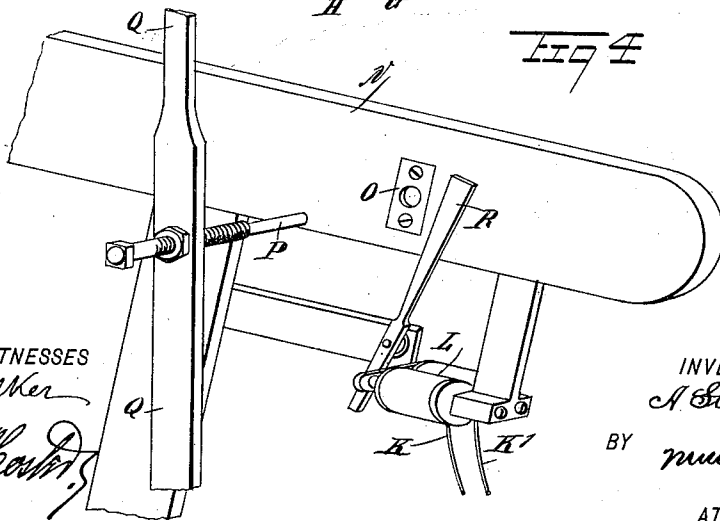

Fig 4



WITNESSES

N. Walker
Wm. G. ...

INVENTOR

A. Stephens.

BY

Murray

ATTORNEYS.

UNITED STATES PATENT OFFICE.

ALEJANDRO STEPHENS, OF GUADALAJARA, MEXICO.

ELECTRIC STOP-MOTION FOR LOOMS.

SPECIFICATION forming part of Letters Patent No. 607,714, dated July 19, 1898.

Application filed June 26, 1897. Serial No. 642,404. (No model.)

To all whom it may concern:

Be it known that I, ALEJANDRO STEPHENS, of Guadalajara, in the State of Jalisco and Republic of Mexico, have invented a new and Improved Electric Stop-Motion for Looms, of which the following is a full, clear, and exact description.

The object of the invention is to provide a new and improved electric stop-motion for looms whereby the loom is automatically stopped as soon as the filling in the shuttle is exhausted or the shuttle-thread breaks.

The invention consists of certain parts and details and combinations of the same, as will be fully described hereinafter and then pointed out in the claims.

Reference is to be had to the accompanying drawings, forming a part of this specification, in which similar characters of reference indicate corresponding parts in all the figures.

Figure 1 is a plan view of the improvement. Fig. 2 is a side elevation of the shuttle, with part in section, on the line 2 2 of Fig. 1. Fig. 3 is a transverse section of the same on the line 3 3 of Fig. 2, and Fig. 4 is a transverse view of the lay or batten and the mechanism for actuating the stop-lever.

The shuttle A of the loom is provided with the usual spindle B for carrying a bobbin C, containing the filling or shuttle thread D, adapted to pass from the bobbin C through an eye E' in a plate E, secured to one end of the shuttle A, as is plainly shown in the drawings. The thread after passing through the eye E' passes through a hole in a disk F to then pass through an eye G, secured in the under side of the shuttle, the thread then passing through a side opening A' to the outside of the shuttle in the usual manner. When the device is in use, the thread extends in an approximately straight line from the top of the eye G to the bobbin, so as to support the disk F in the rear of the plate E, the said disk being preferably made of copper and forming a circuit-closer normally held out of contact with contact-arms H H', secured in the sides of the shuttle and connected with conductors I I', secured to the sides of the shuttle, as is plainly shown in the drawings.

The recess in the shuttle in which the disk F is arranged extends out through the bot-

tom of the shuttle and is of a width a little greater than the thickness of the disk, so that the said disk will be guided in its fall when the thread breaks.

When it is desired to thread the shuttle, the latter is held in an upside-down position, so that the disk F rests on a segmental offset E², formed on the rear face of the plate E, to hold the opening of the said disk in register with the eye E' and permit of conveniently passing the thread D through the said eye and the hole in the said disk and through the eye G. When this has been done, the shuttle is turned over into its proper position and placed in the raceway of the loom.

The conductors I I' make contact with contact-plates J J', respectively held on the end of the raceway and connected by wires K K' with a battery or other suitable source of electricity-supply. The said wires also connect with electromagnets L, carried on a lay N, formed with an apertured plate O, adapted to engage a pin P, secured or otherwise adjustably held in the stop-lever Q for the loom. The apertured plate O is adapted to be closed to prevent the entrance of the pin P by a plate R, forming the armature for the electromagnets L, so that when the latter are energized and the armature-lever is attracted then the upper end thereof closes the plate O, so that upon the return movement of the lay N the plate R engages the end of the pin P and imparts a swinging motion to the stop-lever Q to cause a stopping of the loom.

Now it will be seen that when the device is in use and the shuttle operates in the usual manner then the disk F is held out of contact with the arms H H' by the shuttle-thread D. The circuit containing the electromagnets thus remains broken as long as the said disk F is in a suspended position; but whenever the thread runs out or breaks and the disk F drops by its gravity to make contact with the arms H H' then the electric circuit is closed as soon as the shuttle passes between the contact-plates J J'. When this takes place, the electromagnets L are energized, and consequently attract the armature-lever R to close the plate O, so that the lay N imparts a swinging motion to the stop-lever Q to throw the latter off to stop the loom in the usual manner.

Having thus fully described my invention, I claim as new and desire to secure by Letters Patent—

1. The combination with a shuttle provided at one end with two eyes at right angles to each other, and a guide-recess between them, of a loose disk arranged in said recess and guided thereby, and provided with an aperture through which the shuttle-thread is adapted to be passed to support and hold the disk, and contact arms or plates in the shuttle and with which the said disk contacts when the thread breaks, substantially as described.

2. The combination with the lay, and a stop-lever provided with a projection, of an electric circuit containing an electromagnet, a swinging armature-lever carried by the lay and adapted to be moved into the path of the projection on the stop-lever when the electromagnet is energized, a shuttle provided with two eyes at right angles to each other and a guide-recess between the eyes, contact-plates in the shuttle, and a loose disk in the said recess of the shuttle and provided with an aperture to receive the thread by which it is supported out of contact with the contact-plates, substantially as described.

3. The combination with the lay having an aperture therein, and a stop-lever provided with a pin adapted to enter the aperture of the lay, of an electric circuit containing an electromagnet, a swinging armature-lever carried by the lay and adapted to be swung by the electromagnet over the aperture in the lay to prevent the pin of the stop-lever from entering the said aperture, a shuttle provided with two eyes at right angles

to each other, and a recess between the eyes, contact-plates in the shuttle, and a loose disk in the said recess and provided with an aperture to receive the thread by which it is supported out of contact with the said plates, substantially as described.

4. In an electric stop-motion for looms, the combination with a shuttle and contact-plates therein, of an eyeplate in the shuttle and having a segmental offset on its rear face, and a loose disk forming a circuit-breaker, and provided with a central aperture through which the shuttle-thread passes to support said disk, substantially as described.

5. The combination with the lay having an aperture, a stop-lever provided with a pin, contact-plates on the shuttle-race connected with a source of electric supply, and an electric magnet in the circuit, of a swinging armature-lever for the electromagnet, said lever being adapted to be swung over the aperture of the lay to prevent the pin of the stop-lever from entering the same, a shuttle provided with two eyes at right angles to each other and a recess between the eyes, contact-arms in the shuttle, conductors on the outside of the shuttle and connected with said contact-arms, said conductors being adapted to make contact with the plates on the shuttle-race, and a loose apertured disk supported in the recess in the shuttle by the shuttle-thread out of contact with the said arms, substantially as described.

ALEJANDRO STEPHENS.

Witnesses:

V. HUBER,
LUIS MORANDINI.