



US00D754347S

(12) **United States Design Patent**
Amato et al.

(10) **Patent No.:** **US D754,347 S**
(45) **Date of Patent:** **** Apr. 19, 2016**

(54) **GROWTH CONTROL DEVICE**

(71) Applicant: **BIOMET MANUFACTURING, LLC**,
Warsaw, IN (US)

(72) Inventors: **Matthew F. Amato**, Lawrenceville, NJ
(US); **Stephen B. Walulik**, Fort Wayne,
IN (US)

(73) Assignee: **BIOMET MANUFACTURING, LLC**,
Warsaw, IN (US)

(**) Term: **14 Years**

(21) Appl. No.: **29/492,689**

(22) Filed: **Jun. 2, 2014**

Related U.S. Application Data

(63) Continuation of application No. 13/483,231, filed on
May 30, 2012, now Pat. No. 8,801,760, which is a
continuation of application No. 12/166,833, filed on
Jul. 2, 2008, now Pat. No. 8,273,111.

(51) **LOC (10) Cl.** **24-02**

(52) **U.S. Cl.**
USPC **D24/155**

(58) **Field of Classification Search**
USPC D24/155
CPC A61B 17/8061; A61B 17/7059; A61B
17/8052; A61B 17/8605; A61B 17/8085;
A61B 17/809; A61B 17/8014; A61B 17/8033;
A61B 17/8004; A61B 17/888; A61B 17/842;
A61B 17/8023; A61B 17/8009; A61B 17/86;
A61B 17/1739; A61B 17/8066; A61B
17/1671; A61B 17/1757; A61B 17/8071;
A61B 17/176; A61B 2017/1782; A61B
2017/1775

See application file for complete search history.

(56) **References Cited**

U.S. PATENT DOCUMENTS

D480,141 S * 9/2003 Benirschke D24/155
D520,637 S * 5/2006 Kay D24/155
D630,750 S * 1/2011 Graham D24/155
D648,027 S * 11/2011 Vancelette D24/155
8,118,846 B2 * 2/2012 Leither A61B 17/8057
606/280
D699,351 S * 2/2014 Podgorski D24/155

* cited by examiner

Primary Examiner — Susan Hattan

Assistant Examiner — Charles Hanson

(74) *Attorney, Agent, or Firm* — Schwegman Lundberg &
Woessner, P.A.

(57) **CLAIM**

The ornamental design for a growth control device, as shown
and described.

DESCRIPTION

FIG. 1 is a front perspective view of a growth control device
in accordance with a first embodiment of the present inven-
tion;

FIG. 2 is a top plan view of the growth control device shown
in FIG. 1;

FIG. 3 is a right side elevation view of the growth control
device as oriented in FIG. 2, the left side elevational view
being a mirror image thereof;

FIG. 4 is a bottom plan view of the growth control device
shown in FIG. 1;

FIG. 5 is a right side elevation view of the growth control
device as oriented in FIG. 4, the left side elevational view
being a mirror image thereof;

FIG. 6 is a front end elevation view of the growth control
device shown in FIG. 1; and,

FIG. 7 is a rear end elevation view of the growth control
device shown in FIG. 1.

It will be understood that the broken lines shown in FIGS. 1-7
illustrate structure associated with the present invention but
form no part of the claimed design.

1 Claim, 4 Drawing Sheets

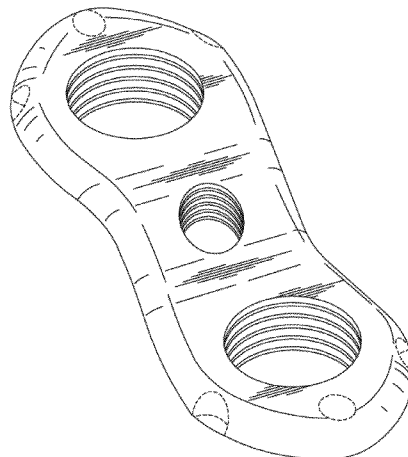

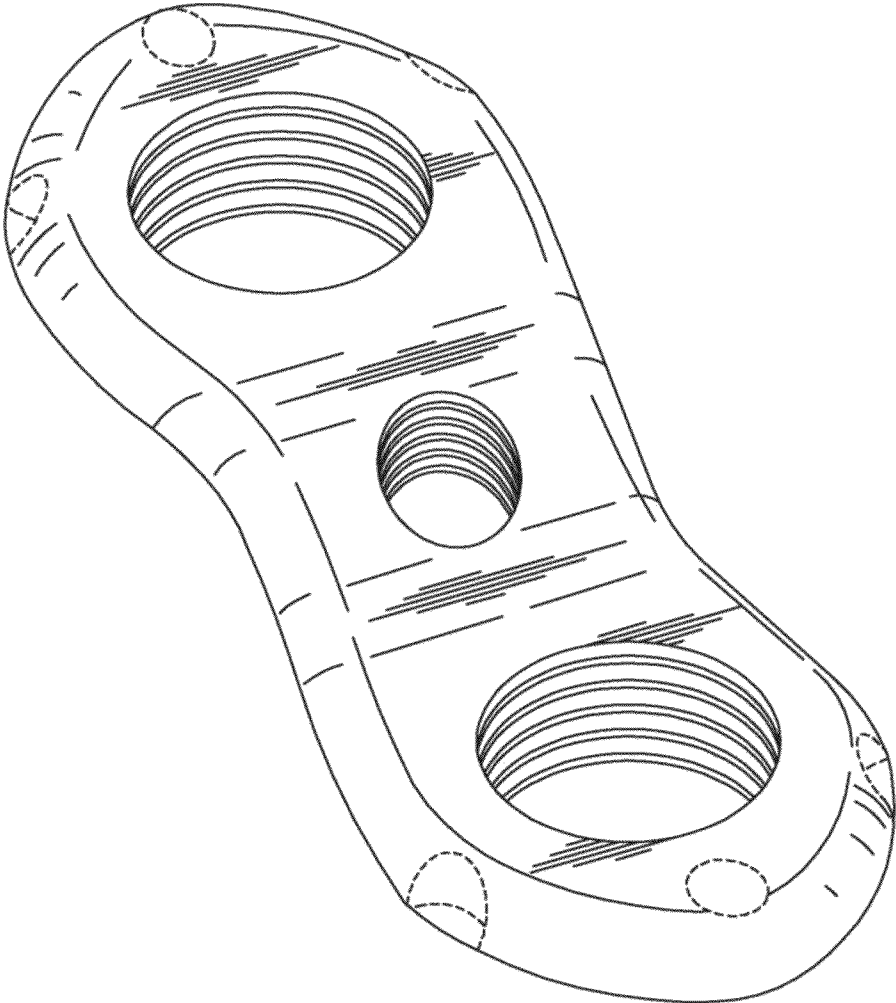

FIG 1

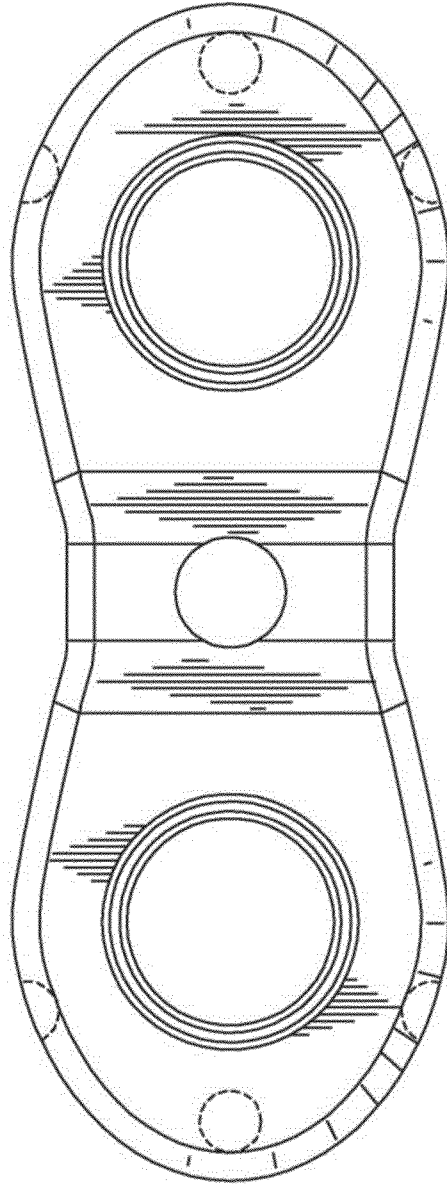

FIG 2

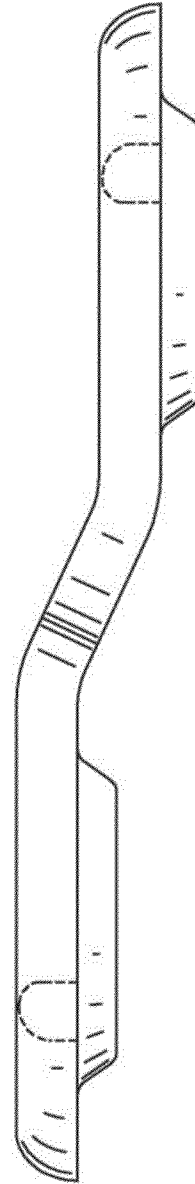

FIG 3

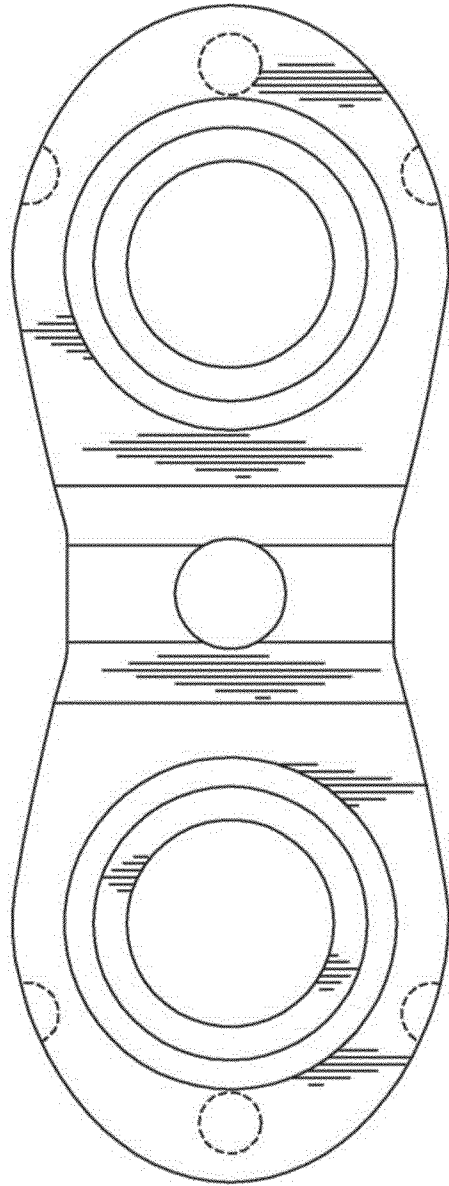

FIG 4

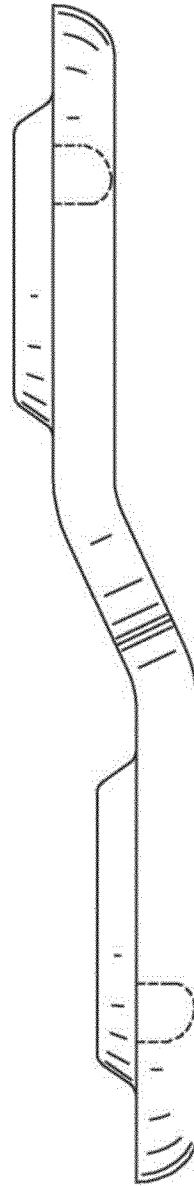

FIG 5

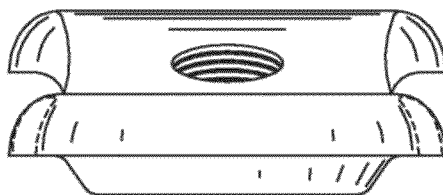

FIG 6

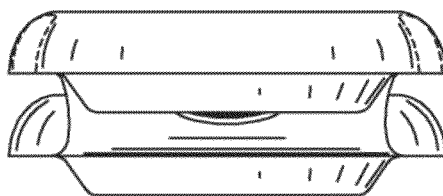

FIG 7