

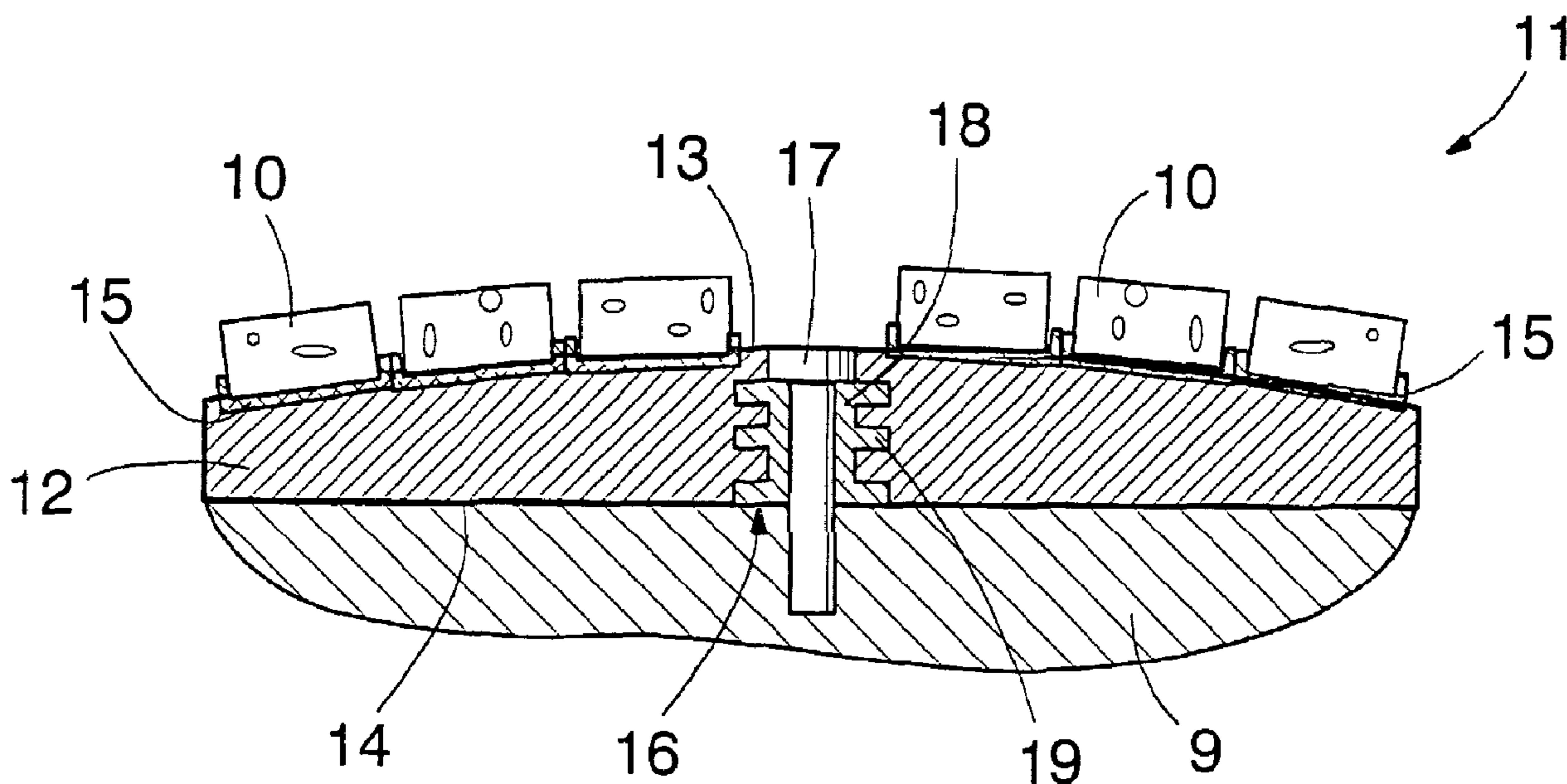

(86) Date de dépôt PCT/PCT Filing Date: 2002/03/15
 (87) Date publication PCT/PCT Publication Date: 2002/09/26
 (45) Date de délivrance/Issue Date: 2009/08/25
 (85) Entrée phase nationale/National Entry: 2003/09/10
 (86) N° demande PCT/PCT Application No.: FI 2002/000218
 (87) N° publication PCT/PCT Publication No.: 2002/075041
 (30) Priorité/Priority: 2001/03/16 (FI20010535)

(51) Cl.Int./Int.Cl. *D21B 1/28* (2006.01)
 (72) Inventeur/Inventor:
 TUOVINEN, OLLI, FI
 (73) Propriétaire/Owner:
 METSO PAPER INC., FI
 (74) Agent: RIDOUT & MAYBEE LLP

(54) Titre : ELEMENT DE MEULAGE ET MEULE
 (54) Title: GRINDING ELEMENT AND GRINDER STONE



(57) Abrégé/Abstract:

The invention relates to a grinding element, which comprises a substantially planar fastening frame (12), and where two or more grinding segments (10) made of grinding ceramic material are fastened to the outer surface of the frame by means of bonding agent (15). The fastening frame (12) preferably comprises at least one fastening hole (16), and a fastening bolt (17) is supplied through the hole to fasten the grinding element (11) to the frame (9) of the grinder stone. The invention further relates to a grinder stone, where a grinding surface is formed by arranging a required number of grinding elements according to the invention on the outer circumference of the stone's frame.

(12) INTERNATIONAL APPLICATION PUBLISHED UNDER THE PATENT COOPERATION TREATY (PCT)

(19) World Intellectual Property Organization
International Bureau(43) International Publication Date
26 September 2002 (26.09.2002)

PCT

(10) International Publication Number
WO 02/075041 A1(51) International Patent Classification⁷: D21B 1/28

(21) International Application Number: PCT/FI02/00218

(22) International Filing Date: 15 March 2002 (15.03.2002)

(25) Filing Language: English

(26) Publication Language: English

(30) Priority Data:
20010535 16 March 2001 (16.03.2001) FI(71) Applicant (for all designated States except US): METSO
PAPER INC. [FI/FI]; Fabianinkatu 9 A, FIN-00130
Helsinki (FI).

(72) Inventor; and

(75) Inventor/Applicant (for US only): TUOVINEN, Olli
[FI/FI]; Jousikatu 6, FIN-33530 Tampere (FI).(74) Agent: KOLSTER OY AB; Iso Roobertinkatu 23,
P.O.Box 148, FIN-00121 Helsinki (FI).(81) Designated States (national): AE, AG, AL, AM, AT, AT
(utility model), AU, AZ, BA, BB, BG, BR, BY, BZ, CA,CH, CN, CO, CR, CU, CZ, CZ (utility model), DE, DE
(utility model), DK, DK (utility model), DM, DZ, EC, EE,
EE (utility model), ES, FI, FI (utility model), GB, GD, GE,
GH, GM, HR, HU, ID, IL, IN, IS, JP, KE, KG, KP, KR,
KZ, LC, LK, LR, LS, LT, LU, LV, MA, MD, MG, MK,
MN, MW, MX, MZ, NO, NZ, OM, PH, PL, PT, RO, RU,
SD, SE, SG, SI, SK, SK (utility model), SL, TJ, TM, TN,
TR, TT, TZ, UA, UG, US, UZ, VN, YU, ZA, ZM, ZW.(84) Designated States (regional): ARIPO patent (GH, GM,
KE, LS, MW, MZ, SD, SL, SZ, TZ, UG, ZM, ZW),
Eurasian patent (AM, AZ, BY, KG, KZ, MD, RU, TJ, TM),
European patent (AT, BE, CH, CY, DE, DK, ES, FI, FR,
GB, GR, IE, IT, LU, MC, NL, PT, SE, TR), OAPI patent
(BF, BJ, CF, CG, CI, CM, GA, GN, GQ, GW, ML, MR,
NE, SN, TD, TG).

Declarations under Rule 4.17:

— as to applicant's entitlement to apply for and be granted
a patent (Rule 4.17(ii)) for the following designations AE,
AG, AL, AM, AT, AU, AZ, BA, BB, BG, BR, BY, BZ, CA,
CH, CN, CO, CR, CU, CZ, DE, DK, DM, DZ, EC, EE, ES,
FI, GB, GD, GE, GH, GM, HR, HU, ID, IL, IN, IS, JP, KE,
KG, KP, KR, KZ, LC, LK, LR, LS, LT, LU, LV, MA, MD, MG,

[Continued on next page]

(54) Title: GRINDING ELEMENT AND GRINDER STONE

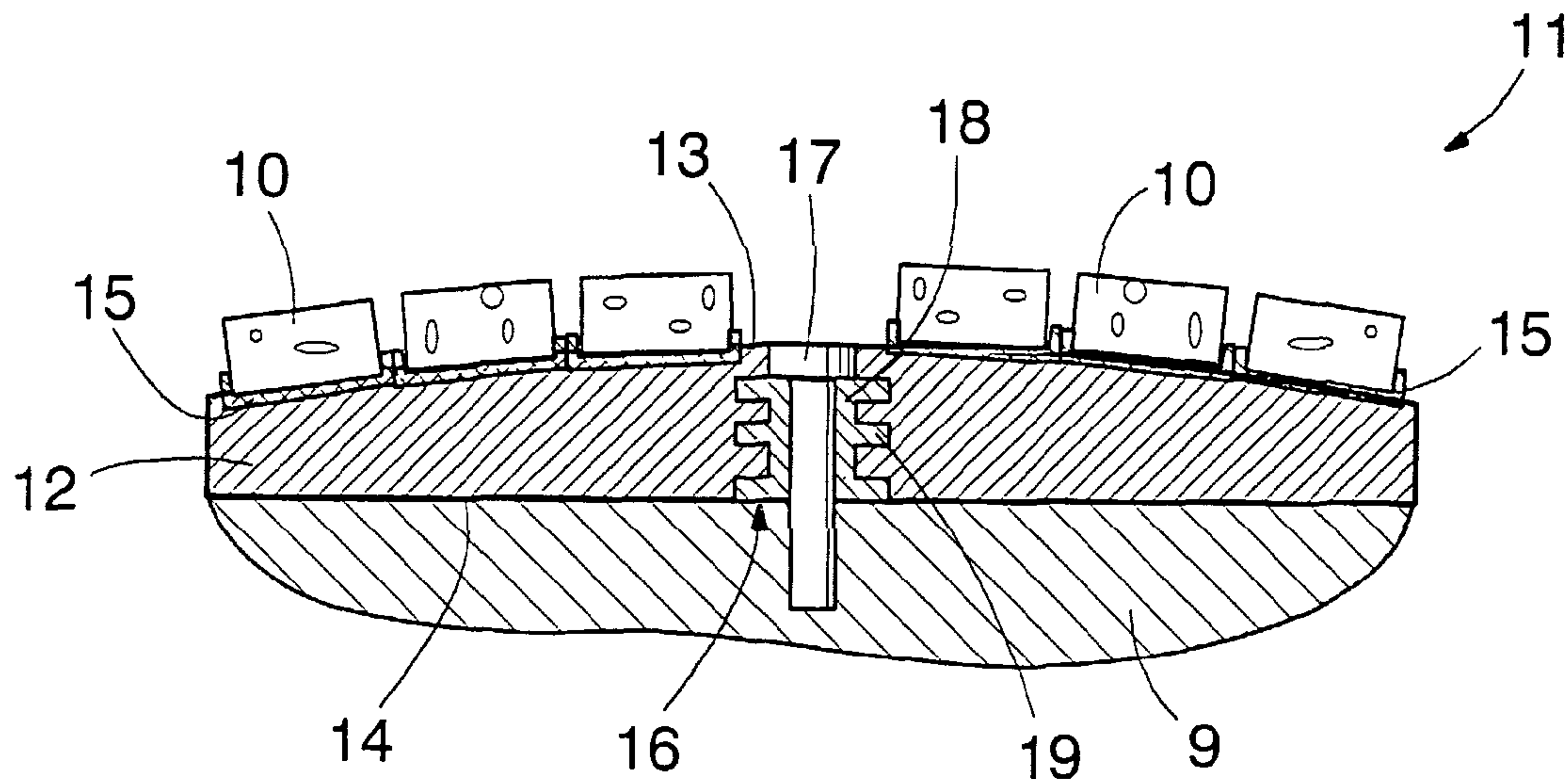

(57) Abstract: The invention relates to a grinding element, which comprises a substantially planar fastening frame (12), and where two or more grinding segments (10) made of grinding ceramic material are fastened to the outer surface of the frame by means of bonding agent (15). The fastening frame (12) preferably comprises at least one fastening hole (16), and a fastening bolt (17) is supplied through the hole to fasten the grinding element (11) to the frame (9) of the grinder stone. The invention further relates to a grinder stone, where a grinding surface is formed by arranging a required number of grinding elements according to the invention on the outer circumference of the stone's frame.



WO 02/075041 A1



MK, MN, MW, MX, MZ, NO, NZ, OM, PH, PL, PT, RO, RU, SD, SE, SG, SI, SK, SL, TJ, TM, TN, TR, TT, TZ, UA, UG, UZ, VN, YU, ZA, ZM, ZW, ARIPO patent (GH, GM, KE, LS, MW, MZ, SD, SL, SZ, TZ, UG, ZM, ZW), Eurasian patent (AM, AZ, BY, KG, KZ, MD, RU, TJ, TM), European patent (AT, BE, CH, CY, DE, DK, ES, FI, FR, GB, GR, IE, IT, LU, MC, NL, PT, SE, TR), OAPI patent (BF, BJ, CF, CG, CI, CM, GA, GN, GQ, GW, ML, MR, NE, SN, TD, TG)

— of inventorship (Rule 4.17(iv)) for US only

Published:

— with international search report

For two-letter codes and other abbreviations, refer to the "Guidance Notes on Codes and Abbreviations" appearing at the beginning of each regular issue of the PCT Gazette.

GRINDING ELEMENT AND GRINDER STONE

[0001] The invention relates to a grinding element, which can be arranged on the outer surface of a frame of a grinder stone used to defiber wood, the grinding element comprising at least one grinding segment made of grinding ceramic material, and fastening means for fastening the element.
5

[0002] The invention further relates to a grinder stone for defibering wood, comprising a cylindrical frame, grinding segments made of grinding ceramic material and arranged on the outer circumference of the grinder stone, and a shaft, around which the grinder stone is arranged to be rotated during grinding.
10

[0003] Wood is typically ground into fibres by means of grinding machines, where logs are pressed against the surface of a rotating grinder stone. Water is simultaneously sprayed to purify and cool the grinder stone. The stone makes the wood fibre matrix vibrate, whereafter the wood fibres are released from the logs to provide a pulp suspension.
15

[0004] The frame of the grinder stone is usually made of concrete, but steel frames have also been developed. A grinding surface of the grinder stone consists of separate ceramic grinding segments attached to the frame. The grinding segments are attached by various mechanisms, which press each segment separately against the outer circumference of the grinder stone. During use, the grinding segments are subjected to a force, which acts parallel to the tangent of the grinder stone and tends to detach the segments. Furthermore, rotating the grinder stone subjects each segment to a centrifugal force, wherefore the segments must be firmly secured.
20

[0005] Due to different thermal expansion coefficients of the ceramic segment, the frame of the grinder stone, and the fastening bolts, the prior art teaches fastening bolts, which can be used to compensate for varying dimensions resulting from changes in the temperature. However, such bolts are rather complicated and therefore also expensive. Furthermore, it is possible to place semi-spherical washers between the bolt and the segment in order that the stresses resulting from the fastening will be distributed more evenly in the ceramic segment and the segment will thus be able to withstand the fastening forces. Another problem with the present arrangements is that the fastening forces subject the ceramic segment to compression stress, which can break the segment usually from below the washer. It is thus necessary to restrict the fastening force, which in some cases can lead to insufficient fastening
25
30
35

of the segment. During grinding, such a loose segment starts vibrating and will be damaged. The ceramic materials used in grinding are highly wear-resistant and hard, yet brittle. However, in practice grinding segments cannot be manufactured from more resistant ceramic materials, since the ceramic material
5 used in grinding of wood must be of a particular type and sufficiently porous to provide a desired grinding effect. Also, quality characteristics set for mechanical pulp require use of the present grinding ceramic materials.

[0006] Yet another problem with the present grinding segments is that replacing the segments is difficult and slow.

10 [0007] An objective of the present invention is to provide a new and improved grinding element and grinder stone for defibering wood.

[0008] A grinding element according to the invention is characterized in that the grinding element comprises a fastening frame with a first surface and a second surface opposite to the first surface, the first surface being
15 arrangeable against the frame of the grinder stone, that the area of the second surface of the fastening frame is greater than the area of an individual grinding segment, that two or more grinding segments are fastened by means of bonding agent to the second surface of the fastening frame, such that the grinding segments cover together substantially the entire second surface of the grinding
20 element and form a grinding surface of the element, and that the fastening frame of the grinding element is provided with fastening means for fastening the element to the frame of the grinder stone.

[0009] Further, a grinder stone according to the invention is characterized in that the outer circumference of the grinder stone is provided with
25 substantially adjacent grinding elements, which constitute a grinding surface of the stone, that each grinding element comprises a substantially planar fastening frame with a first surface and a second surface opposite to the first surface, the first surface being arranged against the frame of the grinder stone, that two or more grinding segments are fastened by means of bonding agent to the
30 second surface of the fastening frame, such that said grinding segments cover together substantially the entire second surface of the grinding element and form a grinding surface, and that the grinding element is fastened to the frame of the grinder stone by fastening means provided in the fastening frame.

[0010] According to a basic idea of the invention, two or more grinding
35 segments manufactured of grinding ceramic material are attached by means of bonding agent to the fastening frame of the grinding element in order

to form a grinding surface of the element. The area of an individual grinding segment is smaller than the area of the fastening frame, wherefore several grinding segments are required to cover the outer surface of the fastening frame. The fastening frame is preferably a substantially planar element. Grinding elements formed in this manner are positioned adjacent to one another on the outer circumference of the frame of the grinder stone so as to form a desired grinding surface. Each element is fastened by one or more fastening means to the stone's frame. Since the grinding element comprises several smaller and lighter grinding segments than previously, the centrifugal force acting on an individual segment is lower than in the prior art arrangements. Furthermore, small segments are easier to manufacture than large segments, since small segments are not subjected to such high stresses as large segments during the firing of the ceramic material. Correspondingly, changes in the temperature during use, and the resulting stresses can be controlled better in small segments. Also, the area of fastening of the segments with respect to the segment's weight is greater than previously, which guarantees tight fastening of the segment. Compared to grinding segments that are fastened individually, the grinding element according to the invention can be installed in a substantially faster and easier manner. Another advantage is that a sufficiently high fastening force can be selected without a risk of damage to the ceramic segment.

[0011] Furthermore, a basic idea of a preferred embodiment of the invention is that the fastening frame of the grinding element is made of plastic. The fastening frame can also be provided with a firm fastening sleeve made of metal or the like, which is arranged in connection with a fastening hole of the grinding element and transmits the fastening force of a fastening bolt to the frame of the grinder stone. It is thus possible to select a sufficiently high fastening force without a risk of damage to the plastic frame. The plastic frame can be manufactured rapidly and at low cost for example by die-casting. The plastic fastening frame is also light and thus easy to handle during assembly. Moreover, since the fastening frame is light, it is subjected to a lower centrifugal force, which reduces the stress on the fastening means.

[0012] Yet another basic idea of a preferred embodiment of the invention is that the grinder stone is formed of at least two grinding elements. A grinding element can be made sufficiently strong for this purpose, even though the element consists of small segments. The segments according to the inven-

tion are fastened as firmly to a small grinding element as to a large grinding element. This arrangement substantially expedites the replacement of elements compared to the replacement of the previous small grinding segments.

5 [0013] It should be mentioned that in the present application the term 'grinder stone' refers to the stone's frame and the assembly of the grinding elements and fastening means arranged thereto.

[0014] The invention will be described in more detail in the accompanying drawings, in which

10 Figure 1 shows schematically a grinding apparatus, where a grinding segment according to the invention can be used,

Figure 2 is a schematic end view of a prior art grinder stone,

Figure 3 is a schematic side view of a part of the prior art grinder stone,

15 Figure 4 is a schematic top view of a grinding element according to the invention,

Figures 5 to 9 are schematic sectional views of grinding elements according to the invention, viewed from the direction of the stone shaft, and

Figure 10 is a schematic end view of a grinder stone according to the invention.

20 [0015] Figure 1 shows a grinding apparatus for detaching fibres from logs 1 or some other similar wood material by means of a rotating cylindrical grinder stone 2. The logs 1 are pressed by feeder means, such as feed cylinders 3, from a feed chamber 4 against the outer surface of the grinder stone 2. Water is simultaneously supplied from nozzles 6 to a grinding chamber 5. The fibre that has been released from the logs accumulates with the
25 sprayed water in a grinder pit 7 at the bottom of the grinding chamber and is conducted therefrom to subsequent processing steps. The grinding apparatus is considered fully known to a person skilled in the art, wherefore the structure and operation thereof do not have to be described in more detail herein.

30 [0016] Figure 2 shows, in a simplified manner, a prior art grinder stone 2, which rotates around a shaft 8. The grinder stone comprises a preferably metal cylindrical frame 9, the outer circumference of which is provided with individual grinding segments 10 typically made of ceramic, a suitable ceramic mixture or some other corresponding material, and positioned adjacent
35 to one another. The segments thus constitute a grinding surface 30 of the grinder stone that processes the wood. Figure 3 is a side view of a part of the

grinder stone. The segments are typically rather large and heavy, and thus attaching the segments firmly to the frame of the grinder stone has proved to be difficult. If a large and heavy segment comes off the grinder stone for some reason during use, it can produce serious damage to the grinding apparatus and cause a safety risk. Furthermore, since each segment is separately fastened to the grinder stone, it is difficult to replace segments.

[0017] Figure 4 is a top view of a grinding element 11 according to the invention. The grinding element shown in the figure is rectangular, but it is clear that the shape and the size of the grinding element can vary in each situation. The grinding element comprises a substantially planar fastening frame 12, the first surface 14 of which is positioned against the frame 9 of the grinder stone, and the second, opposite surface 13 of the fastening frame being provided with a sufficient number of grinding segments 10 fastened so as to cover substantially the entire second surface of the element, thus forming together the grinding surface of the element. The area of the second surface 13 of the fastening frame is greater than the area of an individual grinding segment 10, wherefore several, typically 5 to 10 grinding segments are needed per one grinding element. Each segment is manufactured of ceramic or some other corresponding material that is suitable for grinding. The figure shows rectangular segments, but it is clear that the shape and the size of the segments can be selected suitably in each case. If required, the grinding element can comprise segments of various sizes. The joints between the segments are preferably positioned in different locations when viewed at least in one direction, as shown in the figure. The joints between the segments carry with them the wood fibre that has been detached during grinding, and therefore the grinding surface of the segments does not have to be provided with grooves.

[0018] The grinding segments are fastened to the second surface of the fastening frame by means of bonding agent 15, wherefore the segments need not be provided with fastening holes, nor do they require mechanical fastening means. The bonding agent can be any suitable plastic material, such as polyphenylene sulphide (PPS), polyether imide (PEI), vinyl ester-polyurethane (VEUH), vinyl ester (VE), polyurethane (PUR), polystyrene (PS), polyamide (PA), and epoxy resins. The bonding agent can also consist of a mixture of polyurethane (PUR) and polyester, or a mixture of some other resins, i.e. a hybrid resin. If required, the bonding agent can be reinforced with fibre or it can contain filler. The fibre reinforcement can consist of any suitable fibre material,

such as a glass fibre mat or a glass fibre mesh, staple glass fibre, milled glass fibre, kevlar, carbon fibre or some other suitable fibre material. The filler can be aluminium oxide, silica sand, kaolin, talc or some other suitable filler. It is also possible to use e.g. metal solder or different concrete types as bonding agent.

5 **[0019]** In addition to the bonding agent 15 acting as an adhesive between the segment 10 and the fastening frame 12, the plastic layer of bonding agent can also damp vibration and percussive loads at the bottom of the segments. Furthermore, the layer of bonding agent can compensate for varying dimensions resulting from the thermal expansion of the segment and the
10 fastening frame. As shown in Figures 5 and 6, a proportion of the transverse sides of the segments can also be provided with layers of bonding agent, beginning from the bottom of the segments.

[0020] Figures 5 and 6 show that the second surface 13 of the fastening frame is curved. The first surface 14 of the fastening frame is straight, or
15 it is alternatively curved and corresponds to the shape of the frame 9 of the grinder stone. In the first case, the outer circumference of the stone's frame is provided with planar surfaces, parallel to the shaft of the stone, for fastening the elements. One or more fastening holes 16 extend through the fastening frame, and fastening bolts 17 are supplied through the holes to fasten the
20 grinding element 11 to the frame of the grinder stone. In Figure 5, the frame of the grinding element is made of steel, concrete or some other similar material capable of receiving the fastening forces. Furthermore, the fastening frame can be provided with a thread, and the fastening bolt is screwed from the side of the stone's frame. Other fastening means, such as suitable wedge mecha-
25 nisms, can also be used.

[0021] In Figure 6, the fastening frame 12 of the grinding element is made of plastic, such as polyphenylene sulphide (PPS), polyether imide (PEI), vinyl ester-polyurethane (VEDUH), vinyl ester (VE), polyurethane (PUR), polystyrene (PS), polyamide (PA), and epoxy resins. If required, the bonding agent
30 can be reinforced with fibre or it may contain filler. The plastic fastening frame is also provided with fastening sleeves 18, made of metal or some other firm material, which coincide with the fastening holes 16, and the fastening bolts 17 being arranged through the fastening sleeves. The fastening bolt tightens the fastening sleeve to the frame of the grinder stone, wherefore the plastic fasten-
35 ing frame will not be subjected to any significant compression stresses resulting from the fastening. The fastening sleeve can be a separate element to be

installed in place after the fastening frame has been cast. Alternatively, the fastening sleeve is arranged in the mould and the fastening frame is cast around it, so that the sleeve will be integrated with the frame. In such a case the fastening sleeve can be provided with protrusions 19, which ensure that the sleeve is properly fastened to the plastic material. Furthermore, since the fastening bolt and the fastening sleeve are preferably manufactured of the same material, which is typically steel, thermal expansion is under control and no expensive special bolts are needed to balance the varying dimensions. It is also possible to arrange both the fastening sleeve and the grinding segments in the mould and to thereafter cast the fastening frame from the plastic material. The plastic material of the fastening frame thus acts as bonding agent, which joins the segments to the fastening frame. The casting can be for example die-casting.

[0022] Figure 7 shows that the first surface 14 of the fastening frame of the grinding element can be curved, if the frame 9 of the grinder stone is cylindrical. Figure 8 further shows one or more protrusions 50 formed on the first surface of the fastening frame and arranged in a recess formed in the frame 9 of the grinder stone, so that the forces acting on the grinding element, such as shear forces, are transmitted via the protrusion to the frame of the grinder stone. Such a locking mechanism based on the shapes also prevents the grinding element from turning with respect to the frame of the grinder stone. Therefore the fastening means of the grinding element will not be subjected to such high stresses, and the fastening will be firm. Alternatively, the first surface of the grinding element can comprise one or more recesses 51, and the outer surface of the stone's frame 9 is thus provided with suitable protrusions. Figure 10 is an end view of a grinder stone according to an embodiment of the invention, where the frame 9 of the grinder stone is cylindrical and the grinding surface is formed of two grinding elements 11 arranged on the outer circumference of the stone.

[0023] The drawings and the related description are only intended to illustrate the inventive idea. The details of the invention can vary within the scope of the claims. Therefore, even though the figures show the invention in connection with a grinder stone of a steel frame, the invention can also be applied in grinder stones with a frame of concrete. Furthermore, the shape and the size of the grinding element can be selected suitably in each case.

CLAIMS

1. A grinding element, arrangeable on the outer surface of a frame of a grinder stone used to defiber wood, the grinding element comprising
at least one grinding segment made of grinding ceramic material,
fastening means for fastening the segment,
a fastening frame with a first surface and a second surface opposite to the first surface, the first surface being arrangeable against the frame of the grinder stone,
wherein the fastening frame of the grinding element is provided with fastening means for fastening the element to the frame of the grinder stone,
wherein the fastening means for fastening the segment is a bonding agent,
wherein said grinding segment is fastened to said second surface of said fastening frame, and wherein said second surface is substantially covered,
wherein the area of the second surface of the fastening frame is greater than the area of an individual grinding segment at which abuts against the second surface and,
wherein two or more grinding segments fastened to the second surface of the fastening frame, such that the grinding segments cover together substantially the entire second surface of the grinding element and form a grinding surface of the element.
2. A grinding element according to claim 1 wherein the fastening frame is a substantially planar piece.
3. A grinding element according to claim 1 or 2, wherein the fastening frame is made of plastic.
4. A grinding element according to claim 3, wherein the fastening frame further comprises a fastening hole, and a fastening sleeve is provided in connection with the fastening hole, and a fastening bolt is arranged to press the fastening sleeve to the frame of the grinder stone.
5. A grinding element according to any one of claims 1 to 4, wherein the bonding agent is a plastic material.

6. A grinding element according to any one claims 1 to 4, wherein the bonding agent is a material reinforced with fibre.
7. A grinding element according to claim 5 or 6, wherein at least a proportion of the sides of the grinding segment transverse to the grinding surface is provided with bonding agent.
8. A grinding element according to any one of claims 1 to 7, wherein the first surface of the grinding element comprises at least one protrusion or recess.
9. A grinder stone for defibering wood, comprising
 - a grinder stone frame defining an outer surface and adapted to be rotatable about a shaft and
 - a plurality of grinding elements operably engaged with the outer surface of the grinder stone frame such that the grinding elements cooperate to form a substantially cylindrical grinding surface of the grinder stone, each grinding element comprising:
 - a fastening frame having a first surface configured to operably engage the frame of the grinder stone and an opposed second surface ;
 - a fastening device configured to operably engage the fastening frame and to secure the fastening frame to the grinder stone frame; and
 - a plurality of grinding segments, each defining an area smaller than the second surface of the fastening frame and being comprises of a ceramic grinding material, the grinding segments fastened to the fastening frame with a bonding agent disposed between the grinding segments to the second surface, the grinding segments cooperating to substantially cover the second surface of the fastening frame to form at least a portion of a grinding surface of the grinder stone.
10. A grinder stone according to claim 9, wherein the first surface of the grinding element comprises at least one protrusion or recess , and that the outer surface of the stone's frame is provided with surfaces corresponding to said protrusions or recesses for transmitting the forces produced during grinding from the grinding element to the frame of the grinder stone.

11. A grinder stone according to claim 9 or 10, wherein the grinder stone comprises at least two grinding elements.

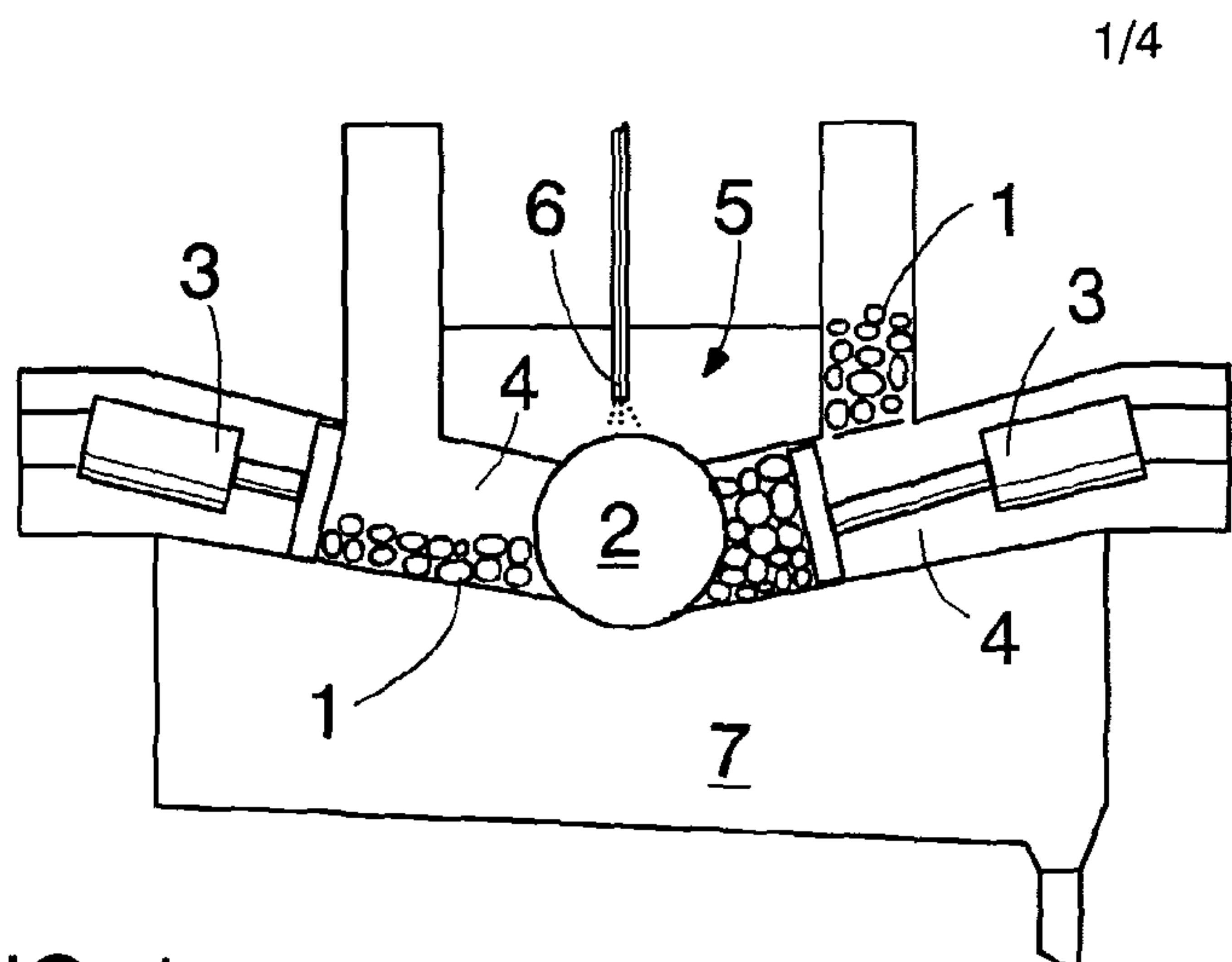
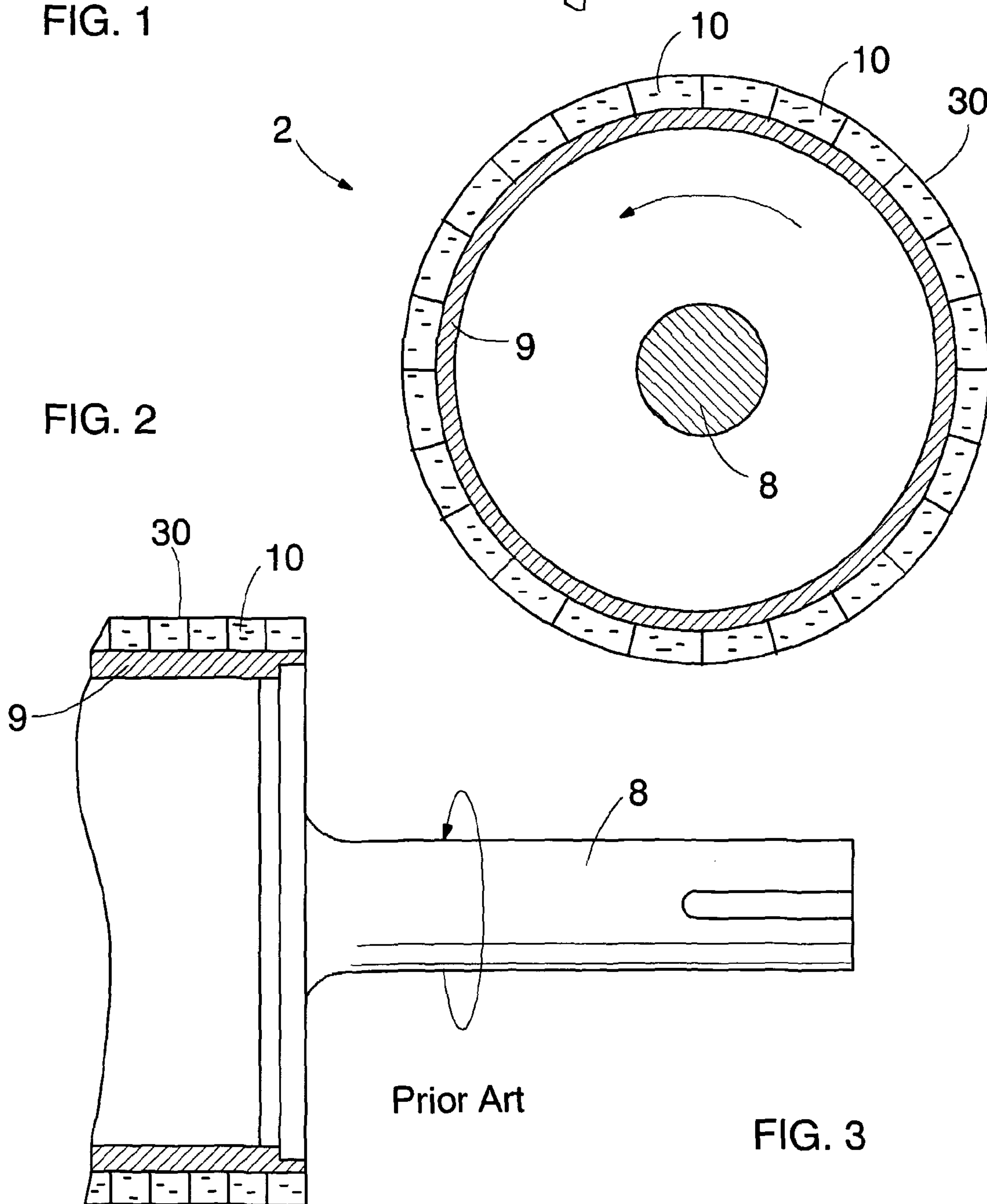

FIG. 1

Prior Art



Prior Art

FIG. 3

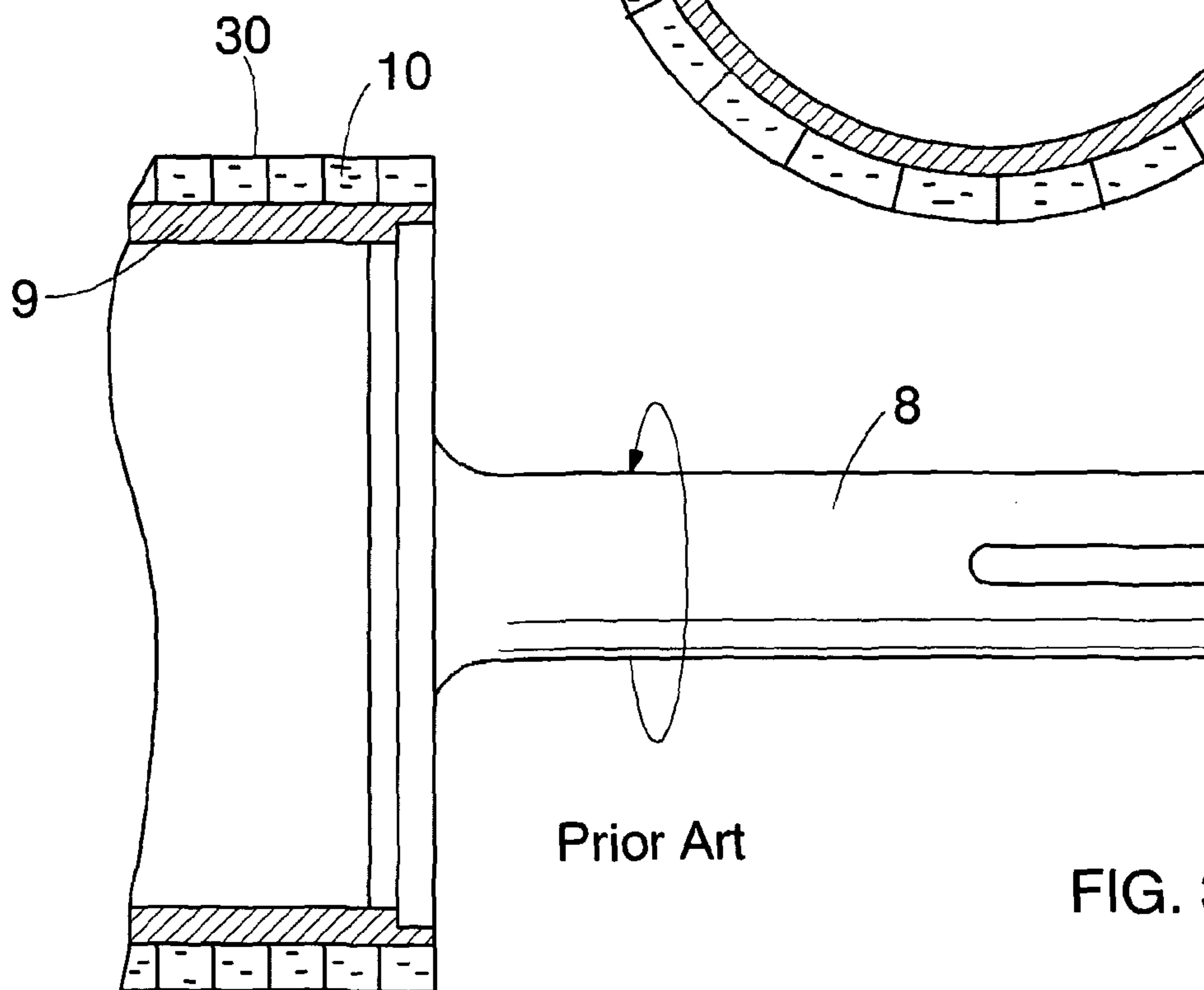

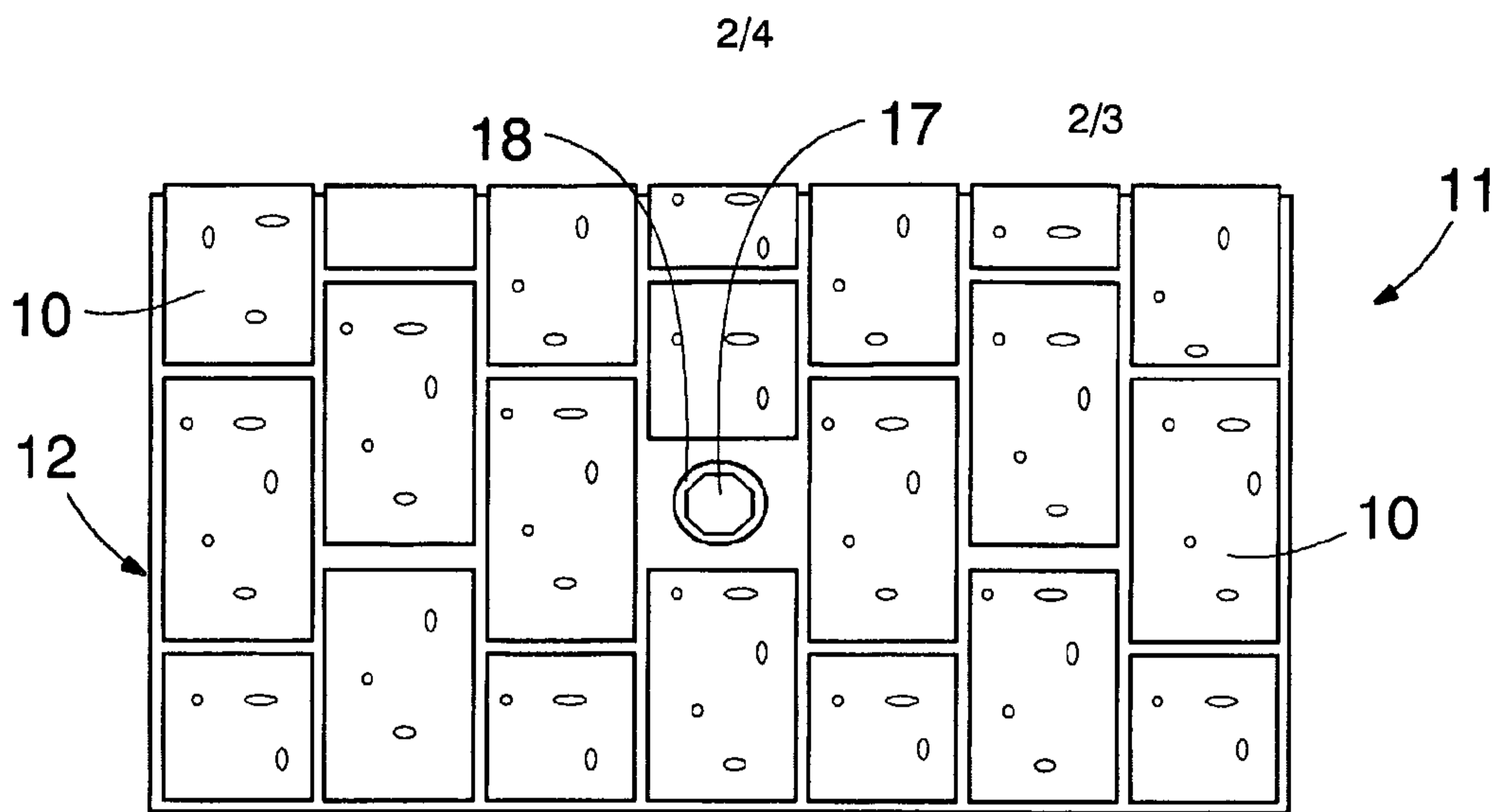

FIG. 4

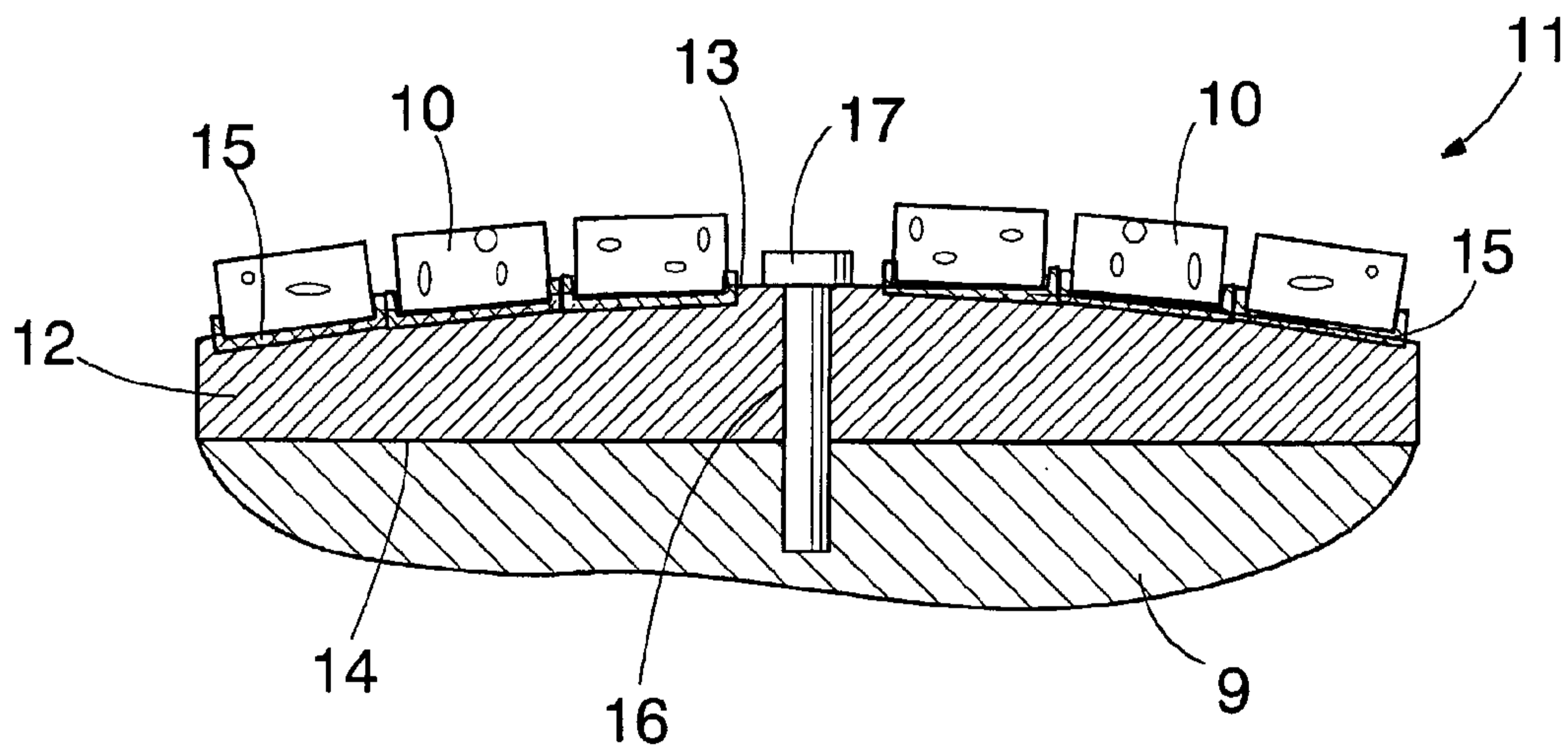

FIG. 5

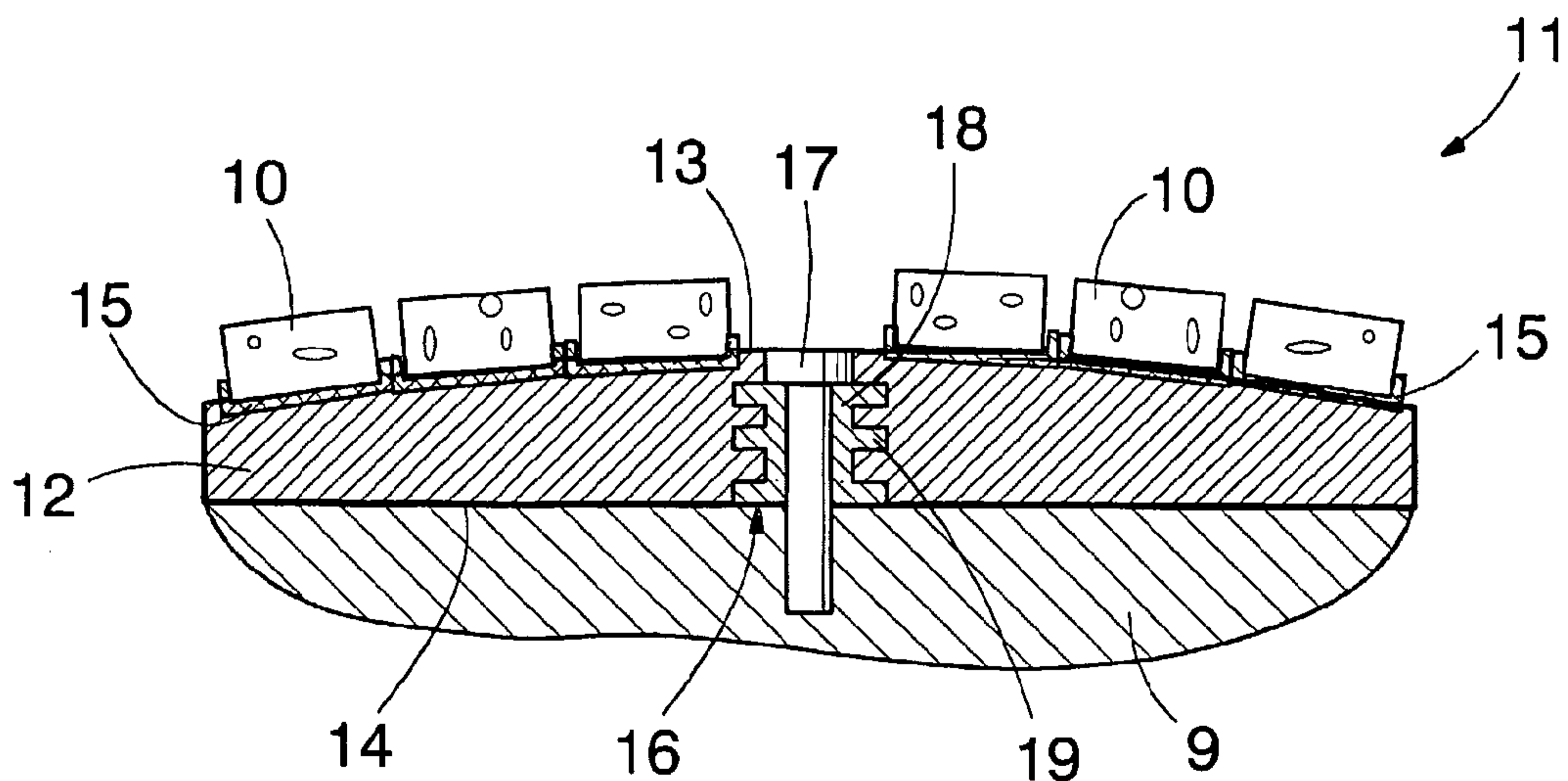

FIG. 6

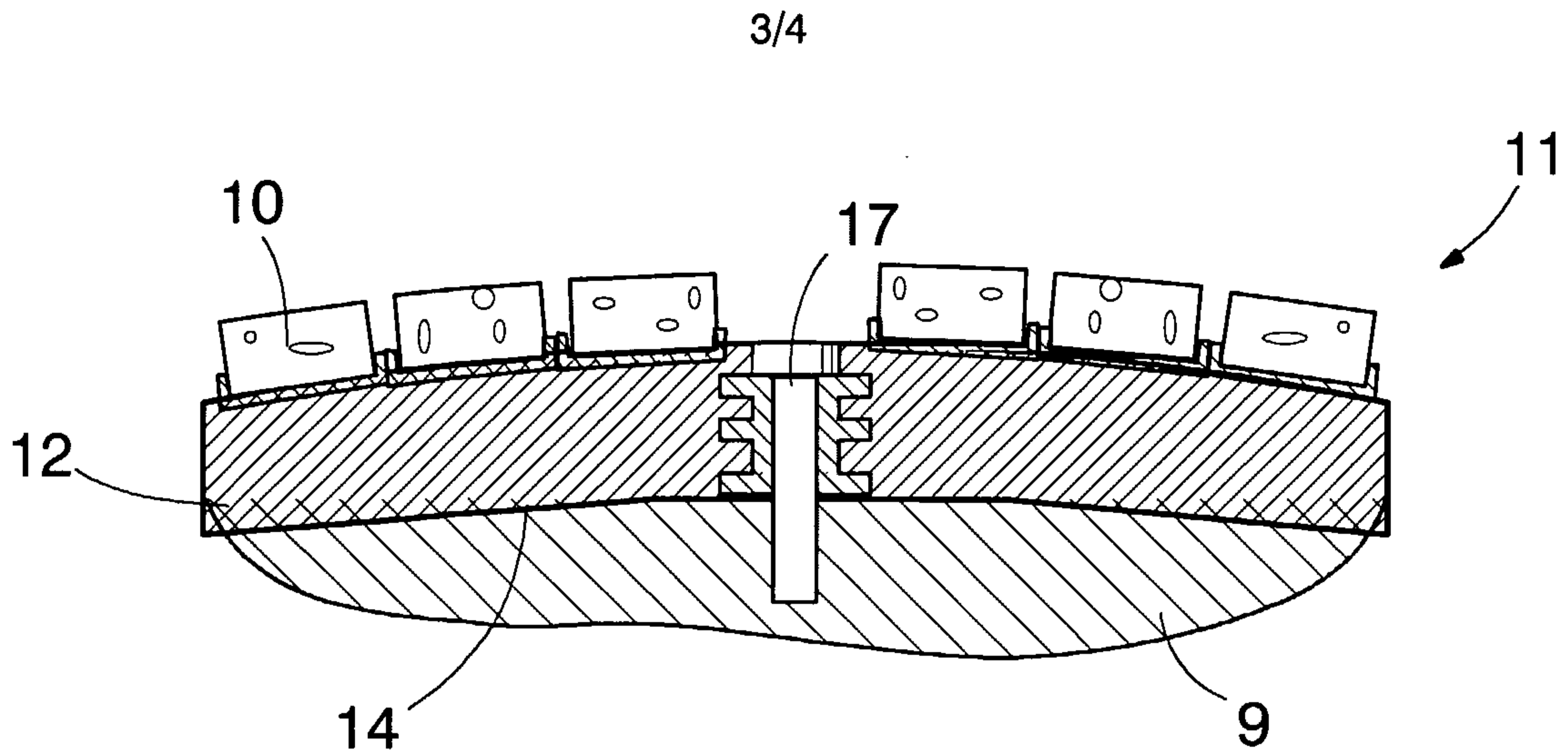

FIG. 7

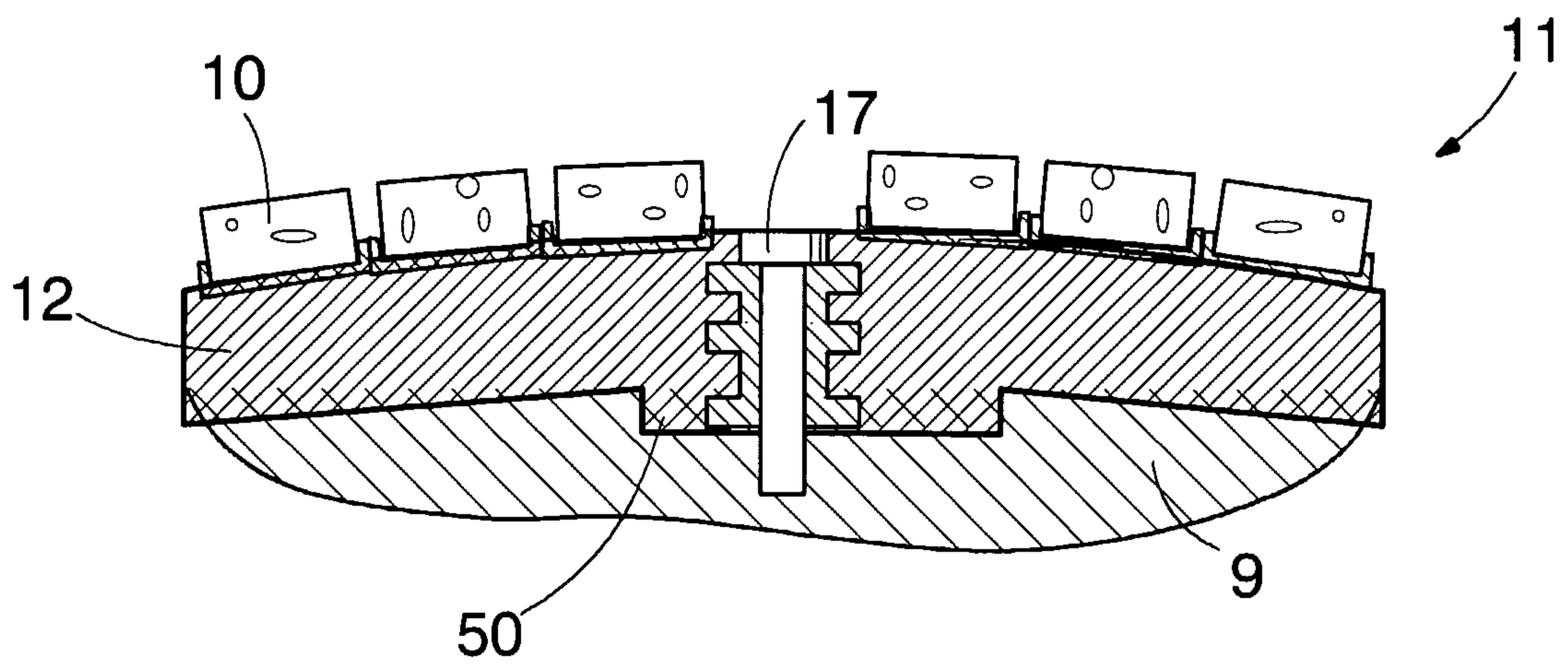

FIG. 8

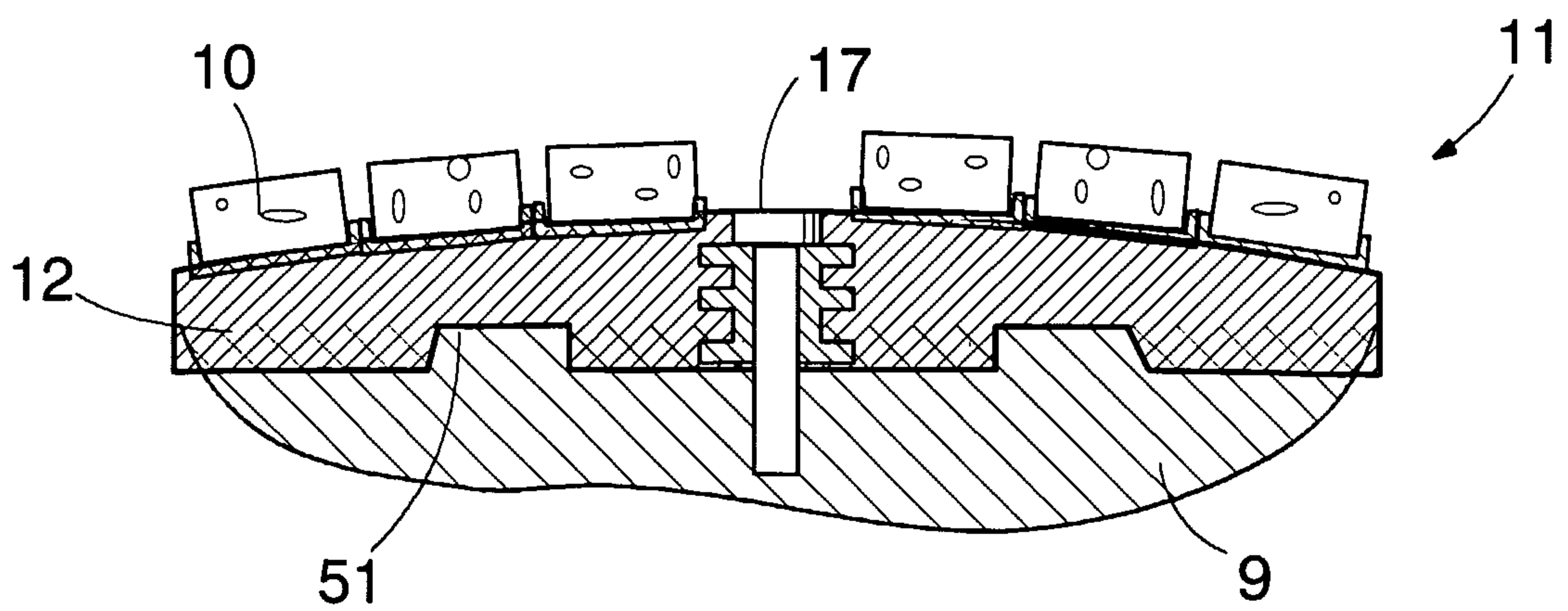

FIG. 9

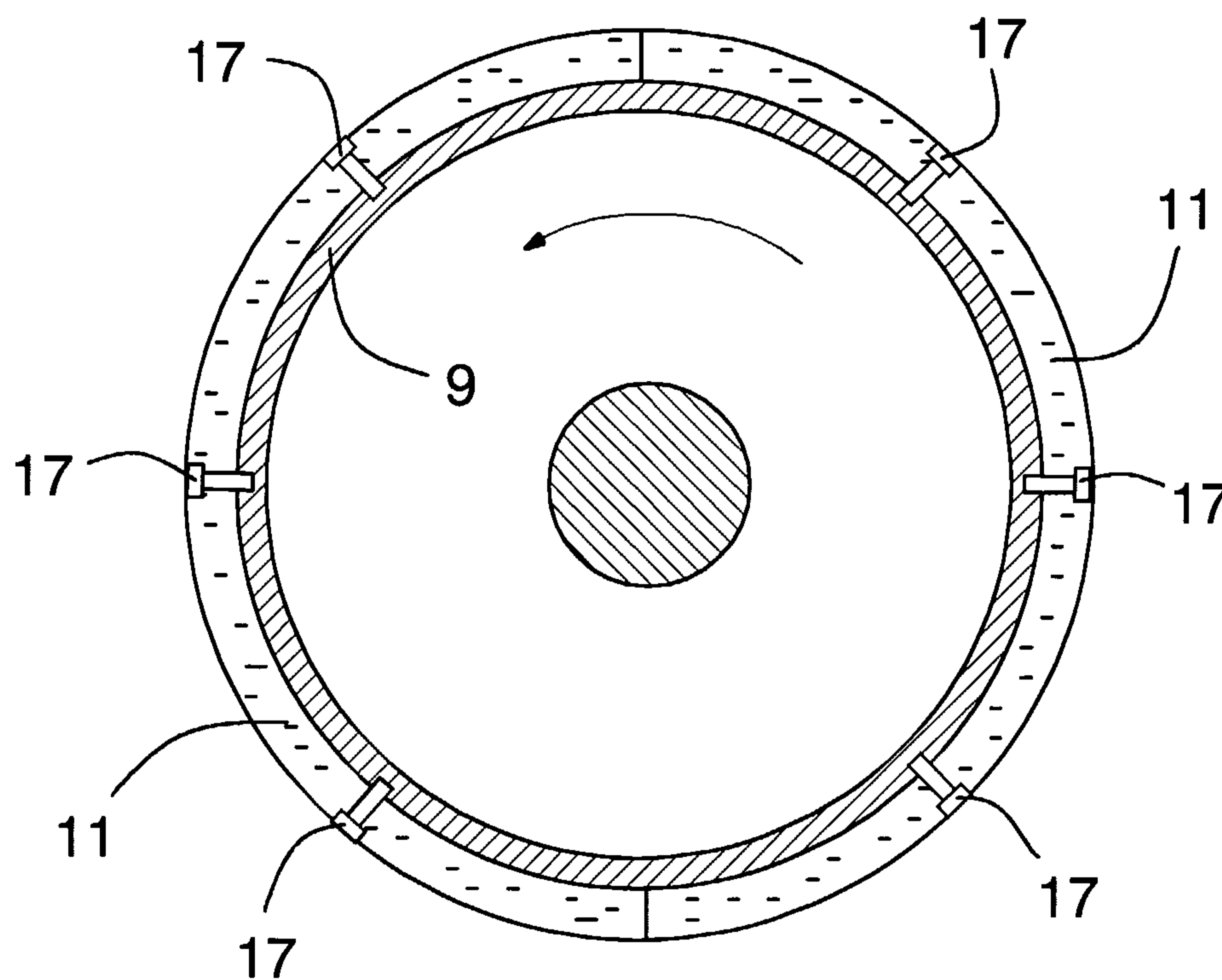

FIG. 10

