



(72) CHUANG, WILLIAM, TW

(71) CHUANG, WILLIAM, TW

(51) Int.Cl.<sup>7</sup> F16C 19/04, F16C 33/60

(54) ROULEMENT

(54) BEARING ASSEMBLY

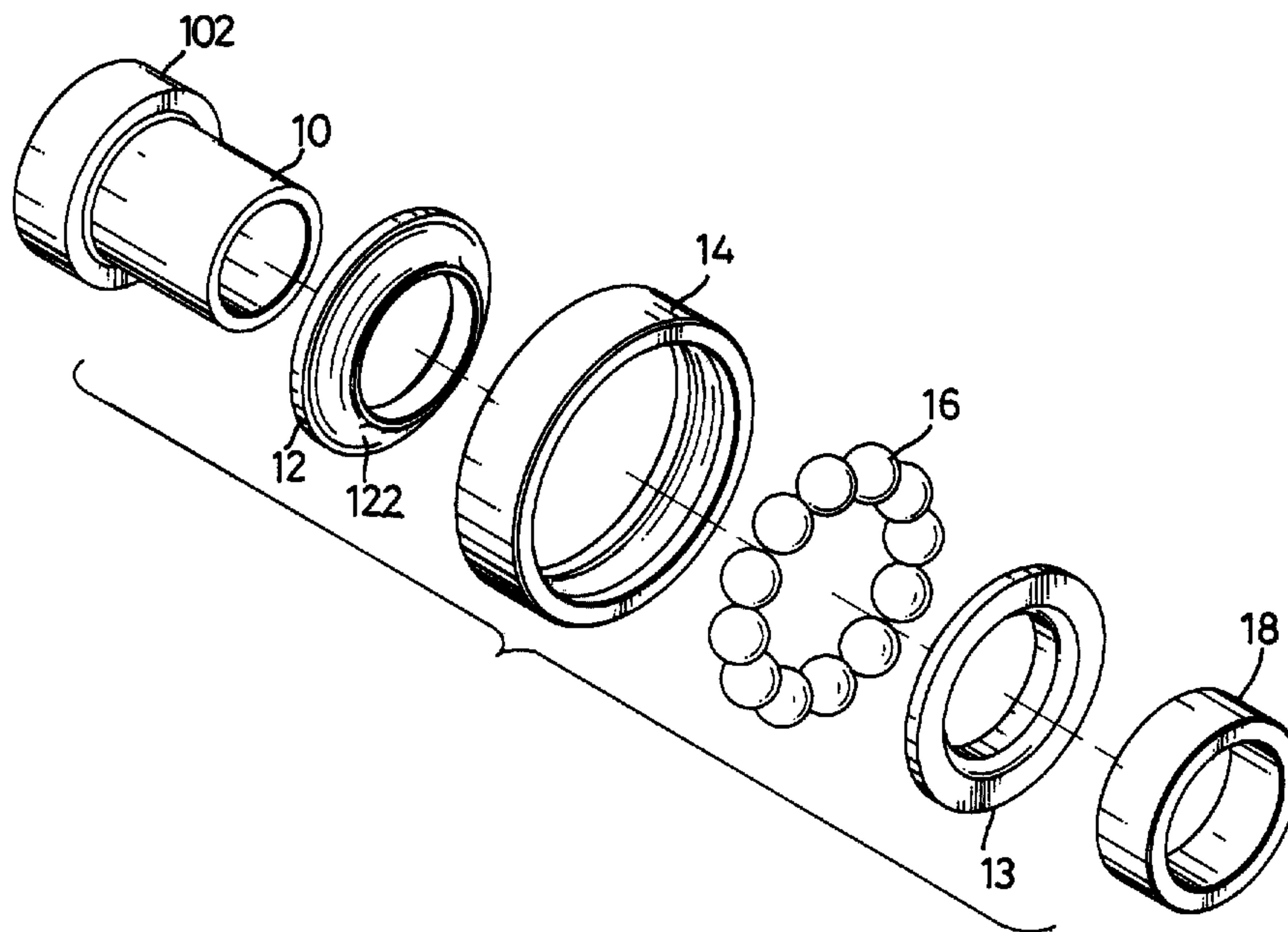

(57) A bearing assembly with at least one row of balls is disclosed. The bearing assembly has a shaft tube, at least one pair of bearing covers pressed onto the shaft tube, a concave surface formed in facing sides of each of the bearing covers, a row of balls received in the corresponding concave surfaces of the pair of bearing covers and a race arranged on the outer periphery of the row of balls to receive them. The bearing assembly can be arranged with multiple rows of balls to improve the ability to bear a large load between the rotating and stationary members.

**BEARING ASSEMBLY****ABSTRACT OF THE DISCLOSURE**

1  
2  
3 A bearing assembly with at least one row of balls is disclosed. The bearing assembly has a  
4 shaft tube, at least one pair of bearing covers pressed onto the shaft tube, a concave surface  
5 formed in facing sides of each of the bearing covers, a row of balls received in the  
6 corresponding concave surfaces of the pair of bearing covers and a race arranged on the outer  
7 periphery of the row of balls to receive them. The bearing assembly can be arranged with  
8 multiple rows of balls to improve the ability to bear a large load between the rotating and  
9 stationary members.

10 Fig. 2

1 **BEARING ASSEMBLY**

2 **BACKGROUND OF THE INVENTION**

3 1. Field of the Invention

4 The present invention relates to a bearing assembly, and more particularly to a bearing  
5 assembly with multiple rows of balls mounted therein to bear a heavier load.

6 **BRIEF DESCRIPTION OF THE DRAWINGS**

7 Fig. 1 is a perspective view of a bearing assembly with one row of balls in accordance  
8 with the present invention;

9 Fig. 2 is an exploded perspective view of the bearing assembly in Fig. 1;

10 Fig. 3 is a cross sectional plan view of the bearing assembly in Fig. 1;

11 Fig. 4 is an exploded perspective view of a bearing assembly with two rows of balls in  
12 accordance with the present invention;

13 Fig. 5 is a cross sectional plan view of the bearing assembly in Fig. 4;

14 Fig. 6 is a cross sectional plan view of an embodiment of a bearing with multiple rows of  
15 balls in accordance with the present invention;

16 Fig. 7 is a cross sectional plan view of another embodiment of a bearing with multiple  
17 rows of balls in accordance with the present invention;

18 Fig. 8 is a cross sectional plan view of a bearing with one row of balls in accordance with  
19 the prior art; and

20 Fig. 9 is a cross sectional plan view of a bearing with two rows of balls in accordance  
21 with the prior art.

22 2. Description of Related Art

23 Referring to Fig. 8, a ball bearing in accordance with the prior art comprises a bearing  
24 cover (40), a positioning collar (44), multiple balls (46) and a bearing race (42). The  
25 positioning collar (44) is co-axially mounted on the bearing cover (40). A row of balls (46) is

1 located between the bearing cover (40) and the positioning collar (44) in a bearing race (42),  
2 such that the race (46) can rotate relative to the bearing cover (40) and the positioning collar  
3 (44) with very little friction. However, because the ability to bear a load depends on the  
4 number of rows of balls (46), the conventional bearing with a single row of balls (46) is not  
5 able to bear a large load between the rotating and stationary members. In addition, the  
6 conventional bearing is difficult to manufacture and assemble because the structure of the  
7 bearing cover (40) is complex.

8 Referring to Fig. 9, a bearing with two rows of balls (54) in accordance with the prior art  
9 comprises a tubular member (50) and a sleeve (52) mounted on the outer periphery of the  
10 tubular member (50). A row of balls (54) is received between the tubular member (50) and  
11 the sleeve (52) on each end of the sleeve (52), and a holder (56) is mounted to abut each row  
12 of balls (54) to maintain their position. The sleeve (52) can rotate relative to the tubular  
13 member (50) with little friction, and a bearing with two rows of balls (54) is achieved.

14 However, although the conventional bearing with two rows of balls (54) can bear a  
15 heavier load better than that of the conventional bearing with a single row of balls, the  
16 conventional bearing with two rows of balls (54) still lacks the ability to bear a very large  
17 load. In addition, there is no supporting effect between the rows of balls (54) when they are a  
18 long distance apart.

19 To overcome the shortcomings, the present invention tends to provide an improved  
20 bearing assembly to mitigate or obviate the aforementioned problems.

## 21 SUMMARY OF THE INVENTION

22 The main objective of the invention is to provide a bearing assembly with a shaft tube, at  
23 least one pair of bearing covers with a row of balls between the covers and a race so that the  
24 bearing assembly can be arranged with multiple rows of balls to improve the ability to bear a  
25 large load.

1 Other objects, advantages and novel features of the invention will become more apparent  
2 from the following detailed description when taken in conjunction with the accompanying  
3 drawings.

#### 4 DETAILED DESCRIPTION OF PREFERRED EMBODIMENT

5 Referring to Figs. 1-3, the bearing assembly in accordance with the present invention  
6 comprises a shaft tube (10), a bearing housing, bearing balls (16) and a securing collar (18). A  
7 pair of annular bearing covers (12, 13) for each row of bearing balls (16) is press fit on the  
8 outer periphery of the shaft tube (10). A concave surface (122, 132) is defined in the facing  
9 side of each of the bearing covers (12, 13). A row of balls (16) is received between the  
10 concave surfaces (122, 132) of the pair of bearing covers (12,13). A race (14) with a concave  
11 inner surface corresponding to the curvature of the bearing balls (16) is arranged around the  
12 row of balls (16), such that the race (14) can rotate relative to the shaft tube (10) and the pair  
13 of bearing covers (12, 13) and decrease the friction between the rotating and stationary  
14 members.

15 In addition, an enlarged positioning end (102) with a diameter larger than that of the  
16 shaft tube (10) is formed on one end of the shaft to abut one of the bearing covers (12), and a  
17 securing collar (18) is pressed onto the other end of the shaft tube (10) to abut the other  
18 bearing cover (13). The bearing covers (12, 13) are more securely mounted on the shaft tube  
19 (10) and rotate together.

20 Referring to Figs. 4 and 5, two pairs of bearing covers (12, 13) are mounted on the shaft  
21 tube (10), and each pair of bearing covers (12, 13) has one row of balls (16) held between the  
22 pair of covers (12, 13). A spacer collar (20) is mounted on the shaft tube (10) between the two  
23 pairs of collars (12, 13) to maintain their separation from each other. With such an  
24 arrangement, the bearing assembly can bear a load better than that of the conventional  
25 bearing (shown in Fig. 8) with a single row of balls. In addition, because the shaft tube (10),

1 the bearing covers (12, 13), the race (14), the securing collar (18) and the spacer collar (20)  
2 are tubular or annular members with a simple shape, the efficiency of manufacturing and  
3 assembling the bearing assembly is improved.

4 With reference to Fig. 6, another embodiment of a bearing assembly in accordance with  
5 the present invention has multiple pairs of bearing covers (12, 13) and a row of bearing balls  
6 (14) between each pair of covers (12, 13). A spacer collar (20) is arranged between adjacent  
7 pairs of bearing covers (12, 13). With reference to Fig. 7, another embodiment has the  
8 adjacent pairs of bearing covers (12, 13) abutting each other. Consequently, the bearing  
9 assembly can be arranged with multiple rows of balls (16) so as to improve the ability to bear  
10 a huge load.

11 In addition, a sleeve (22) is mounted on the outer periphery of all of the races (14), such  
12 that all of the races (14) can rotate relative to the shaft tube (10) simultaneously. Furthermore,  
13 multiple recesses (222) are defined in the outer periphery of the sleeve (22) to improve the  
14 bond between the sleeve (22) and the member to which the sleeve (22) is mounted.

15 Even though numerous characteristics and advantages of the present invention have been  
16 set forth in the foregoing description, together with details of the structure and function of the  
17 invention, the disclosure is illustrative only, and changes may be made in detail, especially in  
18 matters of shape, size, and arrangement of parts within the principles of the invention to the  
19 full extent indicated by the broad general meaning of the terms in which the appended claims  
20 are expressed.

1 The embodiment of the invention in which an exclusive property or privilege is claimed are  
2 defined as follows:

3 1. A bearing assembly comprising:

4 a shaft tube;

5 at least one pair of bearing covers pressed onto said shaft tube, a concave surface formed  
6 on a face of each of the bearing covers, and a row of balls received in said concave surfaces of  
7 said pair of bearing covers; and

8 a race formed to enclose said row of balls therein;

9 wherein said concave surfaces of each of the bearing covers corresponds to each other.

10 2. The bearing assembly as claimed in claim 1, wherein an enlarged end with a diameter  
11 larger than that of said shaft tube is formed on one end of said shaft tube, and a securing collar  
12 is pressed onto the other end of said shaft tube.

13 3. A bearing assembly comprising:

14 a shaft tube;

15 at least two pairs of bearing covers pressed onto said shaft tube, a concave surface  
16 formed on a face of each of the bearing covers, a row of balls received between the pairs of  
17 bearing covers and a race arranged around each row of balls between each said pair of bearing  
18 covers,

19 wherein said concave surface of each pair of bearing covers corresponds to each other.

20 4. The bearing assembly as claimed in claim 3, wherein a spacer collar mounted on said  
21 shaft tube is located between adjacent pairs of bearing covers.

22 5. The bearing assembly as claimed in claim 3 further comprising a sleeve securely  
23 mounted on the outer periphery of all of said races.

24 6. The bearing assembly as claimed in claim 5, wherein multiple recesses are defined on  
25 the outer periphery of said sleeve.

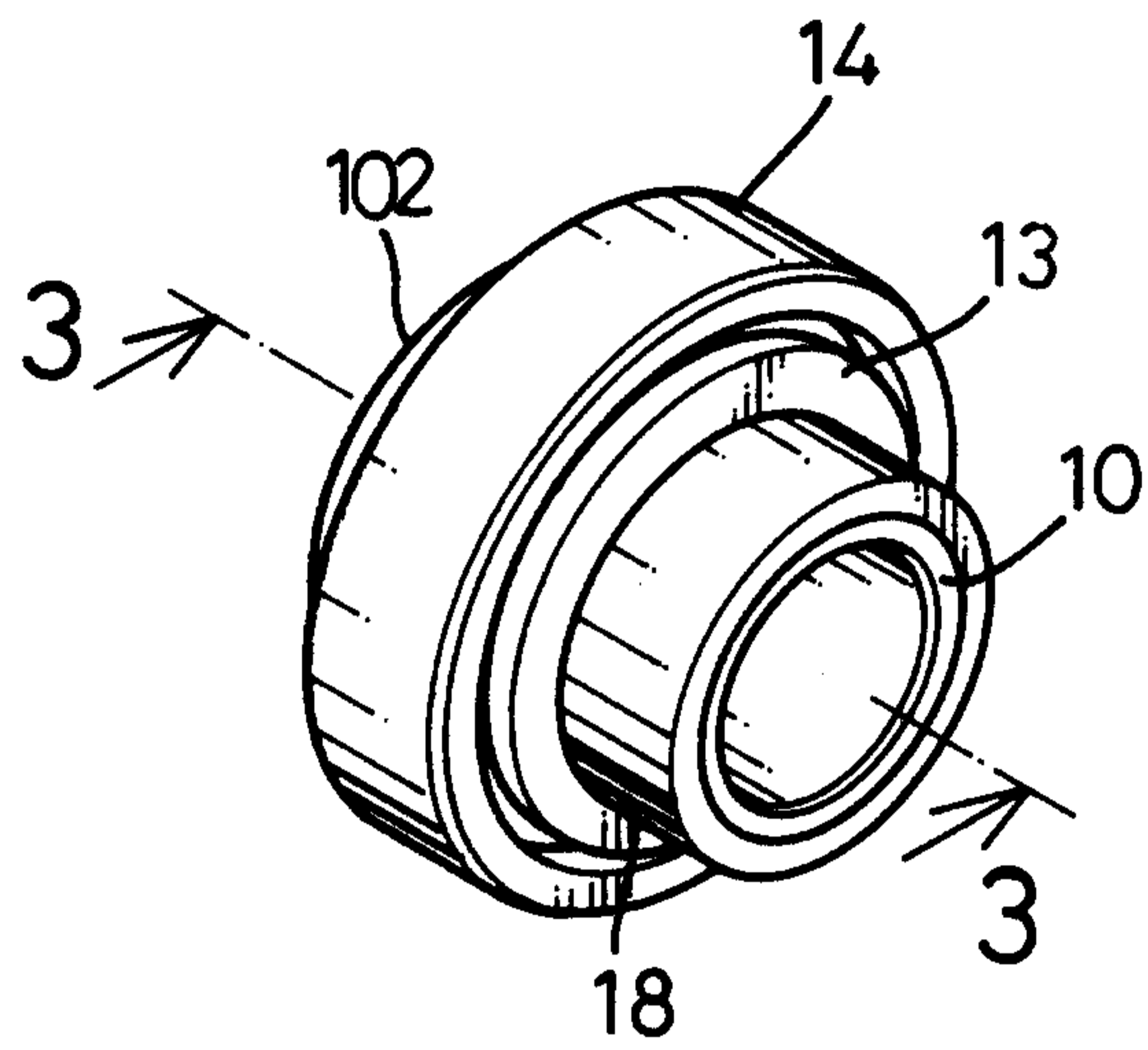

FIG. 1

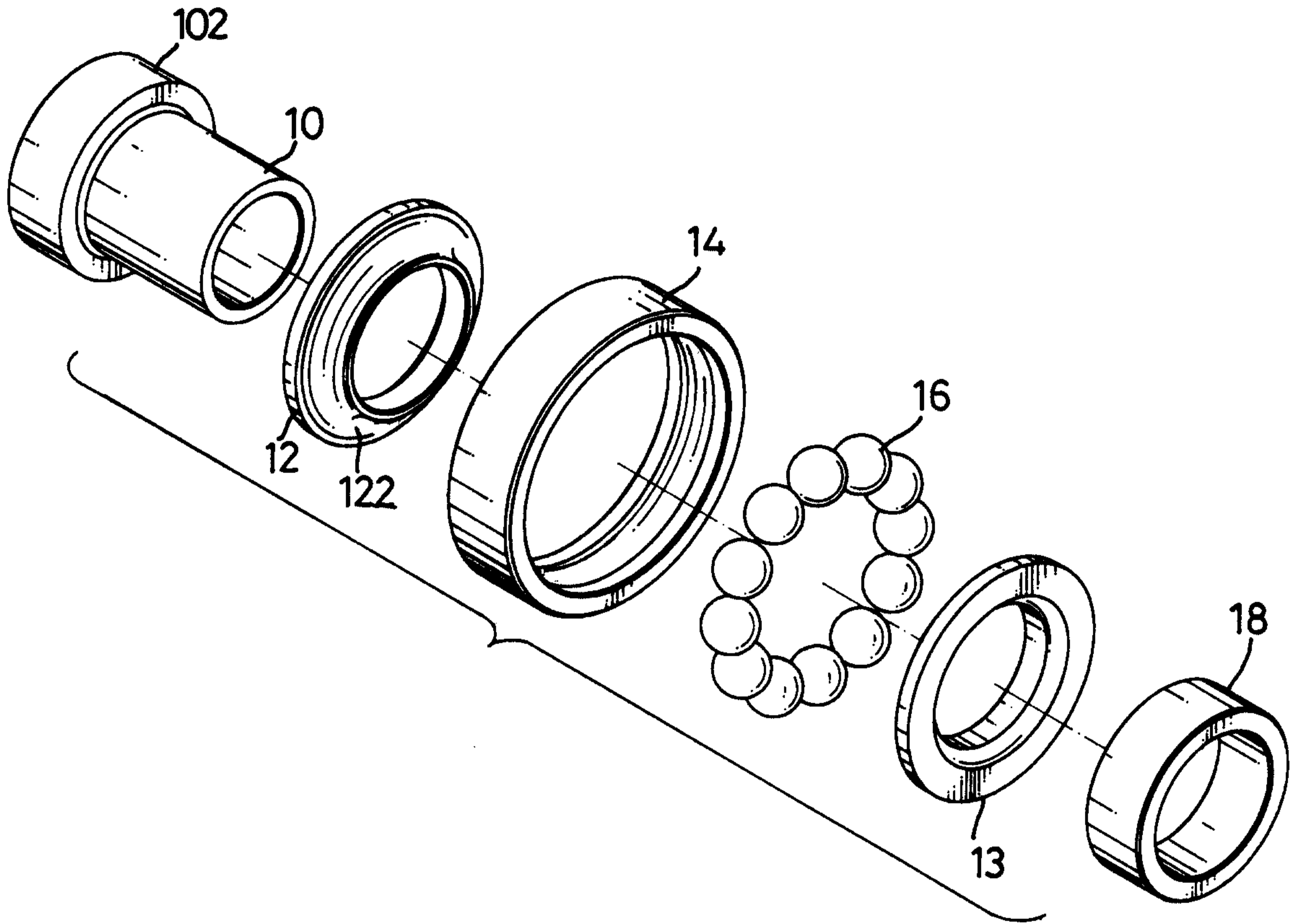

FIG. 2

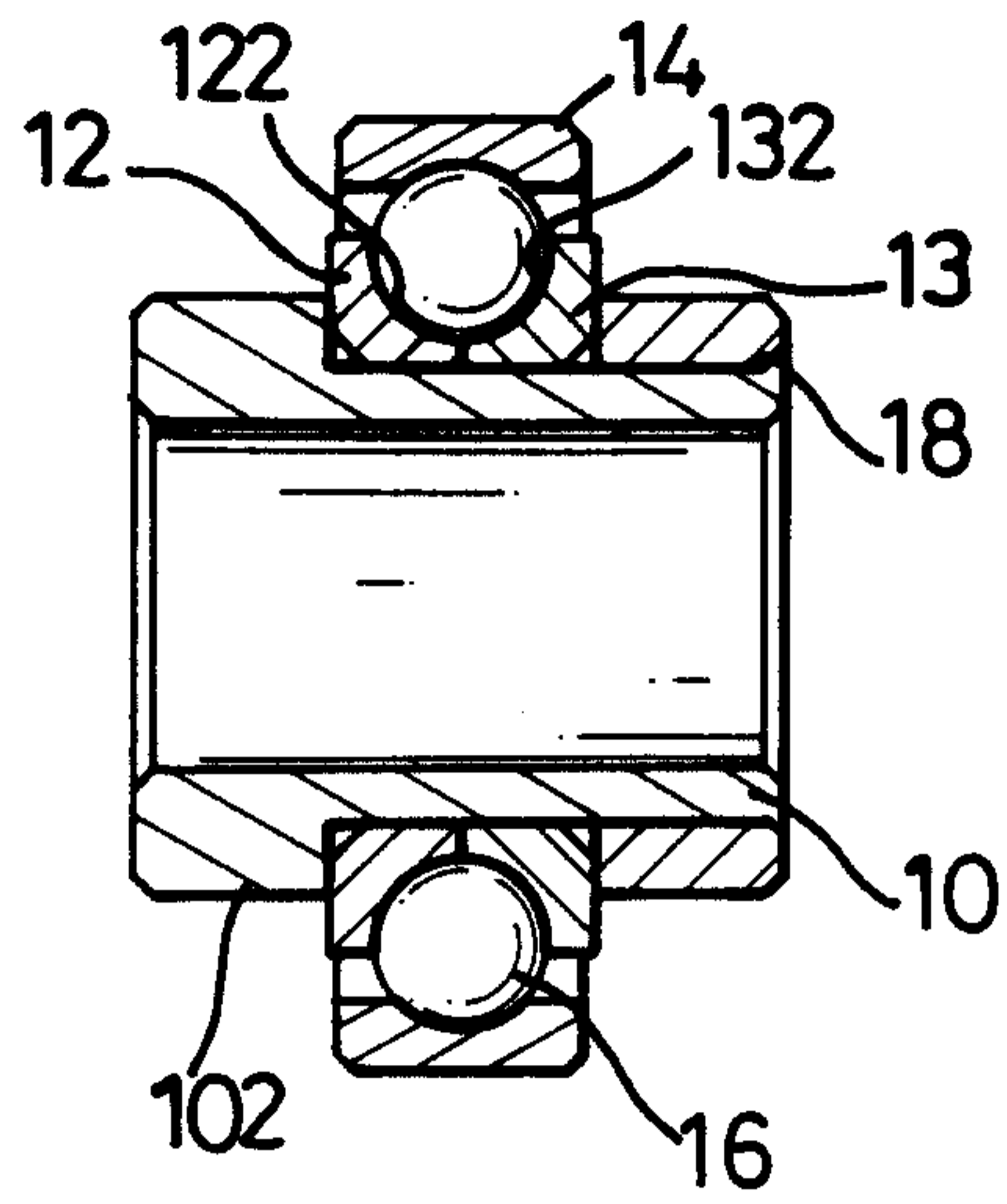

FIG. 3

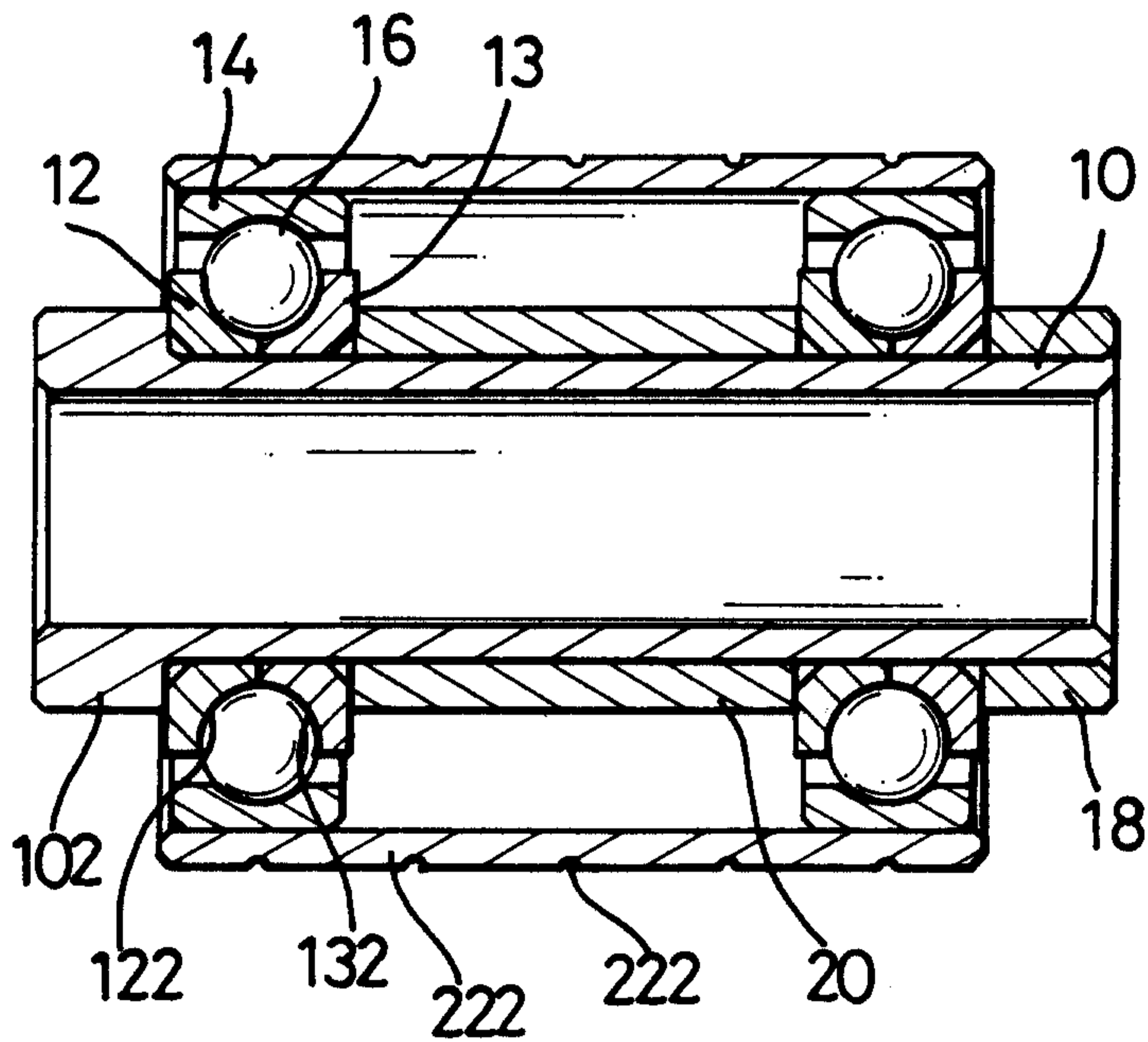
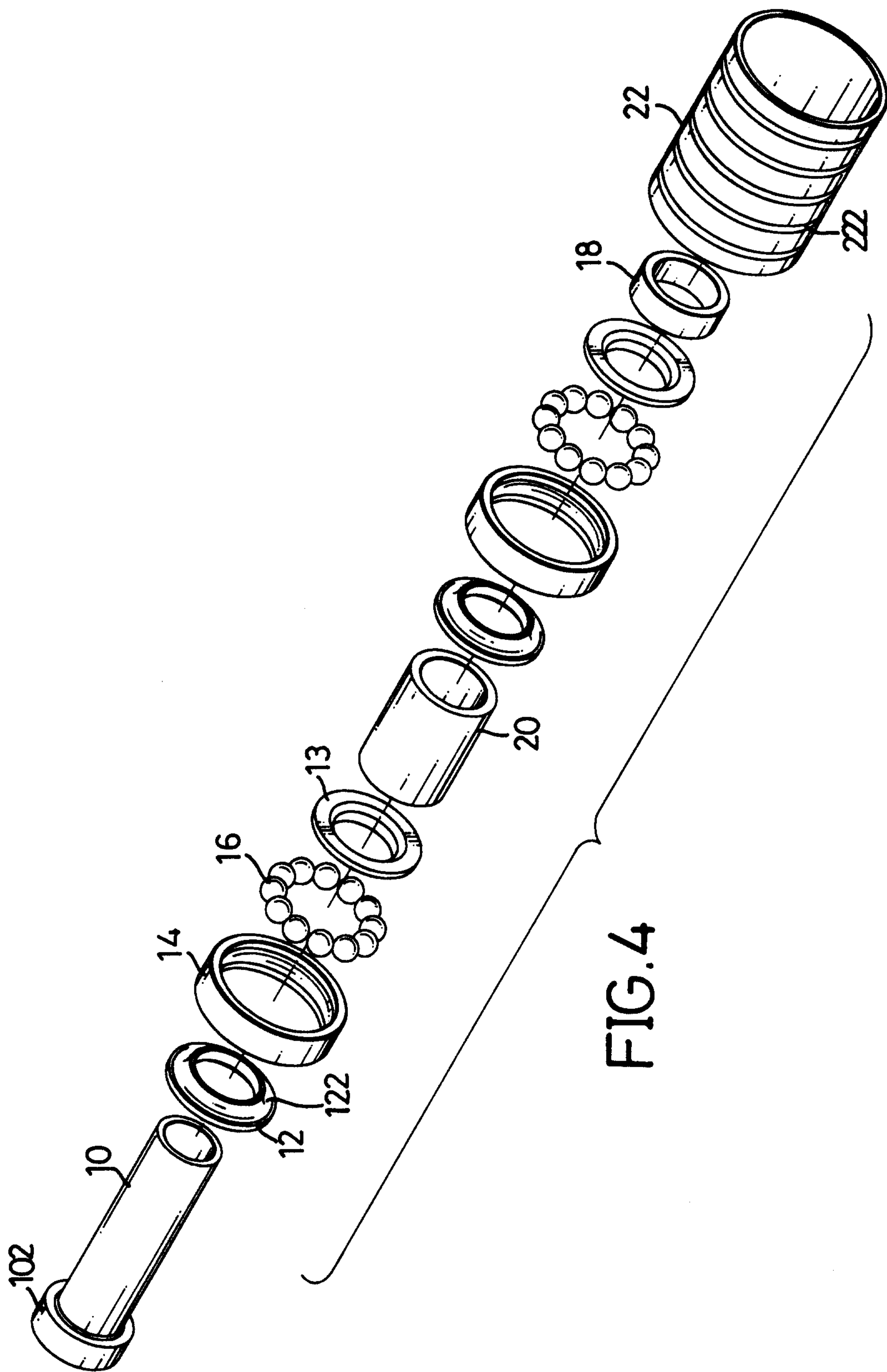

FIG. 5



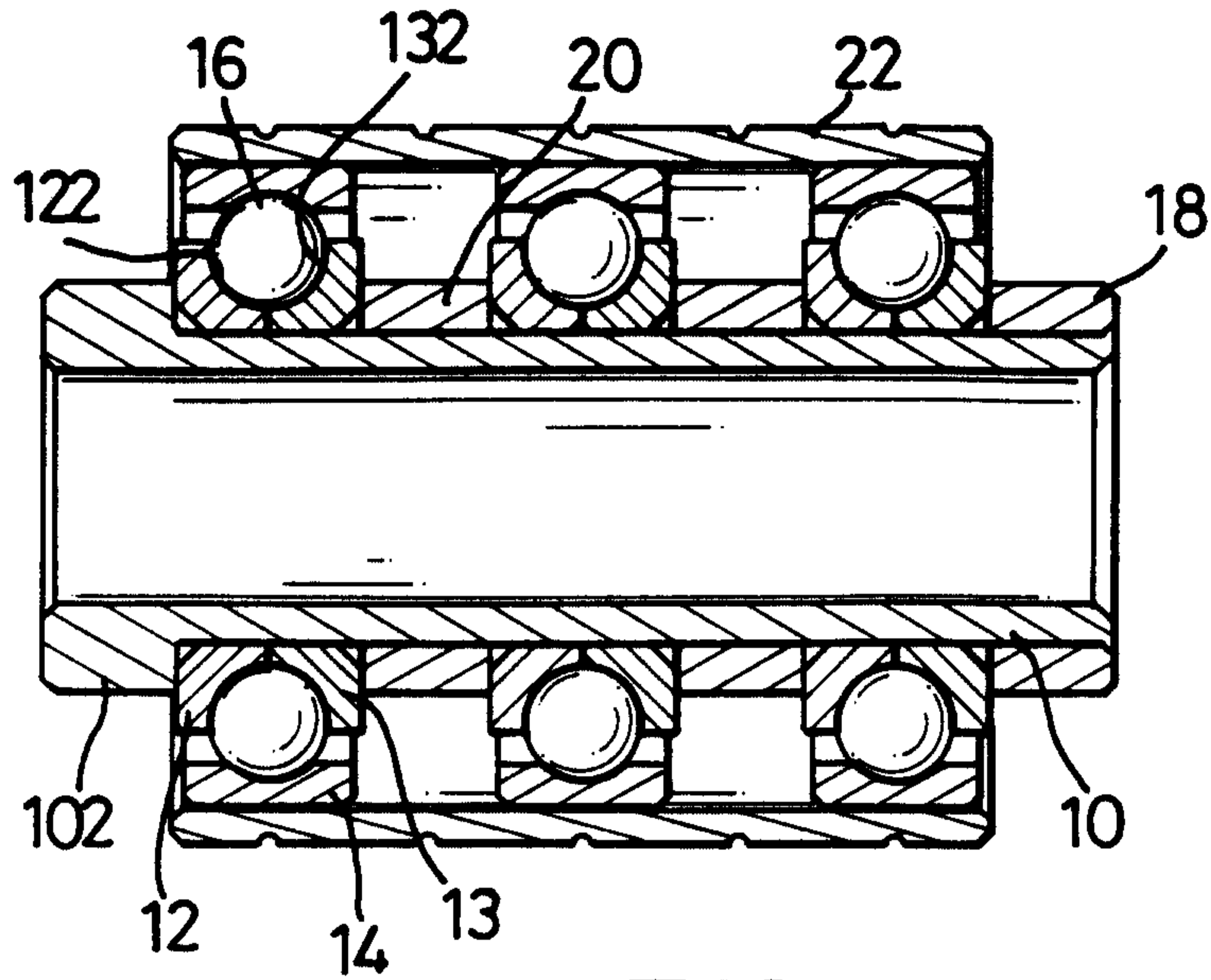

FIG. 6

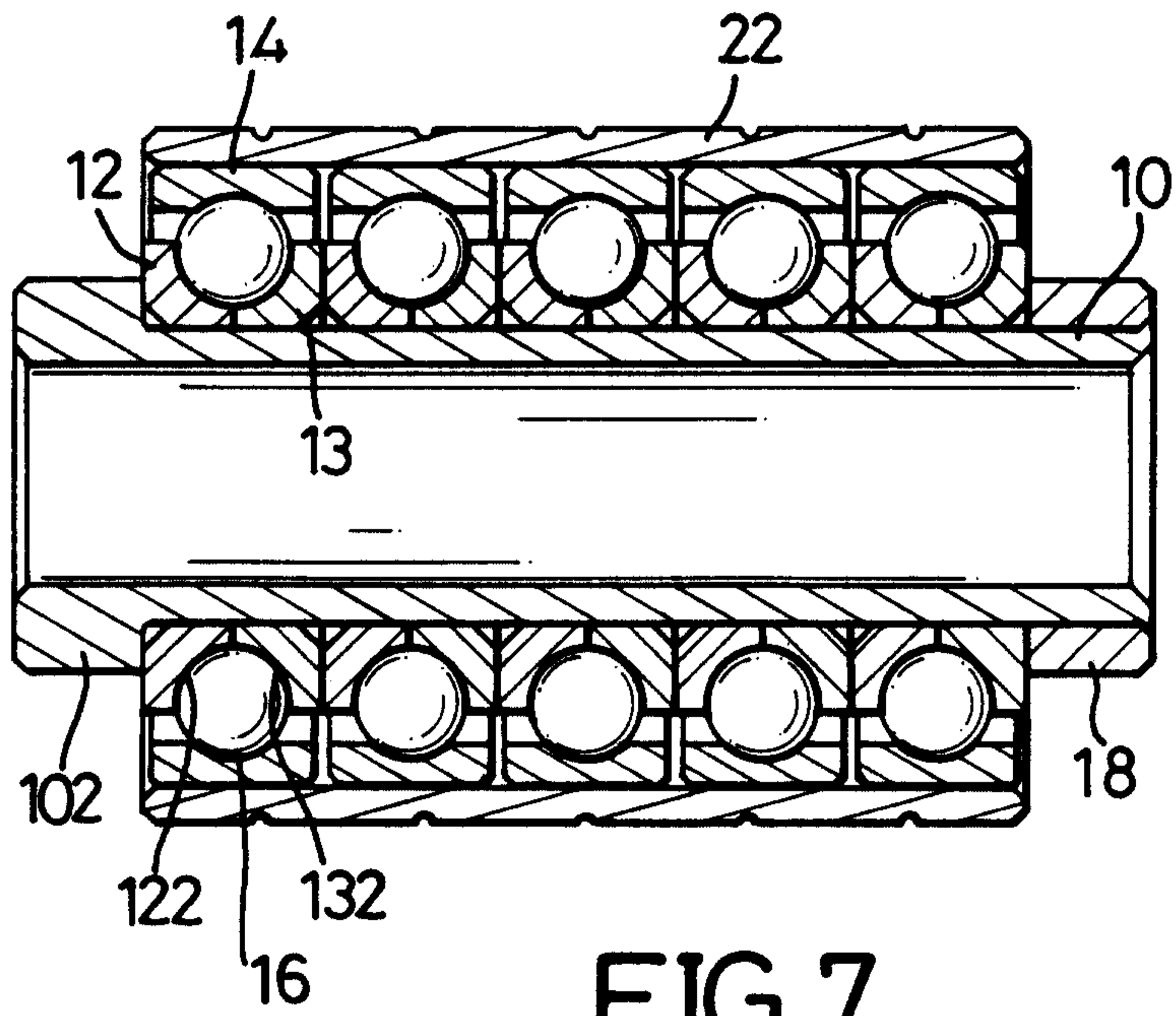

FIG. 7

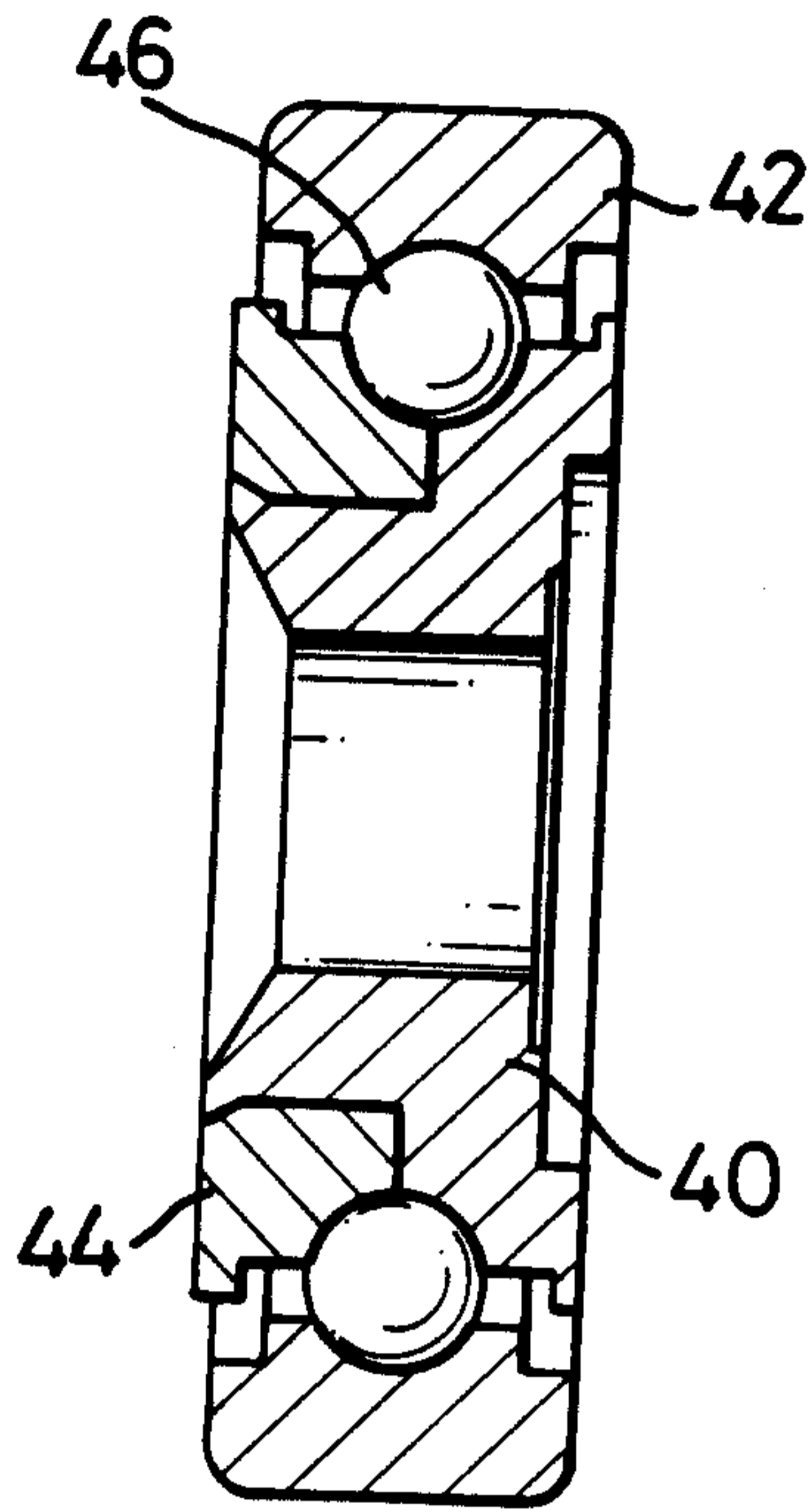

FIG.8  
PRIOR ART

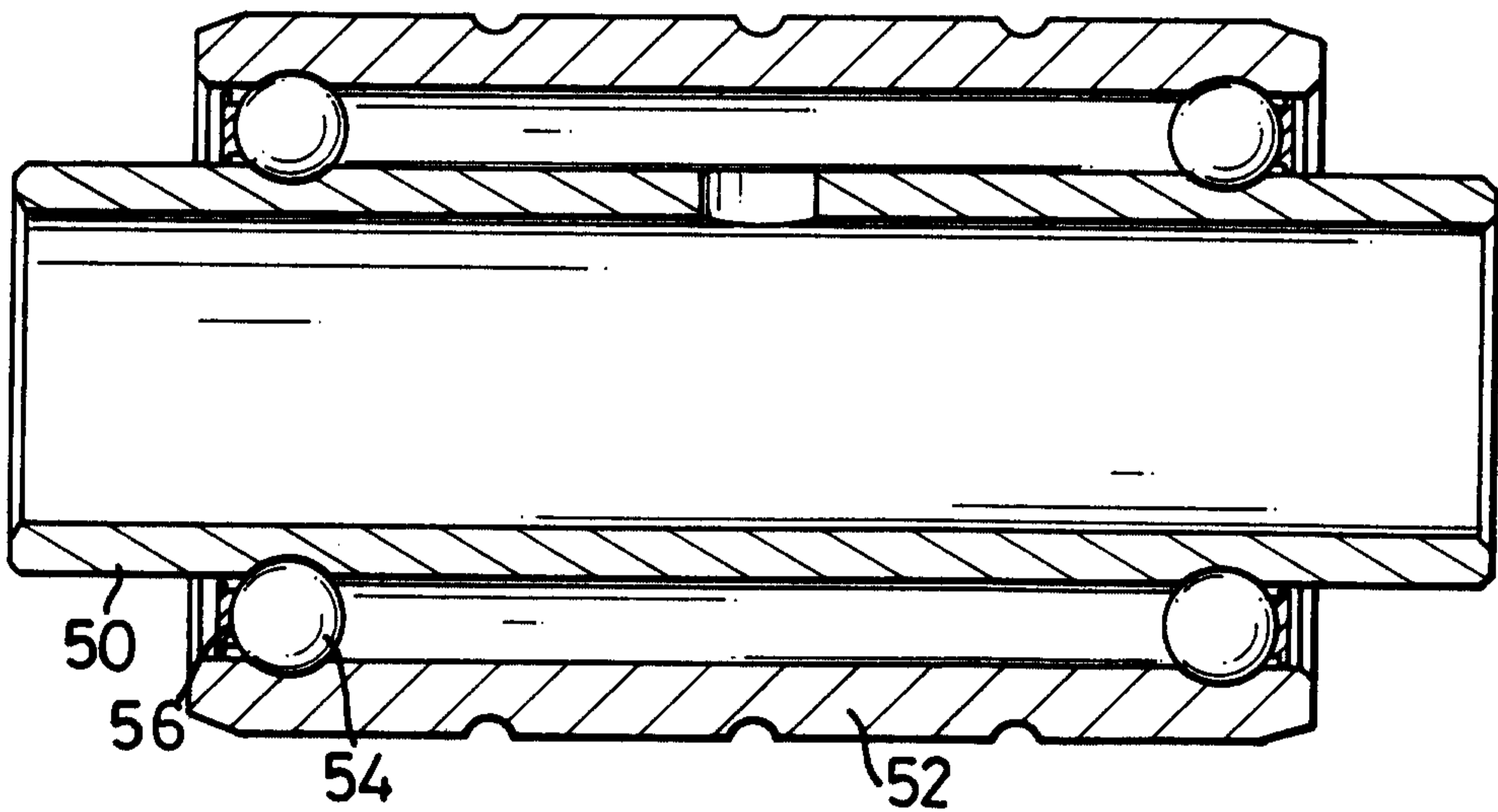

FIG.9  
PRIOR ART

