



(51) International Patent Classification:  
*H04N 13/00* (2006.01)

Group, 999 Brannan Street, San Francisco, California  
94103-4938 (US).

(21) International Application Number:  
PCT/US2012/032857

(81) Designated States (unless otherwise indicated, for every kind of national protection available): AE, AG, AL, AM, AO, AT, AU, AZ, BA, BB, BG, BH, BR, BW, BY, BZ, CA, CH, CL, CN, CO, CR, CU, CZ, DE, DK, DM, DO, DZ, EC, EE, EG, ES, FI, GB, GD, GE, GH, GM, GT, HN, HR, HU, ID, IL, IN, IS, JP, KE, KG, KM, KN, KP, KR, KZ, LA, LC, LK, LR, LS, LT, LU, LY, MA, MD, ME, MG, MK, MN, MW, MX, MY, MZ, NA, NG, NI, NO, NZ, OM, PE, PG, PH, PL, PT, QA, RO, RS, RU, RW, SC, SD, SE, SG, SK, SL, SM, ST, SV, SY, TH, TJ, TM, TN, TR, TT, TZ, UA, UG, US, UZ, VC, VN, ZA, ZM, ZW.

(22) International Filing Date:  
10 April 2012 (10.04.2012)

(25) Filing Language: English

(26) Publication Language: English

(30) Priority Data:  
61/476,198 15 April 2011 (15.04.2011) US

(71) Applicant (for all designated States except US): **DOLBY LABORATORIES LICENSING CORPORATION** [US/US]; 100 Potrero Avenue, San Francisco, California 94103-4813 (US).

(84) Designated States (unless otherwise indicated, for every kind of regional protection available): ARIPO (BW, GH, GM, KE, LR, LS, MW, MZ, NA, RW, SD, SL, SZ, TZ, UG, ZM, ZW), Eurasian (AM, AZ, BY, KG, KZ, MD, RU, TJ, TM), European (AL, AT, BE, BG, CH, CY, CZ, DE, DK, EE, ES, FI, FR, GB, GR, HR, HU, IE, IS, IT, LT, LU, LV, MC, MK, MT, NL, NO, PL, PT, RO, RS, SE, SI, SK, SM, TR), OAPI (BF, BJ, CF, CG, CI, CM, GA, GN, GQ, GW, ML, MR, NE, SN, TD, TG).

(72) Inventors; and  
(75) Inventors/Applicants (for US only): **WELSH, Richard J.** [GB/GB]; c/o Dolby Europe Limited, Interface Business Park Office A, Wootton Bassett Wiltshire SN4 8QJ (GB). **RALPH, Christian** [GB/GB]; c/o Dolby Limited Europe, Interface Business Park Office A, Wootton Bassett Wiltshire SN4 8QJ (GB).

**Declarations under Rule 4.17:**

— as to the identity of the inventor (Rule 4.17(i))

(74) Agents: **KONSTANTINIDES, Konstantinides** et al.; **DOLBY LABORATORIES, INC.**, Intellectual Property

[Continued on next page]

(54) Title: SYSTEMS AND METHODS FOR RENDERING 3D IMAGES INDEPENDENT OF DISPLAY SIZE AND VIEWING DISTANCE

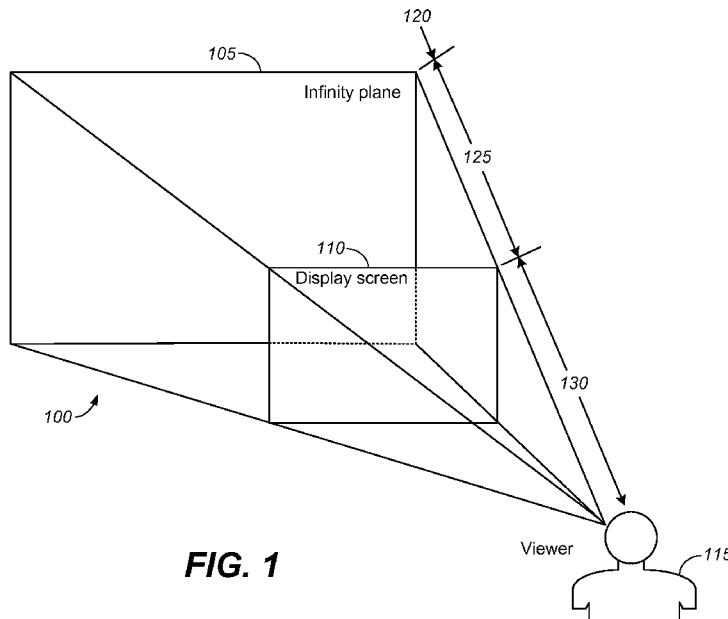

**FIG. 1**

(57) Abstract: Methods and systems for providing and rendering 3D depth information are described. Specifically, the 3D depth information includes z-axis values provided in a normalized percentage format, that defines the position of an object relative to an infinity plane, a display screen, and a viewer, and can be used to render one or more images independent of display screen size and viewing distance.

WO 2012/145191 A1

- *as to applicant's entitlement to apply for and be granted a patent (Rule 4.17(ii))*
- *of inventorship (Rule 4.17(iv))*
- *as to the applicant's entitlement to claim the priority of the earlier application (Rule 4.17(iii))*
- *with international search report (Art. 21(3))*

**Published:**

# **SYSTEMS AND METHODS FOR RENDERING 3D IMAGES INDEPENDENT OF DISPLAY SIZE AND VIEWING DISTANCE**

## **CROSS-REFERENCE TO RELATED APPLICATIONS**

**001** This application claims priority to United States provisional patent application No. 61/476,198 filed 15 April 2011, which is hereby incorporated in its entirety.

## **FIELD OF INVENTION**

**002** The present teachings relate to rendering of 3D images. In particular, the present teachings relate to systems and methods for using z-axis values provided in a percentage format, for rendering 3D images independent of display size and viewing distance.

## **BACKGROUND OF INVENTION**

**003** A 3D image is typically rendered using z-axis information provided in the form of depth metadata associated with the image. For example, when a 3D image is captured using a stereoscopic camera, the depth metadata may be provided in the form of a grayscale difference image. The grayscale difference image does not necessarily provide absolute depth values, but does provide information in terms of differences in depth corresponding to the edges of objects contained in the image. This approach may prove useful in rendering images of a certain quality. However, it proves inadequate for more complex applications requiring 3D depth information that goes beyond stereoscopic imaging.

**004** In an alternative approach, an arbitrary rendering volume is selected for rendering an image, and certain absolute z-axis depth values are chosen for providing depth information. While this approach may prove adequate for image reproduction on a display screen of a specific size, it generally fails to accommodate multiple display screen sizes, as well as a range of viewing distances, thereby leading to some objects being located at inappropriate perceived depths within the reproduced image on certain display screens. As one example of an inappropriate perceived depth, an object may appear to be located beyond viewer infinity. When this occurs, a viewer may suffer from an undesirable divergence of the eyes. As a further example of an inappropriate perceived depth, an object

may appear to be located very close to the viewer. Such differences in perceived depth may also lead to other problems such as viewer fatigue, eyestrain, and headache.

**005** Thus, it is desirable to provide 3D depth information in a manner that accommodates the displaying of images in a variety of display screens while also accommodating a range of viewing distances.

### **BRIEF DESCRIPTION OF THE DRAWINGS**

**006** FIG. 1 shows an imaging volume that encompasses an infinity plane, a display screen plane, and a viewer location.

**007** FIG. 2 shows a graph indicating a relationship between object disparity and object distance with respect to screen.

**008** FIG. 3 shows normalized depth values for the infinity plane, the display screen plane, and the viewer location.

**009** FIG. 4 shows one example of a profile header that provides information on a target resolution for an image.

**010** FIGs. 5A and 5B provide layer and resolution information for several different profiles.

**011** FIG. 6 shows one example of a block depth map together with a reduced block depth map.

**012** FIG. 7 shows an imaging system that includes various functional blocks associated with displaying an image from the time of image capture.

**013** FIG. 8 shows one embodiment wherein 3D depth metadata is transmitted to two image receivers coupled to two different display screens having different sizes.

**014** FIG. 9 shows a flowchart depicting one embodiment of a method providing 3D depth information.

**015** FIG. 10 shows an extruded depth diagram of three objects to illustrate corrective calculations to provide desired depth perception for the three objects.

## DETAILED DESCRIPTION

**016** Throughout this description, embodiments and variations are described for the purpose of illustrating uses and implementations of the inventive concept. The illustrative description should be understood as presenting examples of the inventive concept, rather than as limiting the scope of the concept as disclosed herein. For example, it will be understood that description provided below with respect to one aspect of rendering images (for example, data transmission) may be equally pertinent to various other operations such as image reproduction, image projection, image display etc. It will also be understood that the term “image” is used herein solely for purposes of convenience. In various alternative embodiments the term “image” should be interpreted in the context of multiple images such as for example, in the context of a video stream or a collection of static images. A person of ordinary skill in the art will recognize the generality and applicability of the various concepts and methods disclosed herein to various fields and applications. Furthermore, it will be understood that the concept of generating and/or transmitting depth information as disclosed herein may be used in various other applications where other types of data are used.

**017** The 3D metadata specifically referred to herein, pertains to providing depth information in the form of percentage z-axis depth values rather than using absolute z-axis depth values. The percentage z-axis depth values may be further translated into a set of normalized z-axis depth values that are derived by assuming a virtual display screen. This process, which will be described below in more detail, permits providing of depth information (in the form of a profile), independent of the nature of the display screen (different resolutions, different screen aspect ratios, etc) or viewing distance between a human viewer and the display screen.

**018** The profile, which is transmitted in the form of 3D depth metadata along with image data, can be used by a receiver to derive depth information of various objects contained in the image. This information can be used not only for accurately reconstructing the original image, but may be also used to insert (or delete) objects such as subtitles, live graphics or captions, from the image. As can be appreciated, insertion of an object into a 2D image is a relatively straight-forward process that does not require depth information. However, inserting an object in 3D space requires an accurate assessment of depth in order to avoid undesirable results. For example, an object that is meant to be inserted behind an existing object may be incorrectly rendered in front of the existing object. Thus the inserted

object appears by occlusion to be in front of existing objects in the image whilst appearing by inter-ocular disparity to be behind the existing objects. This conflict confuses the human visual system, which then disturbs the illusion of depth that is intended to be provided in the image. In order to avoid this situation, it is desirable that the inserted object be placed in the image by taking care of the position of various objects already existing in the 3D image. Whilst this process can be carried out by a human being, using a visual inspection process, it can be appreciated that such a solution is extremely time consuming and may be neither practical nor desirable for post-production image editing or for manipulating images during broadcast of pre-recorded content (especially if the broadcast is a live broadcast).

**019** Attention is now drawn to FIG. 1, which shows an imaging volume 100 that encompasses an infinity plane 105, a display screen 110, and a viewer 115 located in front of the display screen 110. Infinity plane 105 is located at a depth wherein left/right images are separated negatively (left eye image located left of center and right eye image located right of center) by an amount that is substantially equal to an interocular separation. Interocular separation may be assumed to be approximately equal to 65 mm (average value for an adult). The plane of the display screen 110 corresponds to a location wherein a physical or a virtual screen is located. The display screen 110 is used for displaying a 3D image having objects perceptually located both in front of, and behind, the screen. A first portion located in front of the display screen 110 is referred to herein as positive volume 130 of imaging volume 100. A second portion located between display screen 110 and infinity plane 105, is referred to herein as negative real volume 125 of imaging volume 100. A third portion that is located beyond infinity plane 105 (beyond viewer infinity) is referred to herein as negative imaginary volume 120.

**020** In certain applications, imaginary volume 120 may be used for artistic reasons to “cheat” depth perception and provide a viewer a reference point for infinity when viewing an image. Specifically, in this case, it may be desirable to accentuate a separation distance for a set of objects by locating some of these objects in a “real” negative space ahead of infinity plane 105 and placing some others in an “imaginary” space behind infinity plane 105.

**021** Characterizing of imaging volume 100 into distinct portions as described above, recognizes an intrinsic relationship that exists between viewer 115 and the display device (display screen 110) for interpreting depth information, rather than using absolute values that ignore this intrinsic relationship. The simplest method for characterizing depth in a

stereoscopic display is pixel separation as viewed between a right eye and a left eye. However, the relationship between pixel separation and perceived depth is non-linear in nature and unsuitable for accurate measurement or placement of objects in 3D space.

**022** FIG. 2 shows a graph 200 displaying the non-linear relationship between object disparity and perceived object depth (represented in FIG. 2 as an object distance (%) with respect to a 7-meter wide screen having a horizontal resolution of 2048 pixels). However, one or more handicaps associated with using this non-linear relationship can be addressed by using a percentage of object distance with respect to the viewer and the viewing planes ( $z_{pv}$ ) as the value for the z-axis (depth) the perceived depth can be defined in a perceptually linear manner that is independent of display size and viewer distance.

**023** To elaborate upon this aspect, let it be assumed that display screen 110 is located at a point that is referred to herein as a 0% point ( $z_{pv}$ ). A point located midway between display screen 110 and viewer 115 is referred to herein as a +50% point ( $z_{pv}$ ), and another point located between display screen 110 and infinity plane 105 is referred to herein as a -50% point ( $z_{pv}$ ). Consequently, in a first instance, when an object contained in a 3D image is defined as having a  $z_{pv}$  value corresponding to the +50% point, the object will always be perceived as being located half-way between viewer 115 and display screen 110. On the other hand, when the object is defined as having a  $z_{pv}$  value corresponding to the 0% point, the object will be perceived as being located on the plane of the display screen 110, or in other words, twice as far from viewer 115 as in the first instance. Similarly, when the object is defined as having a  $z_{pv}$  value corresponding to the -50% point, the object will be perceived as being located behind the plane of the display screen 110, halfway between the screen plane and viewer infinity.

**024** As viewer 115 moves closer to display screen 110, the object would appear closer to viewer 115, and conversely, the object would appear to be located further away when viewer 115 moves away from display screen 110. Therefore, using the percentage z-axis approach ( $z_{pv}$ ) for viewing an object in a proportional/relative manner makes the perceived depth of the object independent of viewer distance (i.e. independent of absolute z-axis values).

**025** As pointed out above, FIG. 2 is based on a 7-meter wide screen having a horizontal resolution of 2048 pixels. However, in order to use the ( $z_{pv}$ ) value in a practical manner that

makes it independent of display size, the physical screen width ( $w_s$ ) of display screen 110 must also be taken into consideration. To do so, a combination of  $x$ ,  $y$ ,  $z_{pv}$  and  $w_s$  values may be used, wherein  $x$  is an x-axis value,  $y$  is a y-axis value,  $z_{pv}$  is the percentage object distance, and  $w_s$  is the screen size.

**026** In some cases, display screen 110 may be a virtual screen rather than a real screen. For example, when software is used for calculating various 3D parameters, it may be more convenient to use a virtual screen and normalized screen values. Under this scenario,  $z_{pv}$  may be used in the form of a normalized z-value ( $z_n$ ).

**027** Specifically, in one embodiment, a normalized screen size of 1mm per pixel width is used. Thus, a 1000 pixel wide screen is normalized to 1000mm (1m). The normalized screen size may be appropriately changed to actual size by rendering software that is executed for rendering the image on a display screen of a particular size.

**028** FIG. 3 shows normalized depth values for infinity plane 105, display screen 110, and viewer 115. On the normalized display screen 110, the separation distance between objects is substantially equal to zero, while the separation distance between objects on infinity plane 105 is presumed to be approximately equal to 65 pixels in one embodiment. When an object is located between display screen 110 and viewer 115,  $z_n$  has a positive value ( $z_n > 0$ ); when located on display screen 110  $z_n = 0$ ; when located between display screen 110 and infinity plane 105  $z_n$  has a negative value ( $z_n < 0$ ); and when located on infinity plane 105  $z_n = -100$ . Using these values, the pixel separation ( $S_p$ ) in an image can be defined by the following equations:

$$\mathbf{029} \quad S_p = z_n \left[ \frac{65}{100 - z_n} \right] \quad (\text{when } z_n > 0)$$

**030** When an object is perceived as being located at the plane of display screen 110 ( $z_n = 0$ ), the equation above reduces to  $S_p = 0$ .

**031** On the other hand, when the object is perceived as being located behind the display screen 110 towards and beyond infinity plane 105 ( $z_n < 0$ ), the equation reduces to  $S_p = 0.65z_n$ .

**032** Drawing attention to display screen 110, several coordinate values are shown in a  $x, y, z_n$  format. As can be understood,  $z_n = 0$  at this plane, and the  $x, y$  values shown at different points on display screen 110 reflect this value. Similarly,  $x, y, z_n$  values can be used to denote  $x, y$  coordinates coupled with normalized perceived depth information  $z_n$  for any number of points within the viewing volume. This combination of  $x, y, z_n$  values (where  $x$  represents screen width as a percentage,  $y$  represents screen height as a percentage, and  $z_n$  represents perceived depth as a percentage) can be transmitted from an image transmitter and used at a receiving device for rendering perceived depth in the image independent of display screen size or viewing distance. In one specific application,  $z_n$  is expressed to two decimal places, which enables about 20,000 perceptually linear depth points between viewer 115 and the infinity plane. This is suitable for a granularity of 0.5 pixels separation at infinity on a 10,000 pixel wide normalized image.

**033** Depth information, specifically 3D depth information, may be transmitted as 3D metadata together with image data, and used by a receiving device for rendering perceived depth in a reproduced image. Some aspects of this process will be described below in more detail. Specifically, FIG 10 is used below to describe display size corrective calculations based on normalized  $z$ -values ( $z_n$ ).

**034** In accordance with various embodiments in accordance with the invention, the 3D metadata may be configured in the form of a variety of profiles, one or more of which may be selected for transmission in various payloads.

**035** Furthermore, the 3D metadata may be used to provide various types of depth related information. A few examples include: a) Maximum depth, b) Minimum depth, c) Average depth, d) ROI depth, e) Depth data profile, and f) Depth map. It should be understood that this list of examples is not a comprehensive list, and also, that some of this information may be used in an optional manner, specifically by excluding such information in certain embodiments.

**036** Maximum depth is typically the  $z$ -axis value for the foremost part of an image (closest to viewer 115). The Minimum depth is typically the  $z$ -axis value for the rearmost part of an image (furthest from viewer 115). ROI depth is typically associated with a region of interest (if determined) and provides an average depth of a primary object or a portion of the image in the region of interest. The Depth data profile is a predefined or arbitrarily defined

resolution of a depth map, while the Depth map itself is a representation of the maximum depth at any given point in the image. The highest available spatial resolution for this Depth map is assumed to be equal to or greater than the original image pixel resolution.

**037** The Depth map may be further categorized as either a Primary depth map or a Secondary depth map depending upon the type of image information that is contained therein. Specifically, the Primary depth map provides image information at, or greater than, the spatial resolution of an original image. The Secondary depth map provides image information at a spatial resolution that is less than the original image.

**038** The Primary depth map defines the depth value of every point in the original image on a pixel or sub-pixel basis, and can be used for a variety of purposes such as for example, inserting one or more objects that occlude from the original image; depth correction on a regional basis (e.g. objects already contained in the original image); or overall depth correction of the original image. The Primary depth map, which may also be used for deriving one or more of the 3D metadata parameters described above, constitutes a mezzanine level from which one or more lower levels can be derived. Further details pertaining to 3D metadata and depth maps will be provided below using other figures.

**039** The Secondary depth map is typically a block-based depth map and defines the foremost object for a certain portion (greater than a whole pixel) of an original image. The data that is provided by a Secondary depth map is generally not adequate for defining the edges of individual objects in the original image. Consequently, a Secondary depth map is not necessarily used for inserting new objects that are occluded by other objects present in the original image. However, in certain cases, the Secondary depth map may be used for inserting new objects that may be placed at a desired depth in front of objects present in the original image, without leading to an occlusion violation. This process may be implemented in various broadcast or playback devices, including mobile devices, associated with delivery of commercial 3D content.

**040** The use of the Depth map, whether Primary or Secondary, permits providing different layers of depth information for satisfying a variety of usage demands. The usage demands range from a high level of complexity where pixel level information is used, to a low level where no depth map may be provided at all. In the absence of the depth map, only header information may be sent together with image data. In general, the different layers are

defined by spatial resolution (i.e. the number of points representing the entire image). In one embodiment, each layer is typically configured to provide half as much image resolution as an adjacent higher layer, moving down from the original image resolution. For example, in broadcast and feature film applications, image resolutions may be based on formats such as High Definition (HD), 2K Cinema, or 4K Cinema. Accordingly, a suitable profile header is provided that may be used for determining absolute resolution values from a depth map. In this particular case, the profile header is defined as including a Layer designator, a Set designator and a Subset designator. FIG. 4 shows one example of a profile header that provides information on a target resolution for an image, in accordance with Layer 12, Cinema and Full Container.

**041** FIGs. 5A and 5B provide layer and resolution information for several different profiles. Information for creating several profile headers (similar to the example header shown in FIG. 4) can be derived from the columns under the label “Profile.”

**042** Attention is now drawn to FIG. 6, which shows one example of a block depth map 600 together with a reduced block depth map 650. Block depth map 600 is a Secondary depth map in an “ $m \times n$ ” row-column format (in this example,  $7 \times 14$ ) from which reduced block depth map 650 having a “ $p \times q$ ” row-column format (in this example,  $2 \times 4$ ) can be derived using a cross-conversion process. The cross-conversion process may be used when the resolution values provided by block depth map 600 are not directly compatible to a particular application. As can be understood, it is desirable that the cross-conversion process preserves important information. In one embodiment, this is implemented by using multiple partitions and ensuring that the foremost values within each partition is used, even when these foremost values traverse the boundary of a partition.

**043** To elaborate, the foremost value located in partition 605 is 4. This value (4) is cross-converted to block 606 in reduced block depth map 650. On the other hand, the foremost value (4) in partition 610 is located on the boundary between partitions 605 and 610. This value (4) is cross-converted to block 607 in reduced block depth map 650. Furthermore, the foremost value (2) in partition 615 is located on the boundary between partitions 615 and 635. This value (2) is cross-converted to block 608 in reduced block depth map 650. Similarly, the foremost value (1) in partition 625 is located on the boundary between partitions 625 and 605. This value (1) is cross-converted to block 611 in reduced

block depth map 650. The foremost values in each of the other blocks 620, 630, 635 and 640 are cross-converted to corresponding blocks 609, 612, 613 and 614 respectively.

**044** The rationale behind using the foremost values in the cross-conversion is based on two factors. The first factor is to ensure that the possibility of an occlusion violation is minimized or eliminated. The second factor is to ensure that at least the foremost depth value in each partition is accurate even if the rest of the partition has significantly lower depth values.

**045** In the case wherein an object is to be inserted in a manner that intentionally causes an occlusion with reference to pre-existing objects, block depth map 600 may be avoided and a Primary depth map may be used instead, so as to ensure pixel-level occlusion accuracy. If an object (such as a broadcaster's logo, a caption, or a sub-title), is inserted into a 3D image without paying attention to the depths of various objects in the 3D image, there is a possibility that the inserted object may be erroneously rendered in front of an object, while simultaneously appearing to be located behind the object in terms of depth perception. As understood by a person of ordinary skill in the art, such a rendering violates depth cues in the Human Visual System (HVS), wherein if an object is hidden by another object, the hidden object must be spatially located behind the other object rather than in the front.

**046** Furthermore, an undesirable breakdown in 3D visualization may take place when an object is inserted at a significantly different depth with reference to other objects located further behind the inserted object. This situation may be further compounded when multiple objects are inserted into an existing 3D image. In this case, the placement of the multiple objects has to be carried out not only with respect to existing objects in the image but also with respect to each other, so as to avoid occlusion violation between the inserted objects and existing objects, as well as occlusion violation between the inserted objects themselves.

**047** There are several other 3D depth related operations that can be carried out upon an image in addition to the insertion of objects described above. In a first example application, a depth correction may be carried out upon an image in order to address issues such as for example, parallax errors and geometric defects. The depth correction may include techniques such as a parallax shifting, geometric correction, and/or complex image segmentation with edge warping. Whilst these techniques are not described in detail herein, it will be understood that parameters such as Maximum Depth (foremost) and Minimum Depth (rearmost) depth

points may be used. More complex depth correction can be achieved by analysis of the overall depth distribution across the entire total depth of the image, and the use of ROI Depth and Average Depth may be applicable in this case.

**048** In a second example application of a 3D depth related operation, one or more composite objects may be inserted into an image, with appropriate depth and occlusion.

**049** In a third example application of a 3D depth related operation, a depth change operation and/or a depth normalization action may be carried out. The depth of a stereoscopic scene as perceived by a viewer varies when seen on different display devices. This perception is based on several factors such as screen size, pixel pitch and viewer distance from the display. A stereoscopic image created for a cinema screen may display a significantly lesser depth effect upon displaying of the image on a television screen, and even further reduction of depth effect when viewed on a screen of a mobile device. Similarly, a stereoscopic image that is optimized for 3D viewing on a mobile device may not provide adequate depth perception on a television screen, and may be unacceptable for viewing on a cinema screen as a result of extreme separation of objects in objects viewed by the left eye and right eye of the viewer. Such issues may be resolved by using the depth related solutions disclosed herein, in either an automatic manner or manually. The manual operation for controlling depth perception may be comparable to using a volume control for controlling the amplitude of sound.

**050** Certain depth related issues may be addressed by normalizing image parameters using the depth metadata disclosed herein. Depth can be normalized in several different ways. In a first approach, the depth metadata is used to modify the image using a screen size and pixel width.

**051** Several other depth related operations may be carried out upon an image, such as for example, sliding the left and right eye images with respect to each other; geometrically distorting the image; warping and/or segmentation and synthesis of the image.

**052** Attention is now drawn to FIG. 7, which shows an imaging system 700 that includes various functional blocks associated with transmitting of a combination of image data and 3D metadata, and using the combination at a receiving device for displaying a 3D image with appropriate perceived depth.

**053** The block labeled imaging system 705 represents one or more devices, such as for example, an image capture system (a stereoscopic camera, a 3D camera, etc); a metadata generator for generating metadata that can be transmitted together with image data so as to provide perceived depth information to a distant receiver; and a transmitter unit for transmitting the image data and 3D metadata to the distant receiver.

**054** In one embodiment, imaging system 705 transmits a profile header (such as the profile header shown in FIG. 4) together with a depth map (for example, one of the Primary or the Secondary depth map as described above), and 3D depth metadata.

**055** The 3D depth metadata provides depth information in the form of z-axis values pertaining to maximum depth, minimum depth, and average depth of an image. The z-axis values may be provided in normalized form as  $z_n$  values. The 3D metadata may further include a depth data profile and optionally, a region of interest (ROI) depth.

**056** In another embodiment, imaging system 705 transmits only a profile header, which provides resolution information but does not include a depth map or 3D metadata.

**057** Transmission media 710 represents a variety of communication media and networks (including the Internet) such as for example, wired media, wireless media, optical media etc that use a variety of physical entities associated with a signal transmission system, in a wide variety of signaling formats. Details of transmission media 705 is generally known to persons of ordinary skill in the art and will not be elaborated upon herein, in order to retain focus upon the main aspects of the invention.

**058** Metadata extractor 715, which may be a part of a receiver unit, is used to derive 3D depth information from the signal transmitted by imaging system 705. Some non-limiting examples of receivers include Blu-ray video players, set-top boxes, software encoders, movie projectors, television sets, DVD players and video game machines. Additional applications include BD video encoders, players, and videodiscs created in the appropriate format, or content and systems targeted for applications such as broadcast, satellite, and IPTV systems.

**059** Renderer 720 uses the 3D information provided by metadata extractor 715 and renders an image in accordance with the nature of the display system 725. For example, if the received profile header indicates a cinema full container format, renderer 720 may utilize the 3D depth metadata to modify the depth data contained in the image in order to display the

image on display system 725, which may be a display on a handheld device such as a cellular phone or a personal digital assistant (PDA).

**060** This aspect may be described further using FIG. 8, which shows image transmitter 805 transmitting image data to a first image receiver 810 and to a second image receiver 815. Image transmitter 805 may include an image capture system 806 and a 3D metadata extractor 807.

**061** Either, or both, of the two image receivers may be a part of at least one of a communications device, a computer system, a video system, an audio-video system, an image capture device, an image display device, an image projection device, or an image transmission system.

**062** In one embodiment, image transmitter 805 transmits a single profile to both image receivers. The single profile includes a first profile header (corresponding to a cinema, full-container as shown in FIG. 4), a first depth map, and a first 3D depth metadata.

**063** Image receiver 810 is coupled to a cinema screen 820 that displays images in the format defined by the first profile header. Accordingly, renderer 811 uses the first depth map without modification of the depth data therein for displaying images on cinema screen 820. On the other hand, image receiver 815 is coupled to a screen 825 on a telephone. Screen 825 cannot display images in the format defined by the first profile header. Accordingly, renderer 816 uses the first depth map to derive a reduced block depth map (such as the one shown in FIG. 6) in order to enable viewing of images on screen 825.

**064** In another embodiment, image transmitter 805 transmits the first profile to image receiver 810 and a different profile to image receiver 815. Each of receivers 810 and 815 use their respective profiles that are expressly tailored for displays 820 and 825 respectively. The normalized z-axis values are used in each case to render the correct depth values in the images displayed on displays 820 and 825 respectively.

**065** In yet another embodiment, image transmitter 805 transmits multiple profiles to each of image receiver 810 and image receiver 815. Image receiver 810 selectively uses a first profile in the multiple profiles, while image receiver 815 selectively uses a different profile selected from amongst the multiple profiles. The multiple profiles may be transmitted

in a variety of ways, for example, in a sequential arrangement, a parallel arrangement, or a multiplexed arrangement.

**066** Attention is now drawn to FIG. 9, which shows a flowchart 900 depicting one embodiment of a method providing 3D depth information. It is to be understood that any method steps or blocks shown in FIG. 9 represent modules, segments, or portions of code that include one or more executable instructions for implementing specific logical functions or steps in the method. In certain implementations, one or more of the steps may be performed manually. It will be appreciated that, although particular example method steps are described below, additional steps or alternative steps may be utilized in various implementations without detracting from the spirit of the invention. Moreover, steps may be executed out of order from that shown or discussed, including substantially concurrently or in reverse order, depending on various alternative implementations. Code may be also contained in one or more devices, and may not be necessarily confined to any particular type of device. The explanation below, while possibly implying code residency and functionality in certain devices, does so solely for the purposes of explaining concepts behind the invention, and should not be construed in a limiting manner.

**067** In step 905, a first parameter is defined based on a percentage of a width of an image. In step 910, a second parameter is defined based on a percentage of a height of the image. In step 915, a third parameter is defined based on a percentage of an object distance from a viewer. Each of these parameters has been described above using FIGs 2 and 3, for example. In step 920, the first, second and third parameters are combined to provide 3D depth information of the image.

**068** The combination of the three parameters, for example of  $x$ ,  $y$ ,  $z_n$  values (where  $x$  represents screen width as a percentage,  $y$  represents screen height as a percentage, and  $z_n$  represents perceived depth as a percentage) can be transmitted from an image transmitter (such as imaging system 705 described above) and used at a receiving device (such as renderer 720 and display system 725 described above using FIG. 7) for reconstructing perceived depth in the image independent of display screen size or viewing distance.

**069** Elaborating upon the aspect of image rendering in terms of reconstructing perceived depth, it is generally understood that screen size does play a significant role. Consequently, an approximate set of rules may be followed in order to accommodate various

screen sizes. The description below provides one example of how device correction can be carried out in a receiving device so as to adjust “infinity” and provide a desired depth perception.

**070** In this example, the image is reproduced on a display screen that is approximately 30 inches (76.8cm) wide, 1920 pixel resolution, and 0.4mm pixel pitch. The infinity point provides a negative separation of 65mm with a separation of 162.5 pixels. The normalized display has a pixel pitch of 1mm, thereby causing a reduction in left-right image pixel separation by 0.4. The image is corrected with a pixel shift of 48.75 pixels towards center for normalizing the image.

**071** Convergence point for depth is set as follows:

- a) Very large screen (Cinema / I-Max) = all depth in front (i.e. infinity is on the screen plane, maximum positive depth (in front of screen) = 60% of viewer distance)
- b) Large screen (Cinema) = more in front than behind (about 2/3 total depth in front, 1/3 total depth behind).
- c) Small Screen (TV) = more behind than in front (about 1/3 total depth in front, 2/3 total depth behind).
- d) Very small screen (mobile) = Infinity as far behind as possible, no positive depth (in front of screen)

**072** Assuming that the original image was mastered with infinity point  $z_{ni} = -100$  left right image shift where  $z_{ci}$  is the corrected depth position for infinity, and maximum positive depth is  $z_n = -40$ . So the total depth in the scene is  $z_n = 60$ .

**073** For the above conditions, the following rules may be applied:

- a)  $z_{ci} = z_{ni} + 100$  Infinity on screen plane, maximum object excursion out of screen 60% of viewer distance
- b)  $z_{ci} = z_{ni} + 80$  Infinity 20% behind screen plane, maximum object excursion out of screen 40% of viewer distance
- c)  $z_{ci} = z_{ni} + 60$  Infinity 40% behind screen plane, maximum object excursion out of screen 20% of viewer distance
- d)  $z_{ci} = z_{ni} + 40$  Infinity 60% behind screen plane, no object excursion out of screen

074 Device correcting the image could use a “Z-Norm” value in metadata, a flag to alert the receiving device that the received image may be corrected using the associated metadata to provide a desired shift for various size displays. Any display sizes falling between those described in the metadata could either interpolate an intermediate value or simply chose the closest value.

075 In one embodiment, over-scanned left and right eye images are sent in their entirety so as to allow corrections to be carried for two extreme display screen sizes (smallest and largest display screens).

076 FIG. 10 shows an extruded depth diagram of three objects to illustrate corrective calculations that may be carried out to provide desired depth perception. The three objects 955, 960 and 965 extrude from infinity plane 950. Object 955 is shown as protruding to a – 50% z-norm position, object 960 to a 0 z-norm position, and object 965 to a 30% z-norm position. The absolute separation between the three objects is suitably adjusted in order to achieve these depths on different size displays. In this example, the three displays are a cinema screen, a television screen, and a screen of a mobile device (such as a portable media player or a cellphone). The attributed of these three devices are provided in Table 1 below.

Table 1 – Display attributes

Screen Type	Width (mm)	X Resolution (pixels)	Pixel Pitch (mm)
Cinema	7000	1920	3.6458
TV	1000	1920	0.5208
Mobile device	75	960	0.0781

077 In order to display the three objects at a perceptual depth of Z-norm -50, 0 and +30, Table 2 shows pixel separation between the left eye and right eye images.

Table 2 - Pixel separation

Object	Applied Zn to Image, %	Px separation on Cinema screen	Px separation on TV screen	Px separation on Mobile screen
Square (965)	30	7.6	53.5	356.6
Triangle (960)	0	0.0	0.0	0.0
Circle (955)	-50	-8.9	-62.4	-416.0

078 As can be seen from Table 2, the pixel separation for the cinema screen (large screen) is significantly less than that for the screen of the mobile device. Provided below is one example calculation to explain the values shown in Table 2. Object 965 (square) has  $z_n =$

30%. This value is plugged into the afore-mentioned equation for  $S_p$  i.e.  $S_p = z_n \left[ \frac{65}{100 - z_n} \right]$

(when  $z_n > 0$ )

$$079 \quad S_p = 30 \left[ \frac{65}{100 - 30} \right] = 27.85 \text{mm.}$$

080 Table 1 indicates that the pixel pitch for a cinema screen is 3.6458. Therefore, based on this pixel pitch and the  $S_p$  value of 27.85mm, the pixel separation for object 965 on a cinema screen is derived as  $27.85/3.6458 = 7.6$  (column 3 of Table 1, corresponding to the cinema screen).

081 Similarly, for object 955 (circle) where  $z_n = -50\%$ , the  $S_p$  value is  $-50(0.65) = -32.5$ , and the pixel separation is  $-32.5/3.6458 = -8.9$  for displaying object 955 on a cinema screen (column 3 of Table 1, corresponding to the cinema screen).

082 The methods and systems described herein may be implemented in hardware, software, firmware or combination thereof. Features described as steps, blocks, modules or components may be implemented together (e.g., in a logic device such as an integrated logic device) or separately (e.g., as separate connected logic devices). The software portion of the methods of the present disclosure may comprise a computer-readable storage medium in which is stored instructions that, when executed by a computer system, execute all or parts of the described methods. The computer-readable storage medium may comprise, for example, a random access memory (RAM) and/or a read-only memory (ROM). At least a portion of the instructions may be executed by a processor (e.g., a microprocessor, a microcontroller, a digital signal processor (DSP), or implemented as a hardware circuit in an application specific integrated circuit (ASIC), a standard logic integrated circuit, or a field programmable logic array (PLD, FPGA etc.)).

083 All patents and publications mentioned in the specification may be indicative of the levels of skill of those skilled in the art to which the disclosure pertains. All references cited in this disclosure are incorporated by reference to the same extent as if each reference had been incorporated by reference in its entirety individually.

084 It is to be understood that the disclosure is not limited to particular methods or systems, which can, of course, vary. It is also to be understood that the terminology used

herein is for the purpose of describing particular embodiments only, and is not intended to be limiting. As used in this specification and the appended claims, the singular forms "a," "an," and "the" include plural referents unless the content clearly dictates otherwise. The term "plurality" includes two or more referents unless the content clearly dictates otherwise. Unless defined otherwise, all technical and scientific terms used herein have the same meaning as commonly understood by one of ordinary skill in the art to which the disclosure pertains.

**085** The examples set forth above are provided to give those of ordinary skill in the art a complete disclosure and description of how to make and use the embodiments of the enhancement methods for sampled and multiplexed image and video data of the disclosure, and are not intended to limit the scope of what the inventors regard as their disclosure. Modifications of the above-described modes for carrying out the disclosure may be used by persons of skill in the video art, and are intended to be within the scope of the following claims.

**086** A number of embodiments of the disclosure have been described. Nevertheless, it will be understood that various modifications may be made without departing from the spirit and scope of the present disclosure. Accordingly, other embodiments are within the scope of the following claims.

## CLAIMS

1. A method of rendering 3D images, comprising:
  - receiving a profile comprising a profile header, a depth map, and 3D depth metadata; and
  - using the depth map to derive depth data that is independent of display screen size and viewing distance.
2. The method of claim 1, wherein the depth data comprises normalized z-axis values defining the relative position of an imaged object with respect to a human viewer.
3. The method of claim 1, wherein the 3D depth metadata comprises:
  - maximum depth data comprising a first normalized z-axis value derived from a foremost part of the image;
  - minimum depth data comprising a second normalized z-axis value derived from a rearmost part of the image; and
  - average depth data comprising an average normalized z-axis value derived from substantially all parts of the image.
4. The method of claim 3, wherein the 3D depth metadata further comprises:
  - a region of interest depth data that indicates an average depth in at least one of a) a primary object in the image or b) a portion of interest in the image.
5. The method of claim 1, wherein the profile header comprises a layer identifier, a set identifier, and a subset identifier, and provides target resolution information for which the profile was created.
6. The method of claim 1, wherein the depth map is represented as one of a primary depth map or a secondary depth map, wherein the primary depth map provides depth values of an image at a pixel level or a sub-pixel level; and the secondary depth map is a block depth map that provides depth values at a greater-than-a-pixel level.
7. The method of claim 6, further comprising:
  - analyzing the primary depth map for extracting the 3D depth metadata.
8. The method of claim 6, further comprising:
  - providing the depth map in the form of a first block depth map having  $m$  rows and

$n$  columns.

9. The method of claim 8, further comprising:
  - converting the first block depth map having  $m$  rows and  $n$  columns into a reduced block depth map having  $p$  rows and  $q$  columns wherein  $m > p$  and  $n > q$ .
10. The method of claim 9, wherein the converting comprises:
  - partitioning the first block depth map having  $m$  rows and  $n$  columns into  $p \times q$  partitions, wherein each partition comprises a plurality of depth values; and
  - using the foremost depth values contained in each of the  $p \times q$  partitions to identify corresponding depth values in the reduced block depth map having  $p$  rows and  $q$  columns.
11. The method of claim 9, further comprising:
  - using at least one of the first block depth map or the reduced block depth map to avoid occlusion violation when inserting a new object into the image.
12. The method of claim 1 further comprising:
  - using the 3D depth metadata contained in the profile to avoid occlusion violation when inserting a new object into the image.
13. The method of claim 12, wherein the new object is at least one of a caption, a subtitle, or a graphic.
14. The method of claim 1, wherein the depth data provided by the depth map includes a first parameter based on a percentage of a width of the image; a second parameter based on a percentage of a height of the image; and a third parameter based on a percentage of an object distance with respect to at least one of a screen or a human viewer.
15. A computer-readable storage medium having stored thereon computer-executable instructions for executing a method in accordance with any of claims 1-3, 5, 6 or 14.
16. An imaging system comprising:
  - a display screen; and
  - a renderer configured to receive a profile comprising a profile header, a depth map, and 3D depth metadata, and further configured to use the profile to derive depth data that is independent of viewing distance and display screen size.

17. The system of claim 16, wherein the 3D depth metadata comprises:
  - maximum depth data comprising a first normalized z-axis value derived from a foremost part of an image;
  - minimum depth data comprising a second normalized z-axis value derived from a rearmost part of the image; and
  - average depth data comprising an average normalized z-axis value derived from substantially all parts of the image.
18. The system of claim 16, wherein the display screen is at least one of a movie screen, a television screen, or a display screen of a handheld device.
19. The system of claim 16, wherein the depth data is derived on the basis of a limitation of the display screen.
20. The system of claim 16, further comprising:
  - a 3D image capture system for capturing an image; and
  - a metadata extractor for extracting the 3D depth metadata from the captured image.
21. The system of claim 20, further comprising a receiver unit for receiving the image.
22. The system of claim 21, wherein the receiver is part of at least one of a communications device, a computer system, a video system, an audio-video system, an image capture device, an image display device, an image projection device, or an image transmission system.
23. The system of claim 20, wherein the image is part of a stream of video images.
24. The system of claim 23, wherein the stream of video images is at least one of a real-time video stream or a time-shifted video stream.
25. A method of providing 3D depth information of an object contained in an image, the method comprising:
  - defining a first parameter based on a percentage of a width of the image;
  - defining a second parameter based on a percentage of a height of the image;
  - defining a third parameter based on a percentage of a position of the object relative to a human viewer; and
  - combining the first, second and third parameters to provide 3D depth metadata of

the image.

26. The method of claim 25, further comprising:
  - defining the third data parameter as normalized  $z$ -axis values based on a plurality of depth points.
27. The method of claim 26, wherein the plurality of depth points is based at least in part on a location where a human viewer is located, a display screen plane, and an infinity plane.
28. The method of claim 27, wherein a first normalized  $z$ -axis value is defined as substantially equal to zero when an object is perceived as to be located on the display screen plane; and a second normalized  $z$ -axis value is defined as approximately equal to 65 pixels of a normalized display when the object is perceived to be located on the infinity plane.
29. The method of claim 27, wherein a normalized  $z$ -axis value is positive when an object is perceived to be located between the display screen plane and the human viewer; and negative when the object is perceived to be located between the infinity plane and the display screen plane.
30. The method of claim 25, further comprising:
  - using the 3D depth metadata to derive depth data that is independent of viewing distance and display screen size.

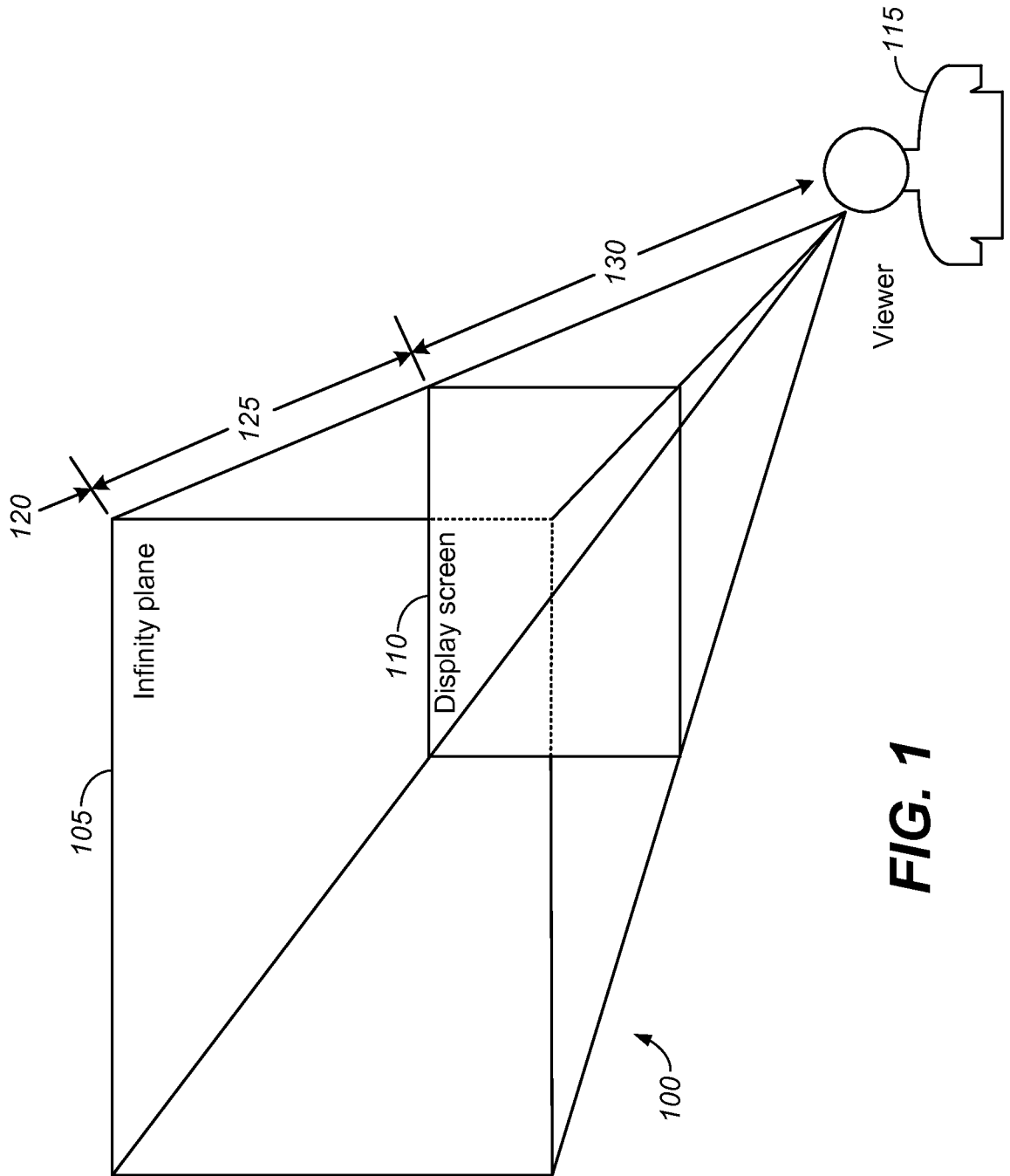

**FIG. 1**

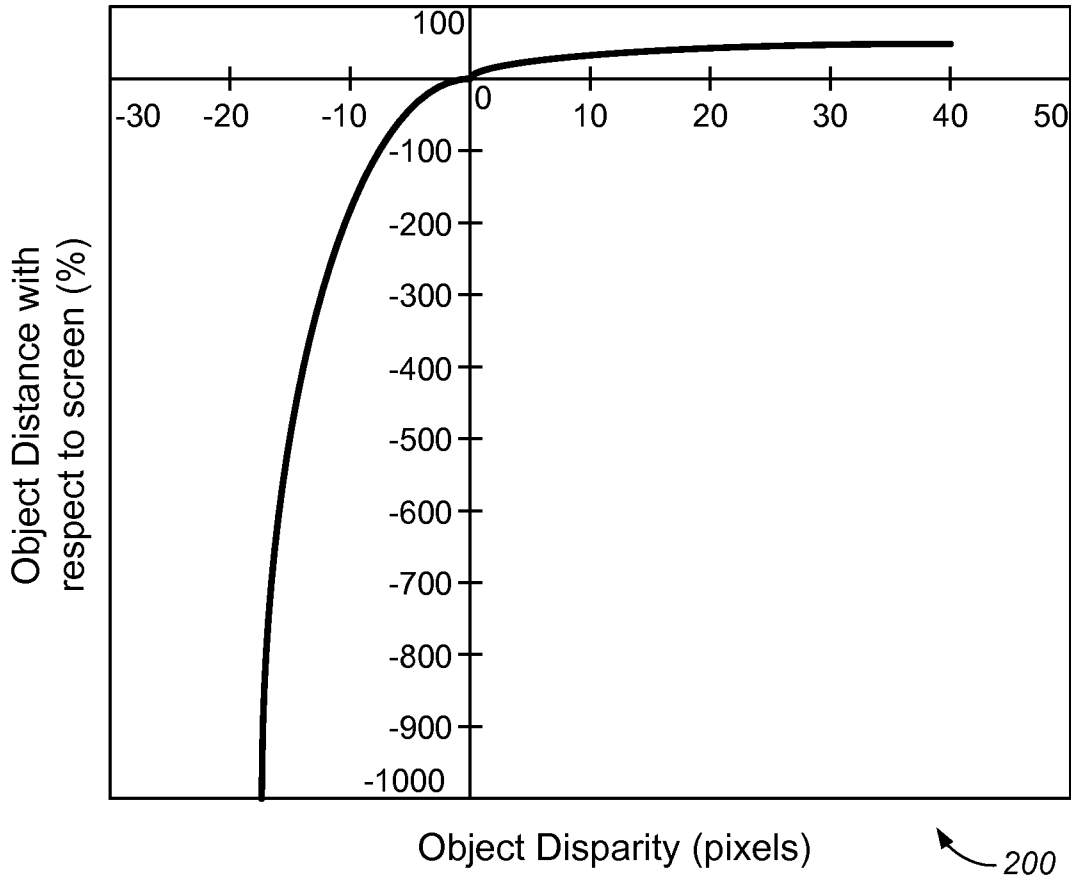

**FIG. 2**

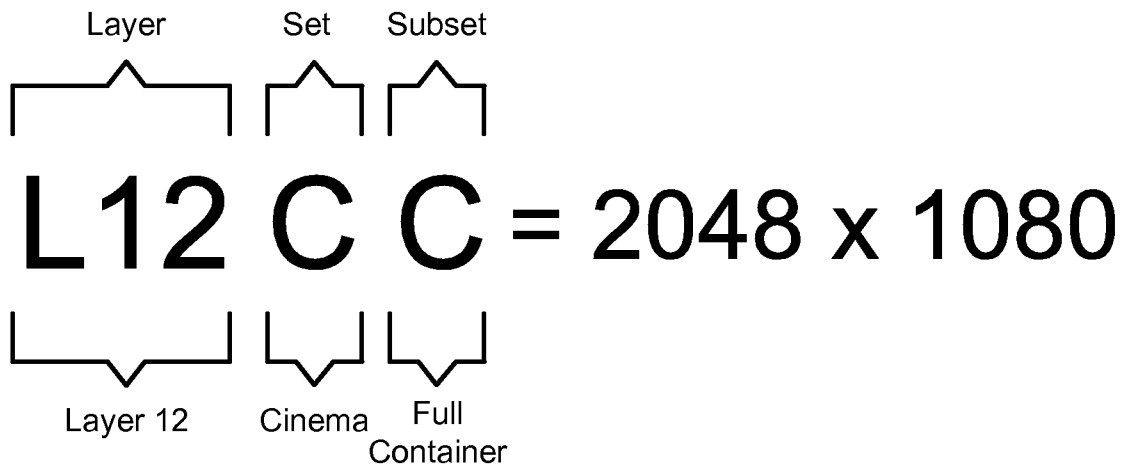

**FIG. 4**

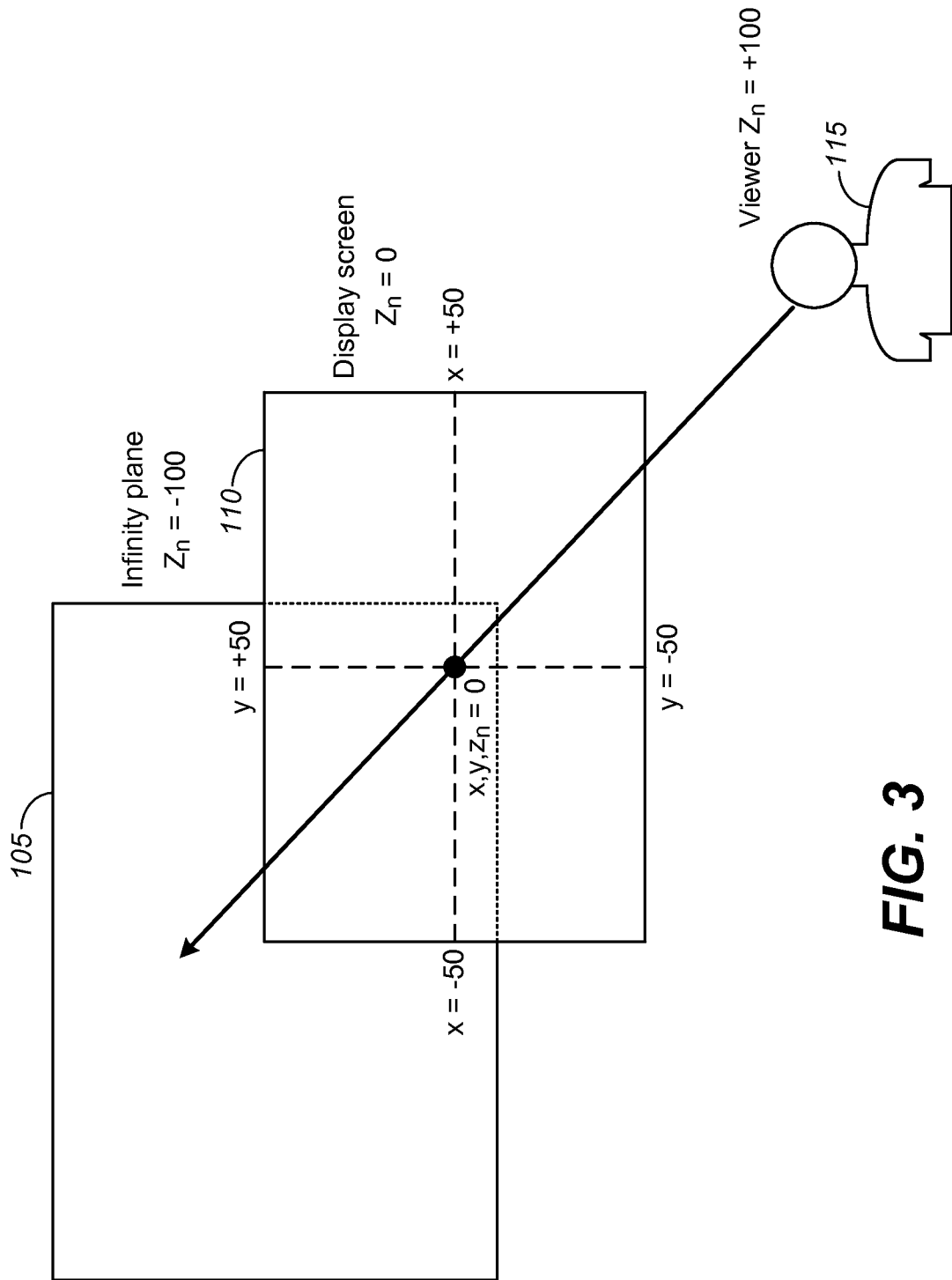

**FIG. 3**

LAYER	SET	SUBSET	RESOLUTION H	RESOLUTION V	PROFILE			
	<b>Cinema</b>	<b>Full Container</b>						
14	C	C	8192	4320	L	14	C	C
13	C	C	4096	2160	L	13	C	C
12	C	C	2048	1080	L	12	C	C
11	C	C	1024	540	L	11	C	C
10	C	C	512	270	L	10	C	C
9	C	C	256	135	L	9	C	C
8	C	C	128	68	L	8	C	C
7	C	C	64	34	L	7	C	C
6	C	C	32	17	L	6	C	C
5	C	C	16	8	L	5	C	C
4	C	C	8	4	L	4	C	C
3	C	C	4	2	L	3	C	C
2	C	C	2	1	L	2	C	C
1	C	C	1	1	L	1	C	C
0	C	C	0	0	L	0	C	C
	<b>Cinema</b>	<b>1.85:1 Flat</b>						
14	C	F	7992	4320	L	14	C	F
13	C	F	3996	2160	L	13	C	F
12	C	F	1998	1080	L	12	C	F
11	C	F	999	540	L	11	C	F
10	C	F	500	270	L	10	C	F
9	C	F	250	135	L	9	C	F
8	C	F	125	68	L	8	C	F
7	C	F	62	34	L	7	C	F
6	C	F	31	17	L	6	C	F
5	C	F	16	8	L	5	C	F
4	C	F	8	4	L	4	C	F
3	C	F	4	2	L	3	C	F
2	C	F	2	1	L	2	C	F
1	C	F	1	1	L	1	C	F
0	C	F	0	0	L	0	C	F

**FIG. 5A**

	Cinema	2.39:1 Scope							
14	C	S	8192	3428		L	14	C	S
13	C	S	4096	1714		L	13	C	S
12	C	S	2048	858		L	12	C	S
11	C	S	1024	429		L	11	C	S
10	C	S	512	215		L	10	C	S
9	C	S	256	107		L	9	C	S
8	C	S	128	54		L	8	C	S
7	C	S	64	27		L	7	C	S
6	C	S	32	13		L	6	C	S
5	C	S	16	7		L	5	C	S
4	C	S	8	3		L	4	C	S
3	C	S	4	2		L	3	C	S
2	C	S	2	1		L	2	C	S
1	C	S	1	1		L	1	C	S
0	C	S	0	0		L	0	C	S
	Broadcast	HD1080							
12	B	H	1920	1080		L	12	B	H
11	B	H	960	540		L	11	B	H
10	B	H	480	270		L	10	B	H
9	B	H	240	135		L	9	B	H
8	B	H	120	68		L	8	B	H
7	B	H	60	34		L	7	B	H
6	B	H	30	17		L	6	B	H
5	B	H	15	8		L	5	B	H
4	B	H	8	4		L	4	B	H
3	B	H	4	2		L	3	B	H
2	B	H	2	1		L	2	B	H
1	B	H	1	1		L	1	B	H
0	B	H	0	0		L	0	B	H
	Broadcast	HD720							
12	B	W	1280	720		L	12	B	W
11	B	W	640	360		L	11	B	W
10	B	W	320	180		L	10	B	W
9	B	W	160	90		L	9	B	W
8	B	W	80	45		L	8	B	W
7	B	W	40	23		L	7	B	W
6	B	W	20	11		L	6	B	W
5	B	W	10	6		L	5	B	W
4	B	W	5	3		L	4	B	W
3	B	W	3	1		L	3	B	W
2	B	W	1	1		L	2	B	W
1	B	W	1	1		L	1	B	W

**FIG. 5B**

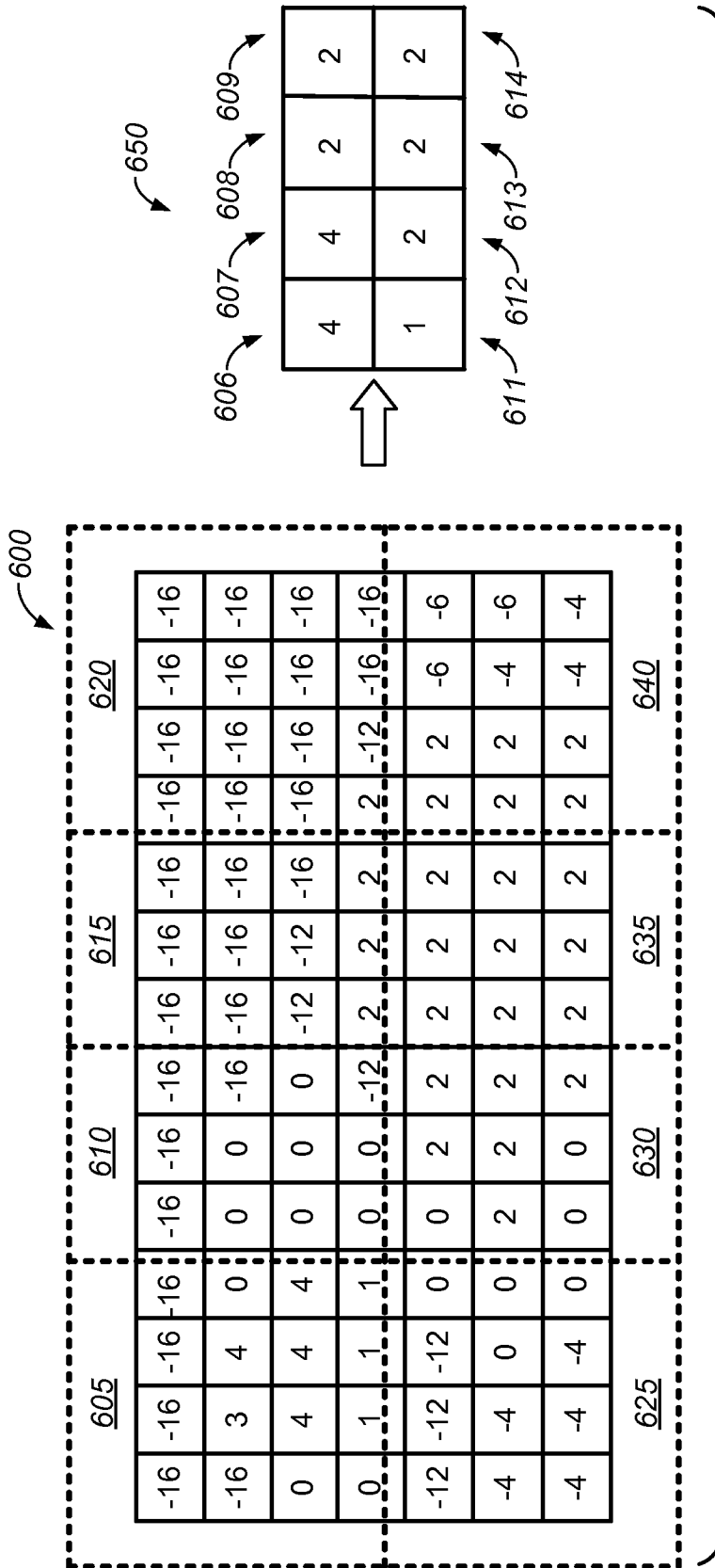

**FIG. 6**

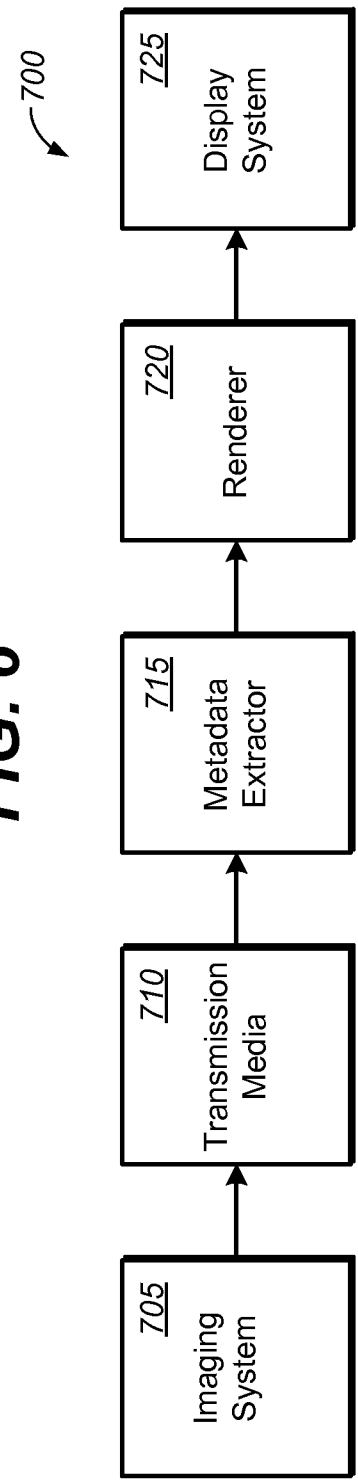

**FIG. 7**

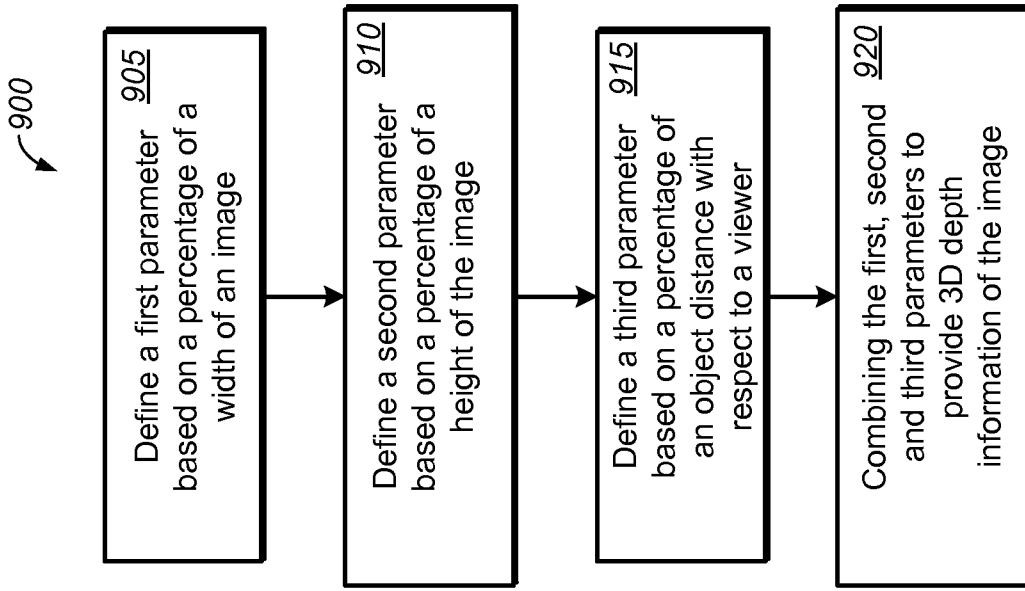

**FIG. 9**

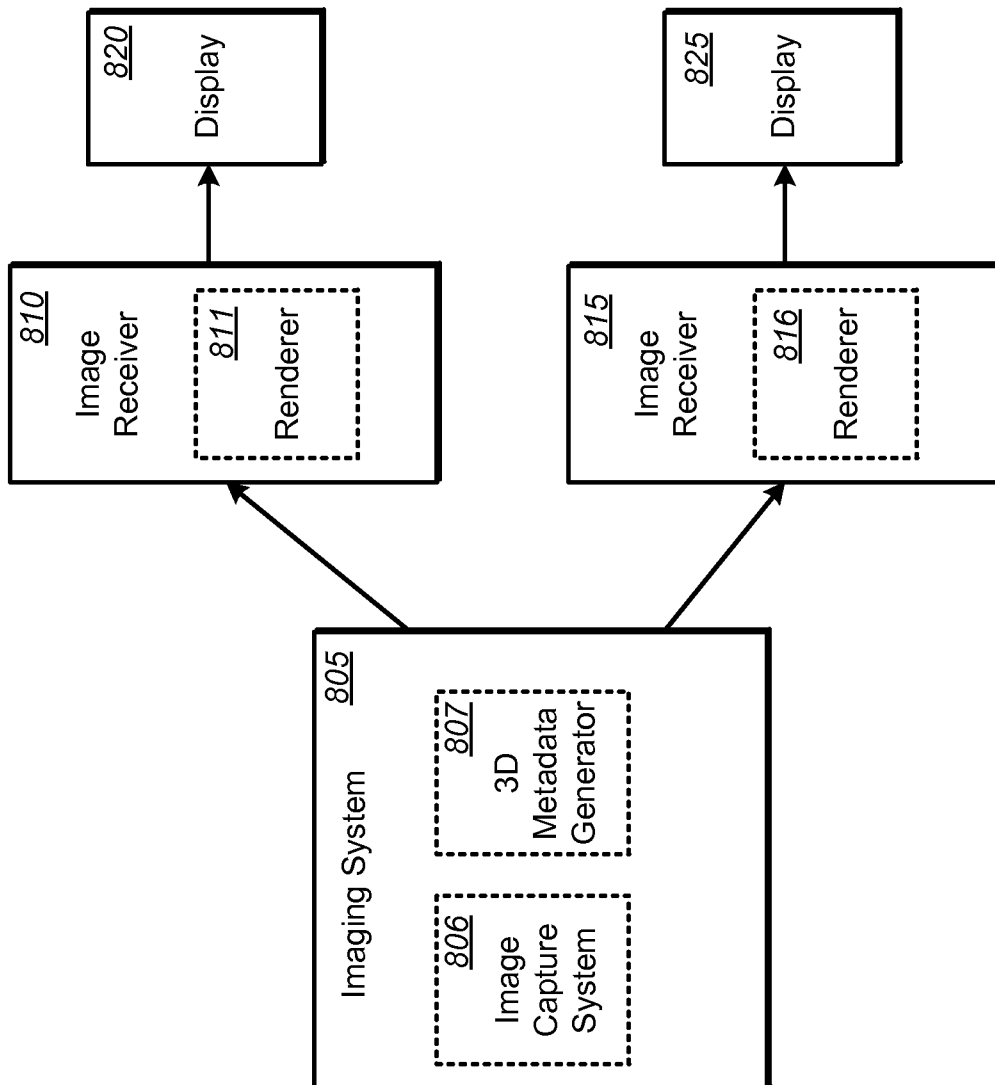

**FIG. 8**

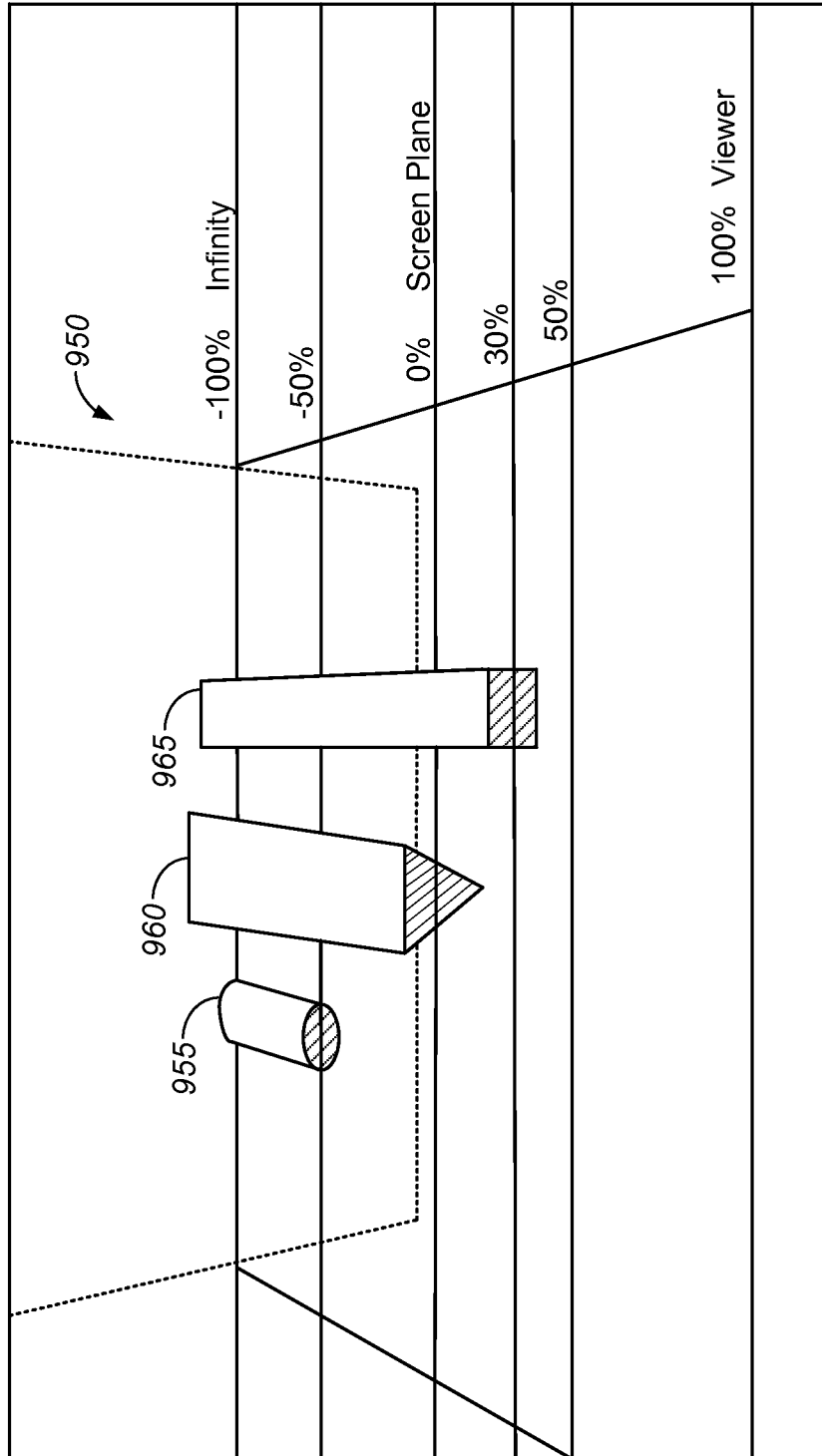

**FIG. 10**

INTERNATIONAL SEARCH REPORT

International application No  
PCT/US2012/032857

A. CLASSIFICATION OF SUBJECT MATTER  
INV. H04N13/00  
ADD.  
  
According to International Patent Classification (IPC) or to both national classification and IPC

B. FIELDS SEARCHED  
Minimum documentation searched (classification system followed by classification symbols)  
G06T H04N

Documentation searched other than minimum documentation to the extent that such documents are included in the fields searched

Electronic data base consulted during the international search (name of data base and, where practicable, search terms used)  
EPO-Internal, WPI Data

C. DOCUMENTS CONSIDERED TO BE RELEVANT

Category*	Citation of document, with indication, where appropriate, of the relevant passages	Relevant to claim No.
X	US 2011/032328 A1 (RAVEENDRAN VIJAYALAKSHMI R [US] ET AL) 10 February 2011 (2011-02-10)	1,16
Y	abstract paragraphs [0010], [0028], [0031], [0102], [0171] paragraphs [0153], [0170] figure 7	2-4,6,7, 11-15, 17-27, 29,30
Y	----- WO 2011/013030 A1 (KONINKL PHILIPS ELECTRONICS NV [NL]; NEWTON PHILIP STEVEN [NL]; BOLIO) 3 February 2011 (2011-02-03)  abstract page 3, line 8 - page 4, line 24 page 6, line 21 - line 32 claims 1,2,9,16-18  ----- -/--	2-4,6,7, 11-15, 17-27, 29,30

Further documents are listed in the continuation of Box C.

See patent family annex.

\* Special categories of cited documents :

"A" document defining the general state of the art which is not considered to be of particular relevance

"E" earlier application or patent but published on or after the international filing date

"L" document which may throw doubts on priority claim(s) or which is cited to establish the publication date of another citation or other special reason (as specified)

"O" document referring to an oral disclosure, use, exhibition or other means

"P" document published prior to the international filing date but later than the priority date claimed

"T" later document published after the international filing date or priority date and not in conflict with the application but cited to understand the principle or theory underlying the invention

"X" document of particular relevance; the claimed invention cannot be considered novel or cannot be considered to involve an inventive step when the document is taken alone

"Y" document of particular relevance; the claimed invention cannot be considered to involve an inventive step when the document is combined with one or more other such documents, such combination being obvious to a person skilled in the art

"&" document member of the same patent family

Date of the actual completion of the international search  2 July 2012	Date of mailing of the international search report  09/07/2012
--	--

Name and mailing address of the ISA/ European Patent Office, P.B. 5818 Patentlaan 2 NL - 2280 HV Rijswijk Tel. (+31-70) 340-2040, Fax: (+31-70) 340-3016	Authorized officer  Lauri, Lauro
--	--

## INTERNATIONAL SEARCH REPORT

International application No  
PCT/US2012/032857

C(Continuation). DOCUMENTS CONSIDERED TO BE RELEVANT		
Category*	Citation of document, with indication, where appropriate, of the relevant passages	Relevant to claim No.
A	WO 2010/021666 A1 (THOMSON LICENSING [FR]; TIAN DONG [US]; PANDIT PURVIN BIBHAS [US]; YIN) 25 February 2010 (2010-02-25) the whole document	1-30
A	----- EP 2 202 992 A2 (SAMSUNG ELECTRONICS CO LTD [KR]) 30 June 2010 (2010-06-30) the whole document	1-30
A	----- US 2002/015103 A1 (SHI ZHIMIN [US]) 7 February 2002 (2002-02-07) the whole document	1-30
	-----	

# INTERNATIONAL SEARCH REPORT

Information on patent family members

International application No

PCT/US2012/032857

Patent document cited in search report	Publication date	Patent family member(s)	Publication date	
US 2011032328	A1	10-02-2011	CN 102474639 A	23-05-2012
			EP 2462746 A1	13-06-2012
			US 2011032328 A1	10-02-2011
			WO 2011017474 A1	10-02-2011
-----				
WO 2011013030	A1	03-02-2011	CN 102474638 A	23-05-2012
			EP 2460360 A1	06-06-2012
			KR 20120049292 A	16-05-2012
			US 2012120200 A1	17-05-2012
			WO 2011013030 A1	03-02-2011
-----				
WO 2010021666	A1	25-02-2010	CN 102124742 A	13-07-2011
			EP 2329653 A1	08-06-2011
			JP 2012500564 A	05-01-2012
			KR 20110057162 A	31-05-2011
			US 2011142138 A1	16-06-2011
			WO 2010021666 A1	25-02-2010
-----				
EP 2202992	A2	30-06-2010	CN 101771892 A	07-07-2010
			EP 2202992 A2	30-06-2010
			JP 2010158009 A	15-07-2010
			KR 20100076783 A	06-07-2010
			US 2010165081 A1	01-07-2010
-----				
US 2002015103	A1	07-02-2002	NONE	
-----				