

July 15, 1941.

G. A. MATTHEWS

2,249,662

INTERLOCKING CIRCUIT BREAKER

Original Filed Nov. 5, 1934

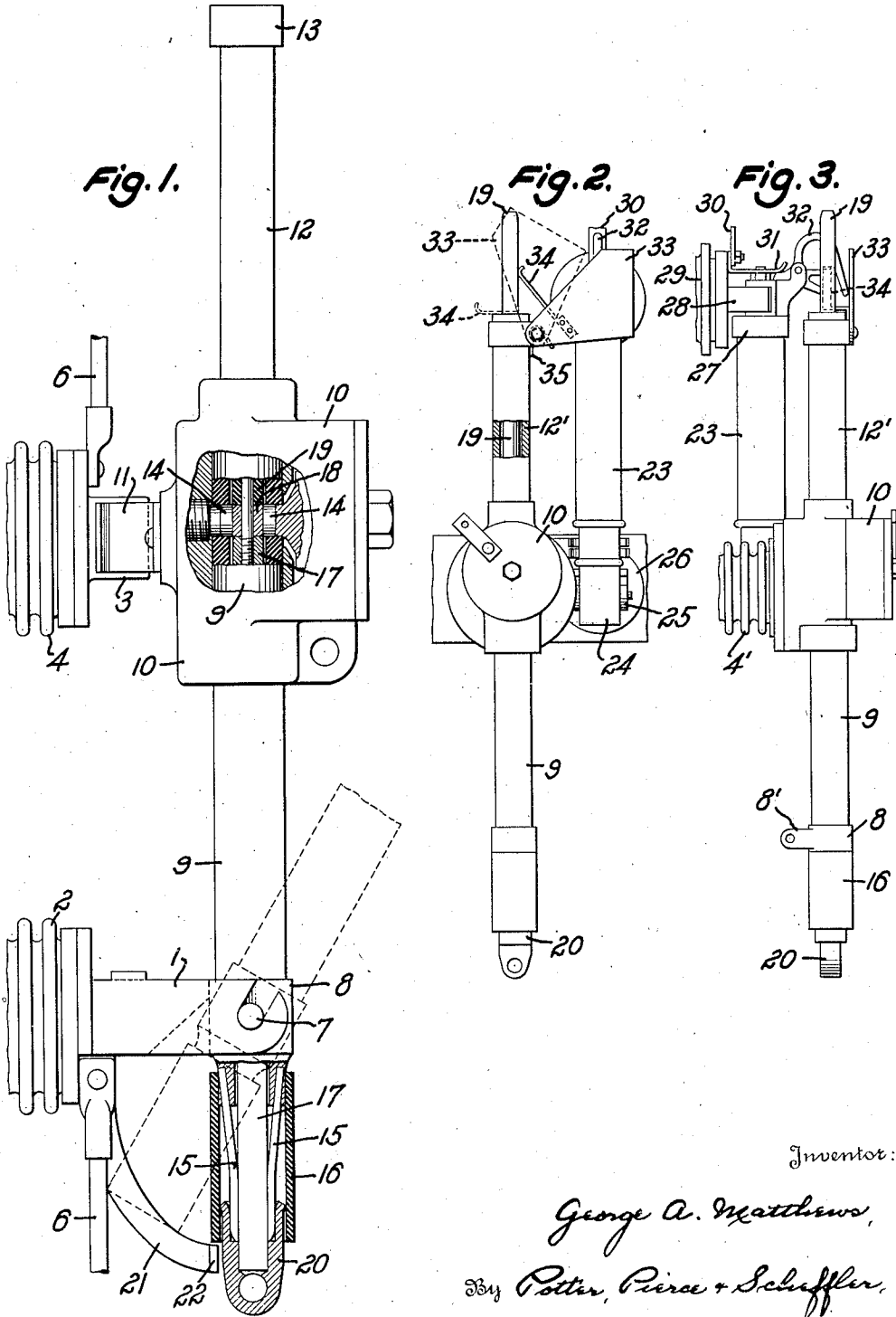

Inventor:

George A. Matthews,

By Potter, Pierce & Schuffler,
Attorneys.

UNITED STATES PATENT OFFICE

2,249,662

INTERLOCKING CIRCUIT BREAKER

George A. Matthews, Detroit, Mich., assignor to
The Detroit Edison Company, Detroit, Mich.,
a corporation of New York

Original application November 5, 1934, Serial No.
751,511, now Patent No. 2,167,665, dated August
1, 1939. Divided and this application May 13,
1939, Serial No. 274,462

3 Claims. (Cl. 200—50)

This invention relates to interlocking circuit breakers, and particularly to circuit breakers including a plurality of switch or circuit elements and locking mechanism for insuring the operation of the switch elements in a predetermined order.

This application is a division of my copending application, Ser. No. 751,511, filed Nov. 5, 1934, "Circuit breaker" which matured into Patent No. 2,167,665 on August 1, 1939. That patent includes a detailed description of and claims to the telescoping type circuit breaker that is herein claimed in combination with a circuit element, which may be a part of the de-ionizing circuit breaker or an independent circuit element, and latch mechanism for preventing the removal of the circuit element from closed circuit position so long as the circuit breaker is closed.

An object of the invention is to provide a multiple break circuit breaker including a manually operable circuit breaker or switch of the telescoping rod type, a second switch member removably mounted in spaced terminals, and a latch member cooperating with the telescoping rod to prevent removal of the second switch member from its terminals so long as the telescoping rod is in circuit closing position. An object is to provide a multiple break circuit breaker including a switch having a rod telescoped into an insulating tube having spaced contacts that are bridged by the telescoping rod, spaced terminals in which the insulating tube is removably mounted, and a latch member cooperating with the telescoping rod to prevent removal of the insulating tube from the terminals when the telescoping rod is in circuit closing position. A further object is to provide a circuit breaker including a switch of the telescoping rod type, a fuse cartridge in series with the switch, and a latch member cooperating with the telescoping rod to prevent removal of the fuse cartridge so long as the switch is closed.

These and other objects and advantages of the invention will be apparent from the following specification when taken with the accompanying drawing in which:

Fig. 1 is a side elevation, with parts in section, of one embodiment of the invention;

Fig. 2 is a front view, partly in section, of another embodiment; and

Fig. 3 is a side elevation of the same.

In the drawing, the reference numeral 1 identifies a hook or hinge terminal that is carried by an insulator 2 in spaced relation to a tongue terminal 3 on an insulator 4. The line conduc-

tors 6 are connected to the respective terminals in the usual manner. The hinge terminal 1 is notched to receive the pivot pins 7 of the tubular contact member 8 at the lower end of a tube 9 of organic insulating material such as horn fibre. The upper contact member is a housing or chamber 10 to which the jaw 11 is secured in position to engage the tongue terminal 3. The insulating tube 9 extends to or adjacent the top wall of the chamber 10 and opens into a metal tube 12 that extends well beyond the chamber 10 and is closed by a cap 13.

Cylindrical contacts 14 project slightly into the bore of the insulating tube 9 and are pressed towards each other by a spring, not shown, within the chamber 10. The lower contact member 8 carries a plurality of spring contact fingers 15 that are enclosed within an insulating sleeve 16 that projects below the contact member 8. The switch blade for completing a circuit between the upper contacts 14 and the spring fingers 15 is a metal rod 17 that is telescoped within the insulating tube 9, has an annular contact 18 at its upper end and carries a cylindrical extension 19 of organic insulating material that extends into the metal tube 12 when the blade is in switch closing position. A casting 20 at the lower end of the rod 17 has a transverse opening for receiving the hook of a fuse puller rod, and is counterbored at its upper end to provide an annular recess for receiving the ends of spring contact fingers 15 to force them against the rod 17.

The annular space between the rod 17 and the insulating tube 9 is of small size and the arc that is drawn between contact 18 and one of the fixed contacts 14 is quickly extinguished by the de-ionizing action of the vapors given off by the insulating tube 9 and the extension 19 when the rod 17 is withdrawn from the tube 9 to open the circuit. The tongue and jaw contacts 3, 11 would be badly burned if the circuit were opened under load at these contacts, and the present invention includes means for insuring an initial opening of the load circuit at the contacts within the chamber 10.

A latch member is secured to the lower insulator 2 and comprises an arm 21 depending below the insulator and terminating in a bar 22 that extends transversely of and closely adjacent the casting 20 at the lower end of the telescoping blade or rod 17. The latch bar 22 prevents clockwise rotation of the insulating tube 9 and associated elements so long as the rod 17 is telescoped within the tube 9 to complete the circuit

between the line conductors 6. Upon the complete removal of the telescoping blade member, the tube assembly of the circuit breaker may be rocked clockwise, as shown in dotted lines, and completely removed from the spaced terminals 1, 3.

In the embodiment shown in Figs. 2 and 3, the circuit element that is latched against removal by the closed circuit breaker is a fuse cartridge 23 that has a lower conductive member 24 pivotally and removably supported by a hinge terminal 25 that is carried by an insulator 26, and an upper conductive member 27 that has a blade extension for reception within a jaw terminal 28 on an insulator 29. A line terminal 30 engages the spring latch 31 that interlocks with the top of the conductive member 27 and may be lifted by clockwise motion of the release member 32 that is pivoted to the member 27.

The telescoping switch is substantially as previously described, but the chamber 10 at the upper end of insulating tube 9 is fixed to the insulator 4', and the second line terminal comprises a lug 8' on the conductive member 8 at the lower end of the tube 9. The chamber 10 is conductively connected to the fuse hinge terminal 25 and the insulator extension 19 of the telescoping blade projects above the open end of the tube 12' to operate the latch mechanism. The latch comprises a plate 33 that is pivoted upon the upper end of tube 12' and has an arm 34 that is engaged by the insulator extension 19, when the circuit breaker is closed, to prevent access to the fuse release member 32. A coil spring 35 moves the latch plate 33 counterclockwise into inoperative position, as shown in dotted line in Fig. 2, when the telescoping blade is withdrawn to open the circuit breaker.

The circuit from the upper terminal 30 to the lower terminal 8' is through the fuse cartridge 23 and the circuit breaker. The circuit cannot be opened at the upper fuse assembly contacts 27, 28 except by first opening the de-ionizing circuit breaker by dropping the telescoping blade assembly to carry the insulator extension 19 out of engagement with the arm 34 of the latch plate.

The described embodiments are illustrative of the invention and it is to be understood that other arrangements of the telescoping type circuit breaker and interlocked circuit element fall within the spirit of my invention as set forth in the following claims.

I claim:

1. A multiple break circuit breaker comprising a switch of the type including a blade telescoped within a tubular member to close the switch, a circuit member having a pair of spaced contacts, pivot pins carried by one of said contacts, spaced terminal members for engagement by said contacts, one of said terminal members being a hinge terminal upon which said circuit member is removably and pivotally supported by said pivot pins, and means at the end of said tubular member and cooperating with said blade when the latter is telescoped within the tubular member to prevent the separation of said circuit member contacts from said terminal members.

2. A multiple break circuit breaker as claimed in claim 1, wherein said circuit member comprises said tubular member.

3. A multiple break circuit breaker as claimed in claim 1, wherein said circuit member comprises a fuse cartridge in series with said circuit breaker.

4. A circuit interrupting device comprising a hinge terminal and a jaw terminal, blade means pivoted upon said hinge terminal for movement into and out of engagement with said jaw terminal for completing an electrical circuit through said means, said blade means including cooperable contacts movable relatively to open and close the circuit through said blade means, and means operative when the cooperable contacts are closed to prevent movement of said blade means out of engagement with the jaw terminal, and to enable disengagement therefrom when the cooperable contacts are opened.

5. A circuit interrupting device comprising a tubular member of insulating material hinged at one end for swinging movement, contacts at both ends of said member, stationary terminal means engaged and disengaged by the contact at the free end of said member in response to its swinging movement, conducting rod means insertable into said member to complete a circuit between said contacts, and means operable to retain the contact at the free end of the member in engagement with said terminal means so long as the rod means is in said member.

6. In a device of the character described, a hingedly mounted fuse swingable to open and closed positions, said fuse having an element operable to latch and unlatch the fuse against swinging movement, cooperable contacts in series circuit with said fuse adapted to open and close the circuit relative to said fuse, a member mounted for reciprocating movement and carrying one of said contacts, and latch-releasing means operable in response to movement of said reciprocating member for the opening of said contacts, whereby the movement of said element to unlatched position is prevented until said contacts are opened.

7. In combination with a plunger type switch having a movable plunger adapted to close and open an electrical circuit, a fuse in said circuit removably mounted in fuse clips, a latch for retaining said fuse in said fuse clips, and means operable in response to the movement of said plunger for displacing said latch into position to prevent removal of the fuse from its clips so long as the electrical circuit is closed.

8. In combination with a plunger type switch having a movable plunger adapted to close and open an electrical circuit, a fuse in said circuit, said fuse being hingedly mounted for swinging movement to open and closed positions relative to said circuit, and a barrier movable into and out of the path of movement of said fuse in response to the movement of the said plunger, whereby movement of the fuse to open position is prevented so long as the electrical circuit is closed by said plunger.

GEORGE A. MATTHEWS.