

(19) World Intellectual Property Organization
International Bureau



(43) International Publication Date
28 September 2006 (28.09.2006)

PCT

(10) International Publication Number
WO 2006/102450 A2

(51) International Patent Classification:
A45C 11/00 (2006.01) B65D 85/38 (2006.01)
B65D 81/22 (2006.01)

[US/US]; 210 East Sugar Street, Mt. Vernon, OH 43050 (US).

(21) International Application Number:
PCT/US2006/010465

(74) Agents: JOHNSON, Philip S. et al.; Johnson & Johnson, One Johnson & Johnson Plaza, New Brunswick, NJ 08933 (US).

(22) International Filing Date: 22 March 2006 (22.03.2006)

(81) Designated States (unless otherwise indicated, for every kind of national protection available): AE, AG, AL, AM, AT, AU, AZ, BA, BB, BG, BR, BW, BY, BZ, CA, CH, CN, CO, CR, CU, CZ, DE, DK, DM, DZ, EC, EE, EG, ES, FI, GB, GD, GE, GH, GM, HR, HU, ID, IL, IN, IS, JP, KE, KG, KM, KN, KP, KR, KZ, LC, LK, LR, LS, LT, LU, LV, LY, MA, MD, MG, MK, MN, MW, MX, MZ, NA, NG, NI, NO, NZ, OM, PG, PH, PL, PT, RO, RU, SC, SD, SE, SG, SK, SL, SM, SY, TJ, TM, TN, TR, TT, TZ, UA, UG, US, UZ, VC, VN, YU, ZA, ZM, ZW.

(25) Filing Language: English

(26) Publication Language: English

(30) Priority Data:
11/086,016 22 March 2005 (22.03.2005) US

(71) Applicant (for all designated States except US): JOHNSON & JOHNSON VISION CARE, INC. [US/US]; 7500 Centurion Parkway, Suite 100, Jacksonville, FL 32256 (US).

(84) Designated States (unless otherwise indicated, for every kind of regional protection available): ARIPO (BW, GH, GM, KE, LS, MW, MZ, NA, SD, SL, SZ, TZ, UG, ZM, ZW), Eurasian (AM, AZ, BY, KG, KZ, MD, RU, TJ, TM), European (AT, BE, BG, CH, CY, CZ, DE, DK, EE, ES, FI, FR, GB, GR, HU, IE, IS, IT, LT, LU, LV, MC, NL, PL, PT, RO, SE, SI, SK, TR), OAPI (BF, BJ, CF, CG, CI, CM, GA, GN, GQ, GW, ML, MR, NE, SN, TD, TG).

(72) Inventors; and

(75) Inventors/Applicants (for US only): TOKARSKI, Michael [US/US]; 500 N. Lakewood Run, Ponte Vedra, FL 32082 (US). PECK, James [US/US]; 13587 Osprey Point, Jacksonville, FL 32224 (US). DZWILL, Edward [US/US]; 9 Blossom Lane, Flemington, NJ 08822 (US). BROCK, George [US/US]; 919 Garrison Drive, St. Augustine, FL 32092 (US). SMITH, Roger W. [US/US]; 4351 Harrisburg Pike, Grove City, OH 43123 (US). ULRICH, Michael Scott [US/US]; 700 Wiltshire Road, Columbus, OH 43204 (US). SANDER, Raymond J.

Published:
— without international search report and to be republished upon receipt of that report

For two-letter codes and other abbreviations, refer to the "Guidance Notes on Codes and Abbreviations" appearing at the beginning of each regular issue of the PCT Gazette.

(54) Title: OPHTHALMIC LENS PACAKGE WITH INTERNAL DRAINAGE MEMBER

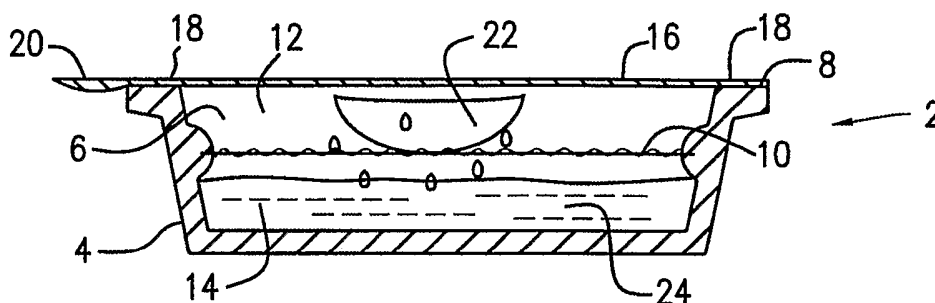

(57) Abstract: An ophthalmic lens package comprises a shell having an internal cavity accessible through an opening in the shell and a drainage member that divides the internal chamber into an upper chamber and a lower chamber. The drainage member is permeable to aqueous liquids and is arranged to allow drainage of liquid from the upper chamber to the lower chamber. This arrangement of the ophthalmic lens package allows the consumer to retrieve the lens from the upper chamber without handling any significant amount of saline solution.

WO 2006/102450 A2

OPHTHALMIC LENS PACKAGE WITH INTERNAL DRAINAGE MEMBER

Field of Invention

The present invention relates to packages for the storage and shipping of ophthalmic lenses, particularly soft contact lenses. More particularly, the present invention relates to packages having an internal drainage system that allows separation of the ophthalmic lens from the solution when the lens is removed from the package.

Background of the Invention

Soft contact lenses have become increasingly popular since they were first introduced in the 1970's. Due to progressive reductions in manufacturing costs, soft contact lenses are now an attractive and economical choice for the consuming public. Such lenses may be frequently replaced by the consumers (e.g., on a daily or weekly basis) and do not need to be cleaned or sterilized as often as traditional contact lenses. Of course, the consumer desires to keep a supply of lenses on hand that is commensurate with the frequency with which the lenses are replaced. Therefore, consumer demand for disposable soft contact lenses has led to a need for disposable packages that are easy to use and inexpensive. The packages should be constructed to provide safe storage and shipping for the lenses. It is also desirable that the individual packages be as small as possible, so that they may be easily and unobtrusively stored and carried.

Soft contact lenses are often packaged and stored in a hydrated state, which requires that they be sealed in packages with a storage solution. One

widely-used package is the "blister pack", which, in general, comprises a rigid plastic container having a flat upper surface with a concave-shaped well that contains a single ophthalmic lens with a quantity of solution. The well is covered with a flexible cover that is sealed along the perimeter of the upper surface. The blister packs are boxed for shipping and storage until a lens is needed by a consumer. The consumer then peels back the flexible cover from the blister pack to expose the ophthalmic lens. The consumer then pours the lens out into his or her hand, together with the saline solution, and places the lens on the tip of his or her finger for application to the eye.

10 A need remains for ophthalmic lens packaging systems that include a solution for storage and shipping of the ophthalmic lenses, but allow the solution to be separated from the lens at the time that the lens is removed from the package.

Brief Description of the Drawings

15 For a more complete understanding of the present invention, reference is made to the following detailed description of the present invention considered in conjunction with the accompanying drawings, in which:

FIG. 1 is a cross-sectional view of an embodiment of a ophthalmic lens package according to the present invention in which the ophthalmic lens package is sealed for shipping and storage.

FIG. 2 is a cross-sectional view of the ophthalmic lens package of FIG. 1 in which the ophthalmic lens package has been opened to provide access to a contact lens.

FIG. 3 is a perspective view of the sealed ophthalmic lens package of FIG. 1.

FIG. 4 is a perspective view of the opened ophthalmic lens package of FIG. 1.

5 FIG. 5 is a top view of the shell of another embodiment of a ophthalmic lens package according to the present invention.

FIG. 6 is a side view of the ophthalmic lens package of FIG. 5 in which the ophthalmic lens package has been sealed for shipping and storage.

FIG. 7 is a cross-sectional view of the shell of FIG. 5.

10 FIG. 8 is a frontal view of a plurality of ophthalmic lens packages according to the present invention assembled for display and storage.

Detailed Description of the Invention

An ophthalmic lens package, comprising:

15 a shell defining an opening and having an internal cavity accessible through said opening; and

dividing means for dividing said cavity into an upper chamber and a lower chamber, said upper chamber having an interior accessible through said opening, said dividing means allowing the permeation of aqueous liquid between said upper
20 chamber and said lower chamber.

As used herein the term "ophthalmic lens" refers to a device that resides on an eye, including, but not limited to, hard contact lenses, soft contact lenses, intra-

ocular lenses and overlay lenses and preferably soft contact lenses. A first preferred embodiment of an ophthalmic lens package **2** according to the present invention is shown in FIGS. 1-4. Referring to FIGS. 1-4, an ophthalmic lens package **2** has a shell **4** with an interior cavity **6** and an upwardly-facing perimeter rim **8**. A drainage member **10**, such as a mesh or a perforated plastic sheet, is secured to the shell **4** so as to divide the interior cavity **6** into an upper chamber **12** and a lower chamber **14**. A sealing cover **16**, such as a foil member, is used to seal the interior cavity **6** of the shell **4**. A perimeter portion **18** of the sealing cover **16** is secured to the upwardly-facing perimeter rim **8** of the shell **4** so as to form a continuous liquid-tight seal along the entire upwardly-facing perimeter rim **8**. The sealing cover **16** is provided with a tab **20** that extends beyond the perimeter portion **18** of the sealing cover **16** so that the tab **20** may be used as a handle for separating the sealing cover **16** from the shell **4**. The consumer gains access to ophthalmic lens **22** by grasping the tab **20** and pulling it upward and across the upwardly-facing rim **8** of the shell **4**, thereby separating the sealing cover **16** from the shell **4** and exposing ophthalmic lens **22** for retrieval by the consumer (see FIGS. 2 and 4).

The drainage member **10** is arranged within the interior cavity **6** so that ophthalmic lens **22** may rest in an inverted position on the drainage member **10**, within the upper chamber **12**, without contacting the sealing cover **16** that is sealed to the shell **4**. When ophthalmic lens package **2** is prepared for shipping or storage of ophthalmic lens **22**, a volume of saline solution **24** is included within the interior cavity **6** of the shell **4**. The volume of saline solution **24** is less than the

volume of the lower chamber **16** so that the entire volume of saline solution **24** may be contained within the lower chamber **16** when ophthalmic lens package **2** is stored in a horizontal position (see, e.g., FIGS. 1 and 2).

When ophthalmic lens container **2** is shipped or stored in a horizontal
5 position, substantially all of the saline solution **24** remains in the lower chamber **14**. Water vapor from the saline solution **24** permeates into the upper chamber **12** through the drainage member **10**, so that ophthalmic lens **22** remains hydrated in the water vapor-saturated atmosphere in the upper chamber **12**. In the event that a portion of the saline solution **24** enters the upper chamber **12**, the saline solution
10 **24** will drain back through the drainage member **10** into the lower chamber **14** when ophthalmic lens package **2** is returned to a horizontal position (see, e.g., FIGS. 1 and 2). Such drainage allows the consumer to remove the lens without inserting his or her finger into standing saline solution. Preferably the drainage leaves ophthalmic lens **22** substantially free of the saline solution **24** when the
15 consumer retrieves ophthalmic lens **22**. Therefore, it is preferable that the drainage member **10** be arranged to allow rapid and complete drainage of the saline solution **24** from the upper chamber **12**. The drainage member **10**, therefore, is preferably an open mesh, although, as an alternative, a perforated member of a hydrophobic plastic material may be used.

20 A second preferred embodiment of an ophthalmic lens package **2** according to the present invention is presented in FIGS. 5-7. Reference numbers for features that the second embodiment has in common with the first embodiment

are the same as those reference numbers used in the description of the first embodiment, incremented by one hundred (100).

Referring to FIGS. 5-7, an ophthalmic lens package **102** has a shell **104** with an interior cavity **106** and an upwardly-facing perimeter rim **108**. A drainage member **110**, which is, in this second embodiment, a perforated member of a hydrophobic plastic, is molded into the shell **104** and arranged so as to divide the interior cavity **106** into an upper chamber **112** and a lower chamber **114**. A sealing cover **116**, such as a foil member (see FIG. 6), is used to seal the interior cavity **106** of the shell **104**. A perimeter portion **118** of the sealing cover **116** is secured to the upwardly-facing perimeter rim **108** of the shell **104** so as to form a continuous liquid-tight seal along the entire upwardly-facing perimeter rim **108**. The sealing cover **116** is provided with a tab **120** that extends beyond the perimeter rim **108** so that the tab **120** may be used as a handle for separating the sealing cover **116** from the shell **104**. The drainage member **110** is arranged within the interior cavity **106** so that a soft contact lens (not shown) may rest in an inverted position on the drainage member **110**, within the upper chamber **112**, without contacting the sealing cover **116** that is sealed to the shell **104**. When ophthalmic lens package **102** is prepared for shipping or storage of the ophthalmic lens, a volume of saline solution (not shown) is included within the interior cavity **106** of the shell **104**. The volume of saline solution is less than the volume of the lower chamber **114** so that the entire volume of saline solution may be contained within the lower chamber **114** when ophthalmic lens package **102** is stored in a horizontal position. Ophthalmic lens package **102** is further provided with a handle

portion **126** which extends from the shell **104** in a direction away from the interior cavity **106**. The handle portion **126** may be provided with a gripping surface, such as a thumb depression **128** with ridges **130**.

The consumer gains access to the ophthalmic lens in a similar manner to that described for the first embodiment (i.e., ophthalmic lens package **2**). The consumer grasps the handle portion **126** between the fingers of one hand and the tab **120** between the fingers of the other hand. The consumer then pulls the tab **120** upward and across the upwardly-facing rim **108** of the shell **104**, thereby separating the sealing cover **116** from the shell **104** and exposing the ophthalmic lens for retrieval by the consumer.

As with the first embodiment, the ophthalmic lens in the second embodiment (i.e., ophthalmic lens package **102**) remains hydrated during shipping and storage in the water vapor-saturated atmosphere in the upper chamber **112** from water vapor that has permeated from saline solution in the lower chamber **114**. Any portion of the saline solution that enters the upper chamber **112** drains through the drainage member **110** into the lower chamber **114** when ophthalmic lens package **102** is returned to a horizontal position, leaving the ophthalmic lens free of the saline solution.

The shell of the invention can be fabricated from a number of known materials, such as polypropylene, polyethylene, and the like. Ophthalmic lens packages **2**, **102** of the present invention can be fabricated to have an interior cavity with dimensions of about 2-3 cm by about 2-3 cm and a depth of about 0.5 cm, with its minimum dimensions limited only by the size of the ophthalmic lens to

be stored and the volume of saline solution (or other ophthalmic solutions containing ocular medicaments, wetting agents, antimicrobial agents and the like) to be provided. Preferably, the amount of solution is between about 900 μL and about 1,500 μL , more preferably between about 900 μL and about 1,000 μL . The
5 resulting small overall size of the ophthalmic lens package allows it to be easily and unobtrusively carried. The cover for the shell may be made from foil/polymer laminate or coextrusion, made of a metal layer, such as aluminum and one or more polymer layers, such as polypropylene, coating the metal layer. The cover materials may include any flexible material that acts as a barrier to air borne
10 contaminants and may be hermetically sealed to the shell.

A number of ophthalmic lens packages may also be conveniently stored. For example, FIG. 8 illustrates a storage and display arrangement **132** where six ophthalmic lens packages **2** are mounted on a pegboard card **134** with an overall size of about 12 cm by 18 cm.

15 It will be understood that the embodiments described herein are merely exemplary and that a person skilled in the art may make many variations and modifications without departing from the spirit and scope of the present invention. For instance, structures other than a film or foil may be used to seal the interior cavity of the ophthalmic lens package. Examples of such structures include plugs
20 or screw-top fittings. The shell of the ophthalmic lens case may have handle portions that are configured differently than the handle portion illustrated in the second embodiment and may have more than one handle portion. All such

variations and modifications, including those discussed within the detailed description, are intended to be included within the scope of the present invention.

We claim:

1. An ophthalmic lens package, comprising:
a shell defining an opening and having an internal cavity accessible through said opening; and
5 dividing means for dividing said cavity into an upper chamber and a lower chamber, said upper chamber having an interior accessible through said opening, said dividing means allowing the permeation of aqueous liquid between said upper chamber and said lower chamber.
2. The package of Claim 1, wherein said dividing means is arranged to
10 allow drainage of aqueous liquid from said upper chamber into said lower chamber.
3. The package of Claim 2, wherein said dividing means comprises a mesh.
4. The package of Claim 2, wherein said dividing means comprises a
15 plastic member having perforations therethrough.
5. The package of Claim 1, further comprising covering means for covering said opening and forming a liquid-tight seal with said shell.
6. The package of Claim 5, wherein said covering means includes a foil member.
- 20 7. The package of Claim 6, wherein said covering means has an edge with a grippable tab.
8. The package of Claim 1, wherein said interior of said upper chamber is sized and shaped to contain an ophthalmic lens entirely within said upper

chamber and said lower chamber has an interior that is sized to contain an aqueous liquid.

9. The package of Claim 1, wherein said opening is defined by a layer of material contiguous with said shell, said layer of material extending away from
5 said opening to form a handle that is grippable by a user.

10. The package of Claim 1, further comprising a grippable handle.

11. An ophthalmic lens package, comprising:

a shell defining an opening and having an internal cavity accessible through said opening; and

10 a drainage member permeable to aqueous liquids and arranged within said cavity so as to divide said cavity into an upper chamber and a lower chamber, said upper chamber having an interior accessible through said opening and in communication with said lower chamber through said drainage member.

12. The package of Claim 11, wherein said drainage member is
15 arranged to allow drainage of aqueous liquid from said upper chamber into said lower chamber.

13. The package of Claim 12, wherein said drainage member comprises a mesh.

14. The package of Claim 12, wherein said drainage member comprises
20 a plastic member having perforations therethrough.

15. The package of Claim 11, wherein said shell includes a rim which defines said opening, said package further comprising a cover extending over said opening and forming a liquid-tight seal with said rim.

16. The package of Claim 15, wherein said cover includes a foil member having an edge with a grippable tab.

17. The package of Claim 11, wherein said interior of said upper chamber is sized and shaped to contain an ophthalmic lens entirely within said upper chamber and said lower chamber has an interior sized to contain a quantity
5 of an aqueous liquid.

18. The package of Claim 11, wherein said opening is defined by a layer of material contiguous with said rim, said layer of material extending away from said opening to form a handle that is grippable by a user.

10 19. The package of Claim 11, further comprising a grippable handle.

20. A ophthalmic lens package, comprising:

a shell defining an opening and having an internal cavity accessible through said opening;

15 a drainage member permeable to aqueous liquids and arranged within said cavity so as to divide said cavity into an upper chamber and a lower chamber, said upper chamber having an interior accessible through said opening and in communication with said lower chamber through said drainage member;

a cover extending over said opening and in sealing contact with said shell so as to form a liquid-tight seal with said shell;

20 an ophthalmic lens contained entirely within said upper chamber;
and

a quantity of an aqueous solution contained within said cavity, said lower chamber having a volume sufficiently large to contain the entire quantity of said aqueous solution.

5

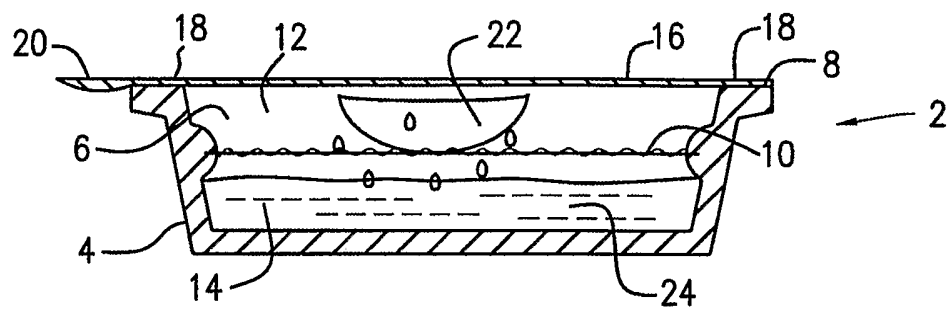

FIG. 1

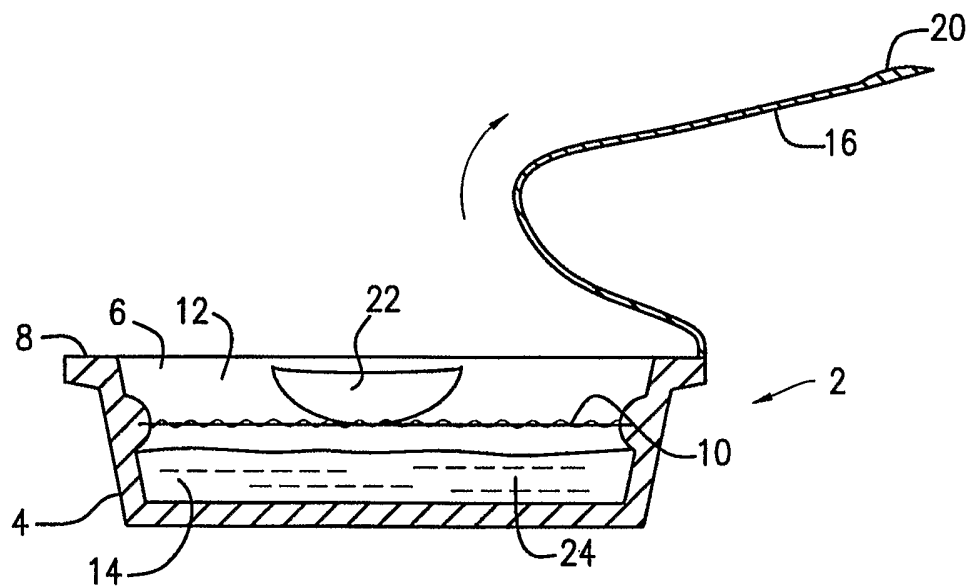

FIG. 2

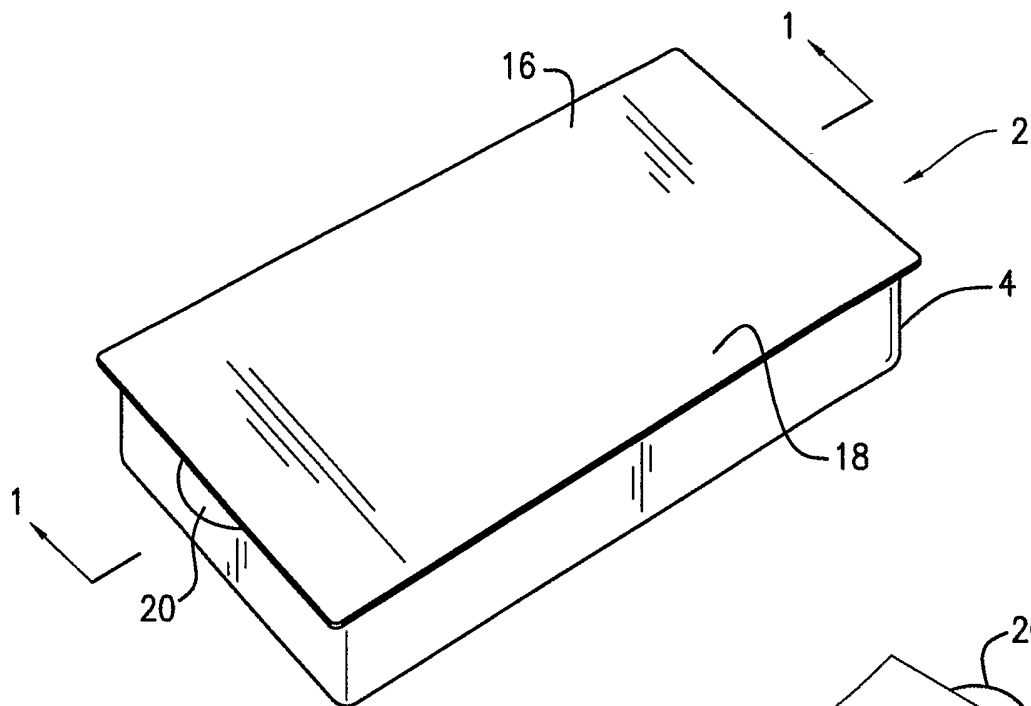

FIG. 3

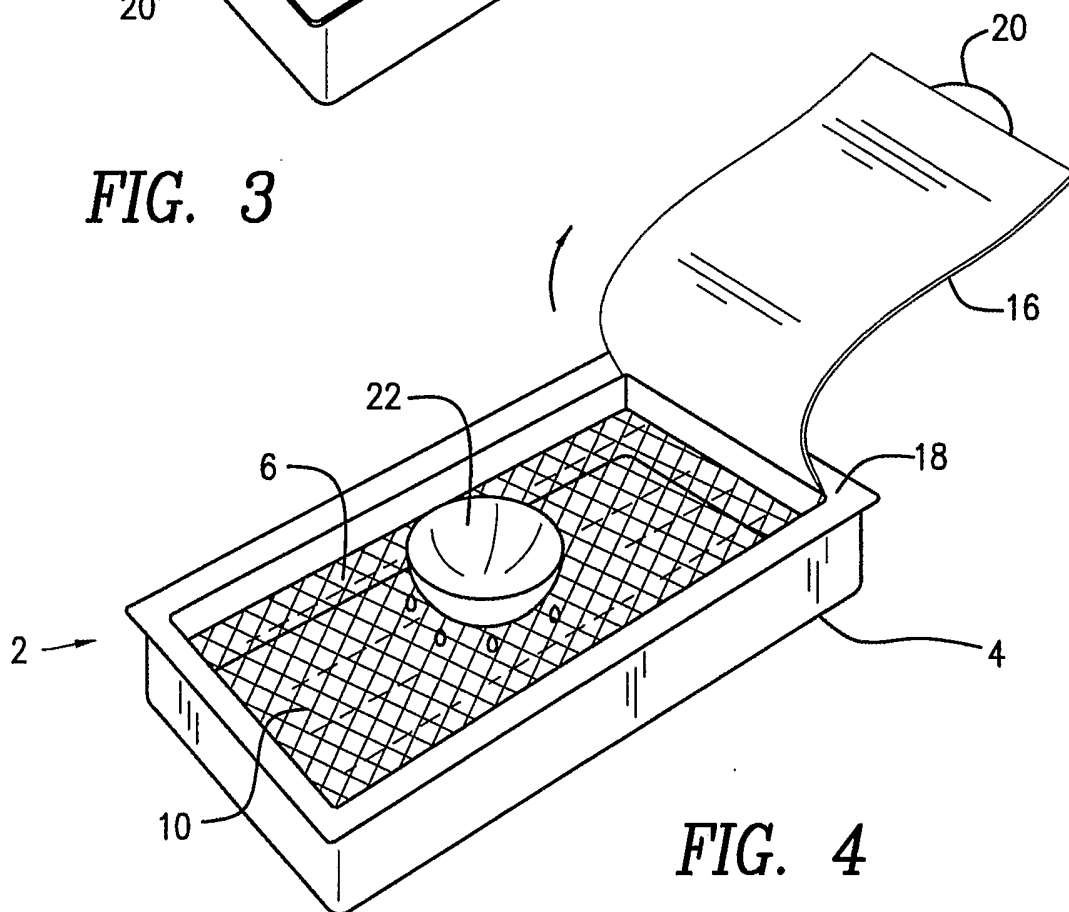

FIG. 4

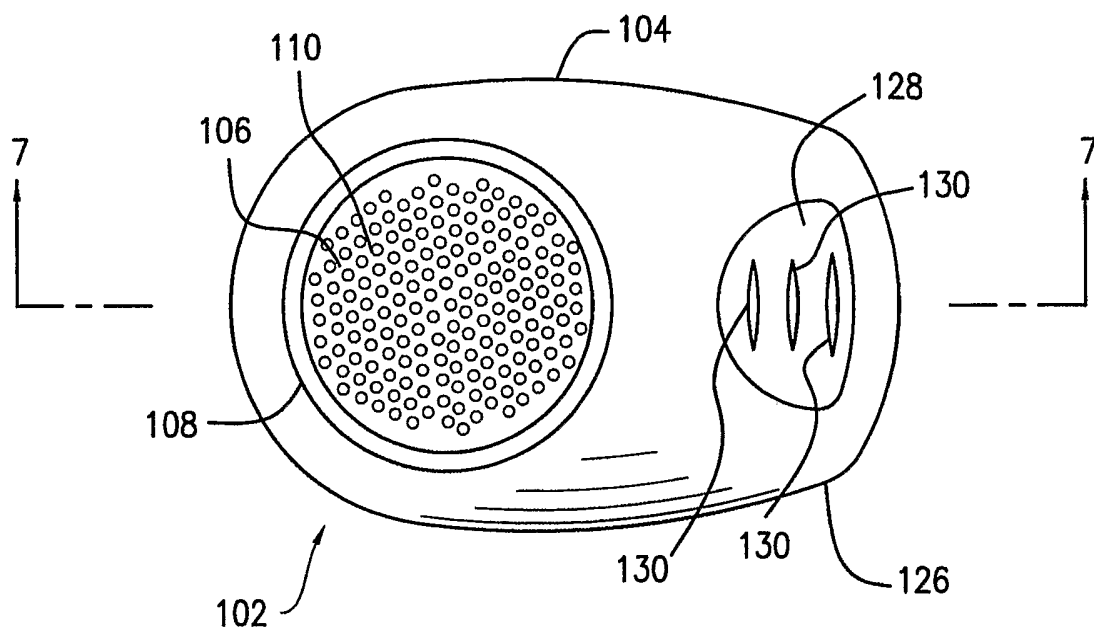

FIG. 5

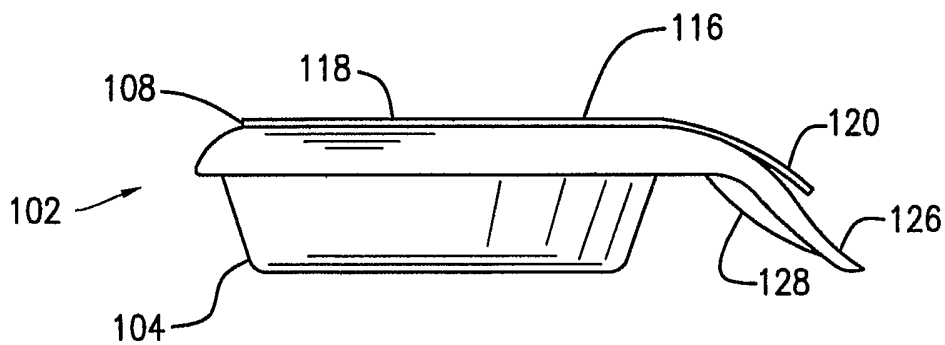

FIG. 6

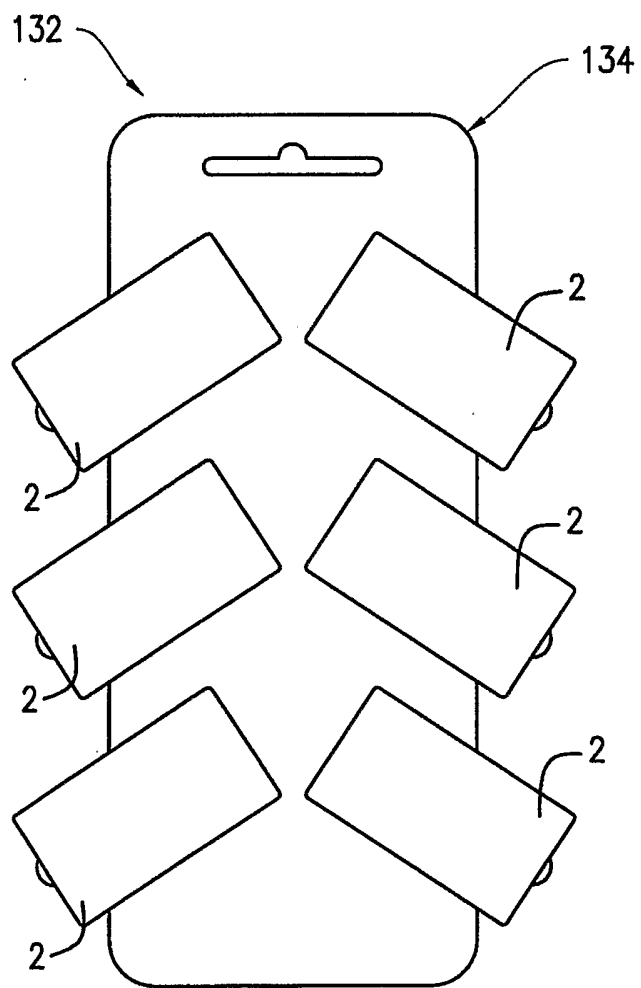

FIG. 8

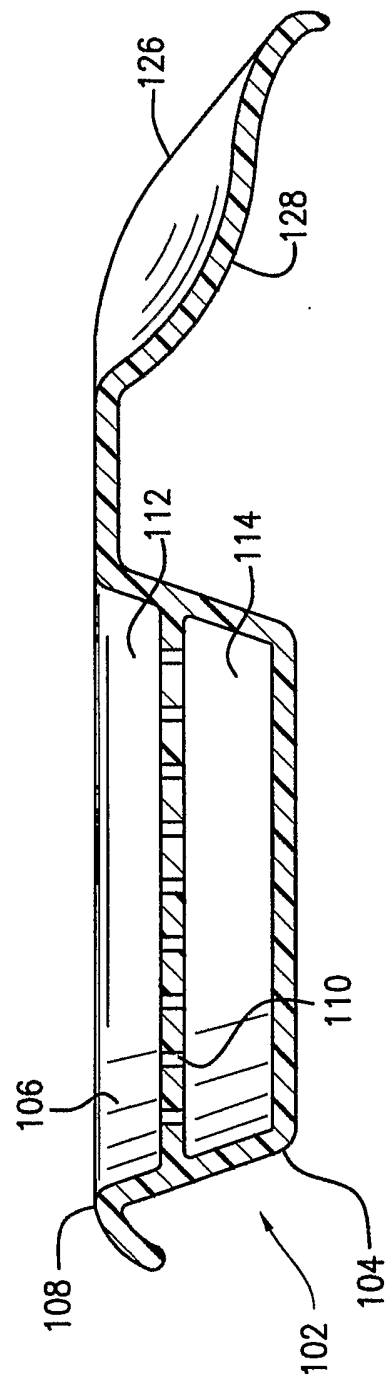

FIG. 7