

(12) **United States Patent**
Kruger

(10) **Patent No.:** **US 11,983,658 B1**
(45) **Date of Patent:** **May 14, 2024**

(54) **EXECUTION OF MACHINES BASED ON PERFORMANCE DATA**

(71) Applicant: **Starbucks Corporation**, Seattle, WA (US)

(72) Inventor: **Joshua J. Kruger**, Seattle, WA (US)

(73) Assignee: **Starbucks Corporation**, Seattle, WA (US)

(*) Notice: Subject to any disclaimer, the term of this patent is extended or adjusted under 35 U.S.C. 154(b) by 0 days.

(21) Appl. No.: **18/348,998**

(22) Filed: **Jul. 7, 2023**

Related U.S. Application Data

(63) Continuation-in-part of application No. 18/160,046, filed on Jan. 26, 2023.

(51) **Int. Cl.**
G06Q 10/08 (2023.01)
G06K 7/10 (2006.01)
G06Q 10/0639 (2023.01)

(52) **U.S. Cl.**
CPC **G06Q 10/08** (2013.01); **G06K 7/10861** (2013.01); **G06Q 10/0639** (2013.01)

(58) **Field of Classification Search**
None
See application file for complete search history.

(56) **References Cited**

U.S. PATENT DOCUMENTS

6,547,137 B1 *	4/2003	Begelfer	G06Q 10/08 235/380
2009/0230190 A1 *	9/2009	Chanez	G06Q 10/08 235/385
2011/0154046 A1 *	6/2011	Fradet	H04L 9/3247 713/179
2017/0061350 A1 *	3/2017	Smith	G06Q 10/06315
2019/0210806 A1 *	7/2019	Aida	G06Q 50/28

* cited by examiner

Primary Examiner — Suez Ellis

(74) *Attorney, Agent, or Firm* — Knobbe, Martens, Olson & Bear, LLP

(57) **ABSTRACT**

A system and method for tracking physical environment performance may include a label printer configured to print labels comprising a machine readable code, wherein the machine readable code contains item information associated with an item. The system may include production channels and scanners associated with the production channels; the scanner located at a first physical location of the physical environment and configured to scan the machine readable code. The system may obtain input data indicative of the production of the item and may determine performance data based on the input data. The system may cause implementation and/or execution of machines based on the performance data.

20 Claims, 12 Drawing Sheets

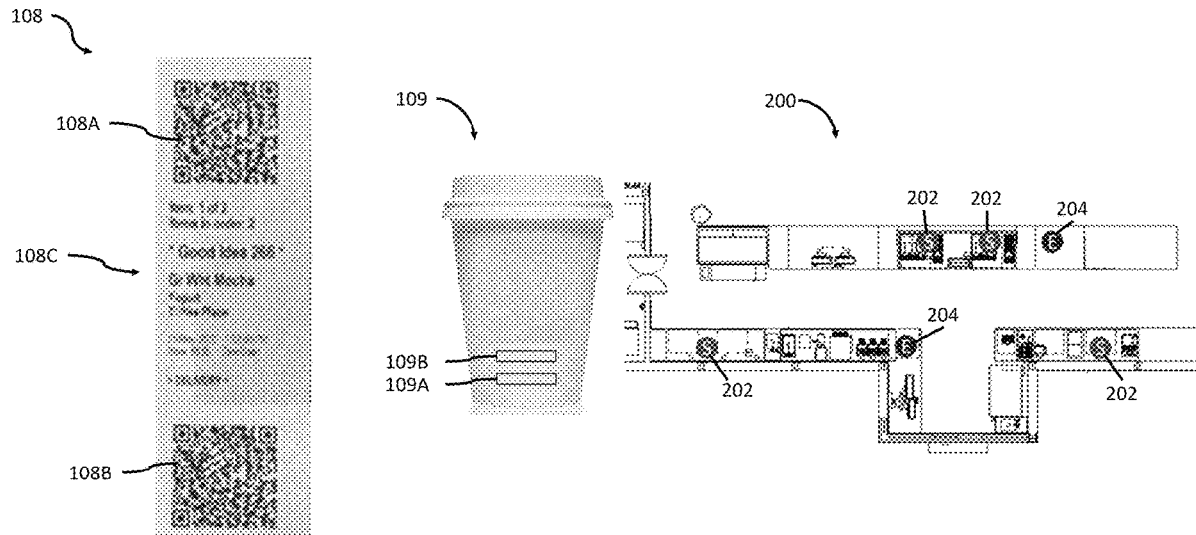

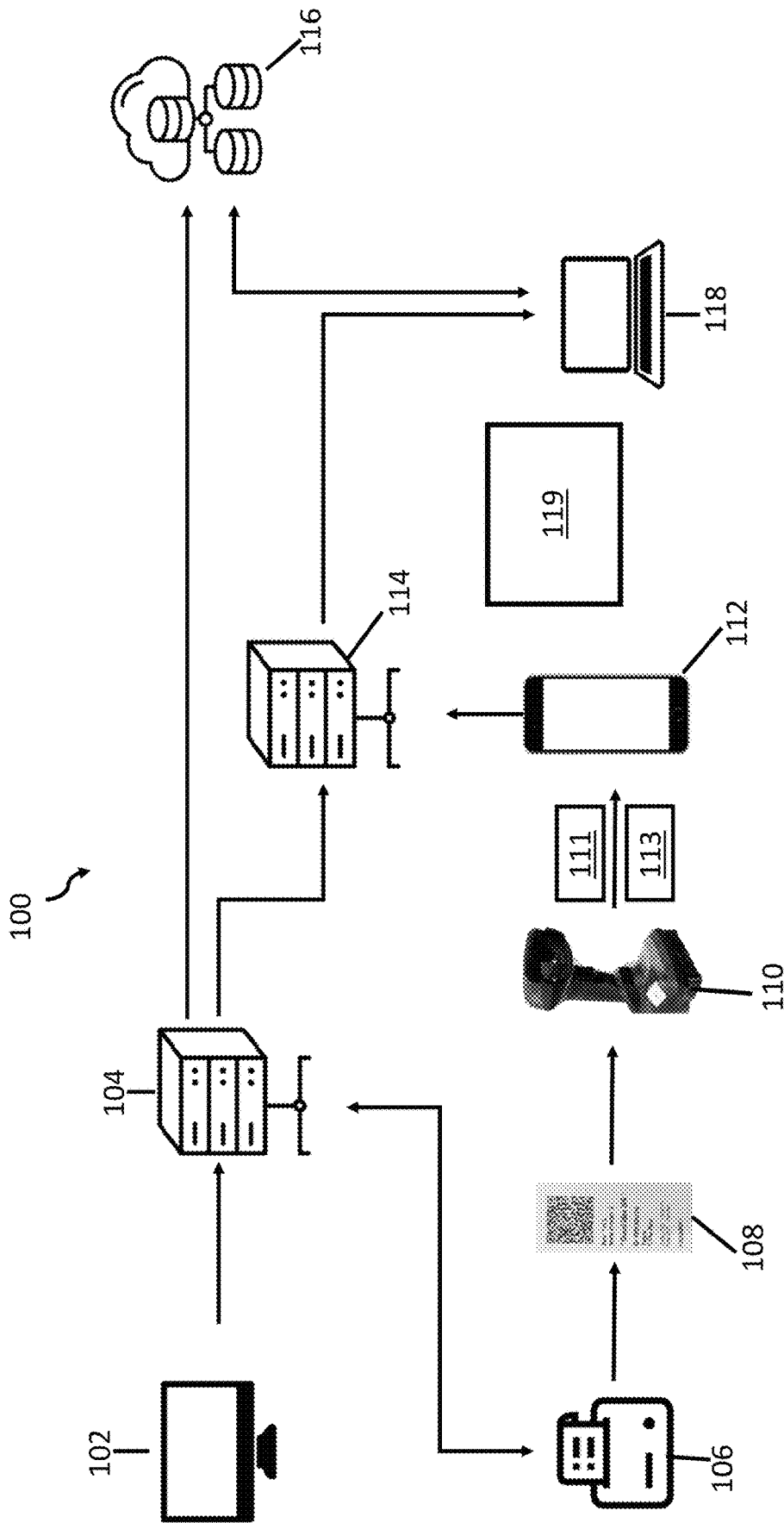

FIG. 1A

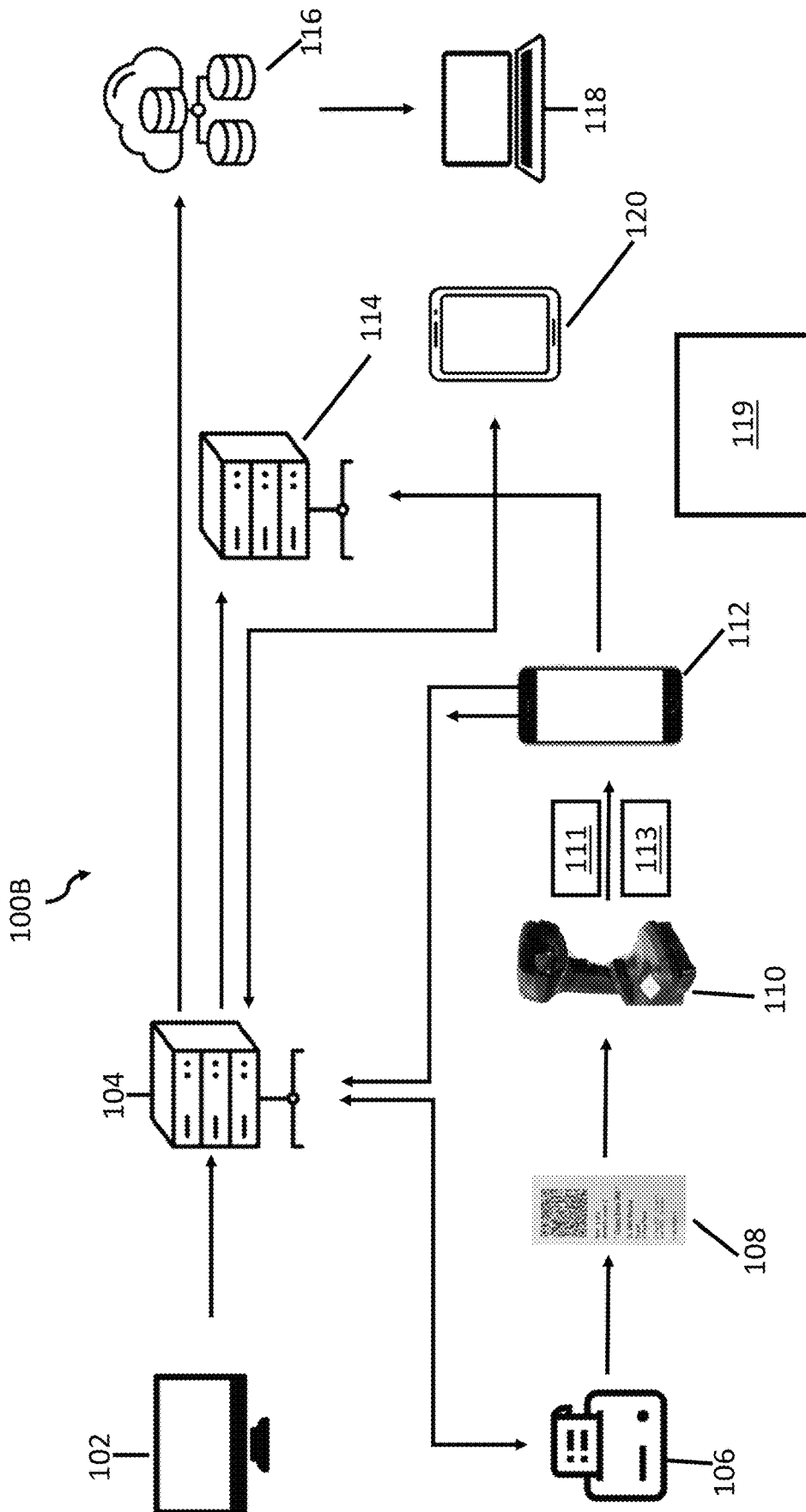

FIG. 1B

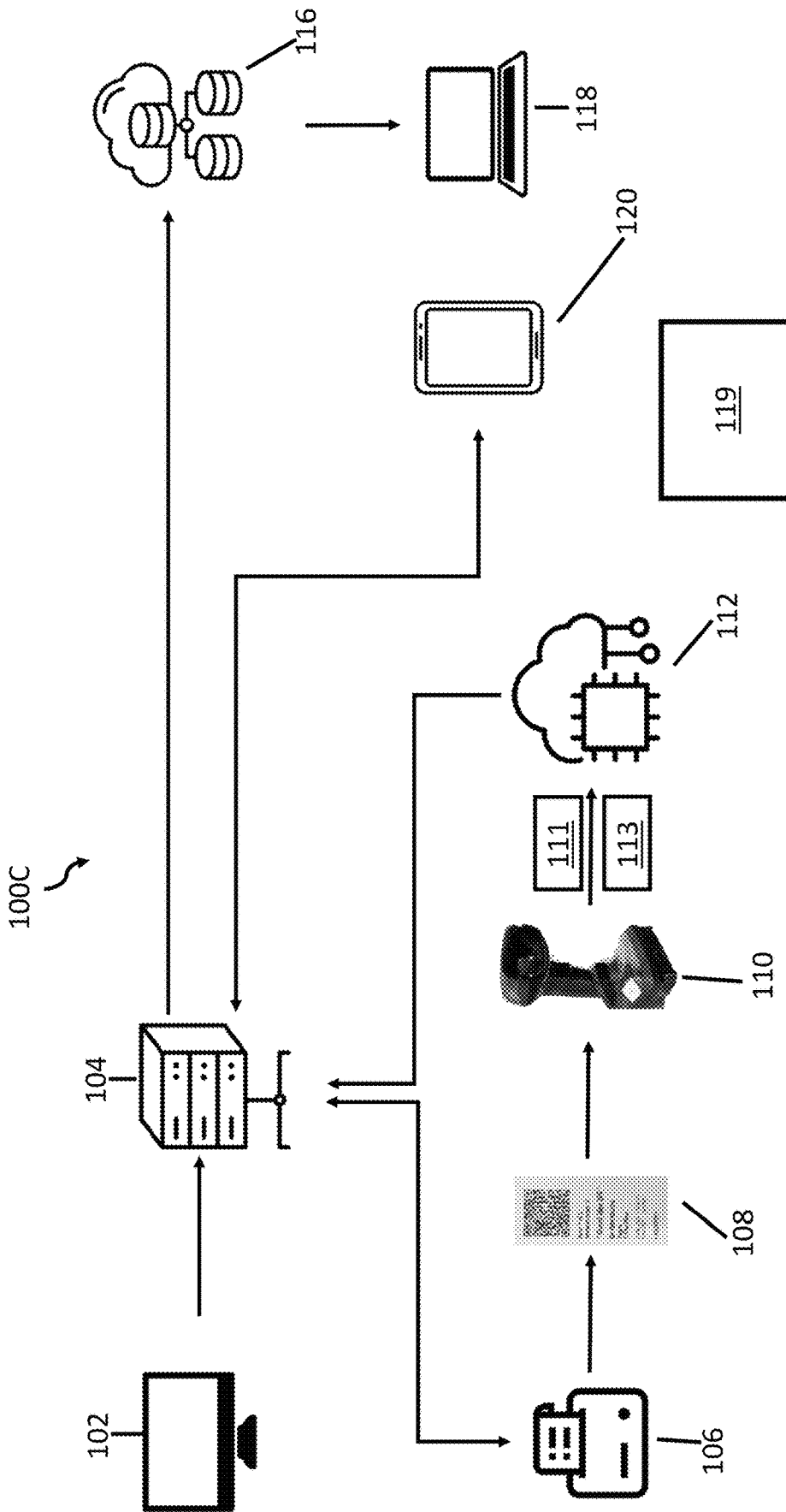

FIG. 1C

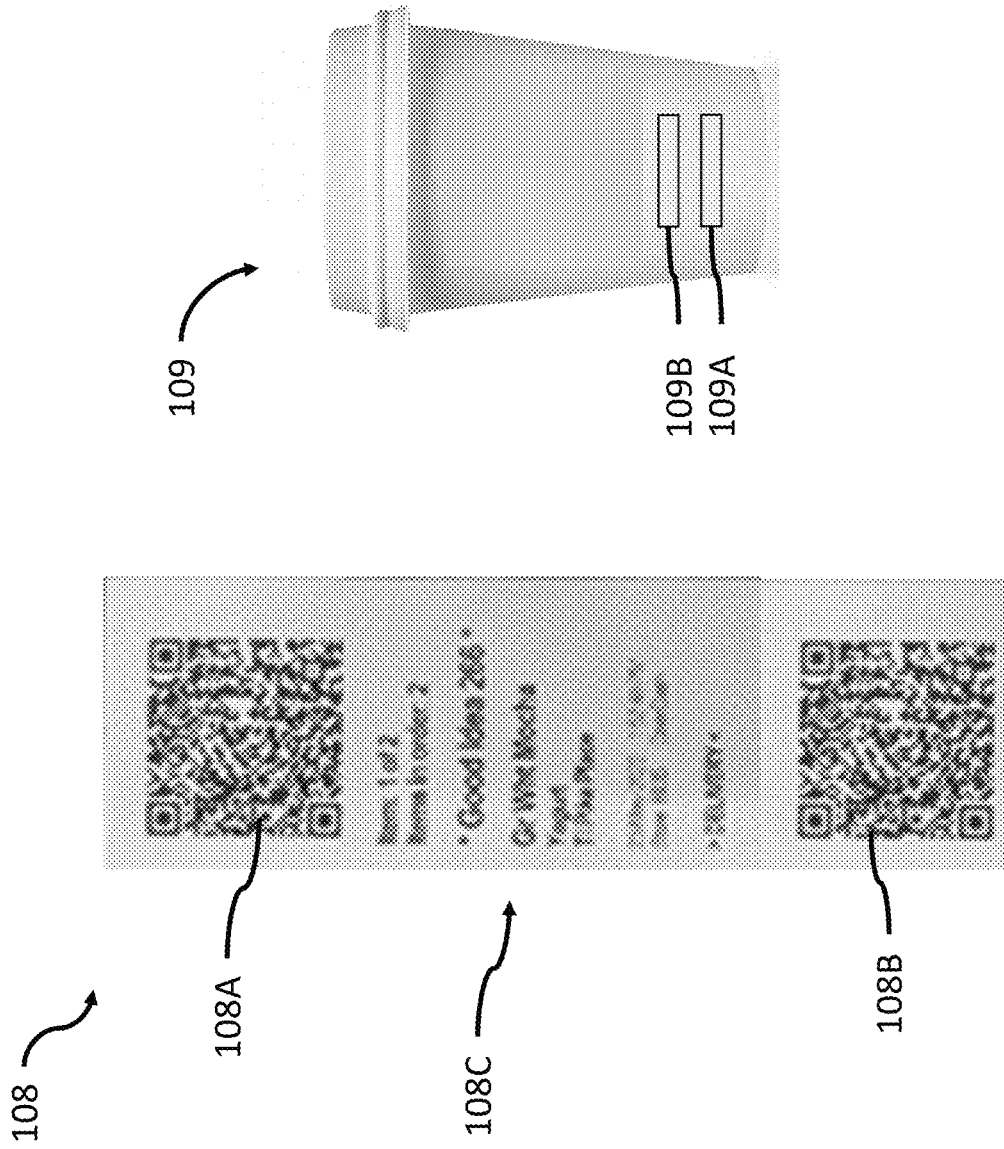

FIG. 1D

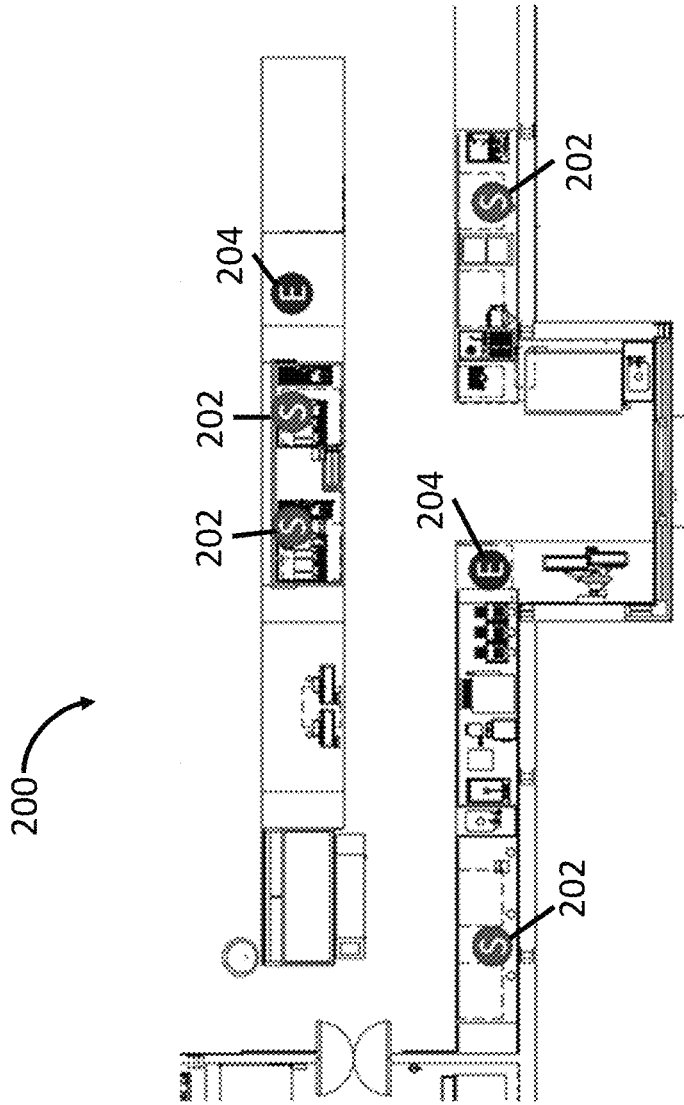

FIG. 2A

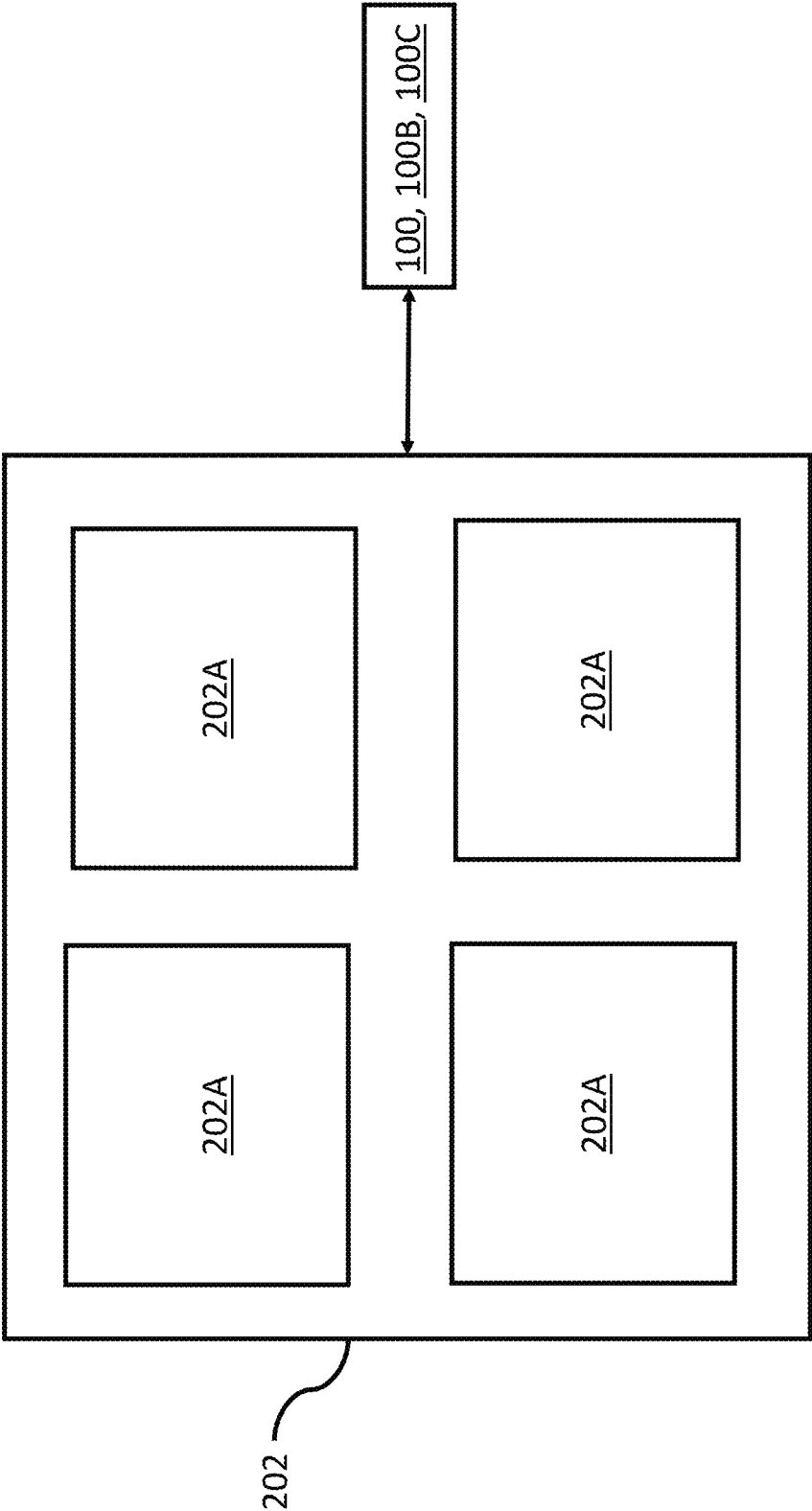

FIG. 2C

300

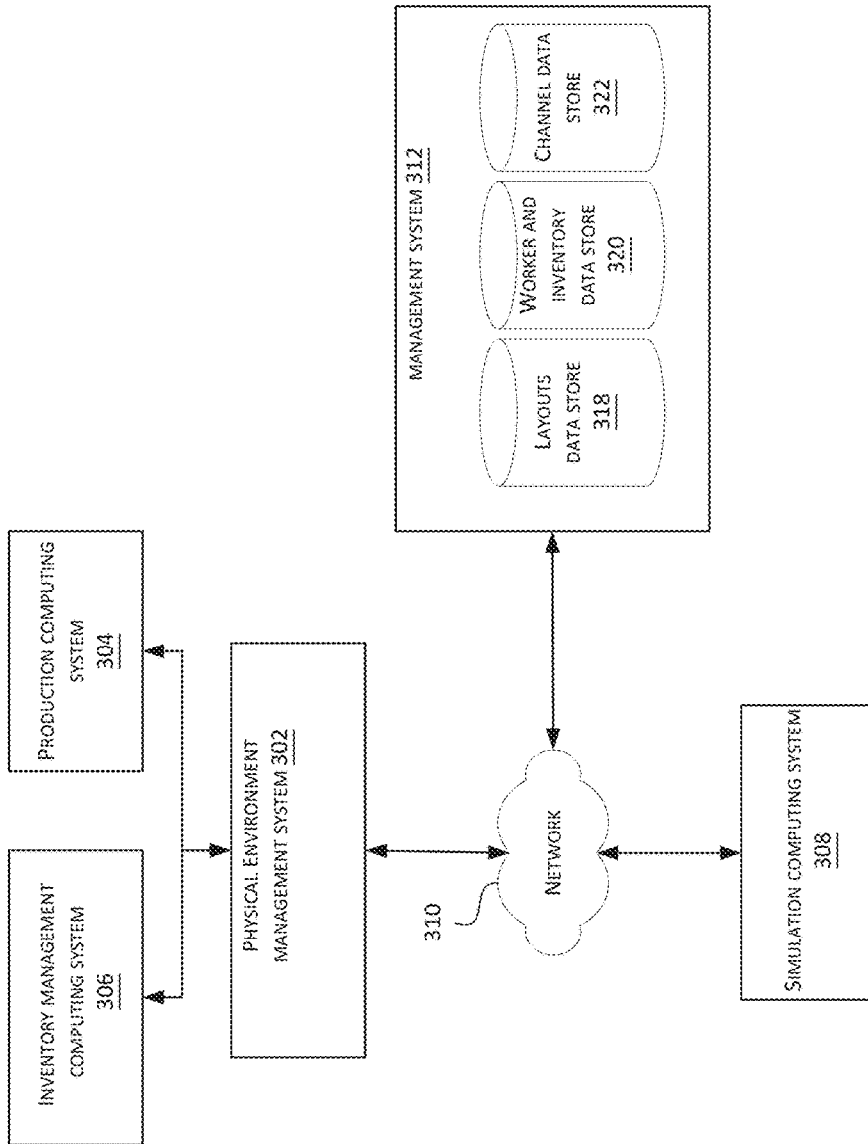

FIG. 3

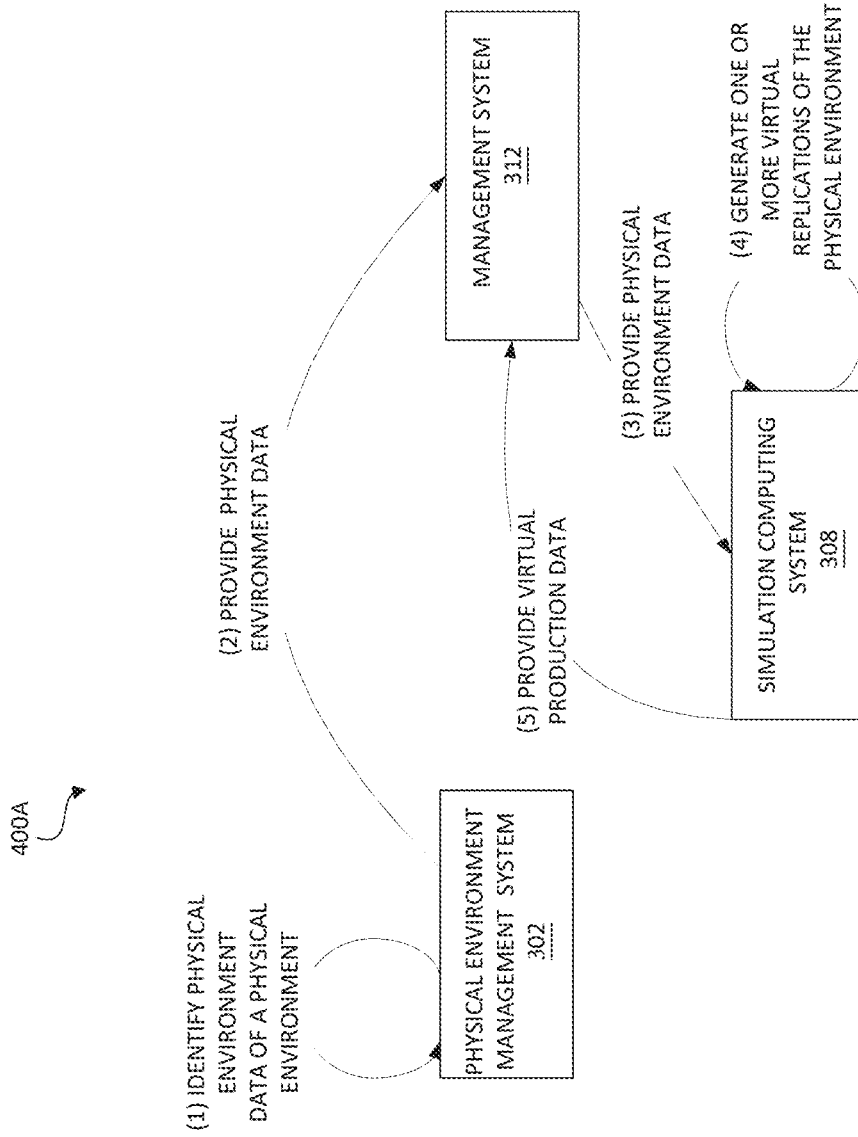

FIG. 4A

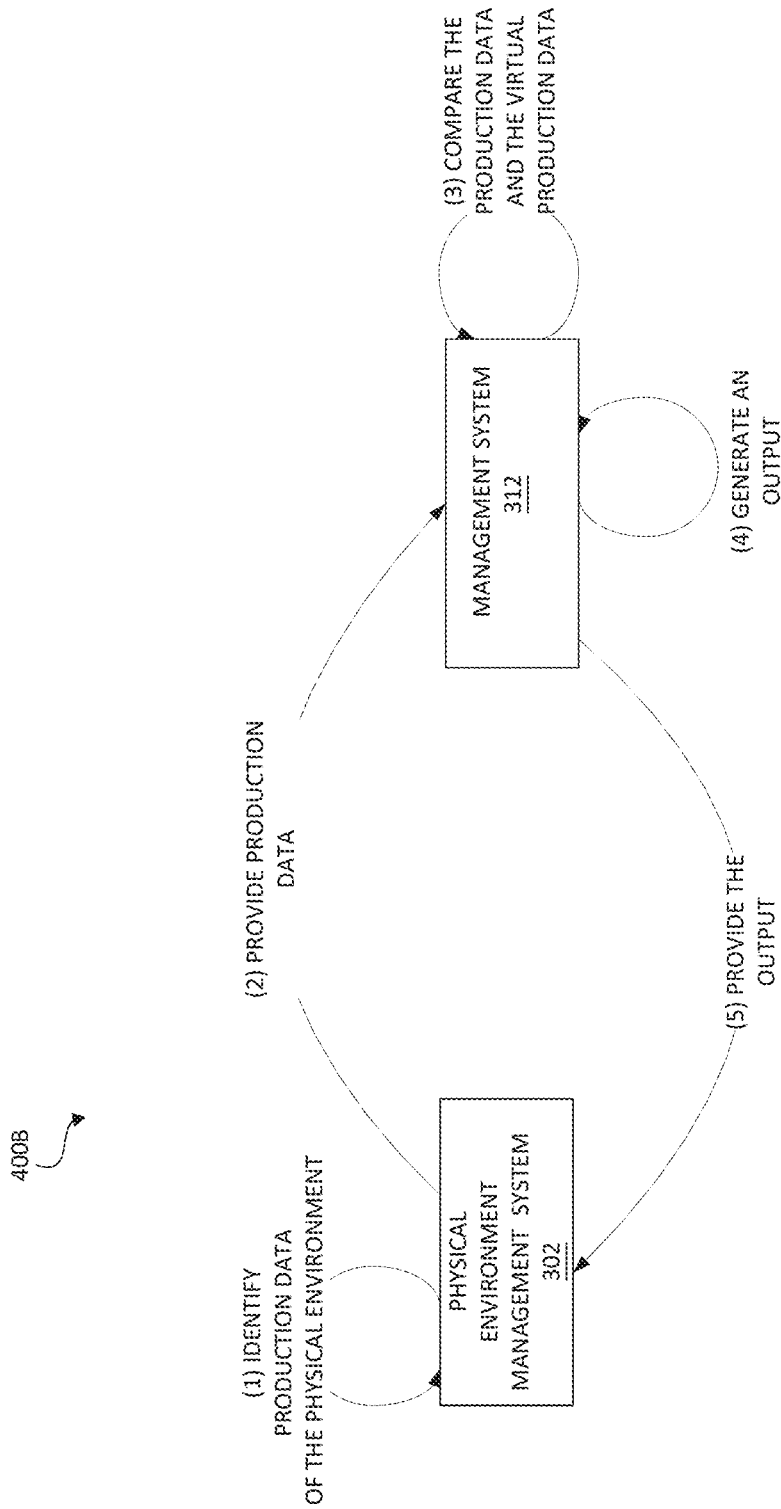

FIG. 4B

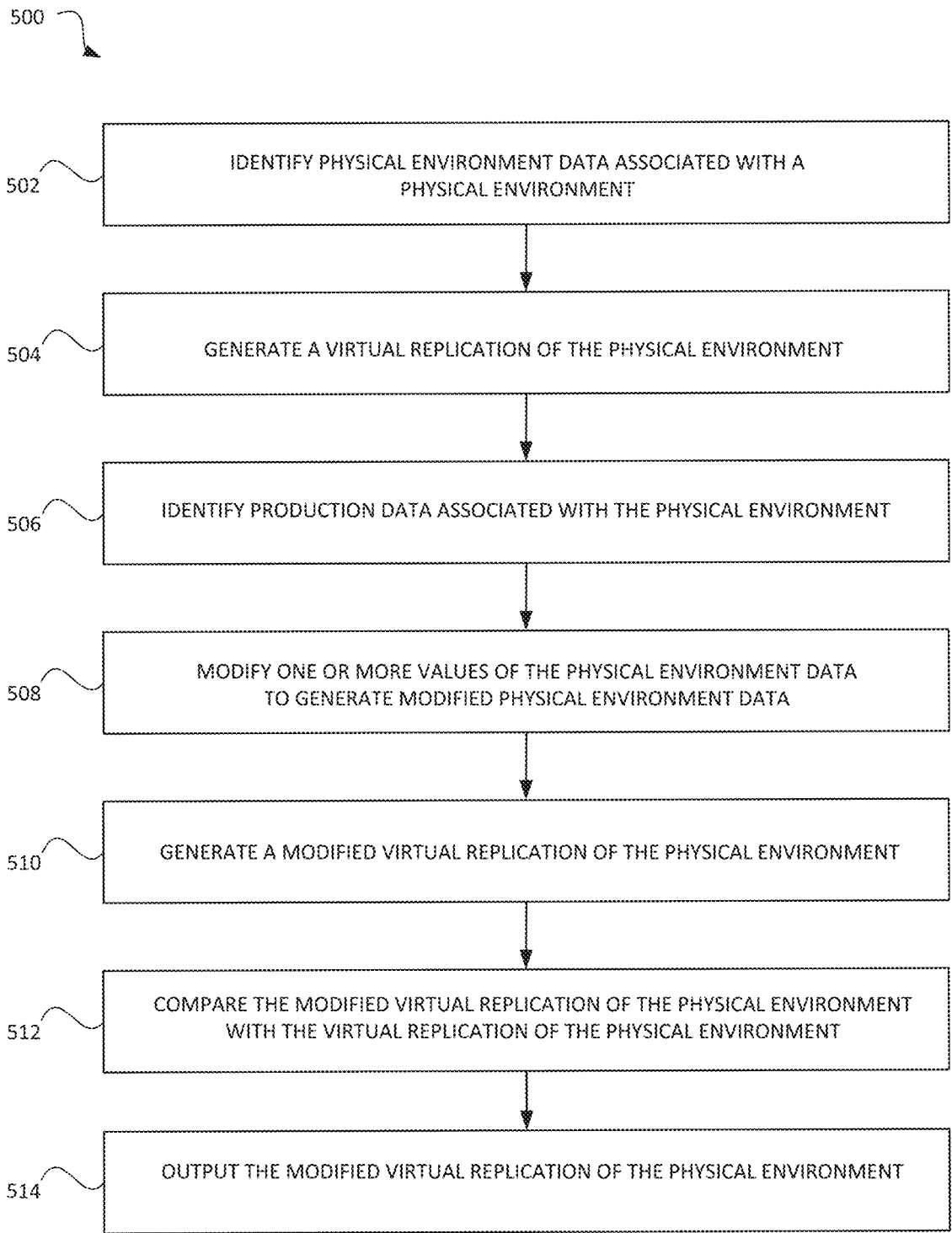

FIG. 5

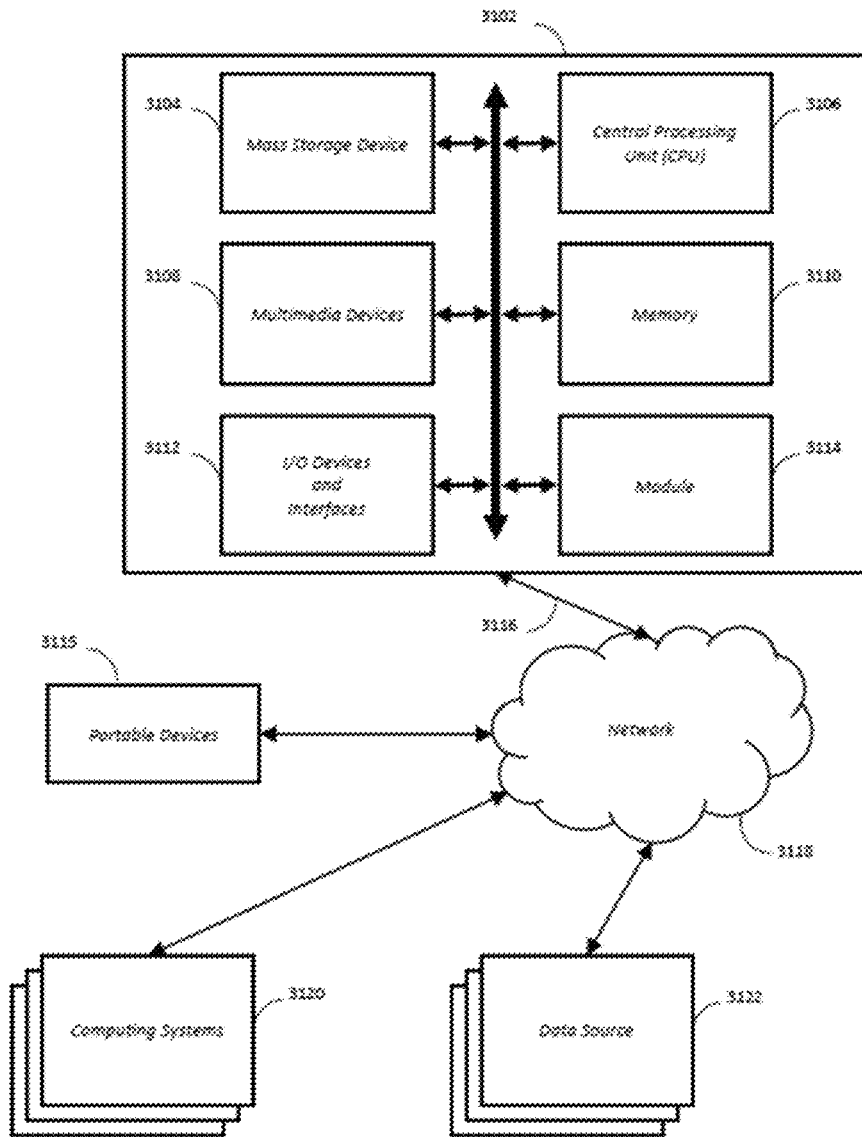

FIG. 6

EXECUTION OF MACHINES BASED ON PERFORMANCE DATA

RELATED APPLICATIONS

This application is a continuation-in-part of U.S. patent application Ser. No. 18/160,046, filed Jan. 26, 2023, entitled “SYSTEMS, METHODS, AND DEVICES FOR LOCATION-BASED PRODUCTION OPTIMIZATION,” the entire contents of which is hereby incorporated by reference herein.

FIELD

This present disclosure relates to systems, methods, and devices for execution of machines based on performance data, such as, in certain embodiments, systems and methods for determining and implementing an order schedule, a layout of a physical environment, and/or a worker schedule based at least in part on locations of work centers and distribution points.

BACKGROUND

Beverages may be prepared using different preparation methodologies or processes.

BRIEF DESCRIPTION OF THE DRAWINGS

Various embodiments are depicted in the accompanying drawings for illustrative purposes and should in no way be interpreted as limiting the scope of the embodiments. Furthermore, various features of different disclosed embodiments can be combined to form additional embodiments, which are part of this disclosure.

FIGS. 1A, 1B, and 1C illustrates various embodiments of systems for implementing location-based production optimization.

FIG. 1D illustrates an embodiment of a label and an item container of the systems for implementing location-based production optimization of FIGS. 1A-1C.

FIG. 2A illustrated a schematic of a layout of a physical environment.

FIG. 2B illustrates a schematic of production channels of the physical environment layout of FIG. 2A.

FIG. 2C illustrates a schematic of a work station of the physical environment of FIGS. 2A and 2B.

FIG. 3 illustrates a block diagram depicting an illustrative environment in which a management system can manage one or more virtual replications of a physical environment.

FIGS. 4A and 4B illustrate flow diagrams depicting example interactions for generating the virtual replications of the physical environment.

FIG. 5 illustrates a flow chart depicting an illustrative routine for generating the virtual replications of the physical environment and generating an output.

FIG. 6 illustrates a block diagram illustrating an embodiment of a computer hardware system configured to run software for implementing one or more embodiments of the system, methods, and devices disclosed herein.

DETAILED DESCRIPTION

Although several embodiments, examples, and illustrations are disclosed below, it will be understood by those of ordinary skill in the art that the system, methods, and devices described herein extend beyond the specifically disclosed

embodiments, examples, and illustrations and includes other uses of the system, methods, and devices and obvious modifications and equivalents thereof. Embodiments of the disclosure are described with reference to the accompanying figures, wherein like numerals refer to like elements throughout. The terminology used in the description presented herein is not intended to be interpreted in any limited or restrictive manner simply because it is being used in conjunction with a detailed description of certain specific embodiments of the disclosure. In addition, embodiments of the disclosure can comprise several novel features and no single feature is solely responsible for its desirable attributes or is essential to practicing the system, methods, and devices herein described.

At high throughput production facilities, such as nationwide cafés or coffee retailers, small changes in the manner in which objects (e.g., item(s), device(s), article(s), physical component(s), etc.) are prepared can significantly improve efficiency and throughput. For example, the manner in which item(s) are prepared can include the order in which the item(s) are prepared, the work center(s) used to prepare the item(s), the distribution point(s) used to distribute the item(s), the distances between work center(s) associated with the item(s), the distance(s) between the work centers and distribution point(s) associated with the item(s), different throughput stream(s), the worker(s) assigned to prepare the item(s) (e.g., automated or human workers), etc. A change in throughput, in turn, can increase the efficiency of the systems and decrease wait times for users. For example, the change in throughput can modify the efficiency in which orders are prepared and delivered. The change in throughput can also modify item pricing and worker scheduling, among other considerations. While the present disclosure references items, the system, methods, and devices herein described may be implemented with respect to any objects.

Systems may modify the manner in which products are prepared based on outputs from production tracking systems. However, current production tracking systems require workers to manually indicate when production of an item and/or an order is complete. Manual indication is unreliable and is usually done by workers for an incomplete percent of items/orders making it difficult to determine accurate production times and production efficiency. Additionally, production tracking systems do not account for distances between work centers and distribution points or different throughput streams. Without accurate production times and additional production information, it can be difficult to determine which factors (e.g., a layout of a physical environment, worker schedule, etc.) affect production time, production efficiency, or throughput.

Additionally, as the manners in which workers or systems determine and track production of an item and/or completion of an order may be diverse and large in number, traditional systems utilizing manual determinations may be unable to manually identify particular factors to modify in an efficient manner to improve the efficiency of the production of an item and/or completion of an order. Further, it would be inefficient and time consuming for the system to manually compare multiple sets of production time for each item and/or order and/or for the system to make determinations based on items and/or orders associated with a particular worker (e.g., a robot). Additionally, when the manual process is completed, the factors may have changed such that the production data may no longer be relevant. Therefore, such traditional systems may lead to inaccuracies. Further,

the use of such traditional systems can increase memory demands and processing usage by computing devices due to the iterative process.

Typically, such traditional systems may be unable to dynamically analyze production channels to determine production data associated with the production channels and determine performance data for machines associated with machines of the production channels. Further, such traditional systems may be unable to instruct a machine to execute an operation to perform an operation based on the performance data.

In accordance with several embodiments, the systems described herein advantageously can be used to determine production times of items and/or orders in a consistent, accurate manner. The systems can include scanners, RFID tags, and/or any other sensors to track production of items and/or orders from when a user places an order to when the items and/or order are placed at a distribution point. Therefore, the systems can normalize how the production of the items and/or the orders is determined and monitored such that accurate performance data can be determined. In some cases, the system can provide input data generated by machines of a production channel to a machine learning model to determine performance data. The systems may utilize the performance data to determine how to instruct machines to execute operations (e.g., instruct other machines to perform other operations (e.g., complete other orders), the same machine to complete other orders, generate and/or provide a schedule or layout, etc.).

The systems can use scanners, RFID tags, and/or any other sensors to determine (e.g., monitor, track, etc.) or identify locations of workers throughout the production of items and/or orders. The systems can use locations of various scanners or other input/tracking devices placed at distribution points and/or work centers used to produce items as input data for determining performance data (e.g., production efficiency and/or optimization of production efficiency). By utilizing the systems in such a manner, the efficiency (e.g., computing system efficiency), throughput, etc. may be improved.

FIG. 1A shows a system **100** for implementing location-based production optimization. The system **100** may include a point-of-sale system **102**, a controller **104** (referred to herein as production controller **104**), a label **108**, one or more physical hardware devices (e.g., one or more printers **106** (which can also be referred to herein as “label printers” when configured to print a label), one or more scanners **110**, etc.), a router **112**, a data processor **114**, a data analysis platform **116** and/or a user device **118**. For example, the system may include a first hardware device (e.g., printer **106**), a second hardware device (e.g., a first scanner **110**), and a third hardware device (e.g., a second scanner **110**). Each of the one or more hardware devices may be located at a particular location within a physical environment. The point-of-sale system **102** may receive object data (e.g. orders, requests, queries, etc. indicating one or more objects), calculate a price or cost of orders, receive payments and/or any other common functions of a point-of-sale system. The point-of-sale system **102** may receive the object data from computing devices. In some cases, the object data may include order data and the point-of-sale system **102** may receive an order by receiving order data indicative of the order and/or may generate order data indicative of the order. The point-of-sale system **102** may transmit the object data (e.g., orders, the order data, and/or any information related to the orders) to the production controller **104**. While

the present disclosure references orders, the system, methods, and devices herein described may be implemented with respect to object data.

The production controller **104** may receive the object data. The production controller **104** may schedule or sequence orders. The production controller **104** may use artificial intelligence (AI) and/or machine learning (ML) to determine performance data (e.g., an order schedule (e.g., an order sequence), a layout, machine analytics, item production analytics, etc.) based on the input data. For example, the production controller **104** may determine an optimized order schedule based on the input data. For example, the production controller **104** may train a machine learning model using training data (e.g., one or more orders, input data, and an optimized order schedule) to output performance data indicative of an order schedule based on the orders and the input data. In some embodiments, the machine learning model may output performance data and the production controller **104** may generate an order schedule based on the performance data. In certain embodiments, the input data may include and/or may be indicative of a physical layout of a physical environment (e.g., a physical layout of machines within a physical environment), a machine status, a location of a physical environment, an order history, a historic efficiency, a current efficiency, a worker schedule, worker efficiency, item production time history, order production time history, a current date/time, a current schedule of orders, a current production stage of each item of current orders, an order origin, a distribution point, a distribution point location, and/or any other information described herein. In certain embodiments, the input data may include any data calculated by the data processor **114** and/or the data analysis platform **116**. In certain embodiments, the input data may include any analysis performed by the data processor **114** and/or the data analysis platform **116**.

In certain embodiments, the production controller **104** may transmit order data (e.g., orders and/or the optimized order schedule) to the printer **106**, the data processor **114**, and/or the data analysis platform **116**. The production controller **104** can transmit the orders and/or the order schedule to the data processor **114** and/or the data analysis platform **116** via a Webhook, an application programming interface (API), and/or any other system for transmitting data or information between devices. In certain embodiments, the data processor **114** and/or the data analysis platform **116** may retrieve the orders and/or the order schedule from the production controller **104**. The data processor **114** and/or the data analysis platform **116** may retrieve the orders and/or the order schedule from the production controller **104** via a Webhook, an application programming interface (API), and/or any other system for transmitting data or information between devices.

Based on the order schedule, the production controller **104** may transmit instructions to the printer **106** to print a label **108**. The printer **106** may physically output (e.g., print, display, cause display of, etc.) a label **108** based on the order data. For example, the printer **106** may print a label **108** for each order and/or each item in an order based on the order data. For example, the instructions may cause the printer **106** to print the label **108**. The printer **106** may transmit to the production controller **104** and/or the data processor **114** first time data indicative of a time/date of when a label **108** is printed by the printer **106**. For example, the printer **106** may transmit first time data indicative of an output time (e.g., a printing time) of the label by the printer **106**. In certain embodiments, the production controller **104** may use the orders and/or the order schedule to automatically determine

when to cause the printer **106** to print a label **108** for each order or each item in an order. For example, the production controller **104** may schedule instructions to be sent to the printer **106** such that the printer receives different subsets of the instructions at different time periods and prints a corresponding label at each time period. In another example, the instructions may cause the printer **106** to print different subsets of the instructions at different time periods. In certain embodiments, the production controller **104** may instruct the printer **106** to print a label **108** for each item in a first order before printing a label **108** for a second order.

In certain embodiments, the printer **106** may print item information **108C**, a first machine readable code **108A**, a second machine readable code **108B**, and/or any other information on an item container **109**. In some embodiments, the printer **106** may transmit object data (e.g., item data, item information **108C**, information contained in the first machine readable code **108A**, information contained in the second machine readable code **108B**, and/or any other information) to a processor or a memory embedded in the item container **109** and/or a worker computing device. For example, the worker computing device may be a computing device of a robot, a computing device of a human, etc. The printer **106** may transmit the information to the processor via Bluetooth, NFC, Wi-Fi, ZigBee, infrared, and/or any other communication protocol.

The label **108**, may include a first machine readable code **108A** as depicted in FIG. 1D. The first machine readable code **108A** may be a barcode, a QR code, and/or any other machine-readable optical label and/or other machine-readable codes, such as, for example, physical patterns, magnetic strips, radio-frequency identification (RFID), or electrical circuits. In certain embodiments, the label **108** may include a second machine readable code **108B** as depicted in FIG. 1D. The second machine readable code **108B** may be a barcode, a QR code, and/or any other machine-readable optical label and/or other machine-readable codes. The first machine readable code **108A** and second machine readable code **108B** may be scanned or read by a computing device. For example, the second machine readable code **108B** may be scanned or read by a user via a user computing device. The second machine readable code **108B** may automatically direct or redirect a user to a survey, order information (e.g., a time of order, time to complete order, location of a physical environment, pick-up time of order, etc.), user rewards, and/or any other information related to the user, the item, or the order. The survey, order information, user rewards, and/or other information related to the user, the item, or the order may be customized based on the user or a user profile associated with the item or the order.

The label **108** may include item information **108C** as depicted in FIG. 1D. The item information **108C** may include a number of items in an order associated with the label **108**, an item number, an order number, an order name, an item identifier, components of the item, an order date and/or time, a store number, an order origin, and/or an order fulfillment method. The item identifier may be a Stock Keeping Unit (SKU) associated with the item, an item name, an abbreviated item name, and/or any other item identifier. The order origin may indicate where the point-of-sale system **102** received the order from a computing device (e.g., via an application (e.g., a third-party application), a website, etc.). The order fulfillment method may indicate a distribution point or how the order will be delivered to or picked up by a user (i.e., delivery, pick up, counter pick up, etc.). The

first machine readable code **108A** and/or the second machine readable code **108B** may contain all or a portion of the item information **108C**.

The first machine readable code **108A** may be optically scanned or read by the scanner **110** (e.g., actively or passively). In certain embodiments, the system **100** can include a plurality of scanners **110**. All or a portion of the plurality of scanners **110** may include one or more image sensors to optically scan or read the first machine readable code **108A**. The system **100** can include 1, 2, 3, 4, 5, 6, 7, 8, 9, 10, and/or any other number of scanners **110** including more than 10 scanners. In certain embodiments, the system **100** can include between 1 and 10 scanners **110**. In certain embodiments, the system **100** can include between 2 and 9 scanners **110**. In certain embodiments, the system **100** can include between 3 and 8 scanners **110**. In certain embodiments, the system **100** can include between 4 and 7 scanners **110**. In certain embodiments, the system **100** can include more than 10 scanners **110**.

The scanner **110** may be associated with a location of a physical environment where the scanner **110** is physically located. The location may be at the point-of-sale system **102**, a register, a work center, the printer **106**, a pick-up counter, a drive through window or counter, an online order pick-up counter, a delivery pick-up counter, any other distribution point, and/or a point along the production line of order. In certain embodiments, the location of the scanner **110** may be a GPS location of the scanner **110**.

A user and/or a worker can place the label **108** on a corresponding item container **109** as depicted in FIG. 1D. The item container **109** may be a cup, beverage holder, food packaging, and/or any other item container **109**. In certain embodiments, the printer **106** may print the label **108** and the printer **106**, or a separate component of the system **100** (e.g., a robotic device), may automatically place the label **108** on the corresponding item container **109**.

In certain embodiments, the item container **109** may include container identification information **109A** as depicted in FIG. 1D. In certain embodiments, the container identification information **109A** may include a machine readable code. The user and/or the worker may use the scanner **110** to associate the label **108** and/or the item information **108C** with the container identification information **109A**. In these embodiments, instead of scanning the label **108** as described herein, the user and/or the worker may scan the container identification information **109A**. Based on scanning one or more of at least a portion of the label **108** and/or the container identification information **109A**, the scanner **110** may associate the at least a portion of the label **108** and the container identification information **109A**. The scanner **110** may generate association information linking the at least a portion of the label **108** and the container identification information **109A** and may store the association information in a local or remote data store. In some embodiments, the scanner **110**, or a separate component of the system **100**, may generate the association information and store the association information in a data store accessible by all or a portion of the components of the system **100**.

In certain embodiments, the user and/or the worker may place the first machine readable code **108A** of a label **108** in front of the scanner **110** so the scanner **110** can scan or read the first machine readable code **108A** when the user and/or the worker completes production of the item associated with the label **108**. In some embodiments, the system **100** may

include a robotic device. The system **100** may cause the robotic device to move the first machine readable code **108A** in front of the scanner **110**.

When the scanner **110** scans or reads the first machine readable code **108A** of a label **108**, the scanner **110** can obtain and/or generate production data **111** based on the first machine readable code **108A**. In some embodiments, the scanner **110** may route data corresponding to the first machine readable code **108A** to a computing device, and the computing device may generate the production data. The production data **111** may include an indication that the scanner **110** scanned or read the first machine readable code **108A**, an indication that production of the item associated with label **108** is complete, time data indicative of a date/time when the scanner **110** scanned or read the first machine readable code **108A** (e.g., a scanning time, a scan time), and/or an indication of the user or robotic device that placed the first machine readable code **108A** in front of the scanner **110** (i.e., the user or worker that produced or made the item). In certain embodiments, if the item is the only item in an order and/or a last item (e.g., production of all other items in an order is complete or first machine readable codes **108A** of labels **108** of all other items in the order have previously been scanned) in the order, the production data **111** may include an indication that production of the order is complete.

The scanner **110**, or a separate component of the system **100**, may transmit the production data **111** to the data router **112**. In certain arrangements, the scanner **110** automatically transmits production data **111** to the data router **112** (e.g., in response to scanning or reading the first machine readable code **108A**).

The data router **112** may receive the production data **111** from the scanner **110**. In certain embodiments, the data router **112** may be any computing device such as a desktop, laptop or tablet computer, personal computer, wearable computer, server, personal digital assistant (PDA), hybrid PDA/mobile phone, mobile phone, electronic book reader, set-top box, voice command device, camera, digital media player, a bare metal computer system, a bare machine, and the like. In certain embodiments, the data router **112** may be an internet of things (IoT) data router or a server. In certain embodiments, the data router **112** may be part of or embedded in the scanner **110**.

In certain embodiments, the data router **112**, or a separate component, may generate the production data **111** based on data obtained from a communication device (e.g., an RFID tag **109B** depicted in FIG. 1D) coupled to or embedded in an item container **109**. For example, the data router **112** may generate the production data **111** based on data obtained from the communication device in addition or instead of receiving the production data **111** from the scanner **110**. In these embodiments, the data obtained from the communication device can include an identifier of the item container **109**, the item, and/or the order. The data router may generate production data **111** identifying a location of the item container **109**, a stage of production of the item associated with the item container **109**, a date/time when each stage of production was completed, and/or any other information associated with the production of the item based on the data obtained from the communication device. The communication device may transmit the data to the data router **112** in real time, or the RFID tag **109B** can transmit the data to the data router **112** when production of the item is complete. For example, an RFID reader may read an RFID tag **109B** and transmit data identifying the RFID tag, the corresponding item container **109**, the item, and/or the order to the data

router **112**. In some embodiments, the data router **112**, or a separate component, may receive the production data **111** from a communication device.

In certain embodiments, the scanner **110** may transmit a hardware device identifier **113** (referred to herein as scanner identifier **113**) (e.g., a numerical, alphabetical, alphanumeric, symbolical, etc. identifier) to the data router **112**. For example, the scanner **110** may transmit a scanner identifier **113** with the production data **111** to the data router **112** or separate from the transmission of the production data **111** to the data router **112**. In certain embodiments, the data router **112** may include a local or remote data store (e.g., memory) configured to store scanner identifiers **113** associated with all or a portion of the scanners **110** in the system **100**. For example, a computing device may upload the scanner identifiers **113** to the data store and/or may link particular scanner identifiers **113** to particular scanners within the data store (e.g., may link a scanner identifier to an address associated with the scanner). In certain embodiments, the scanner **110** may communicate with or be paired with the data router **112** via Bluetooth, NFC, Wi-Fi, ZigBee, infrared, and/or any other communication protocol. The scanner **110** may request or instruct the data router **112**, a user, and/or a worker to assign the scanner **110** to a location in a physical environment (i.e., a work center, a distribution point, etc.).

In certain embodiments, the scanner **110** may include the scanner identifier **113** (e.g., printed or otherwise displayed on a portion of the scanner **110**), and a user computing device may upload the scanner identifier **113** to the data store. In certain embodiments, the data router **112** may automatically determine which scanner **110** the data router **112** received the production data **111** from. The scanner identifier **113** may identify a model of the scanner **110**, an IP address of the scanner **110**, a scanner **110** number, a scanner **110** name and/or any other information associated with the scanner **110**. In certain embodiments, the scanner identifier **113** may indicate or identify a location of the scanner **110**. In certain embodiments, the scanner identifier **113** may be a numerical, alphabetical, or alpha-numeric string. The location of the scanner may be a GPS location and/or a known location of the scanner **110**. For example, the scanner identifier **113** may identify GPS coordinates associated with the scanner **110**. The scanner **110** may include a location sensor that provides location data identifying a location of the scanner **110**, and the scanner **110** may include the location data within the scanner identifier **113**.

In certain embodiments, a display **119** (e.g., of a computing device) may display the production data **111** and/or the scanner identifier **113** to the user. The scanner **110** and/or the data router **112** may provide instructions to a computing device that cause the computing device to display the production data **111** and/or the scanner identifier **113** via a display **119** of the computing device. In certain embodiments, the display may be part of the data router **112**, and/or the user device **118**. The display **119** may display the production data **111** and/or the scanner identifier **113** for each item and/or order to the user. The display **119** may display the production data **111** and/or the scanner identifier **113** for each item and/or order to the user based on when each item was scanned, when each order was completed, when each order was received and/or any other sequence.

The data router **112** may transmit the production data **111**, scanner identifier **113** associated with the production data **111**, the item information **108C**, and/or any other data to the data processor **114**. The data processor **114** may be a server, an array of servers, a cloud computing platform, and/or any other computing device. The data processor **114** may process

and/or analyze any data or information received from the production controller 104, and/or the data router 112 to calculate any data and/or perform any of the analysis described herein. The data processor 114 may include a data store (e.g., memory). The data store may include a database of data or information received by the data processor 114, all or a portion of data calculated by the data processor 114, and/or all or a portion of analysis performed by the data processor 114. The data store or memory may be configured to store computer-executable instructions. The data store or memory may be in communication with at least one process configured to execute the computer-executable instructions.

A user device 118 may retrieve (e.g., download) data stored in the data store. The user device 118 may be any computing device such as a desktop, laptop or tablet computer, personal computer, wearable computer, server, personal digital assistant (PDA), hybrid PDA/mobile phone, mobile phone, electronic book reader, set-top box, voice command device, camera, digital media player, and the like.

In certain embodiments, the data stored in the database may include a file format. The file format may be comma-separated value file (.csv), data file (.dat), database file (.db or .dbf), log file (.log), Microsoft Access database file (.mdb), save file (.sav), SQL database file (.sql), tarball file archive (.tar), XML file (.xml), and/or any other file format.

The user device 118 may transmit the retrieved data to the data analysis platform 116. The data analysis platform 116 may be a server, an array of servers, a cloud computing platform, and/or any other computing device. The data analysis platform 116 may process and/or analyze data received from the user device 118, and/or the production controller 104 to calculate any data and/or perform any of the analysis or operations described herein. The data analysis platform 116 may include a data store (e.g., memory). The data store may include a database of data or information received by the data analysis platform 116, all or a portion of data calculated by the data analysis platform 116, and/or all or a portion of the results of the analysis performed by the data analysis platform 116.

FIG. 1B shows another system 100B for implementing location-based production optimization. Common features between the system 100B for implementing location-based production optimization and the system 100 for implementing location-based production optimization will not be described again but are incorporated here in their entirety.

The system 100B may include a distribution point device 120. The distribution point device 120 may be a desktop, laptop or tablet computer, personal computer, wearable computer, server, personal digital assistant (PDA), hybrid PDA/mobile phone, mobile phone, electronic book reader, set-top box, voice command device, camera, digital media player, and the like. The distribution point device 120 may transmit data to the production controller 104 and/or receive data from the production controller 104. The distribution point device 120B can receive orders and/or the order schedule from the production controller 104. The distribution point device 120 may receive the production data 111, the item information 108C, all or a portion of the data calculated by the data processor 114 and/or the data analysis platform 116, and/or all or a portion of the results of the analysis performed by the data analysis platform 116.

In certain embodiments, the display 119 may be part of the distribution point device 120. The distribution point device 120 may cause display, via the display 119, of one or more of the orders, the order schedule, the production data 111, the item information 108C, all or a portion of data calculated by the data processor 114 and/or the data analysis

platform 116, and/or all or a portion of the results of the analysis performed by the data analysis platform 116. In certain embodiments, the distribution point device 120 may cause display, via the display 119, of data associated with at least one of the orders. For example, the data may identify a date/time when an order was received by the point-of-sale system 102, a date/time when the printer 106 printed a label 108 associated with the order and/or an item of the order, a current stage of the order and/or each item of the order, an estimated production completion time of the order and/or each item of the order, a date/time when production of each item and/or order was completed, the worker that produced or completed production of each item and/or order, the location of the scanner 110 that scanned the first machine readable code 108A of the label 108 associated with each item of the order, and/or any other data or information described herein.

In certain embodiments, a user may edit or update orders and/or the order schedule via the distribution point device 120. In certain embodiments, the user, via the distribution point device 120, may edit or update any data displayed by the distribution point device 120. For example, if production of an item and/or an order is complete, but the distribution point device 120 does not indicate that production is complete, the user can mark the production of the item and/or the order as complete via an input to the distribution point device 120. In another example, if a scanner 110 moves from a first location to a second location, the user may update a location associated with the scanner 110 from the first location to the second location via an input to the distribution point device 120. For example, the user may provide an input to the distribution point device 120 identifying a scanner identifier 113 and an updated location identifier (e.g., updated GPS coordinates). In this example, the distribution point device 120 may transmit an indication to the production controller 104 that the scanner 110 is located at the second location.

The data router 112 of system 100B may transmit the production data 111, the scanner identifier 113 associated with the production data 111, the item information 108C, and/or any other data to the data processor 114 and the production controller 104.

As shown in FIG. 1B, the user device 118 of system 100B may retrieve or download data from the data analysis platform 116 of system 100B.

FIG. 1C shows a system 100C for implementing location-based production optimization. Common features between the system 100C for implementing location-based production optimization and the systems 100, 100B for implementing location-based production optimization will not be described again but are incorporated here in their entirety. The system 100C may not include a data processor 114. The data router 112 of system 100C may transmit the production data 111, scanner identifier 113 associated with the production data 111, the item information 108C, and/or any other data to the production controller 104.

In certain embodiments of systems 100, 100B, 100C, the production controller 104, the data processor 114, and/or the data analysis platform 116 may transmit user order information to a user computing device. The user order information may include a date/time when an order of the user was received, a current stage of the order and/or each item of the order, an estimated production completion time of the order and/or each item of the order, a date/time when production of each item and/or order was completed, and/or any other information associated with the order of the user.

In certain embodiments, the production controller **104** of systems **100**, **100B**, **100C** may communicate with one or more physical machines (referred to hereinafter as machines or as production machines) **202A**, described further below with reference to FIG. 2C. The production controller **104** may receive data from the one or more production machines **202A**. The production controller **104** may be able to track an item at each production stage of the item.

The scanner **110** of systems **100**, **100B**, **100C** may have certain advantages over manual entry of indications when production of items and/or orders are complete, such as an increased success rate at which users and/or workers indicate when production of items or orders are complete, an increased speed at which at which users and/or workers may indicate when production of items or orders are complete, an increased ease, etc. However, in certain embodiments, systems **100**, **100B**, **100C** may include one or more stations for partial or full manual entry of indication when production of items and/or orders are complete (e.g., a touch pad for manual entry). In certain embodiments, systems **100**, **100B**, **100C** may include a combination of scanners **110** and stations for partial or full manual entry. In certain embodiments, systems **100**, **100B**, **100C** may include a station for partial or full manual entry at each location of a scanner **110**. FIG. 2A shows a schematic of an example layout of a physical environment **200**. The physical environment may include work centers **202** and distribution points **204**. The work centers **202** may be any location in a physical environment **200** where a worker can produce or cause production of items, perform one or more steps for production of an item, etc. For example, a machine at a first work center can implement one or more first steps for production of the item (e.g., an espresso machine can pull one or more espresso shots) and a machine at a second work center can implement one or more second steps for production of the item (e.g., an automated syrup dispenser can dispense an amount of syrup to be added to the one or more espresso shots). In certain embodiments, the work centers **202** may be any location in the physical environment **200** where orders or a portion of a particular order can be received and/or fulfilled. In certain embodiments, the work centers **202** may be any location in the physical environment **200** with a printer **106**.

As shown in FIG. 2C, a work center **202** may include one or more production machines **202A**. The one or more production machines **202A** can include a coffee maker, an oven, a microwave, an item component indication system, devices for distributing or dispensing ingredients like syrups, dry ingredients, ice, milk, or other beverages components, devices for automatic distribution of beverages or beverage components, an espresso dispensing device, a milk frothing device, and/or any other beverage or food production machines or devices. The one or more production machines **202A** may transmit data to the production controller **104** and/or any other components of systems **100**, **100B**, **100C** via a wired or wireless connection. The data may be an indication that a beverage, ingredient, or component was dispensed, an indication that a production machine **202A** is in use, an indication that a production machine **202A** is unavailable, an indication that a production machine **202A** is out of order, an indication that a production machine **202A** is available, an indication that a production machine **202A** is ready for use, an indication of when the production machine **202A** will be ready for use, an indication of an item being produced by the production machine **202A**, an indication of a user and/or worker working at a

production machine **202A**, and/or any other data associated with the use of a production machine **202A**.

The distribution points **204** may be any location in a physical environment **200** where items and/or orders are distributed to users. For example, the distribution points **204** may be a drive thru counter, a pick up counter, an online order pick-up counter, a delivery order pick-up counter, and/or any other location in the physical environment **200** where users can pick-up or receive their order. In certain embodiments, each distribution point **204** in a physical environment **200** can include a scanner **110**. Each scanner **110** may be associated with a distribution point **204** such that systems **100**, **100B**, **100C** may know where each scanner **110** and/or distribution point **204** is in the physical environment **200**. In certain embodiments, systems **100**, **100B**, **100C** can obtain and/or store data identifying a distance from all or a portion of the distribution points **204** and scanners **110** to all or a portion of the work centers **202**. Further, the systems **100**, **100B**, **100C** can obtain and/or store data identifying a distance between all or a portion of the work centers **202**.

FIG. 2B shows a schematic of the example layout of a physical environment **200** with production channels **206**. The physical environment **200** may include the production channels **206**. For example, the production channels **206** may be routes (e.g., navigational routes, physical routes, etc.), tracks, trails, paths, channels, etc. within (e.g., through) the physical environment. All or a portion of the production channels **206** may include a channel start **206A** and a channel end **206B**. For example, the channel start **206A** may be a route start and the channel end **206B** may be a route end. All or a portion of the production channels **206** may include one or more physical machines (e.g., production machines) distributed across the production channel. In some cases, the one or more physical machines may be one or more computing systems. A production channel **206** may be a channel including a channel start **206A**, a channel end **206B**, and a plurality of machines. In another example, a production channel **206** may be a channel from a channel start **206A** to a channel end **206B** and a plurality of machines may be located (e.g., interspersed) between the channel start **206A** and the channel end **206B**. In some cases, different production channels **206** may include different machines. For example, a first production channel may include a first type of coffee maker (e.g., a drip coffee maker) and a second production channel may include a second type of coffee maker (e.g., a French press coffee maker). In some cases, different production channels **206** may include the same machines. For example, a first production channel and a second production channel may each include a first type of coffee maker (e.g., a drip coffee maker). Further, the first production channel and the second production channel may include the same or different machines. The channel start **206A** may be any work center **202** or location of a printer **106**. The channel end **206B** may be any distribution point **204**. The production channels **206** may be a path the item takes from when a worker takes a label **108** for the item at a work center **202** to when the label **108** is scanned by a scanner **110** at a distribution point **204**.

In certain embodiments, production channels **206** may include one or more intermediate production stages. The intermediate production stages may be any work center **202** other than the channel start **206A** used to produce an item. For example, a worker may take a label **108** for an item at a first work center **202** (i.e., the channel start **206A**) and the worker may produce a portion of the item at the first work center **202**. The item may require the worker also produce a

13

portion of the item at a second work center **202** (i.e., an intermediate production stage) before production of the item is complete and the label **108** is scanned by a scanner **110** at a distribution point **204** (i.e., the channel end **206B**).

In certain embodiments, performance data (e.g., item production analytics, diagnostics, observations, etc.) may be calculated and/or determined (e.g., by the production controller **104**, the data processor **114**, and/or the data analysis platform **116**). In some cases, a modelling system (e.g., a simulation system or platform) may model a physical environment based on one or more modelling parameters and the modelling system, or a separate system, may determine performance data for each modelled physical environment and one or more modelling parameters. The modelling parameters may include physical environment data, and the physical environment data may identify a configuration of the physical environment. For example, the configuration of the physical environment may include a physical environment layout, a physical environment design, a worker allocation, a machine allocation, a machine layout, physical environment operation parameters, ordering parameters, or any other data associated with the configuration of the physical environment. The physical environment data may identify a physical layout of the physical environment. For example, the physical environment data may identify the placement, type, and quantity of tables, chairs, registers, machines, products, etc. Further, the physical environment data may identify whether the physical environment includes a drive-thru component and/or a walk-in component. The physical environment data may also identify the workers allocated to the physical environment. For example, the physical environment data may identify the number, role, and/or type (e.g., management, years, or levels of experience, etc.) of workers that are allocated to the physical environment. Further, the physical environment data may identify how orders are processed and handled by the workers with the physical environment. For example, whether orders are linked to the first available workers, whether certain orders are linked together, etc. The physical environment data may further identify menu options. For example, the physical environment data may identify food and/or drink options that are available for purchase at a particular physical environment (e.g., some physical environments may not offer particular products such as cold brew coffee).

Based on the performance data, the modelling system can recommend particular physical environment data for a particular physical environment. For example, the modelling system can recommend a particular layout of machines, a particular distribution of work centers and/or distribution points, a particular allocation of workers, etc.

In one example, the performance data may include an item production time. The item production time may be calculated using Equation 1 below:

$$\text{Item Production Time} = (\text{Item Delivered to Distribution Point}_{\text{Time}} - \text{Item Label Pulled}_{\text{Time}}) \quad \text{Equation 1}$$

The item production time may be a time for an item to be produced from when a label **108** for the item is taken by a worker at a work center **202** (e.g., a channel start **206A**) (Item Label Pulled_{Time}), to a time when an item is placed at a distribution point **204** and/or the label **108** is scanned by a scanner **110** at a distribution point **204** (e.g., the channel end **206B**) (Item Delivered to Distribution Point_{Time}).

In certain embodiments, a system may determine intermediate item production times (e.g., using Equation 1). The intermediate item production time may be a time for each

14

portion of the item to be produced by a worker. In these embodiments, if the portion of the item is produced at an intermediate production stage, the Item Label Pulled_{Time} may be a time when the worker and/or the item get to or arrive at the intermediate production stage. If a worker must produce a second portion of the item at a second intermediate production stage after the intermediate production stage, the Item Delivered to Distribution Point_{Time} for the intermediate item production time associated with the first intermediate production stage may be a time when the worker and/or the item get to or arrive at the second intermediate production stage. A sum of the intermediate production times associated with a particular item may be equal to the item production time for the particular item.

In another example, the performance data may include an item performance. The item performance may be calculated using Equation 2 below:

$$\text{Item Performance} = \left(\frac{\text{Ideal Production Time}}{\text{Item Production Time}} \right) \quad \text{Equation 2}$$

The item performance may be a quotient of the item production time (Item Production Time) compared to an ideal production time (Ideal Production Time). The ideal production time may be a standardized item production time. For example, the ideal production time may be based on input obtained from a modelling system. The modelling system may model one or more physical environments and production of the item in the one or more modelled physical environments based on modelling parameters (e.g., physical environment layout, workers, etc.) to generate production times. In some embodiments, the ideal production time may be an average production time for production of the item in the one or more modelled physical environments from the production times. In other embodiments, the ideal production time may be a particular production time (e.g., a fastest production time as compared to other production times) from the production times or a ratio of a particular production time (e.g., 90% of a fastest production time). In other embodiments, the ideal production time may be a mean or average production time of one or more physical environments with a similar physical environment layout, physical environment location, a time of day and/or any other physical environment attributes or information. In other embodiments, the ideal production time may be based on production time standards. The production time standard may be statically significant. In certain embodiments, the ideal production time and/or the production time standard may be updated periodically. The ideal production time and/or the production time standard may be updated based on product offerings. The ideal production time may be a time to produce an item if the work center **202** and the distribution point **204** were at a same location (i.e., no distance between the work center and the distribution point **204**).

In certain embodiments, Equation 2 may be used to determine intermediate item performance. The intermediate item performance may be a quotient of the intermediate item production time (Item Production Time) compared to an ideal intermediate production time (Ideal Production Time) for each intermediate production stage.

In another example, the performance data may include a work center performance and/or a distribution point performance. The work center performance may be calculated or measured by the production controller **104**, the data proces-

15

or **114**, and/or the data analysis platform **116**. The work center performance may be calculated using Equation 3 below:

Equation 3

$$\text{Work Center Performance} = \frac{(\text{Ideal Production Time}_{Item\ 1} \times \text{Count}_{Item\ 1}) + (\text{Ideal Production Time}_{Item\ n} \times \text{Count}_{Item\ n}) \dots}{\sum_{Item\ 1 \rightarrow n} \text{Production Time(s)}}$$

The work center performance may be a quotient of a sum of all item production times for each item produced at a work center **202** over a period of time ($\sum_{Item\ 1 \rightarrow n}$ Production Time(s)) compared to a sum of ideal production times for each item produced at a work center **202** over a period of time ((Ideal Production Time_{Item 1} × Count_{Item 1}) + (Ideal Production Time_{Item n} × Count_{Item n})) (e.g., as determined by a modelling system).

In certain embodiments, Equation 3 may be used to determine intermediate work center performance **306B**. The intermediate work center performance may be a quotient of a sum of all intermediate item production times for each portion of an item produced at a work center **202** over a period of time ($\sum_{Item\ 1 \rightarrow n}$ Production Time(s)) compared to a sum of ideal production times for each portion of an item produced at the work center **202** over a period of time ((Ideal Production Time_{Item 1} × Count_{Item 1}) + (Ideal Production Time_{Item n} × Count_{Item n})).

In certain embodiments, Equation 3 may be used to determine a distribution point performance. The distribution point performance may be a sum of all item production times for each item scanned by a scanner **110** at a distribution point **204** over a period of time ($\sum_{Item\ 1 \rightarrow n}$ Production Time(s)) compared to a sum of ideal production times for each item scanned by a scanner **110** at the distribution point **204** over a period of time ((Ideal Production Time_{Item 1} × Count_{Item 1}) + (Ideal Production Time_{Item n} × Count_{Item n})).

In another example, the performance data may include a physical environment performance. The physical environment performance may be calculated or measured by the production controller **104**, the data processor **114**, and/or the data analysis platform **116**. The physical environment performance may be calculated using Equation 4 below:

$$\text{Store Perf} = \frac{\sum (\text{Ideal Production Time}_{N\ Items})}{\sum (\text{Production Time}_{N\ Items})}$$

Equation 4

The physical environment performance may be a quotient of a sum of all item production times for each item produced at a physical environment over **200** over a period of time ($\sum (\text{Production Time}_{N\ Items})$) compared to a sum of ideal production times for each item produced at a physical environment **200** over a period of time ($\sum (\text{Ideal Production Time}_{N\ Items})$) (e.g., as determined by a modelling system).

The item performance, the intermediate item performance, the work center performance, the intermediate work center performance, the distribution point performance and/or the physical environment performance may be a quotient or a percentage value representative of the quotient. The item performance, the intermediate item performance, the work center performance, the intermediate work center performance, the distribution point performance and/or the

16

physical environment performance may represent an efficiency of production of a specific item, a specific work center **202**, a specific distribution point **204**, and/or a specific physical environment **200**.

5 An item performance and/or an intermediate item performance less than (i.e., ≤1) may indicate how much slower an item or a portion of the item is produced when compared to the ideal production time or the ideal intermediate production time. An item performance and/or an intermediate item performance greater than (i.e., ≥1) may indicate how much faster an item or a portion of the item is produced when compared to the ideal production time or the ideal intermediate production time.

10 A work center performance and/or an intermediate work center performance less than (i.e., ≤1) may indicate how much slower items or a portion of the items are produced at a specific work center **202** when compared to the ideal production time or the ideal intermediate production time. A work center performance and/or an intermediate work center performance greater than (i.e., ≥1) may indicate how much faster an item or a portion of the item is produced at a specific work center **202** when compared to the ideal production time **304A** or the ideal intermediate production time.

15 A distribution point performance less than (i.e., ≤1) may indicate how much slower items are produced when distributed at a specific distribution point **204** when compared to the ideal production time. A distribution point performance greater than (i.e., ≥1) may indicate how much faster an item or a portion of the item is produced when distributed at a specific distribution point **204** when compared to the ideal production time.

20 A physical environment performance less than (i.e., ≤1) may indicate how much slower items are produced at a specific physical environment **200** compared to the ideal production time. A distribution point performance greater than (i.e., ≥1) may indicate how much faster an item or a portion of the item is produced a specific physical environment **200** when compared to the ideal production time.

25 In another example, the performance data may include a speed of service. The speed of service may be calculated using Equation 5 below:

$$\text{Order Speed of Service} = \frac{\text{All Items Delivered to HOP}_{Time}}{\text{Order Created}_{Time}}$$

Equation 5

30 The speed of service (Order Speed of Service) may be a time from when an order is placed by a user (Order Created_{Time}), to a time when all items in an order have been placed at a distribution point **204** and/or scanned by a scanner **110** at a distribution point **204** (All Items Delivered to HOP_{Time}).

35 In another example, the performance data may include an order production time. The order production time may be calculated using Equation 6 below:

$$\text{Order Production Time} = \frac{\text{All Items Delivered to HOP}_{Time}}{\text{First Item Label Pulled}_{Time}}$$

Equation 6

40 The order production time (Order Production Time) may be a time from when a first label **108** associated with an item in the order is taken by a worker (First Item Label Pulled_{Time}), to a time when all items in an order have been placed at a distribution point **204** and/or scanned by a scanner **110** at a distribution point **204** (All Items Delivered to HOP_{Time}).

45 Categorized calculations of the item performance, the intermediate item performance, the work center performance, the intermediate work center performance, the distribution point performance, the physical environment performance, the speed of service, and/or the order production

17

time may be calculated for one or more of the following categories: specific items, specific variations of an item (i.e., a modified item with altered ingredients), specific workers, specific work centers **202**, specific distribution points **204**, specific categories of distribution points **204** (i.e., a drive thru counter, an pick up counter, an online order pick-up counter, a delivery order pick-up counter, etc.), specific physical environments **200**, specific times of day, specific days of the week, specific times of year, specific order origins, and/or any combination thereof.

In certain embodiments, the production controller **104**, the data processor **114** and/or the data analysis platform **116** may use the item performance, the intermediate item performance, the work center performance, the intermediate work center performance, the distribution point performance, the physical environment performance, the speed of service, the order production time, and/or categorized calculations thereof as input data for any of the calculations or optimizations described herein.

In certain embodiments, the production controller **104**, the data processor **114** and/or the data analysis platform **116** may use locations of scanners **110**/distribution points **204** in a physical environment **200**, and/or distances between the scanners **110**/distribution points **204** and work centers **202** in the physical environment **200** as input data for various calculation or optimizations.

In certain embodiments, the production controller **104**, the data processor **114** and/or the data analysis platform **116** may compare the item performance, the intermediate item performance, the work center performance, the intermediate work center performance, the distribution point performance, the physical environment performance, the speed of service, the order production time, and/or categorized calculations thereof across various categories to determine optimized physical environments **200**, physical environment layouts, worker schedules, order schedules, etc. For example, a specific worker may more efficient when producing items at a specific work center **202**, or the specific worker may more efficient when working with certain other workers.

The production controller **104**, the data processor **114** and/or the data analysis platform **116** may use the input data to generate virtual replications of physical environments **200**. The production controller **104**, the data processor **114** and/or the data analysis platform **116** may use the virtual replications of physical environments to determine optimized layouts for specific physical environments **200**.

In certain embodiments, based on the input data, the production controller **104**, the data processor **114** and/or the data analysis platform **116** may determine optimized layouts for the physical environment **200**, wherein optimized layouts for the physical environment **200** are based on layouts with a calculated highest efficiency or calculated highest item performance, intermediate item performance, work center performance, intermediate work center performance, distribution point performance, physical environment performance, and/or the calculated smallest speed of service, and/or order production time. In some embodiments, a modelling system may calculate the item performance, the intermediate item performance, the work center performance, the intermediate work center performance, the distribution point performance, the physical environment performance, the speed of service, and/or the order production time for one or more modelled physical environments with various modelling parameters. Further, the modelling system may compare one or more of the item performance, the intermediate item performance, the work center perfor-

18

mance, the intermediate work center performance, the distribution point performance, the physical environment performance, the speed of service, and/or the order production time for the one or more modelled physical environments with the various modelling parameters to determine recommended physical environment parameters.

In certain embodiments, the production controller **104**, the data processor **114** and/or the data analysis platform **116** may determine worker work schedules based on input data. The production controller **104**, the data processor **114** and/or the data analysis platform **116** may determine worker work schedules to optimize production for a physical environment **200**, wherein optimized production is based on worker schedules with a calculated highest efficiency or calculated highest item performance, intermediate item performance, work center performance, intermediate work center performance, distribution point performance, physical environment performance, and/or the calculated smallest speed of service, and/or order production time.

In certain embodiments, the production controller **104**, the data processor **114** and/or the data analysis platform **116** may use input data to determine items with the lowest production efficiency. The production controller **104**, the data processor **114** and/or the data analysis platform **116** may optimize production for each item, wherein optimized production is based on physical environment layouts for each item with a calculated highest production efficiency.

In certain embodiments, the production controller **104**, the data processor **114** and/or the data analysis platform **116** may determine a last item produced in an order. The last item produced in an order may be the last item in the order to be placed at a distribution point **204** and/or scanned by a scanner **110** at a distribution point **204**. In certain embodiments, the production controller **104**, the data processor **114** and/or the data analysis platform **116** may determine and keep track of which work center **202** and/or worker produced the last item produced. In certain embodiments, the production controller **104**, the data processor **114** and/or the data analysis platform **116** may determine and keep track of which work centers **202** produced the last item produced. In certain embodiments, the production controller **104**, the data processor **114** and/or the data analysis platform **116** may determine or keep track of a production channel **206** of the last item produced.

In certain embodiments, the production controller **104**, the data processor **114** and/or the data analysis platform **116** may use the last item produced, the work center **202** and/or the worker that produced the last item, and/or the production channel **206** as input data for any of the calculations or optimizations described herein.

In certain embodiments, the production controller **104**, the data processor **114** and/or the data analysis platform **116** may use the input data to calculate an optimized order schedule. The optimized order schedule may be based on an order schedule with a highest efficiency, wherein an order schedule with the highest efficiency is an order schedule with a calculated highest item performance, intermediate item performance **302B**, work center performance, intermediate work center performance, distribution point performance, physical environment performance, and/or the calculated smallest speed of service, and/or order production time as compared to other order schedules. In certain embodiments, the optimized schedule may be calculated for each physical environment.

In certain embodiments, the production controller **104**, the data processor **114** and/or the data analysis platform **116** may use the input data to calculate optimized item pricing.

The optimized item pricing may be based at least in part on an item production time. For example, the production controller **104**, the data processor **114** and/or the data analysis platform **116** may determine a higher price, as compared to the price of another item, for an item that has a higher production time as compared to the production time of the another item.

In some embodiments, the production controller **104**, the data processor **114** and/or the data analysis platform **116** may execute a machine learning model based at least in part on the input data. For example, the production controller **104**, the data processor **114** and/or the data analysis platform **116** may provide the input data to the machine learning model as an input. The machine learning model may output performance data based on the input data. For example, the machine learning model may predict performance data associated with the one or more first machines based at least in part on the input data. For example, the machine learning model may predict performance data associated with an espresso machine, a milk frother, a coffee maker, an oven, an object component indication system, a distribution device, or a production system, etc. The production controller **104**, the data processor **114** and/or the data analysis platform **116** may instruct execution of a machine according to the performance data.

In some embodiments, to instruct execution of the machine, the production controller **104**, the data processor **114** and/or the data analysis platform **116** may generate at least one of a layout or a schedule based at least in part on the performance data. For example, the production controller **104**, the data processor **114** and/or the data analysis platform **116** may generate a layout of one or more machines based on the performance data, a worker schedule, a machine schedule, etc. In some embodiments, the performance data may include at least one of a layout or a schedule. The production controller **104**, the data processor **114** and/or the data analysis platform **116** may instruct the machine to output the at least one of the layout or the schedule. For example, the production controller **104**, the data processor **114** and/or the data analysis platform **116** may instruct the machine to display (e.g., via a user interface), print, etc. the layout and/or the schedule.

In some embodiments, the production controller **104**, the data processor **114** and/or the data analysis platform **116** may instruct the one or more first machines to automatically perform one or more operations in a particular order. For example, the production controller **104**, the data processor **114** and/or the data analysis platform **116** may instruct a first machine to perform a first operation at a first time, a second machine to perform a second operation at a second time subsequent to the second time, etc.

In some embodiments, the production controller **104**, the data processor **114** and/or the data analysis platform **116** may instruct execution of one or more second machines according to the performance data. For example, the input data and/or the performance data may correspond to one or more first machines and the production controller **104**, the data processor **114** and/or the data analysis platform **116** may utilize input data and/or performance data corresponding to one or more first machines to instruct execution of one or more second machines.

In some embodiments, the production controller **104**, the data processor **114** and/or the data analysis platform **116** may train the machine learning model using training data to obtain a trained machine learning model. The production

controller **104**, the data processor **114** and/or the data analysis platform **116** may execute the trained machine learning model.

Simulated Virtual Environments

Systems, methods, and devices for simulating virtual environments are described in U.S. application Ser. No. 18/053,726, filed on Nov. 8, 2022, which is hereby incorporated by reference in its entirety for all purposes.

The production controller **104**, the data processor **114**, and/or the data analysis platform **116** as describe above with reference to FIGS. 1A-2C may be any of the physical environment management system **302**, the production computing system **304**, the inventory management computing system **306** (e.g., an object management computing system), the simulation computing system **308**, and/or the management system **312** described below with reference to FIGS. 3-5.

The production data **111**, all or a portion of the performance data calculated and/or determined (e.g., by the production controller **104**, the data processor **114**, and/or the data analysis platform **116**), and/or any of the other data or information described above with reference to FIGS. 1A-2C may be the performance data, the production data, and/or any of the data described below with reference to FIGS. 3-5.

FIG. 3 is a block diagram of an illustrative operating environment **300** in which a physical environment management system **302** (e.g., a computing system associated with a physical environment) and a simulation computing system **308** (e.g., a computing system for implementing a simulation platform for generation of virtualizations associated with the physical environment) may interact with management system **312** via a network **310**. For example, the virtualizations may include virtual replications, virtual environments, virtual physical environments, virtual models, simulations, etc.

While the below disclosure discusses a particular physical environment (e.g., a store), it will be understood that the below disclosure can be implemented with respect to any physical environment (e.g., a store, a building, an office, a factory, a business, etc.).

The physical environment management system **302**, the simulation computing system **308**, and the management system **312** may be a closed loop system. By way of illustration, the physical environment management system **302** may include various types of computing devices and/or computing systems that may be in communication with the management system **312**, including a desktop computer, laptop, and a mobile phone. In general, the management system **312** can be any computing device such as a desktop, laptop or tablet computer, personal computer, wearable computer, server, personal digital assistant (PDA), hybrid PDA/mobile phone, mobile phone, electronic book reader, set-top box, voice command device, camera, digital media player, and the like.

By way of further illustration, the simulation computing system **308** can include various types of computing devices and/or computing systems for implementing the simulation platform, including a server, a desktop computer, a laptop computer, a mobile phone, etc. In general, the simulation computing system **308** may be any computing device for implementing the simulation platform and may be in communication with the management system **312** in order to receive physical environment data and generate a virtual replication of the physical environment based on the physical environment data. In some embodiments, the simulation computing system **308** may include a general computing device hosting particular software for implementing the

simulation platform. Therefore, the simulation computing system **308** may be any computing device for implementing a simulation platform for building virtual replications of a physical environment.

The management system **312** may route the physical environment data to the simulation computing system **308** and may receive and compare production data associated with the virtual replications of the physical environments. The management system **312** may provide the output to the physical environment management system **302** or any other computing devices based on the comparison. The management system **312** can provide the physical environment management system **302** (or any other computing devices) with one or more user interfaces, command-line interfaces (CLI), application programming interfaces (API), and/or other interfaces for displaying one or more outputs based on the comparison (e.g., as part of a computer display). Although one or more embodiments may be described herein as using a user interface, it should be appreciated that such embodiments may, additionally or alternatively, use any CLIs, APIs, or other interfaces.

Network

The physical environment management system **302**, the simulation computing system **308**, and the management system **312** may communicate via a network **310**, which may include any wired network, wireless network, or combination thereof. For example, the network **310** may be a personal area network, local area network, wide area network, over-the-air broadcast network (e.g., for radio or television), cable network, satellite network, cellular telephone network, or combination thereof. As a further example, the network **310** may be a publicly accessible network of linked networks, possibly operated by various distinct parties, such as the Internet. In some embodiments, the network **310** may be a private or semi-private network, such as a corporate or university intranet. The network **310** may include one or more wireless networks, such as a Global System for Mobile Communications (GSM) network, a Code Division Multiple Access (CDMA) network, a Long Term Evolution (LTE) network, or any other type of wireless network. The network **310** can use protocols and components for communicating via the Internet or any of the other aforementioned types of networks. For example, the protocols used by the network **310** may include Hypertext Transfer Protocol (HTTP), HTTP Secure (HTTPS), Message Queue Telemetry Transport (MQTT), Constrained Application Protocol (CoAP), and the like. Protocols and components for communicating via the Internet or any of the other aforementioned types of communication networks are well known to those skilled in the art and, thus, are not described in more detail herein. In some embodiments, one or more of the physical environment management system **302**, the simulation computing system **308**, the management system **312** may communicate with the inventory management computing system **306** and/or the production computing system **304** via the network **310**.

Inventory Management System

The inventory management computing system **306** may be implemented directly in hardware or software executed by hardware devices and may, for instance, include one or more physical or virtual servers implemented on physical computer hardware configured to execute computer executable instructions for performing various features that will be described herein.

The inventory management computing system **306** may receive inventory data from one or more sensors and/or one or more data stores. For example, the inventory management

computing system **306** may identify inventory (e.g., products, equipment, items, etc.) allocated to or associated with a particular physical environment. For example, the inventory may include food products (e.g., sandwiches, eggs, sugar, artificial sweetener, etc.), drink products (e.g., coffee, tea bags, milk, cream, etc.), non-food or drink products (e.g., nitrogen, cutlery, napkins, straws, etc.), or any other products associated with the physical environment. Further, the inventory management computing system **306** may identify inventory data associated with (e.g., delivered to) a particular physical environment. For example, the inventory management computing system **306** may be in communication with and/or may include one or more sensors (e.g., cameras) for monitoring the delivery of inventory. Further, the inventory management computing system **306** may manage the provision of the inventory. The inventory management computing system **306** may be in communication with and/or may include one or more sensors for managing previously delivered inventory. For example, the inventory management computing system **306** may include one or more sensors for managing inventory stored in a storeroom. In some embodiments, the inventory management computing system **306** may identify the inventory data based on worker feedback (e.g., robot worker feedback or human worker feedback). The worker feedback may include an indication of inventory dispense (e.g., dispensed to users). Further, based on receiving the worker feedback, the inventory management computing system **306** may validate the accuracy of the worker feedback. For example, the inventory management computing system **306** may calculate an amount of inventory based on the worker feedback and may validate the amount of inventory (e.g., by confirming the amount of inventory was provided to users or the amount of inventory remains in the physical environment). In some embodiments, the inventory management computing system **306** may identify the inventory data based on tracked purchases. For example, the inventory management computing system **306** may identify a base amount of inventory and may modify the based amount of inventory based on the tracked purchases.

The inventory management computing system **306** may periodically or aperiodically provide the inventory data to the physical environment management system **302**. For example, the inventory management computing system **306** may provide the inventory data to the physical environment management system **302** every hour, every day, etc. In some embodiments, the inventory management computing system **306** may provide the inventory data to the physical environment management system **302** based on a request from the physical environment management system **302**.

Production Computing System

The production computing system **304** may be implemented directly in hardware or software executed by hardware devices and may, for instance, include one or more physical or virtual servers implemented on physical computer hardware configured to execute computer executable instructions for performing various features that will be described herein.

As will be discussed below, the production computing system **304** may receive performance data from one or more sensors, computing systems, and/or one or more data stores. The performance data may identify how one or more components (e.g., workers, equipment, etc.) are performing. The production computing system **304** may include one or more computing systems for identifying performance data associated with the physical environment. In some embodiments, the production computing system **304** may include a com-

puting system (e.g., a vision system) for monitoring worker movement and worker utilization. For example, the production computing system 304 may be in communication with and/or may include a plurality of sensors stationed at various locations throughout the physical environment. The production computing system 304 may utilize the sensors to identify workers and assign tasks to workers. Based on the assigned tasks to workers, the production computing system 304 can determine efficiency associated with particular tasks or particular workers, timing associated with particular tasks or particular workers, etc. In some embodiments, the production computing system 304 may include a computing system for monitoring machine utilization and/or performance. For example, the production computing system 304 may be in communication with and/or may include a plurality of machines (e.g., the machines or sensors associated with the machines) to identify machine timing and/or machine efficiency. The plurality of machines may include a refrigerator, a freezer, a water filtration system, a heating, ventilation, and air conditioning system, an oven, a coffee machine, an espresso machine, a food display case, a chilled food display case, a blender, a specialty coffee machine, etc. Further, the plurality of machines may include multiple of the same type of machine (e.g., the plurality of machines may include multiple blenders). Each of the plurality of machines may communicate with the production computing system via a network (e.g., network 310). In some embodiments, the production computing system 304 may include a computing system for monitoring overall performance (e.g., order timing, order history, order efficiency, physical environment capacity, drive thru capacity, etc.). For example, the production computing system 304 may monitor the number of orders placed in or at a physical environment, the number of orders placed via the drive-thru, the wait time associated with particular orders (e.g., in-building orders and/or drive-thru orders), etc.

The production computing system 304 may periodically or aperiodically provide the performance data to the physical environment management system 302. For example, the production computing system 304 may provide the performance data to the physical environment management system 302 every hour, every day, etc. In some embodiments, the production computing system 304 may provide the performance data to the physical environment management system 302 based on a request from the physical environment management system 302.

Physical Environment Management System

To manage the data associated with a particular physical environment, the physical environment management system 302 can receive a plurality of data from the production computing system 304, the inventory management computing system 306, and/or any other computing systems. The physical environment management system 302 can parse the plurality of data in order to generate the production data. For example, the physical environment management system 302 can parse (e.g., filter, modify, etc.) The plurality of data to identify production data associated with the particular physical environment. For example, the physical environment management system 302 can filter the plurality of data associated with a particular time period (e.g., a particular day), a particular physical environment, a particular location within the physical environment (e.g., particular machines), a particular worker associated with the physical environment, etc. Therefore, the physical environment management system 302 can filter the plurality of data to identify particular production data. In an illustrative embodiment, the physical environment management system 302 is a user

computing device and a user may identify or select particular data. For example, the user may designate particular data (e.g., data associated with particular machines, particular inventory, particular workers, etc.) as production data. The physical environment management system 302 may include a variety of components to enable interaction between the physical environment management system 302 and a user. For example, the physical environment management system 302 may include a display system (e.g., a user interface) that causes display of information via the physical environment management system 302. In one embodiment, the display may be displayed by an additional computing system.

The physical environment management system 302 may further identify physical environment data associated with the physical environment. The physical environment data may identify a configuration of the physical environment. For example, the configuration of the physical environment may include a physical environment layout, a physical environment design, a worker allocation, a machine allocation, a machine layout, physical environment operation parameters, ordering parameters, or any other data associated with the configuration of the physical environment. The physical environment data may identify a physical layout of the physical environment. For example, the physical environment data may identify the placement, type, and quantity of tables, chairs, registers, machines, products, etc. Further, the physical environment data may identify whether the physical environment includes a drive-thru component and/or a walk-in component. The physical environment data may also identify the workers allocated to the physical environment. For example, the physical environment data may identify the number, role, and/or type (e.g., management, years, or levels of experience, etc.) of workers that are allocated to the physical environment. Further, the physical environment data may identify how orders are processed and handled by the workers with the physical environment. For example, whether orders are linked to the first available workers, whether certain orders are linked together, etc. The physical environment data may further identify menu options. For example, the physical environment data may identify food and/or drink options that are available for purchase at a particular physical environment (e.g., some physical environments may not offer particular products such as cold brew coffee). The physical environment management system 302 may identify the physical environment data based on user input (e.g., via a user computing device) and/or via one or more sensors (e.g., one or more cameras to capture the configuration of the physical environment). Therefore, the physical environment management system 302 can identify production data identifying production of the physical environment and physical environment data identifying a configuration of the physical environment.

Simulation Computing System

The physical environment management system 302 may route the physical environment data to the management system 312, and the management system 312 may route the physical environment data to the simulation computing system 308. In some embodiments, the simulation computing system 308 may receive the physical environment data directly from the physical environment management system 302. The simulation computing system 308 may receive the physical environment data and implement a simulation platform for generating a virtual replication of the physical environment based on the physical environment data. The simulation platform can perform modeling (e.g., physical environment modeling) in order to build a virtual replication of the physical environment that is based on the configura-

tion of the physical environment. Further, the virtual replication of the physical environment built by the simulation platform may produce virtual production data that is the same as or similar to the production data produced by the physical environment. For example, the simulation platform may be trained based on known mappings of physical environment data to production data such that the simulation platform can generate a virtual replication of the physical environment that produces virtual production data that tracks the production data produced by the physical environment.

The simulation computing system 308 may further generate a plurality of virtual modified replications of the physical environment by modifying all or a portion of the physical environment data associated with the physical environment. For example, the simulation computing system 308 may generate a first virtual modified replication of the physical environment by adding or removing particular machines, a second virtual modified replication of the physical environment by adding or removing an ordering option, a third virtual modified replication of the physical environment by adding or removing particular options from the menu, etc.

In order to determine the production data associated with each virtual replication of the physical environment, the simulation computing system 308 may simulate the virtual replication of the physical environment and determine production data for each virtual replication of the physical environment. In simulating the virtual replication of the physical environment, the simulation computing system 308 can provide various production and/or labor scenarios to the virtual replication of the physical environment and simulate how the virtual replication of the physical environment responds to each scenario based on the physical environment data. Further, the simulation computing system 308 can obtain various timing data associated with particular orders (e.g., particular products) and/or particular tasks (e.g., cleaning machines, making a particular drink, etc.). Therefore, the simulation computing system 308 can identify virtual production data associated with each virtual replication of the physical environment.

Management System

In order to generate an output associated with the physical environment, the management system 312 may receive the production data associated with the physical environment from the physical environment management system 302 and the virtual production data associated with each of the virtual replications of the physical environment from the simulation computing system 308. The management system 312 may include one or more components to compare the production data and the virtual production data. In some embodiments, the management system 312 may include a machine learning model (e.g., a neural network) trained to identify a particular optimized set of physical environment data (e.g., a configuration of the physical environment) based on the production data and the virtual production data. Further, the management system 312 may compare the production data and the virtual production data to determine if differences (e.g., statistically significant differences) exist between the production data and the virtual production data. The management system 312 may then determine if the difference between the production data and the virtual production data exceeds a particular threshold (e.g., a threshold set by a user via a user computing device).

The management system 312, based on identifying a difference between a particular set of virtual production data and the production data, can generate an output associated

with the physical environment. The management system 312 can cause the output to be displayed via a user computing device (e.g., the physical environment management system 302). In some embodiments, the management system 312 can cause the automatic implementation of particular physical environment data. For example, the management system 312 may automatically adjust how orders are processed and assigned to the workers based on identifying that the adjustment is associated with increases in speed of service, worker efficiency, machine efficiency, etc.

Layout Data Store

The management system 312 may include a layout data store 318. The layout data store 318 may identify one or more layouts that are available for a particular physical environment. For example, the layout data store 318 may identify layouts previously associated with the physical environment, layouts associated with similar physical environments, layouts derived from the current layout of the physical environment (e.g., by modifying particular physical environment data associated with the current physical environment data). The layouts identified by the layout data store 318 may indicate physical layouts of the physical environment. For example, the layouts may indicate a physical layout of the machines, the tables and/or chairs, the merchandise and/or the merchandise stands, the restroom(s), and/or any other physical components within the physical environment. The layouts may further identify a size and/or shape of the physical environment (e.g., via a floorplan associated with the physical environment). By identifying the layouts, the management system 312 may dynamically monitor and identify potential layouts for the physical environment. Further, the management system 312 can provide the potential layouts to the simulation computing system 308 for generation of the virtual replications of the physical environment. In some embodiments, the management system 312 may also store the current layout of the physical environment in the layout data store 318.

Worker and Inventory Data Store

Further, the management system 312 may include a worker and inventory data store 320. The worker and inventory data store 320 may identify worker and/or inventory data (e.g., potential worker allocations and/or potential inventory allocations) for a particular physical environment. For example, the worker and inventory data store 320 may identify a number of workers (e.g., five workers), a type of workers (e.g., management, non-management, etc.), a number of workers for a particular station (e.g., two workers are assigned to an espresso machine), an experience level of workers (e.g., five years of experience, no experience, training, etc.), a schedule for the workers, or any other worker data for allocation of workers to the physical environment. Further, the worker and inventory data store 320 may identify a quantity of inventory, a type of inventory, a location of inventory, an inventory delivery schedule, an amount of inventory to order, a product mix, or any other inventory data for allocation of inventory to the physical environment. The worker and/or inventory data allocations of workers and/or inventory previously associated with the physical environment, allocations of workers and/or inventory associated with similar physical environments, allocations of workers and/or inventory derived from the current allocation of workers and/or inventory of the physical environment (e.g., by modifying particular physical environment data associated with the current physical environment data). By identifying the worker and/or inventory data, the management system 312 may dynamically monitor and identify potential allocations of workers and/or inventory for the

physical environment. Further, the management system **312** can provide the potential allocations of workers and/or inventory to the simulation computing system **308** for generation of the virtual replications of the physical environment. In some embodiments, the management system **312** may also store the current allocation of workers and/or inventory of the physical environment in the worker and inventory data store **320**.

Channel Data Store

The management system **312** may include a channel data store **322**. The channel data store **322** may identify one or more potential mixtures of channels (e.g., channels of traffic) for a particular physical environment. Further, the mixtures of channels identified by the channel data store **322** may indicate physical channels of traffic of the physical environment. For example, the channel data store **322** may identify potential mixture of traffic (e.g., in-environment traffic, drive-thru traffic, curbside traffic, mobile order (e.g., orders placed via a user computing device) traffic, or any potential channel of traffic to the physical environment). Further, the channel data store **322** may identify different potential mixtures of the different channels of traffic. For example, a first mixture may include 90% of traffic is in-environment traffic and 30% of traffic is drive-thru traffic, a second mixture may include 59% of traffic is mobile ordering traffic, 21% of traffic is curbside traffic, and 20% of traffic is in-environment traffic, etc. It will be understood that the mixtures of channels may include any combination of different channels of traffic. By identifying the mixtures of channels, the management system **312** may dynamically monitor and identify potential mixtures of channels for the physical environment. Further, the management system **312** can provide the potential mixtures of channels to the simulation computing system **308** for generation of the virtual replications of the physical environment. In some embodiments, the management system **312** may also store the current mixture of channels of the physical environment in the channel data store **322**.

It will be understood that many of the components described in FIG. 3 are optional, and that embodiments of the present disclosure may combine or reorganize the components. Further, embodiments of the present disclosure may include less, different, or more components. Furthermore, the components need not be distinct or discrete. For example, the management system **312** may be represented in a single physical device, or, alternately, may be split into multiple physical devices.

Process for Generating Virtual Replications of a Physical Environment

To further illustrate how the simulation computing system **308** may generate virtual replications of a physical environment and provide associated, virtual replication data to a management system, FIG. 4A depicts illustrative interactions **400A** for identifying physical environment data, generating virtual replications of a physical environment based on the physical environment data, and providing virtual production data based on the virtual replications of the physical environment. The interactions **400A** of FIG. 4A may occur, for example, during operation of a physical environment and/or in response to a prompt from a user. Further, the interactions **400A** may occur or after an initial configuration of a physical environment.

The interactions of FIG. 4A begin at (1), where a physical environment management system **302** identifies physical environment data of a physical environment. The physical environment management system **302** may identify the physical environment data based on a physical environment

identifier associated with a particular physical environment (e.g., a physical environment identifier assigned and/or provided to the physical environment management system). The physical environment management system **302** may receive the physical environment data via a registration process of the physical environment with the physical environment management system **302**. Further, the physical environment management system **302** may receive the physical environment data as batch physical environment data or as streaming physical environment data (e.g., physical environment data received in real time). In some embodiments, the physical environment management system **302** may receive the physical environment data from a user computing device, one or more sensors, and/or any other devices. Further, the physical environment management system **302** may identify the physical environment data by analyzing the operation of the physical environment (e.g., to determine the physical environment configuration). The physical environment management system **302** may store the identified physical environment data and may update the stored physical environment data based on subsequently identified physical environment data.

The physical environment data may include data identifying the configuration of the physical environment. For example, the physical environment data may include data identifying a time period for production of particular products and/or particular orders (e.g., a time period for completion of particular orders by hand, by machine, etc.). Further, the physical environment data may include data identifying a time period for particular tasks (e.g., a time required for completion of a particular task). The physical environment data may also include physical environment layout data, worker allocation data, product mixture data, channel mixture data, order data, etc. For example, the physical environment data may identify a physical environment schematic and/or floorplan, the production engine layout of the physical environment, the physical layout of the physical environment, the physical layout of machines within the physical environment, the physical layout of the drive-thru, the physical layout of furniture within the physical environment, a quantity, type, and/or quality of machines within the physical environment, a mixture of channels of traffic associated with the physical environment, a mixture of products associated with the physical environment, worker allocation, an order history, etc. The mixture of products associated with the physical environment may identify a mixture of product types and/or number of items for each order (e.g., 40% of orders include at least 2 items, 40% of orders include an americano, etc.). Further, the mixture of channels may identify a mixture of channels of traffic (e.g., 30% of orders are ordered via a drive-thru, 20% of orders are ordered in-environment, 10% of orders are ordered via a mobile order, etc.) The order history may identify a course of orders across a day (e.g., the order history may identify a peak order time window, a non-peak order time window, etc.). Therefore, the physical environment management system **302** can identify the physical environment data of the physical environment.

Based on identifying the physical environment data, at (2), the physical environment management system **302** provides the physical environment data to the management system **312**. The physical environment management system **302** may parse the physical environment data and provide a subset of the physical environment data to the management system **312**. In some embodiments, the physical environment management system **302** may provide the physical environment data to a physical environment data store. For

example, the physical environment management system **302** may store the physical environment data in a physical environment data store with an identifier of the physical environment associated with the physical environment data. The management system **312** may obtain the physical environment data from the data store based on the identifier of the physical environment associated with the physical environment data. Therefore, the physical environment management system **302** may provide the physical environment data to the management system **312**.

Based on receiving the physical environment data, at (3), the management system **312** provides the physical environment data to the simulation computing system **308** for generation of virtual replications of the physical environment. The management system **312** may provide the physical environment data obtained from the simulation computing system **308** or a subset of the physical environment data obtained from the simulation computing system **308** to the simulation computing system. Further, the management system **312** may provide the physical environment data with a request to generate virtual replications of the physical environment. Further, the management system **312** may indicate how the simulation computing system **308** is to generate the one or more replications of the physical environment based on the physical environment data. Therefore, the management system **312** may provide the physical environment data to the simulation computing system **308**.

To identify modified versions of the physical environment, at (4), the simulation computing system **308** generates the one or more virtual replications of the physical environment. To generate the one or more virtual replications of the physical environment, the simulation computing system may provide input data to a simulation platform. In some embodiments, the input data may be a script for the generation of the one or more virtual replications of the physical environment. The input data may include one or more base inputs associated with the physical environment (or a plurality of physical environments). For example, the base inputs may include inputs or parameters (e.g., timing data that is associated with a plurality of physical environments). The input data may also include one or more customized inputs associated with the physical environment. The customized inputs may include the physical environment data. Based on the provided input data, the simulation computing system **308** can generate a virtual replication of the physical environment. Further, the simulation computing system **308** can modify one or more inputs or parameters of the input data to generate a modified virtual replication of the physical environment. The modified virtual replication of the physical environment may identify how the physical environment would operate if one or more parameters were changed. For example, the modified virtual replication of the physical environment may identify how operation of the physical environment would change if the physical environment layout were modified (e.g., an ordering option was removed). The simulation computing system **308** may generate a plurality of modified virtual replications of the physical environment. Therefore, the simulation computing system **308** can generate one or more virtual replications of the physical environment.

Based on the one or more virtual replications of the physical environment, at (5), the simulation computing system **308** provides virtual production data to the management system **312**. The simulation computing system **308** may generate the one or more virtual replications of the physical environment and simulate the operation of the one or more virtual replications of the physical environment.

Based on the simulation of the operation of the one or more virtual replications, the simulation computing system may identify virtual production data associated with the one or more virtual replications. For example, each of the one or more virtual replications may produce virtual replication data identifying the operation of the corresponding virtual replication. In some embodiments, the simulation computing system **308** and/or the management system **312** may identify key performance indicators based on the virtual production data. For example, the key performance indicators may include a speed of service (e.g., per item, per physical environment, per queue length, etc.), a worker utilization and/or efficiency (e.g., per worker), a throughput (e.g., per machine, per station of the physical environment, etc.), etc. based on the virtual production data. Therefore, the simulation computing system **308** can provide the virtual production data to the management system **312**.

To further illustrate how the management system **312** can generate the virtual replications of the physical environment, FIG. 4B depicts illustrative interactions **400B** for generating the virtual replications of the physical environment, including comparing production data and virtual production data. The interactions **400B** of FIG. 4B may occur, for example, after a simulation computing system **308** has simulated the performance of one or more virtual replications of a physical environment to identify virtual production data. Further, the interactions **400B** may occur after an initial configuration of the physical environment. In some embodiments, the interactions **400B** may occur subsequent to the interactions **400A** of FIG. 4A.

The interactions of FIG. 4B begin at (1), where a physical environment management system **302** identifies production data of the physical environment. The physical environment management system **302** may identify the production data based on a physical environment identifier associated with a particular physical environment (e.g., a physical environment identifier assigned and/or provided to the physical environment management system). The production data may identify a performance of the physical environment that may be based at least in part on the configuration of the physical environment identified by the physical environment. Further, the production data may identify how the physical environment is operating based on the physical environment data. For example, the physical environment management system **302** may analyze the production data to identify key performance indicators (e.g., a speed of service, worker utilization data, machine utilization data, efficiency, etc.). The physical environment management system **302** may receive the production data as the physical environment is operated. For example, the physical environment management system **302** may periodically or aperiodically receive production data identifying worker data, machine data, overall performance data, inventory data, etc. Further, one or more computing devices may periodically report the production data to the physical environment management system **302**. The physical environment management system **302** may receive the production data as batch production data or as streaming production data (e.g., production data received in real time). As discussed above, the physical environment management system **302** may receive the production data from a user computing device, one or more sensors, and/or any other devices. Therefore, the physical environment management system **302** can identify the production data of the physical environment.

Based on identifying the production data, at (2), the physical environment management system **302** provides the production data to the management system **312**. The physi-

31

cal environment management system **302** may parse the production data and provide a subset of the production data to the management system **312**. The physical environment management system **302** may provide the production data to the management system **312** subsequent to, during, or after simulation of the virtual replications of the physical environment by the simulation computing system **308** to generate the virtual production data. In some embodiments, the physical environment management system **302** may provide the production data to a production data store. For example, the physical environment management system **302** may store the production data in a production data store with an identifier of the physical environment associated with the production data. The management system **312** may obtain the production data from the data store based on the identifier of the physical environment associated with the production data. Therefore, the physical environment management system **302** may provide the production data to the management system **312**.

Based on receiving the production data from the physical environment management system **302** and the virtual production data from the simulation computing system **308**, at (3), the management system **312** compares the production data and the virtual production data. The management system **312** may compare the production data and the virtual production data to identify a particular set of physical environment data (e.g., a particular physical environment configuration). For example, the management system **312** may compare the production data and the virtual production data to identify physical environment data associated with a highest speed of service, a highest worker utilization rate, a highest machine utilization rate, etc. Further, the comparison of the production data and the virtual production data may be based on one or more user goals. The one or more user goals may be associated with a user of the management system **312** and may indicate a preference or goal of the user. For example, the one or more user goals may identify a preference for increased speed of service, for increased worker utilization rate, for increased machine utilization rate, etc. Based on the one or more user goals, the management system **312** may compare specific components of the production data and the virtual production data. At a first time (e.g., during the afternoon), the user may be associated with a first user goal (e.g., increased throughput) and, at a second time (e.g., during the evening) the user may be associated with a second, different user goal (e.g., increased speed of service). In some embodiments, the management system **312** may compare the production data with a plurality of virtual production data associated with a plurality of virtual replications of the physical environment. Therefore, the management system **312** compares the production data and the virtual production data.

Based on the comparing the production data and the virtual production data, at (4), the management system **312** generates an output. The management system **312** may generate the output (or a plurality of the outputs) based at least in part on the comparison of the production data and the virtual production data and the user goals. For example, the management system **312** may generate an output based on determining whether the difference between the production data and the virtual production data exceeds a threshold (e.g., a user threshold, a system threshold, etc.) If the difference between the production data and the virtual production data exceeds the threshold, the management system **312** may generate an output that includes a modified virtual replication of the physical environment with a modified configuration of the physical environment based on

32

physical environment data associated with the virtual production data. If the difference between the production data and the virtual production data does not exceed the threshold, the management system **312** may generate an output that includes a virtual replication of the physical environment with a current configuration of the physical environment (e.g., based on a user preference to maintain the current configuration of the physical environment). For example, the output may identify a modified configuration of the physical environment with discontinued ordering, discontinued products (e.g., americanos), initiation of in-environment dining, etc. based on the virtual replication of the physical environment associated with the modification. Further, the output may include a reordering of multiple received orders and/or an order with multiple products. For example, the physical environment may receive a first order for a first product, a second order for a second product and a third product, and a third order for a fourth product. The output may include a worker schedule to assign and start production of the first product, assign and complete production of the third product, assign and start production of the second product, assign and complete production of the fourth product, and complete production of the first and second products. Therefore, the management system **312** can generate the output.

Based on the output, at (6), the management system **312** provides the output for the user to the physical environment management system **302** associated with the user. Further, the physical environment management system **302** may route the output to a user computing device associated with the user.

In response to receiving the output, the user computing device may display the output. For example, the user computing device may display the output via an interface (e.g., an API, a CLI, or any other interface). Further, the user computing device may display the output via a web page, a mobile API, a voice interface, or any other interface for the user computing device.

With reference to FIG. 5, an illustrative routine **500** will be described for generating virtual replications of the physical environment. The routine **500** may be implemented for example, by the management system **312** of FIG. 3. The routine **500** begins at block **502**, the management system **312** identifies physical environment data associated with a physical environment. For example, the physical environment data may be associated with operation of the physical environment. In some cases, the management system **312** may identify a plurality of environment data associated with a physical environment (e.g., an area, an enclosure, a store, a building, an office, a factory, a business, etc.). The physical environment data may include at least one of inventory data, physical environment configuration data, labor allocation data, physical environment layout data, and/or machine allocation data (e.g., equipment allocation data). The labor allocation may identify one or more workers associated with the physical environment (e.g., robot workers or human workers).

At block **504**, the management system **312** generates a virtual replication of the physical environment. For example, the virtual replication of the physical environment may be a virtual physical environment, a virtual model, etc. In some cases, the management system **312** may generate a virtual environment (e.g., a virtual store) modelling a physical environment (e.g., a store). The management system **312** may access a simulation platform to generate the virtual replication of the physical environment. The simulation platform may generate the virtual replication of the physical environment based on the plurality of physical environment

data. To generate the virtual replication of the physical environment, the simulation platform may run a plurality of simulations and may compare an output of each of the plurality of simulations to verify the virtual replication.

At block 506, the management system 312 production data associated with the physical environment. The management system 312 may identify the production data based on the virtual replication of the physical environment. For example, the production data may include at least one of sensor data, machine data (e.g., equipment data), ordering data, inventory data, and/or order processing data. Further, the management system 312 may receive the production data from another computing system (e.g., the physical environment management system 302). For example, the management system 312 may obtain the production data, in real time, from one or more sensors. Further, the management system 312 may obtain the production data, in real time, from a physical environment computing system associated with the physical environment. The physical environment computing system may monitor a worker associated with the physical environment and identify worker utilization data associated with the worker based on monitoring the worker. Further, the production data may include the worker utilization data. The worker utilization data may identify a status of the worker at a particular time (e.g., active, idle, walking, etc.). Further, the physical environment computing system may monitor a machine (e.g., particular equipment) associated with the physical environment and identify machine utilization data associated with the machine based on monitoring the machine. The production data may include the machine utilization data. Based on the production data, the management system 312 may determine a speed of service, a throughput, and/or labor usage associated with the physical environment.

In some cases, the management system 312 may utilize the production data to test (e.g., in real time) the virtual replication of the physical environment. For example, the management system 312 may compare the production data associated with the physical environment with production data associated with the virtual replication of the physical environment to align a data stream associated with the physical environment with a data stream associated with the virtual replication of the physical environment. The management system 312 may compare the production data associated with the physical environment with production data associated with the virtual replication of the physical environment to confirm whether the virtual replication of the physical environment is modelling the physical environment. For example, the management system 312 may confirm whether the production data associated with the physical environment matches the production data associated with the virtual replication of the physical environment within a certain degree of accuracy (e.g., 90%, 95%, 97%, etc.). In some cases, the degree of accuracy may be system-generated or user-generated. If the management system 312 determines the production data associated with the physical environment does not match the production data associated with the virtual replication of the physical environment within the certain degree of accuracy, the management system 312 may adjust (e.g., in real time) one or more values associated with the virtual replication of the physical environment and retest the physical environment. For example, the management system 312 may modify one or more values associated with a particular sensor, a particular piece of equipment, the workers, etc. The management system 312 may repeat any number of iterations of adjusting and retesting the virtual replication of the physical environment.

At block 508, the management system 312 modifies one or more values of the physical environment data to generate modified physical environment data. The management system 312 may modify one or more values of the physical environment data to generate the modified physical environment data based on identifying the production data associated with the physical environment.

In some cases, the management system 312, a separate system, and/or a user (via a user computing device) may define modifiable values of the physical environment data. The management system 312, the separate system, and/or the user may indicate that values associated with one or more of a number of partners, a type of partners, a size of the physical environment, a number of equipment, a type of equipment, an amount of waste, a drive-thru, mobile ordering, etc. are modifiable or are not modifiable. For example, the user may indicate that values associated with a number of equipment, a type of equipment, a drive-thru, and mobile ordering are modifiable, and values associated with number of partners, a type of partners, a size of the physical environment, and an amount of waste are not modifiable. Further, the management system 312, the separate system, and/or the user may provide value parameters (e.g., a range, a maximum, a minimum, an average, a mean, etc.) for one or more values. For example, a user may indicate that a value associated with a number of workers may not be modified to be over 30 workers. The management system 312 may generate the modified physical environment data based on the modifiable values and/or the parameters.

At block 510, the management system 312 generates a modified virtual replication of the physical environment. The management system 312 may access the simulation platform to generate the modified virtual replication of the physical environment. The simulation platform may generate the modified virtual replication physical environment based on the modified physical environment data. As discussed above, to generate the modified virtual replication of the physical environment, the simulation platform may run a plurality of simulations and may compare an output of each of the plurality of simulations to verify the modified virtual replication. Further, the simulation platform may map a plurality of sets of physical environment data including the physical environment data to a plurality of sets of virtual production data including the production data in order to determine how to simulate the modified virtual replication.

Based on the virtual replication and the modified virtual replication, at block 512, the management system 312 compares the modified virtual replication of the physical environment with the virtual replication of the physical environment. The comparison of the modified virtual replication of the physical environment and the virtual replication of the physical environment may be based on the production data. Further, to compare the modified virtual replication of the physical environment and the virtual replication of the physical environment, the management system 312 may compare production data associated with the modified virtual replication with the production data associated with the physical environment. In some embodiments, the management system 312 may compare a plurality of modified virtual replications of the physical environment (including the modified virtual replication of the physical environment) with the virtual replication of physical environment based on the plurality of production data. Further, the management system 312 may further determine one or more user goals and the user goals may correspond to one or more speed of service, throughput, and/or labor usage. The

comparison of the modified virtual replication and the virtual replication may be based on the one or more user goals. In some embodiments, each of the user goals may be associated with particular conditions and comparison of the modified virtual replication with the virtual replication may be based on the particular conditions.

In order to determine a physical environment configuration for the physical environment, at block 514, the management system 312 outputs the modified virtual replication of the physical environment. The output of the modified virtual replication of the physical environment may be based on comparing the modified virtual replication of the physical environment with the virtual replication of the physical environment. In some embodiments, the output of the modified virtual replication of the physical environment may be based on comparing a plurality of modified virtual replications with the virtual replication. The output may include data associated with the modified virtual replication of the physical environment. For example, the output may include a modified physical environment layout associated with the physical environment, a modified worker allocation associated with the physical environment, or a modified machine (e.g., equipment) allocation associated with the physical environment. Further, the output may include a worker schedule and a scheduling system may dynamically define the worker schedule.

In some embodiments, the management system 312 may cause display of the output. The management system 312 may cause display of the output via a display of a user computing device associated with a user.

The management system 312 may output the modified virtual replication of the physical environment as a recommendation for the user (e.g., a recommended layout of the physical environment). In some cases, to generate the recommendation, the management system 312 may compare the modified virtual replication of the physical environment and the virtual replication of the physical environment based on cost to implement the recommendation, savings based on implementing the recommendation, productivity based on implementing the recommendation, etc. For example, the management system 312 may recommend the modified virtual replication of the physical environment based on determining that the savings based on implementing the recommendation exceed the cost to implement the recommendation by a particular amount (e.g., 10%, 20%, etc.).

In some cases, the management system 312 may identify a subset of production data associated with one or more sensors of the physical environment. For example, the management system 312 may identify a first subset of the production data associated with a motion sensor associated with a drive-thru window, a second subset of the production data associated with a proximity sensor associated with a register, a third subset of the production data associated with a sensor associated with an espresso machine, etc. The management system 312 may identify the subsets of the production data based on a manner of parsing the production data. For example, a user (via a user computing device) may identify a manner of parsing the production data to identify a subset of the production data associated with a particular sensor. In some cases, a user may periodically or aperiodically update a manner of parsing the production data. For example, a user may add a sensor to the physical environment and define a manner of parsing the production data to identify a subset of the production data associated with the sensor and/or a user may update and/or add a manner of parsing the production data to identify a subset of the production data associated with a previously added sensor.

Further, the management system 312 may define a virtual sensor in the virtual replication of the physical environment corresponding to the sensor. The management system 312 may define a subset of the virtual production data associated with the virtual replication of the physical environment. Based on the subset of the virtual production data and the subset of the production data, the management system 312 may compare the physical environment and the virtual replication of the physical environment. As the management system 312 may dynamically identify and/or define a subset of data associated with a particular sensor, the management system 312 can dynamically adjust the granularity of the comparison of the physical environment and the virtual replication of the physical environment. This can enable the management system 312 to correlate the virtual replication of the physical environment to the physical environment on a dynamic granular level (e.g., based on individual sensors associated with the physical environment). In some cases, the management system 312 may tune the virtual replication of the physical environment and/or a particular virtual sensor of the virtual replication of the physical environment based on comparing the physical environment and the virtual replication of the physical environment using the subset of the virtual production data and the subset of the production data. In other cases, the management system 312 may replace the virtual replication of the physical environment based on comparing the physical environment and the virtual replication of the physical environment using the subset of the virtual production data and the subset of the production data. Further, the management system 312 can utilize the defined subset of the virtual production data to compare the modified virtual replication of the physical environment with the virtual replication of the physical environment (e.g., using the subset of the virtual production data and a subset of the modified virtual production data).

In various embodiments, the execution routine 500 may include more, fewer, different, or different combinations of blocks than those depicted in FIG. 5. For example, the routine 500 may include, in some embodiments, display of the virtual replication. As a further example, blocks 504 and 508 may be combined, and the routine 500 may access the simulation platform to generate the virtual replication and the modified virtual replications simultaneously. The routine 500 depicted in FIG. 5 is thus understood to be illustrative and not limiting.

Computer Systems

FIG. 6 is a block diagram depicting an embodiment of a computer hardware system configured to run software for implementing one or more embodiments disclosed herein.

In some embodiments, the systems, processes, and methods described herein are implemented using a computing system, such as the one illustrated in FIG. 6. The example computer system 3102 is in communication with one or more computing systems 3120 and/or one or more data sources 3122 via one or more networks 3118. While FIG. 6 illustrates an embodiment of a computer system 3102, it is recognized that the functionality provided for in the components and modules of computer system 3102 may be combined into fewer components and modules, or further separated into additional components and modules.

The computer system 3102 can comprise a module 3114 that carries out the functions, methods, acts, and/or processes described herein. The module 3114 is executed on the computer system 3102 by a central processing unit 3106 discussed further below.

In general, the word “module,” as used herein, refers to logic embodied in hardware or firmware or to a collection of

software instructions, having entry and exit points. Modules are written in a program language, such as JAVA, C or C++, Python, or the like. Software modules may be compiled or linked into an executable program, installed in a dynamic link library, or may be written in an interpreted language such as BASIC, PERL, LUA, or Python. Software modules may be called from other modules or from themselves, and/or may be invoked in response to detected events or interruptions. Modules implemented in hardware include connected logic units such as gates and flip-flops, and/or may include programmable units, such as programmable gate arrays or processors.

Generally, the modules described herein refer to logical modules that may be combined with other modules or divided into sub-modules despite their physical organization or storage. The modules are executed by one or more computing systems and may be stored on or within any suitable computer readable medium or implemented in whole or in-part within special designed hardware or firmware. Not all calculations, analysis, and/or optimization require the use of computer systems, though any of the above-described methods, calculations, processes, or analyses may be facilitated through the use of computers. Further, in some embodiments, process blocks described herein may be altered, rearranged, combined, and/or omitted.

The computer system **3102** includes one or more processing units (CPU) **3106**, which may comprise a microprocessor. The computer system **3102** further includes a physical memory **3110**, such as random-access memory (RAM) for temporary storage of information, a read only memory (ROM) for permanent storage of information, and a mass storage device **3104**, such as a backing store, hard drive, rotating magnetic disks, solid state disks (SSD), flash memory, phase-change memory (PCM), 3D XPoint memory, diskette, or optical media storage device. Alternatively, the mass storage device may be implemented in an array of servers. Typically, the components of the computer system **3102** are connected to the computer using a standards-based bus system. The bus system can be implemented using various protocols, such as Peripheral Component Interconnect (PCI), Micro Channel, SCSI, Industrial Standard Architecture (ISA) and Extended ISA (EISA) architectures.

The computer system **3102** includes one or more input/output (I/O) devices and interfaces **3112**, such as a keyboard, mouse, touch pad, and printer. The I/O devices and interfaces **3112** can include one or more display devices, such as a monitor, that allows the visual presentation of data to a user. More particularly, a display device provides for the presentation of GUIs as application software data, and multi-media presentations, for example. The I/O devices and interfaces **3112** can also provide a communications interface to various external devices. The computer system **3102** may comprise one or more multi-media devices **3108**, such as speakers, video cards, graphics accelerators, and microphones, for example.

The computer system **3102** may run on a variety of computing devices, such as a server, a Windows server, a Structure Query Language server, a Unix Server, a personal computer, a laptop computer, and so forth. In other embodiments, the computer system **3102** may run on a cluster computer system, a mainframe computer system and/or other computing system suitable for controlling and/or communicating with large databases, performing high volume transaction processing, and generating reports from large databases. The computer system **3102** is generally controlled and coordinated by an operating system software,

such as Windows XP, Windows Vista, Windows 7, Windows 8, Windows 10, Windows 11, Windows Server, Unix, Linux (and its variants such as Debian, Linux Mint, Fedora, and Red Hat), SunOS, Solaris, Blackberry OS, z/OS, iOS, macOS, or other operating systems, including proprietary operating systems. Operating systems control and schedule computer processes for execution, perform memory management, provide file system, networking, and I/O services, and provide a user interface, such as a graphical user interface (GUI), among other things.

The computer system **3102** illustrated in FIG. 6 is coupled to a network **3118**, such as a LAN, WAN, or the Internet via a communication link **3116** (wired, wireless, or a combination thereof). Network **3118** communicates with various computing devices and/or other electronic devices. Network **3118** is communicating with one or more computing systems **3120** and one or more data sources **3122**. The module **3114** may access or may be accessed by computing systems **3120** and/or data sources **3122** through a web-enabled user access point. Connections may be a direct physical connection, a virtual connection, and other connection type. The web-enabled user access point may comprise a browser module that uses text, graphics, audio, video, and other media to present data and to allow interaction with data via the network **3118**.

Access to the module **3114** of the computer system **3102** by computing systems **3120** and/or by data sources **3122** may be through a web-enabled user access point such as the computing systems' **3120** or data source's **3122** personal computer, cellular phone, smartphone, laptop, tablet computer, e-reader device, audio player, or another device capable of connecting to the network **3118**. Such a device may have a browser module that is implemented as a module that uses text, graphics, audio, video, and other media to present data and to allow interaction with data via the network **3118**.

The output module may be implemented as a combination of an all-points addressable display such as a cathode ray tube (CRT), a liquid crystal display (LCD), a plasma display, or other types and/or combinations of displays. The output module may be implemented to communicate with input devices **3112** and they also include software with the appropriate interfaces which allow a user to access data through the use of stylized screen elements, such as menus, windows, dialogue boxes, tool bars, and controls (for example, radio buttons, check boxes, sliding scales, and so forth). Furthermore, the output module may communicate with a set of input and output devices to receive signals from the user.

The input device(s) may comprise a keyboard, roller ball, pen and stylus, mouse, trackball, voice recognition system, or pre-designated switches or buttons. The output device(s) may comprise a speaker, a display screen, a printer, or a voice synthesizer. In addition, a touch screen may act as a hybrid input/output device. In another embodiment, a user may interact with the system more directly such as through a system terminal connected to the score generator without communications over the Internet, a WAN, or LAN, or similar network.

In some embodiments, the computer system **3102** may comprise a physical or logical connection established between a remote microprocessor and a mainframe host computer for the express purpose of uploading, downloading, or viewing interactive data and databases on-line in real time. The remote microprocessor may be operated by an entity operating the computer system **3102**, including the client server systems or the main server system, and/or may

be operated by one or more of the data sources **3122** and/or one or more of the computing systems **3120**. In some embodiments, terminal emulation software may be used on the microprocessor for participating in the micro-mainframe link.

In some embodiments, computing systems **3120** who are internal to an entity operating the computer system **3102** may access the module **3114** internally as an application or process run by the CPU **3106**.

In some embodiments, one or more features of the systems, methods, and devices described herein can utilize a URL and/or cookies, for example for storing and/or transmitting data or user information. A Uniform Resource Locator (URL) can include a web address and/or a reference to a web resource that is stored on a database and/or a server. The URL can specify the location of the resource on a computer and/or a computer network. The URL can include a mechanism to retrieve the network resource. The source of the network resource can receive a URL, identify the location of the web resource, and transmit the web resource back to the requestor. A URL can be converted to an IP address, and a Domain Name System (DNS) can look up the URL and its corresponding IP address. URLs can be references to web pages, file transfers, emails, database accesses, and other applications. The URLs can include a sequence of characters that identify a path, domain name, a file extension, a host name, a query, a fragment, scheme, a protocol identifier, a port number, a username, a password, a flag, an object, a resource name and/or the like. The systems disclosed herein can generate, receive, transmit, apply, parse, serialize, render, and/or perform an action on a URL.

A cookie, also referred to as an HTTP cookie, a web cookie, an internet cookie, and a browser cookie, can include data sent from a website and/or stored on a user's computer. This data can be stored by a user's web browser while the user is browsing. The cookies can include useful information for websites to remember prior browsing information, such as a shopping cart on an online store, clicking of buttons, login information, and/or records of web pages or network resources visited in the past. Cookies can also include information that the user enters, such as names, addresses, passwords, credit card information, etc. Cookies can also perform computer functions. For example, authentication cookies can be used by applications (for example, a web browser) to identify whether the user is already logged in (for example, to a web site). The cookie data can be encrypted to provide security for the consumer. Tracking cookies can be used to compile historical browsing histories of individuals. Systems disclosed herein can generate and use cookies to access data of an individual. Systems can also generate and use JSON web tokens to store authenticity information, HTTP authentication as authentication protocols, IP addresses to track session or identity information, URLs, and the like.

The computer system **3102** may include one or more internal and/or external data sources (for example, data sources **3122**). In some embodiments, one or more of the data repositories and the data sources described above may be implemented using a relational database, such as Sybase, Oracle, CodeBase, DB2, PostgreSQL, and Microsoft® SQL Server as well as other types of databases such as, for example, a NoSQL database (for example, Couchbase, Cassandra, or MongoDB), a flat file database, an entity-relationship database, an object-oriented database (for example, InterSystems Cache), a cloud-based database (for example, Amazon RDS, Azure SQL, Microsoft Cosmos DB, Azure Database for MySQL, Azure Database for MariaDB, Azure

Cache for Redis, Azure Managed Instance for Apache Cassandra, Google Bare Metal Solution for Oracle on Google Cloud, Google Cloud SQL, Google Cloud Spanner, Google Cloud Big Table, Google Firestore, Google Firebase Real-time Database, Google Memorystore, Google MongoDB Atlas, Amazon Aurora, Amazon DynamoDB, Amazon Redshift, Amazon ElastiCache, Amazon MemoryDB for Redis, Amazon DocumentDB, Amazon Keyspaces, Amazon Neptune, Amazon Timestream, or Amazon QLDB), a non-relational database, or a record-based database.

The computer system **3102** may also access one or more databases **3122**. The databases **3122** may be stored in a database or data repository. The computer system **3102** may access the one or more databases **3122** through a network **3118** or may directly access the database or data repository through I/O devices and interfaces **3112**. The data repository storing the one or more databases **3122** may reside within the computer system **3102**.

ADDITIONAL EMBODIMENTS

In the foregoing specification, the systems and processes have been described with reference to specific embodiments thereof. It will, however, be evident that various modifications and changes may be made thereto without departing from the broader spirit and scope of the embodiments disclosed herein. The specification and drawings are, accordingly, to be regarded in an illustrative rather than restrictive sense.

Indeed, although the systems and processes have been disclosed in the context of certain embodiments and examples, it will be understood by those skilled in the art that the various embodiments of the systems and processes extend beyond the specifically disclosed embodiments to other alternative embodiments and/or uses of the systems and processes and obvious modifications and equivalents thereof. In addition, while several variations of the embodiments of the systems and processes have been shown and described in detail, other modifications, which are within the scope of this disclosure, will be readily apparent to those of skill in the art based upon this disclosure. It is also contemplated that various combinations or sub-combinations of the specific features and aspects of the embodiments may be made and still fall within the scope of the disclosure. It should be understood that various features and aspects of the disclosed embodiments can be combined with, or substituted for, one another in order to form varying modes of the embodiments of the disclosed systems and processes. Any methods disclosed herein need not be performed in the order recited. Thus, it is intended that the scope of the systems and processes herein disclosed should not be limited by the particular embodiments described above.

It will be appreciated that the systems and methods of the disclosure each have several innovative aspects, no single one of which is solely responsible or required for the desirable attributes disclosed herein. The various features and processes described above may be used independently of one another or may be combined in various ways. All possible combinations and sub-combinations are intended to fall within the scope of this disclosure.

Certain features that are described in this specification in the context of separate embodiments also may be implemented in combination in a single embodiment. Conversely, various features that are described in the context of a single embodiment also may be implemented in multiple embodiments separately or in any suitable sub-combination. Moreover, although features may be described above as acting in

certain combinations and even initially claimed as such, one or more features from a claimed combination may in some cases be excised from the combination, and the claimed combination may be directed to a sub-combination or variation of a sub-combination. No single feature or group of features is necessary or indispensable to each and every embodiment.

It will also be appreciated that conditional language used herein, such as, among others, “can,” “could,” “might,” “may,” “for example,” and the like, unless specifically stated otherwise, or otherwise understood within the context as used, is generally intended to convey that certain embodiments include, while other embodiments do not include, certain features, elements and/or steps. Thus, such conditional language is not generally intended to imply that features, elements and/or steps are in any way required for one or more embodiments or that one or more embodiments necessarily include logic for deciding, with or without author input or prompting, whether these features, elements and/or steps are included or are to be performed in any particular embodiment. The terms “comprising,” “including,” “having,” and the like are synonymous and are used inclusively, in an open-ended fashion, and do not exclude additional elements, features, acts, operations, and so forth. In addition, the term “or” is used in its inclusive sense (and not in its exclusive sense) so that when used, for example, to connect a list of elements, the term “or” means one, some, or all of the elements in the list. In addition, the articles “a,” “an,” and “the” as used in this application and the appended claims are to be construed to mean “one or more” or “at least one” unless specified otherwise. Similarly, while operations may be depicted in the drawings in a particular order, it is to be recognized that such operations need not be performed in the particular order shown or in sequential order, or that all illustrated operations be performed, to achieve desirable results. Further, the drawings may schematically depict one or more example processes in the form of a flowchart. However, other operations that are not depicted may be incorporated in the example methods and processes that are schematically illustrated. For example, one or more additional operations may be performed before, after, simultaneously, or between any of the illustrated operations. Additionally, the operations may be rearranged or reordered in other embodiments. In certain circumstances, multitasking and parallel processing may be advantageous. Moreover, the separation of various system components in the embodiments described above should not be understood as requiring such separation in all embodiments, and it should be understood that the described program components and systems may generally be integrated together in a single software product or packaged into multiple software products. Additionally, other embodiments are within the scope of the following claims. In some cases, the actions recited in the claims may be performed in a different order and still achieve desirable results.

Further, while the methods and devices described herein may be susceptible to various modifications and alternative forms, specific examples thereof have been shown in the drawings and are herein described in detail. It should be understood, however, that the embodiments are not to be limited to the particular forms or methods disclosed, but, to the contrary, the embodiments are to cover all modifications, equivalents, and alternatives falling within the spirit and scope of the various implementations described and the appended claims. Further, the disclosure herein of any particular feature, aspect, method, property, characteristic, quality, attribute, element, or the like in connection with an

implementation or embodiment can be used in all other implementations or embodiments set forth herein. Any methods disclosed herein need not be performed in the order recited. The methods disclosed herein may include certain actions taken by a practitioner; however, the methods can also include any third-party instruction of those actions, either expressly or by implication. The ranges disclosed herein also encompass any and all overlap, sub-ranges, and combinations thereof. Language such as “up to,” “at least,” “greater than,” “less than,” “between,” and the like includes the number recited. Numbers preceded by a term such as “about” or “approximately” include the recited numbers and should be interpreted based on the circumstances (for example, as accurate as reasonably possible under the circumstances, for example $\pm 5\%$, $\pm 10\%$, $\pm 15\%$, etc.). For example, “about 3.5 mm” includes “3.5 mm.” Phrases preceded by a term such as “substantially” include the recited phrase and should be interpreted based on the circumstances (for example, as much as reasonably possible under the circumstances). For example, “substantially constant” includes “constant.” Unless stated otherwise, all measurements are at standard conditions including temperature and pressure.

As used herein, a phrase referring to “at least one of” a list of items refers to any combination of those items, including single members. As an example, “at least one of: A, B, or C” is intended to cover: A, B, C, A and B, A and C, B and C, and A, B, and C. Conjunctive language such as the phrase “at least one of X, Y and Z,” unless specifically stated otherwise, is otherwise understood with the context as used in general to convey that an item, term, etc. may be at least one of X, Y or Z. Thus, such conjunctive language is not generally intended to imply that certain embodiments require at least one of X, at least one of Y, and at least one of Z to each be present. The headings provided herein, if any, are for convenience only and do not necessarily affect the scope or meaning of the devices and methods disclosed herein.

Accordingly, the claims are not intended to be limited to the embodiments shown herein but are to be accorded the widest scope consistent with this disclosure, the principles and the novel features disclosed herein.

What is claimed is:

1. A system comprising:

a first hardware device located at a first physical location within a physical environment, and configured to physically output labels comprising a machine readable code, wherein the machine readable code is associated with an object, wherein the physical environment comprises:

a first physical route through the physical environment, the first physical route comprising a first route start, a first route end, and one or more first physical machines between the first route start and the first route end, and

a second physical route through the physical environment, the second physical route comprising a second route start, a second route end, and one or more second physical machines between the second route start and the second route end;

a second hardware device associated with the first physical route, the second hardware device located at a second physical location within the physical environment, and configured to optically scan the machine readable code using a first image sensor;

a third hardware device associated with the second physical route, the third hardware device located at a third physical location within the physical environment, and

43

configured to optically scan the machine readable code using a second image sensor; and
 a controller comprising:
 a memory configured to store computer-executable instructions; and
 at least one processor in communication with the memory, wherein the computer-executable instructions, when executed by the at least one processor, cause the at least one processor to:
 receive first object data associated with an object;
 instruct the first hardware device to output a label comprising the machine readable code based at least in part on the first object data;
 receive, from the first hardware device, first time data, wherein the first time data indicates an output time of the label by the first hardware device;
 receive, from the second hardware device, first production data, a second hardware device identifier, and second object data, wherein the first production data indicates 1) that the second hardware device scanned the machine readable code and 2) a scan time of the machine readable code by the second hardware device, and wherein the second hardware device identifier indicates the second physical location;
 determine, based at least in part on the first production data, the second hardware device identifier, and the second object data, input data, wherein the input data indicates that the object was produced via the first physical route, and a production time associated with the object, wherein the production time is based at least in part on the output time of the label and the scan time;
 execute a machine learning model based at least in part on the input data, wherein the machine learning model predicts performance data associated with the one or more first physical machines based at least in part on the input data; and
 instruct execution of a physical machine according to the performance data.

2. The system of claim 1, wherein to instruct execution of the physical machine, the computer-executable instructions, when executed by the at least one processor, further cause the at least one processor to:
 generate at least one of a layout or a schedule based at least in part on the performance data; and
 instruct the physical machine to output the at least one of the layout or the schedule.

3. The system of claim 1, wherein to instruct execution of the physical machine, the computer-executable instructions, when executed by the at least one processor, further cause the at least one processor to instruct the one or more first physical machines to automatically perform one or more operations in a particular order.

4. The system of claim 1, wherein the computer-executable instructions, when executed by the at least one processor, further cause the at least one processor to instruct execution of the one or more second physical machines according to the performance data.

5. The system of claim 1, wherein the one or more first physical machines comprises:
 a coffee maker;
 an oven;
 an object component indication system;
 a distribution device; or
 a production system.

44

6. The system of claim 1, wherein the computer-executable instructions, when executed by the at least one processor, further cause the at least one processor to:
 train the machine learning model using training data to obtain a trained machine learning model, wherein to execute the machine learning model, the computer-executable instructions, when executed by the at least one processor, further cause the at least one processor to execute the trained machine learning model.

7. The system of claim 1, wherein the performance data comprises a production schedule.

8. The system of claim 1, wherein the performance data comprises a layout of the one or more first physical machines.

9. The system of claim 1, wherein the second physical location is the first route end.

10. The system of claim 9, wherein the first route start is a work center, and the first route end is a distribution point.

11. The system of claim 10, wherein the distribution point is one of a pick-up counter and a drive-thru counter.

12. The system of claim 1, wherein the computer-executable instructions, when executed by the at least one processor, further cause the at least one processor to receive the first production data from the one or more first physical machines.

13. The system of claim 1, wherein the first physical route comprises one or more intermediate production stages, wherein the first route start and each of the one or more intermediate production stages comprise a work center, and at least one of the one or more intermediate production stages comprise a hardware device.

14. The system of claim 1, wherein the computer-executable instructions, when executed by the at least one processor, further cause the at least one processor to:
 receive third object data associated with a second object;
 instruct the first hardware device to output a second label comprising a second machine readable code associated with the second object based at least in part on the third object data;
 receive, from the first hardware device, second time data, wherein the second time data indicates a second output time of the second label by the first hardware device;
 receive, from the third hardware device, second production data, a third hardware device identifier, and fourth object data, wherein the second production data indicates 1) that the third hardware device scanned the second machine readable code, and 2) a second scan time of the second machine readable code by the third hardware device, and wherein the third hardware device identifier indicates the third physical location; and
 determine, based at least in part on the second production data, the third hardware device identifier, and the fourth object data, second input data, wherein the second input data indicates that the second object was produced via the second physical route, and a second production time associated with the second object, wherein the second production time is based at least in part on the second output time of the second label and the second scan time.

15. The system of claim 1, wherein the physical environment further comprises a third physical route, the third physical route comprising a third route start, a third route end, and one or more third physical machines between the third route start and the third route end wherein the third route start is the first route start, the third route end is the second route end, and the first route end is the second route

start such that the first physical route and the second physical route are intermediate production stages of the third physical route.

16. The system of claim 15, wherein the computer-executable instructions, when executed by the at least one processor, further cause the at least one processor to:

receive, from the third hardware device, second production data, a third hardware device identifier, and the second object data, wherein the second production data indicates 1) that the third hardware device scanned the machine readable code, and 2) a second scan time of the machine readable code by the third hardware device, and wherein the third hardware device identifier indicates the third physical location;

determine, based at least in part on the second production data, the third hardware device identifier, and the second object data, second input data, wherein the second input data indicates that the object was produced via the second physical route, a second production time associated with the object, wherein the second production time is based at least in part on the scan time and the second scan time; and

determine, based at least in part on the production time and the second production time, a third production time.

17. A system comprising:

a printer located at a first physical location within a physical environment, the printer configured to print labels comprising a machine readable code, wherein the machine readable code is associated with an item, wherein the physical environment comprises a route, the route comprising one or more machines;

a scanner associated with the route, the scanner located at a second physical location within the physical environment, and configured to scan the machine readable code; and

a production controller comprising:

a memory configured to store computer-executable instructions; and

at least one processor in communication with the memory, wherein the computer-executable instructions, when executed by the at least one processor, cause the at least one processor to:

receive object data associated with the item; instruct the printer to print a label comprising a machine readable code based at least in part on the object data;

receive, from the printer, first time data, wherein the first time data indicates a printing time of the label by the printer;

receive, from the scanner, production data, a scanner identifier, and item information, wherein the production data indicates 1) that the scanner scanned the machine readable code, and 2) a scanning time of the machine readable code by the scanner;

determine, based at least in part on the production data, the scanner identifier, and the item information, input data, wherein the input data indicates that the item was produced via the route, and a production time associated with the item, wherein the production time is based at least in part on the printing time and the scanning time;

determine performance data associated with the one or more machines based at least in part on the input data; and

instruct execution of a machine according to the performance data.

18. The system of claim 17, wherein to instruct execution of the machine, the computer-executable instructions, when executed by the at least one processor, further cause the at least one processor to:

generate at least one of a layout or a schedule based at least in part on the performance data; and

instruct the machine to output the at least one of the layout or the schedule.

19. The system of claim 17, wherein to instruct execution of the machine, the computer-executable instructions, when executed by the at least one processor, further cause the at least one processor to instruct the one or more machines to automatically perform one or more operations in a particular order.

20. A computer-implemented method comprising:

receiving first object data associated with an object;

instructing a first hardware device located at a first physical location within a physical environment to physically output a label comprising machine readable code based at least in part on the first object data, wherein the machine readable code is associated with the object;

receiving, from the first hardware device, first time data, wherein the first time data indicates an output time of the label by the first hardware device;

receiving, from a second hardware device associated with a first physical route through the physical environment and located at a second physical location within the physical environment, first production data, a second hardware device identifier, and second object data, wherein the second hardware device is configured to optically scan the machine readable code using a first image sensor, wherein the first physical route comprises a first route start, a first route end, and one or more first physical machines between the first route start and the first route end, wherein the first production data indicates 1) that the second hardware device scanned the machine readable code and 2) a scan time of the machine readable code by the second hardware device, and wherein the second hardware device identifier indicates the second physical location, wherein a third hardware device is associated with a second physical route through the physical environment and is located at a third physical location within the physical environment, the second physical route comprising a second route start, a second route end, and one or more second physical machines between the second route start and the second route end, wherein the third hardware device is configured to optically scan the machine readable code using a second image sensor;

determining, based at least in part on the first production data, the second hardware device identifier, and the second object data, input data, wherein the input data indicates that the object was produced via the first physical route, and a production time associated with the object, wherein the production time is based at least in part on the output time of the label and the scan time;

executing a machine learning model based at least in part on the input data, wherein the machine learning model predicts performance data associated with the one or more first physical machines based at least in part on the input data; and

instructing execution of a physical machine according to the performance data.