



US 20150034113A1

(19) **United States**
(12) **Patent Application Publication**
Yamagishi et al.

(10) **Pub. No.: US 2015/0034113 A1**
(43) **Pub. Date: Feb. 5, 2015**

(54) **ELECTRIC MAKEUP BRUSH**

(71) Applicant: **Shiseido Company, Ltd.**, Chuo-ku, Tokyo (JP)

(72) Inventors: **Toshimitsu Yamagishi**, Yokohama-shi (JP); **Kazuhisa Ohno**, Yokohama-shi (JP); **Mikiya Tanaka**, Yokohama-shi (JP); **Tomochika Fujioka**, Chuo-ku (JP); **Akihito Torii**, Yokohama-shi (JP); **Motoki Takata**, Yokohama-shi (JP)

(52) **U.S. Cl.**

CPC *A46B 13/023* (2013.01); *A45D 33/36* (2013.01); *A45D 34/042* (2013.01); *A45D 2033/001* (2013.01)
USPC **132/200**; 15/22.2

(57) **ABSTRACT**

(21) Appl. No.: **14/359,589**

(22) PCT Filed: **Nov. 19, 2012**

(86) PCT No.: **PCT/JP2012/079925**

§ 371 (c)(1),

(2) Date: **May 21, 2014**

(30) **Foreign Application Priority Data**

Nov. 21, 2011 (JP) 2011-253392

Publication Classification

(51) **Int. Cl.**

A46B 13/02 (2006.01)
A45D 34/04 (2006.01)
A45D 33/36 (2006.01)

An object of the present invention is to provide an electrically-operated makeup tool to enable, through electric operation, a motion different from makeup work performed by hand, an excellent finish of makeup relative to when performed by hand, and a comfortable feeling upon contact with the skin that has not been conventionally achievable, in addition to enabling application of powdered cosmetic material in a short period of time without dirtying the hand. Provided is a makeup brush that causes an applicator formed of bundled bristles to reciprocally vibrate in a direction in which the bristles are oriented with an electric drive unit such that the applicator dabs cosmetic material onto the skin with the tip of the bristles, wherein the amplitude of the reciprocal vibration is 2 to 10 mm, the vibration frequency of the reciprocal vibration is 3 to 50 Hz, and the length of the bristles is 15 to 30 mm.

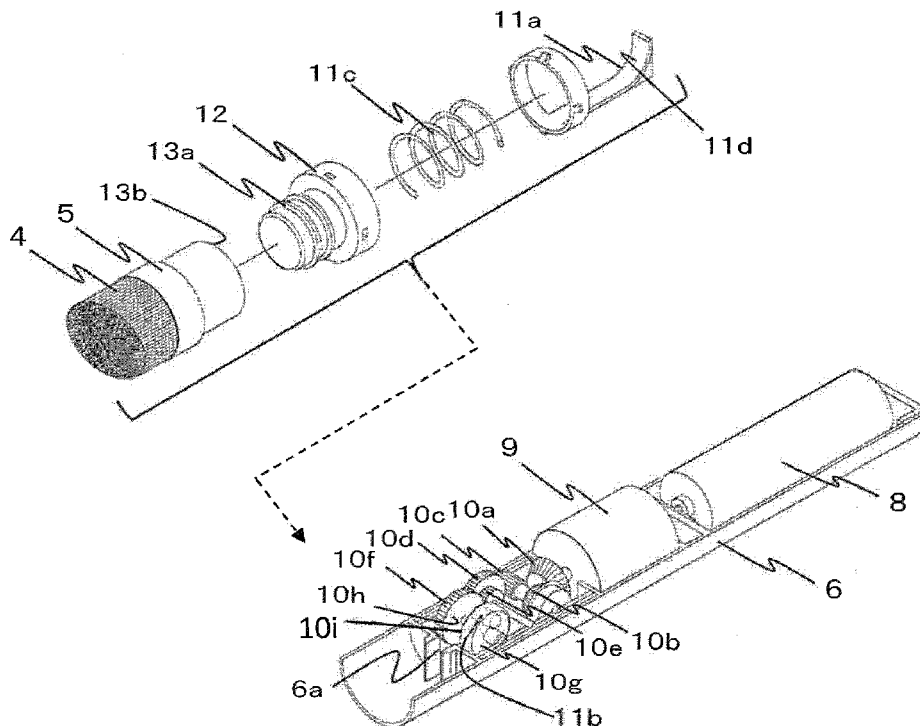

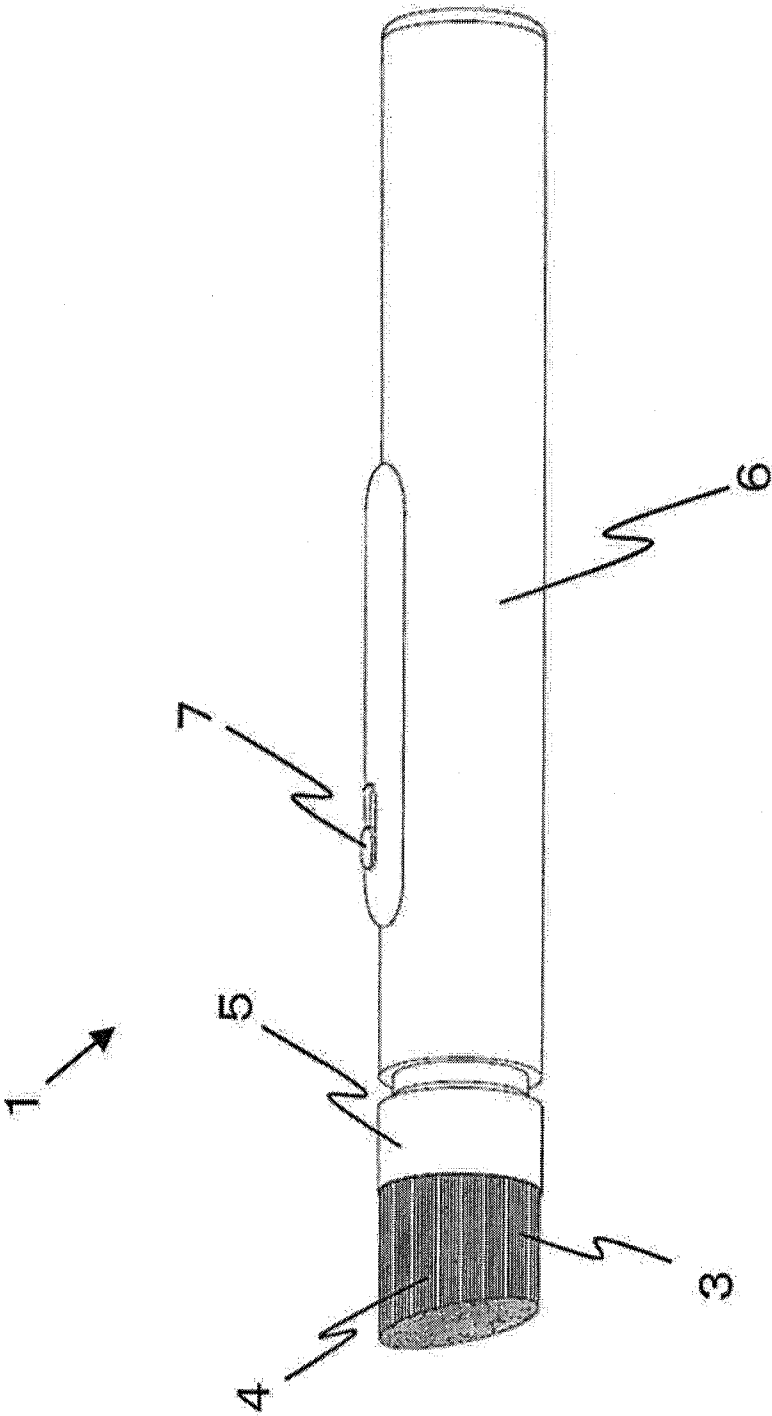

Fig.1

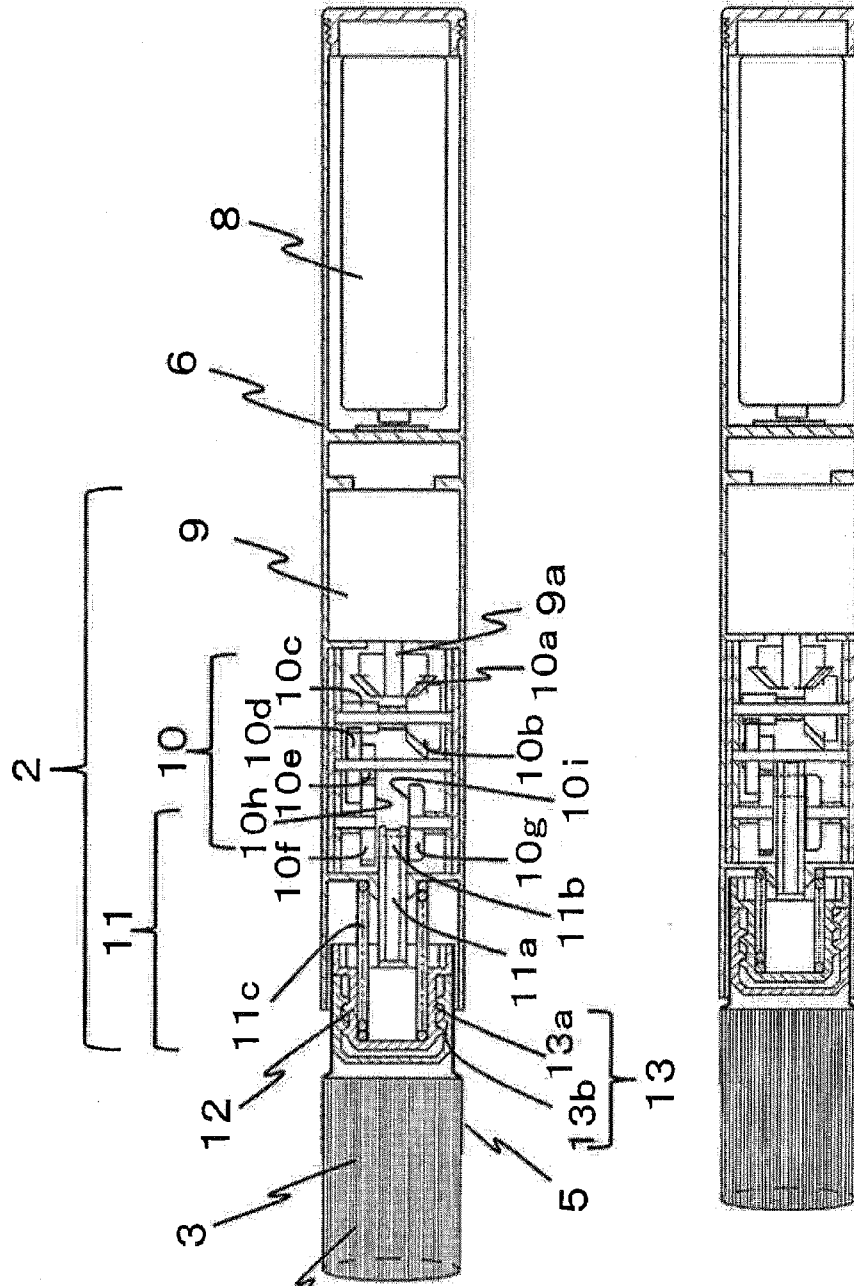
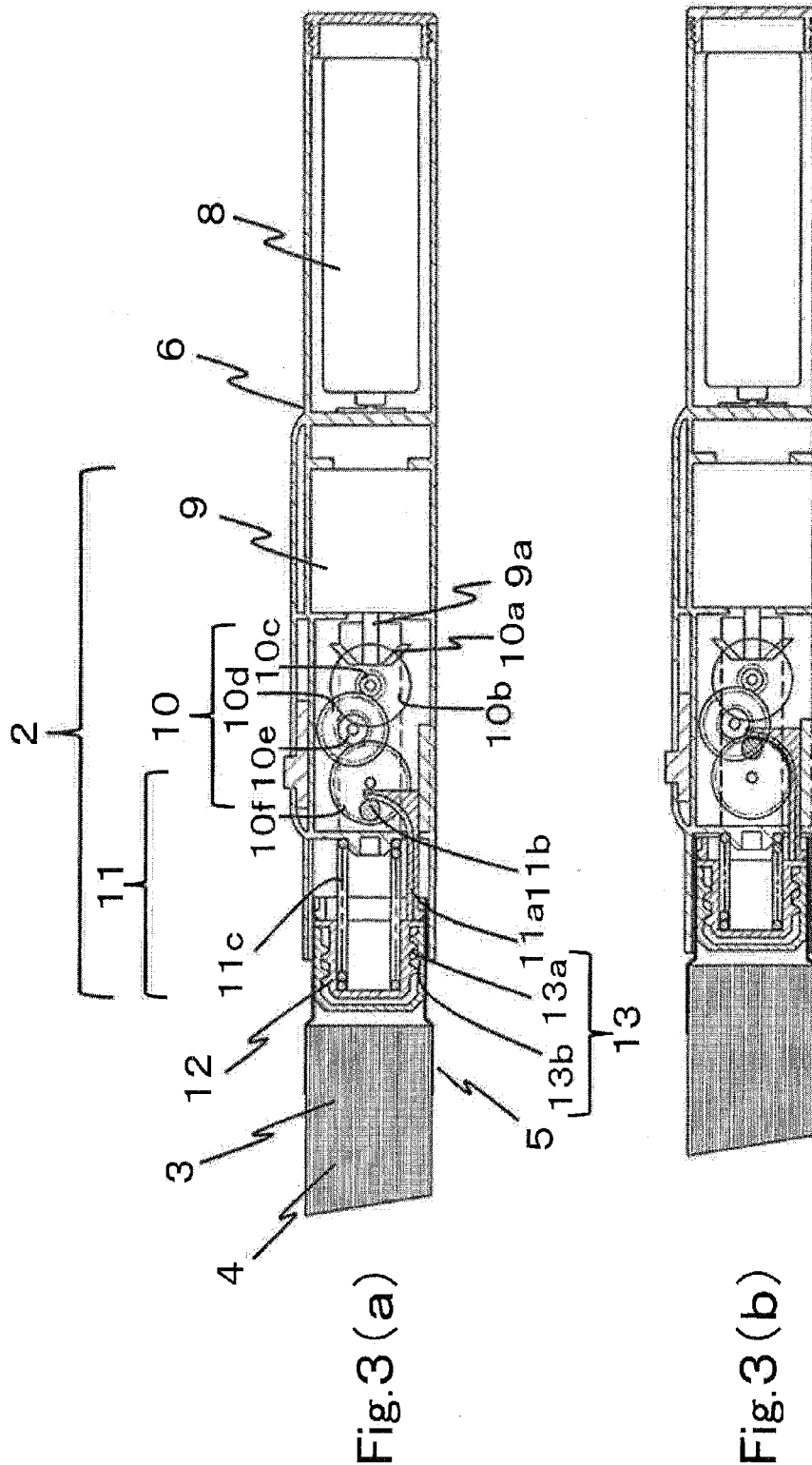
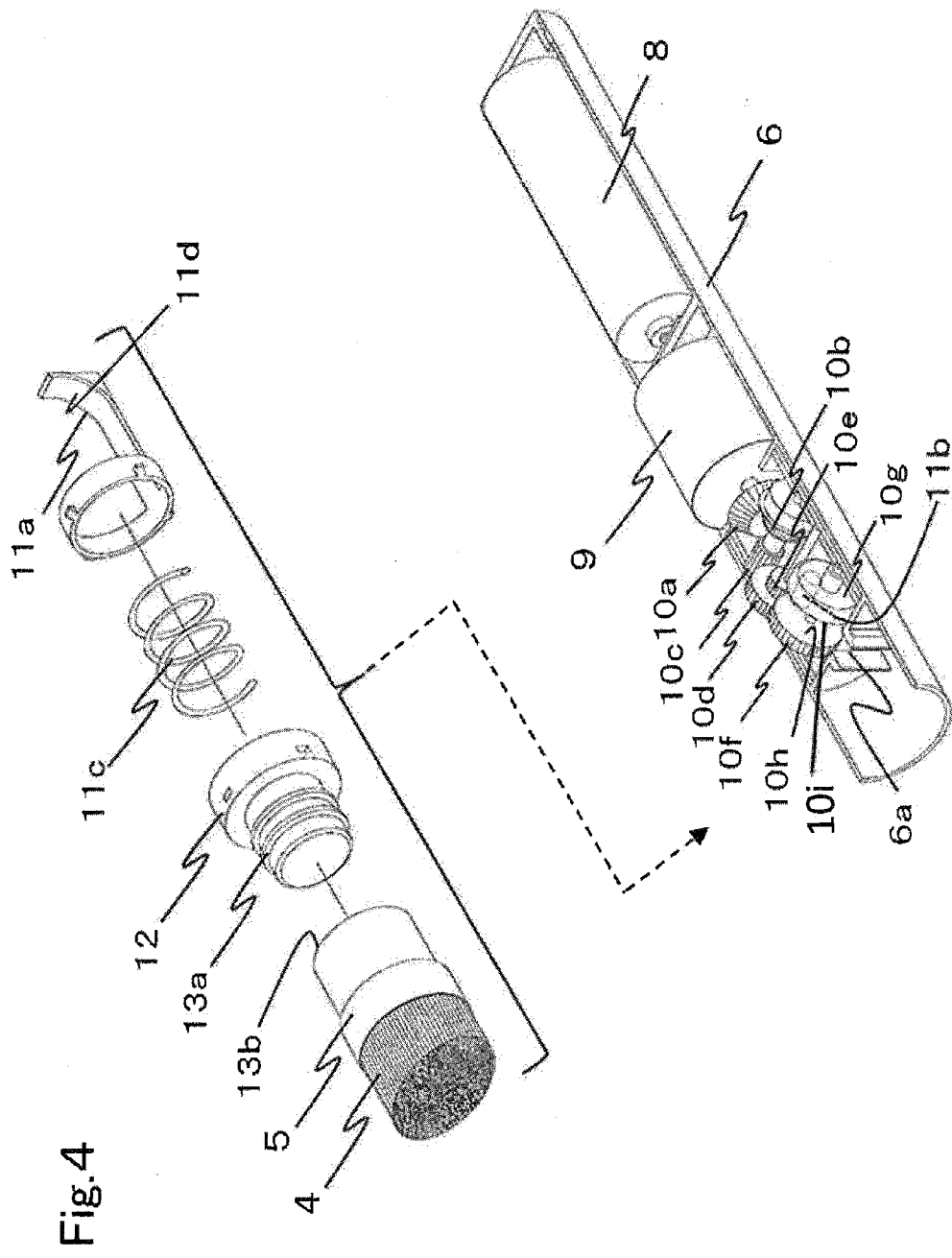

Fig. 2 (a)

Fig. 2 (b)





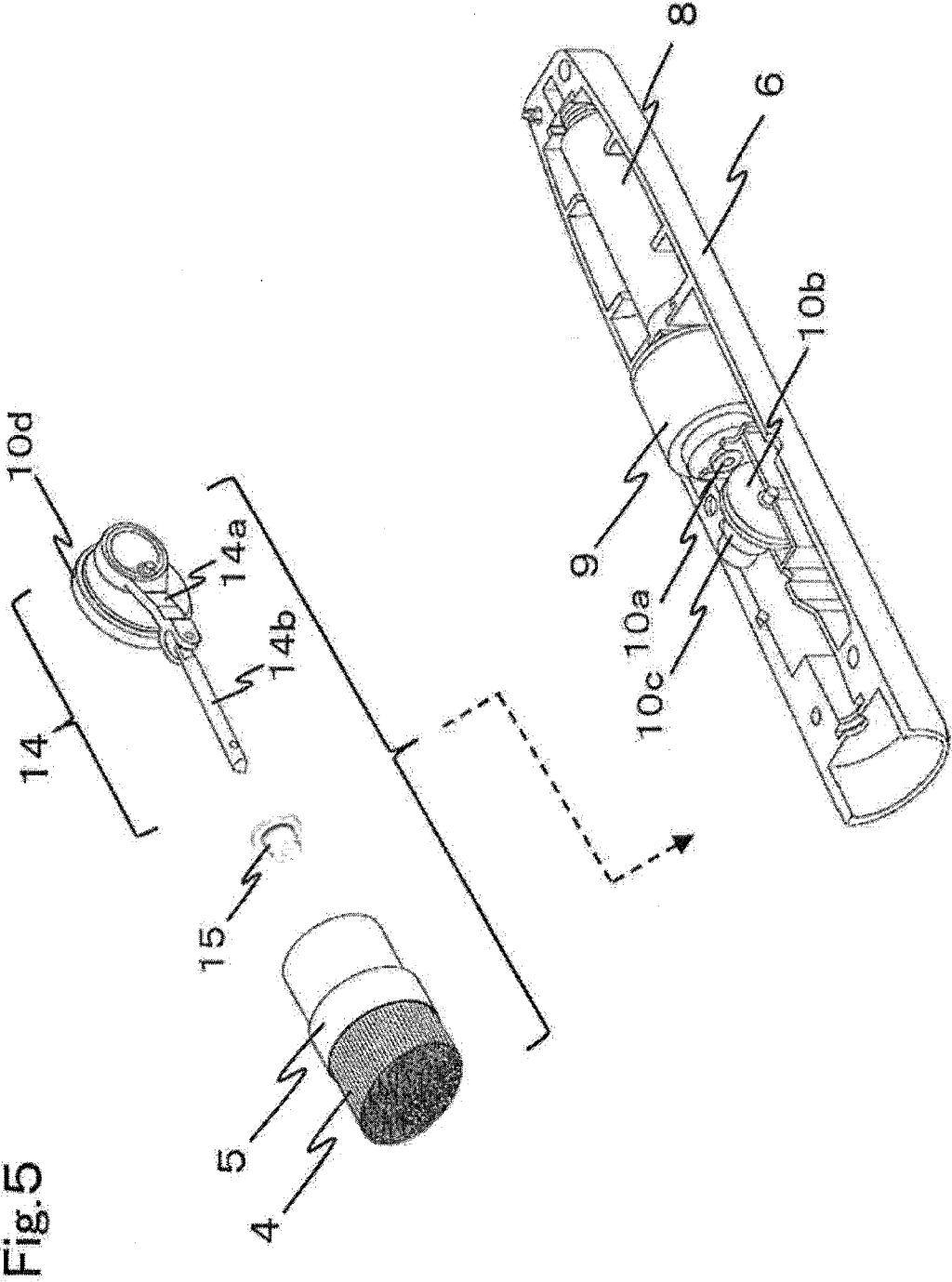

Fig.6 (c)

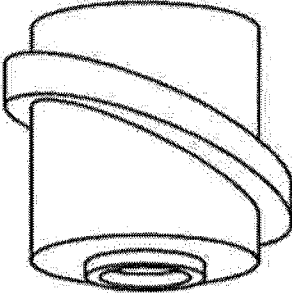

Fig.6 (b)

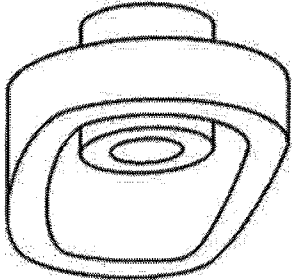

Fig.6 (a)

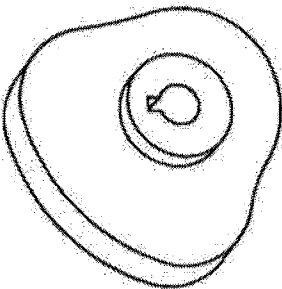

Fig.7 (a)

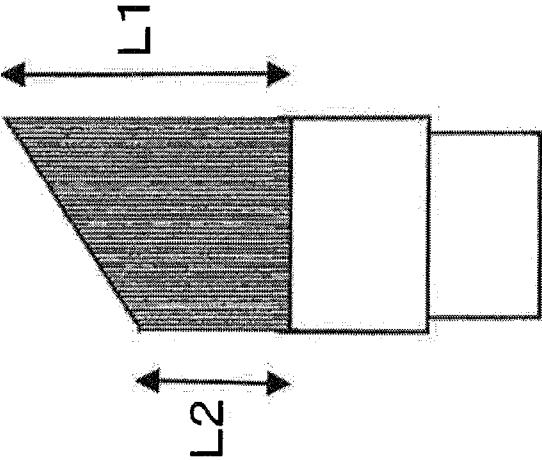

Fig.7 (b)

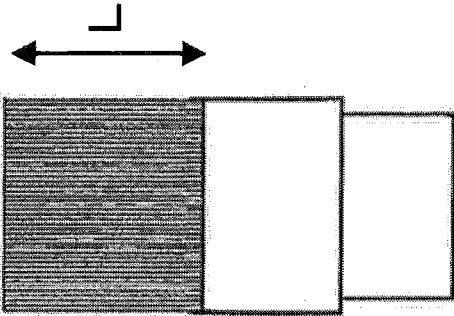
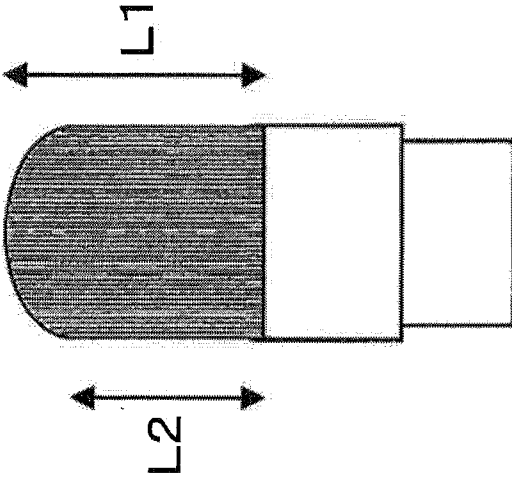

Fig.7 (c)



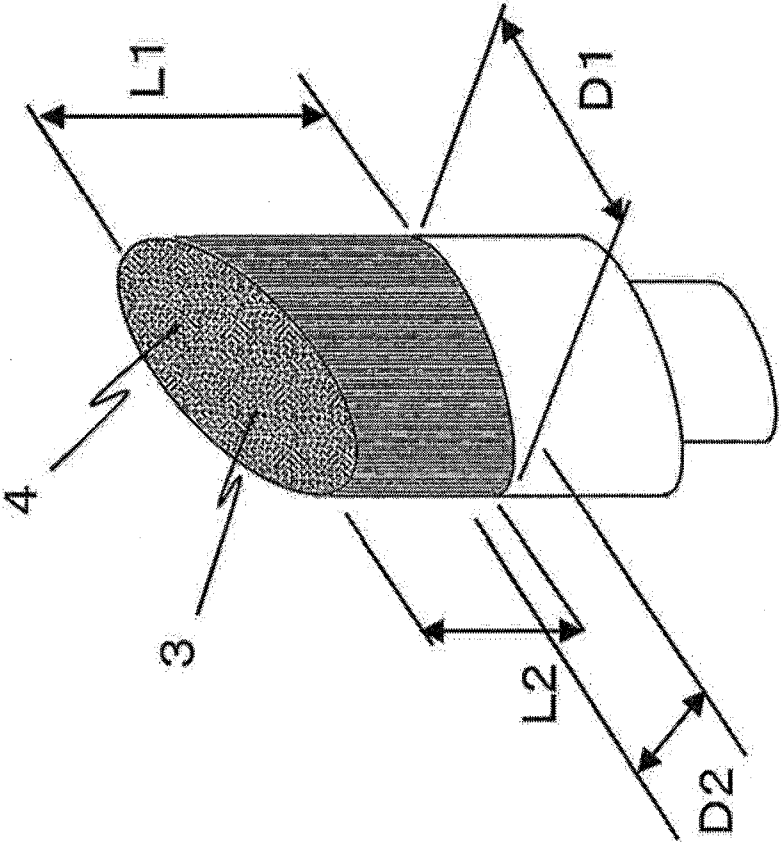
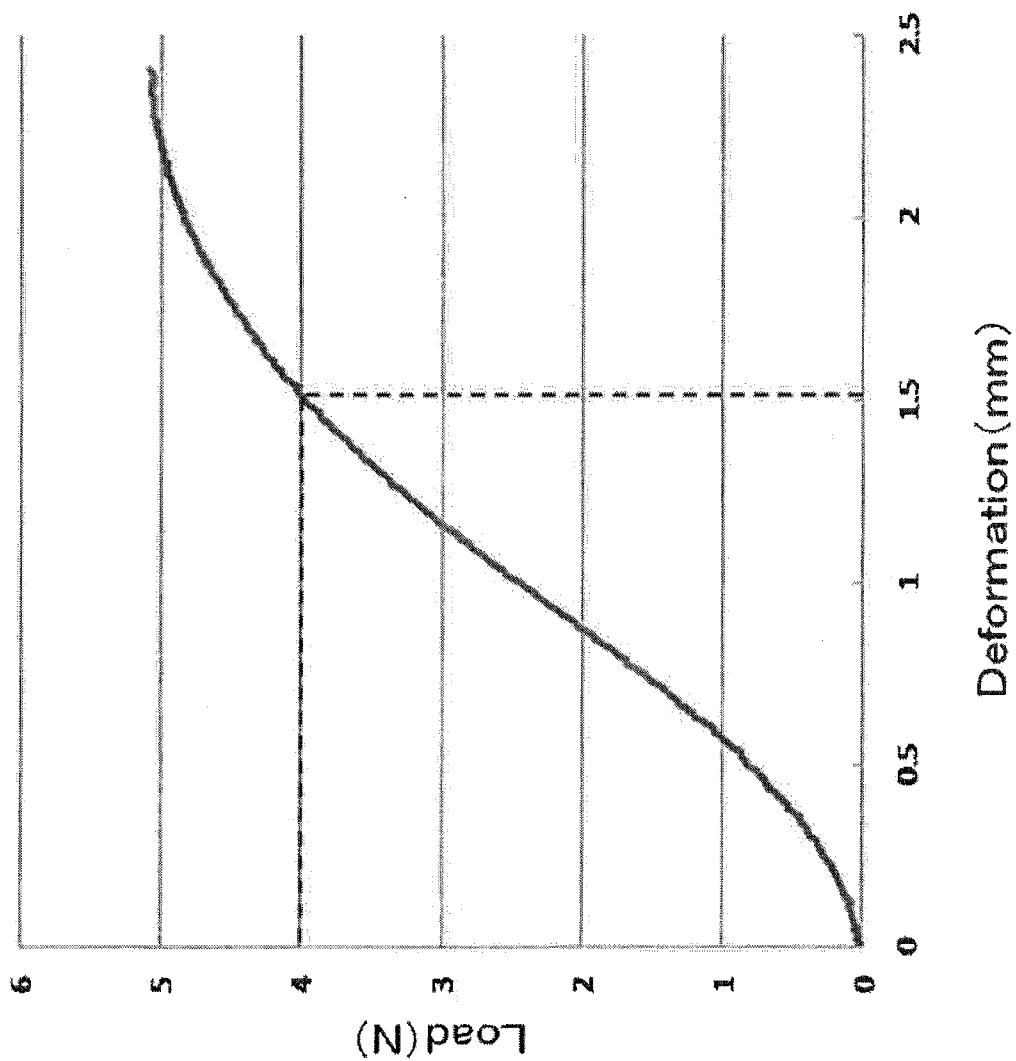

Fig.8

Fig. 9



ELECTRIC MAKEUP BRUSH

TECHNICAL FIELD

[0001] The present invention relates to an electric makeup brush that causes an applicator formed of bundled bristles to be reciprocally vibrated in a direction in which the bristles are oriented with an electric drive unit such that the applicator dabs cosmetic material onto the skin with the tip of the bristles.

BACKGROUND ART

[0002] Since powdered cosmetic materials such as foundation are applied to a relatively large area of skin, it is of importance to develop a makeup application tool that enables uniform application in a short period of time and an even and beautiful finish. Therefore, in recent years, electrically-operated makeup brushes as a makeup application tool for applying powdered cosmetic material such as foundation have been developed (Patent Documents 1 and 2).

[0003] These electrically-operated makeup brushes have an effect of enabling application without dirtying the hand in a shorter period of time than application by hand in a conventional manner and a massaging effect through an increase in blood circulation. However, the basic motions of the makeup brushes do not differ greatly from the motion conventionally performed by hand. Therefore, a significant effect in contrast to a case of application by hand has not been necessarily expectable in the finish of makeup.

[0004] Development is desired for an electrically-operated makeup tool to enable, through electric operation, a motion different from makeup work performed by hand, an excellent finish of makeup relative to when performed by hand, and an excellent feeling upon contact with the skin that has not been conventionally achievable, in addition to enabling reduction in time without dirtying the hand through electric operation.

[0005] Patent Document 1: Japanese Patent Application Laid-open No. 2006-192074

[0006] Patent Document 2: Japanese Patent Application Laid-open No. 2006-238998

DISCLOSURE OF THE INVENTION

[0007] An object of the present invention is to provide an electrically-operated makeup tool to enable, through electric operation, a motion different from makeup work performed by hand, an excellent finish of makeup relative to when performed by hand that has not been conventionally achievable, and a comfortable feeling upon contact with the skin, in addition to enabling application of powdered cosmetic material in a short period of time without dirtying the hand.

[0008] As a result a study conducted in order to achieve the above object, the inventors of the present invention have found that powdered cosmetic material can be applied uniformly in a short period of time without dirtying the hand with an excellent feeling upon contact with the skin and that an excellent cosmetic effect is obtained by causing an applicator formed of bundled bristles to be reciprocally vibrated in a direction in which the bristles are oriented with an electric drive unit such that the applicator dabs the cosmetic material onto the skin with the tip of the bristles.

[0009] That is, the present invention is an electric makeup brush that causes an applicator formed of bundled bristles to reciprocally vibrate in a direction in which the bristles are

oriented with an electric drive unit such that the applicator dabs cosmetic material onto a skin with the tip of the bristles.

[0010] Further, the present invention is the electric makeup brush wherein the drive unit includes an electric motor, a speed reduction mechanism for reducing rotation of the electric motor, and a reciprocating motion conversion mechanism that converts rotation reduced by the speed reduction mechanism into reciprocating motion.

[0011] Further, the present invention is the electric makeup brush wherein the reciprocating motion conversion mechanism includes a cam mechanism that converts rotation reduced by the speed reduction mechanism into reciprocating motion in a direction identical or orthogonal to a rotating shaft.

[0012] Further, the present invention is the electric makeup brush wherein the cam mechanism includes a push spring for biasing an arm to cause contact with a cam.

[0013] Also, the present invention is the electric makeup brush wherein the reciprocating motion conversion mechanism includes a crank mechanism that converts rotation reduced by the speed reduction mechanism into reciprocating motion in a direction orthogonal to a rotating shaft.

[0014] Further, the present invention is the electric makeup brush wherein an amplitude of the reciprocal vibration is 2 to 10 mm.

[0015] Further, the present invention is the electric makeup brush wherein a vibration frequency of the reciprocal vibration is 3 to 50 Hz.

[0016] Further, the present invention is the electric makeup brush wherein a length of each of the bristles is 15 to 30 mm.

[0017] Further, the present invention is the electric makeup brush wherein an outer diameter of the applicator is 10 to 35 mm.

[0018] Further, the present invention is the electric makeup brush wherein a tip surface of the applicator has a flat shape.

[0019] Further, the present invention is the electric makeup brush wherein a tip surface of the applicator has a flat shape inclined with respect to the direction in which the bristles are oriented.

[0020] Also, the present invention is a makeup method including using the electric makeup brush described above to dab cosmetic material onto a skin with the tip of the bristles.

[0021] With the electric makeup brush of the present invention, powdered cosmetic material such as foundation can be dabbed onto the skin with the tip of the bristles, and it is possible to obtain a makeup effect of a uniform and beautiful finish with excellent durability.

[0022] Feeling upon contact with the skin is excellent, and it is possible to apply powdered cosmetic material uniformly over the entire face in a short period of time without dirtying the hand.

BRIEF DESCRIPTION OF THE DRAWINGS

[0023] FIG. 1 is an external view of an electric makeup brush;

[0024] FIGS. 2(a) and 2(b) are transparent front views of the electric makeup brush (FIG. 2 (a) of a state where an applicator is projected, and FIG. 2(b) of a state where the applicator is drawn in);

[0025] FIGS. 3(a) and 3(b) are transparent side views of the electric makeup brush (FIG. 3 (a) of a state where an applicator is projected, and FIG. 3(b) of a state where the applicator is drawn in);

[0026] FIG. 4 is an exploded view of main components of the electric makeup brush;

[0027] FIG. 5 is an exploded view of main components of an electric makeup brush (of a second embodiment);

[0028] FIGS. 6(a) to 6(c) are shapes of a cam (FIG. 6(a) of the second embodiment, FIG. 6(b) of a third embodiment, and FIG. 6(c) of a fourth embodiment);

[0029] FIGS. 7(a) to 7(c) are views showing the shape of the applicator (FIG. 7(a) with an inclined flat surface, FIG. 7(b) with a perpendicular flat surface, and FIG. 7(c) with a curved surface);

[0030] FIG. 8 is a view showing a dimensional measurement portion of the applicator; and

[0031] FIG. 9 is a graph showing the relationship of the deformation amount and load of the applicator.

BEST MODE FOR CARRYING OUT THE INVENTION

[0032] An electric makeup brush of the present invention will be described in detail based on the drawings.

[0033] FIG. 1 shows the external appearance of the electric makeup brush of the present invention. When a switch (7) provided to a body (6) of an electric makeup brush (1) of the present invention is turned on, an electric drive unit built in the body (6) is activated to reciprocally vibrate an applicator (4) formed of bundled bristles (3) in a direction in which the bristles (3) are oriented, so that the applicator can dab cosmetic material onto the skin with the tip of the bristles.

[0034] For the material of the bristle, use of horsehair that has been conventionally used in makeup brushes or hair of an animal such as a weasel, gray squirrel, pine squirrel, Canadian squirrel, goat, raccoon, deer, cattle, sheep, rabbit, monkey, cat, fox, pig, wolf, or Japanese giant flying squirrel, use of a bristle of synthetic fiber such as polybutylene terephthalate (PET), polyethylene terephthalate (PET), or nylon, use of a blend thereof, and the like are acceptable.

[0035] There is a wide range of choice for the applicator without particular limitation, as long as the rigidity is approximately the same as that of a conventional makeup brush. However, when load is applied to the tip of the bristles to push and bend the applicator, the load for pushing and bending the applicator by 0 to 8 mm is preferably in a range of 0 to 10 N, so that there is excellent flexibility and an excellent fit and feeling on the skin. For the electric makeup brush of the present invention, it is particularly preferable that the deformation amount upon application of 4 N of load on the applicator is approximately 1.5 mm as shown in FIG. 9, for example, so that there is a favorable balance in the ease of application and touch on the skin from vibration.

[0036] As shown in FIGS. 2(a) and 2(b), a drive unit (2) includes an electric motor (9), a speed reduction mechanism (10) for reducing the rotation of the electric motor, and a reciprocating motion conversion mechanism (11) that converts rotation reduced by the speed reduction mechanism into reciprocating motion. A dry cell (8) is built in the body (6). When the switch (7) is turned on, the electric motor (9) is activated to activate the drive unit (2).

[0037] The speed reduction mechanism (10) is a mechanism for reducing the rotation of the electric motor (9) up to rotation of an appropriate rotation speed through use of the gear ratio of a plurality of gears. As shown in FIGS. 2(a) and 2(b) and FIGS. 3(a) and 3(b) (FIGS. 2(a) and 2(b) showing transparent views from the front and FIGS. 3(a) and 3(b) transparent views from the side), a first gear (10a) attached to

a rotating shaft (9a) of the electric motor (9) is engaged with a second gear (10b), and the rotation of the electric motor is transmitted to the second gear. In the drawing, the first gear (10a) and the second gear (10b) are bevel gears to convert the rotation of the electric motor (9) into rotation of a rotating shaft orthogonal to the rotating shaft (9a). Accordingly, the speed reduction mechanism (10) and the electric motor (9) can be aligned in the shaft center direction of the rotating shaft (9a) of the electric motor (9) to allow the body (6) to be in a rod shape that is excellent in portability.

[0038] A third gear (10c) is a gear with a smaller number of teeth and a smaller diameter than the second gear (10b) and is coupled with the same rotating shaft as the second gear (10b). The third gear (10c) is engaged with a fourth gear (10d) with a larger number of teeth and a larger diameter than the third gear. The gear ratio of the third gear and the fourth gear allows the rotation speed to be reduced. At the rotating shaft of the fourth gear (10d), a fifth gear (10e) with a small number of teeth and a small diameter is coupled. By the fifth gear (10e) engaging with a sixth gear (10f) with a larger number of teeth and a larger diameter, the rotation speed is further reduced. With the speed reduction mechanism (10), the rotation of the electric motor that is about 6000 rpm in rotation speed is eventually reduced to about 180 to 3000 rpm in rotation speed.

[0039] FIGS. 2(a), 2(b), 3(a) and 3(b) show the speed reduction mechanism (10) using six gears. This is for incorporation into the body (6) with a thin rod shape that is excellent in portability. By using and combining a plurality of gears that are relatively small in outer diameter to allow incorporation into the body (6), the rotation speed is reduced in a step-like manner. Note that since the shape of the body (6) differs depending on the usage or method of use of the electric makeup brush, the number or type of gears to be used in the speed reduction mechanism should be selected appropriately.

[0040] The reciprocating motion conversion mechanism (11) is a mechanism for converting rotation reduced by the speed reduction mechanism (10) into reciprocating motion. As shown in FIG. 4, the sixth gear (10f) and a rotating plate (10g) for which the rotating shaft is the same are coupled in a position eccentric from the rotating shaft of plate side surfaces (10h and 10i) that face each other by a contact pin (11b) arranged to be parallel to the rotating shaft.

[0041] An arm (11a) that contacts the contact pin (11b) upon rotation of the sixth gear (10f) is fixed to a vibrating member (12) through an insertion hole (6a) provided to the body (6). The arm (11a) has an inclined surface that is curved. This is a contact surface (11d) for contact with the contact pin (11b). Between the vibrating member (12) and the body (6), a push spring (11c) is incorporated and biased such that repulsion of the spring causes the arm (11a) to contact the contact pin (11b).

[0042] On the outer circumferential surface of the vibrating member (12), an external thread section (13a) is provided to be screwed into and coupled with an applicator holding body (5) provided with an internal thread section (13b) on the inner circumferential surface. At the applicator holding body (5), the applicator (4) in which bristles oriented in the vibrating direction of the vibrating member (12) are bundled is fixed on the opposite side of the vibrating member (12). The configuration is such that, when the vibrating member (12) vibrates reciprocally, the applicator (4) is caused to vibrate reciprocally in the direction in which the bristles (3) are oriented. Coupling of the vibrating member (12) and the applicator

holding body (5) by screwing is one example for detachably joining the applicator (4) and the applicator holding body (5) to the vibrating member (12), in case replacement of the applicator (4) becomes necessary due to wear of bristles or the like. Thus, a method other than screwing may be employed appropriately as a method for detachable joining. In the case where replacement of the applicator is not necessary, the vibrating member (12) and the applicator holding body (5) may be formed integrally.

[0043] FIGS. 2(a) and 2(b) are transparent views of the electric makeup brush of the present invention seen from the front, and FIGS. 3(a) and 3(b) are transparent views seen from the side. FIGS. 2(a) and 3(a) as well as FIGS. 2(b) and 3(b) respectively show corresponding states. FIGS. 3(a) and 3(b) show an example in which the sixth gear (10f) rotates in the counterclockwise direction. When the sixth gear (10f) rotates, the arm (11a) starts to contact the contact pin (11b) from the state of FIG. 3(a) (FIG. 2(a)). When the sixth gear (10f) rotates further in the counterclockwise direction, the arm (11a) moves in the right direction in the drawing along with the movement of the contact pin (11b). With an inclined surface that is curved as the contact surface for the contact pin and bias by the push spring (11c), the arm (11a) can follow the rotating motion of the contact pin (11b) smoothly, and the rotating motion of the sixth gear (10f) can be converted into reciprocating motion.

[0044] Along with the rotation of the sixth gear (10f), the arm (11a) moves in the right direction in the drawing up to the state of FIG. 3(b) (FIG. 2(b)). However, when the sixth gear (10f) rotates further, engagement with the contact pin (11b) is released, and the arm (11a) and the vibrating member (12) coupled therewith quickly moves in the left direction in the drawing due to repulsion by the push spring (11c). Along with this movement, the applicator (4) is projected for a dab on the skin with the tip of the bristles. In this manner, the repulsion of the push spring (11c) biases the arm (11a), causes the arm (11a) to contact the contact pin (11b), and, in the case where engagement of the arm (11a) and the contact pin (11b) is released, acts as a force for quickly moving the applicator (4) for a dab on the skin with the tip of the bristles. Since the force of the spring is used for a dab on the skin in this manner, a comfortable sense of use can be obtained without applying a strong force on the skin. Due to the push spring (11c) being incorporated, excess force is not transmitted to the sixth gear (10f) even in the case where a user presses the electric makeup brush against the skin with a strong force upon use, for example. Therefore, it is possible to avoid a risk of failure in the speed reduction mechanism (10) or the electric motor (9).

[0045] In the cam mechanism (11) in FIGS. 2(a), 2(b), 3(a), and 3(c), a cam is formed by coupling plate side surfaces (10h and 10i) of the sixth gear (10f) and the rotating plate (10g) that face each other with the contact pin (11b) parallel to the rotating shaft, and the arm (11a) that contacts the cam (contact pin (11b)) is combined to convert the rotating motion of the sixth gear (10f) into reciprocating motion in a direction orthogonal to the rotating shaft. However, the shape of the cam is not limited to that shown in the drawing. For example, a plate cam as shown in FIG. 6(a) may be attached to a rotating shaft of a gear for use. By using an end cam (FIG. 6(b)) or a cylindrical rib cam (FIG. 6(c)), it is possible to convert the rotating motion of the sixth gear (10f) into reciprocating motion in the same direction as the rotating shaft, and the direction in which the applicator vibrates can be changed.

[0046] The rotating motion of the gear (10f) can be converted into reciprocating motion in a direction orthogonal to the rotating shaft also by providing a crank mechanism (14) to the reciprocating motion conversion mechanism (11), as shown in FIG. 5. The crank mechanism is formed by coupling one end of a coupling rod (14a) in a position eccentric from the rotating shaft of the fourth gear (10d) and further coupling a rod (14b) rotatably to the other end of the coupling rod (14a). A bush (15) is a member for restricting the rod (14b) in the vibrating direction through insertion of the rod (14b) and reducing friction with the body (6) caused by the reciprocal vibration of the rod (14b).

[0047] As an approach of changing the vibration frequency, there is a method of changing the voltage applied to the electric motor or changing the pulse width through PWM control to change the rotation speed of the electric motor. Although not shown in the drawing, an adjustment dial or the like for changing the applied voltage or the like may be provided to the body (6) so that the rotation speed of the electric motor can be appropriately adjusted at the time of use by a user. The amplitude (stroke length) may be adjusted through a change in the moving distance of the arm (11a) or the coupling rod (14a) in the reciprocating motion by increasing the diameter of a rotating body such as the sixth gear (10f) shown in FIGS. 2(a) and 2(b) or the fourth gear (10d) shown in FIG. 5 that is immediately before the conversion of rotating motion into reciprocating motion, changing the shape of the contact surface for the arm in the case where a cam with a shape as shown in FIGS. 6(a) to 6(c) is used as a rotating body, or the like.

Example

[0048] The results of a test conducted in order to confirm the effect of the electric makeup brush of the present invention will be described below in detail.

[0049] The results of comparison of the electric makeup brush of the present invention with a conventional makeup method (method of applying foundation with a normal technique using a normal makeup brush) are shown in Table 1. The evaluations are all an average of questionnaire evaluations conducted upon application of foundation by three panelists and are indicated as Excellent, Good, Normal, or Bad.

[0050] For the shape of the tip of the applicator, three types of “inclined flat surface” (FIG. 7(a)) that is a flat surface inclined with respect to the direction in which the bristles are oriented, “perpendicular flat surface” (FIG. 7(b)) that is a flat surface perpendicular to the direction in which the bristles are oriented, and “curved surface” (FIG. 7(c)) for which the tips of the bristles are cut and aligned in a mound shape were evaluated.

[0051] The length of the bristles is a value of measurement for a longest bristle length L1 and a shortest bristle length L2 for “inclined flat surface” (FIG. 7(a)), a bristle length L for “perpendicular flat surface” (FIG. 7(b)), and the longest bristle length L1 and the shortest bristle length L2 for “curved surface” (FIG. 7(c)).

[0052] The outer diameter of the applicator is a value of measurement for the outer diameter of the bundled bristles or of measurement of a major axis D1 and a minor axis D2 in the case of an elliptical shape (FIG. 8).

TABLE 1

Condition and evaluation item		Comparative Example 1 (conventional makeup method)	Example 1	Example 2	Example 3	Example 4	Example 5
Characteristics of brush	Shape of tip of applicator	Inclined flat surface	Inclined flat surface	Inclined flat surface	Perpendicular flat surface	Perpendicular flat surface	Curved surface
	Length of bristle (mm)	18-15	18-15	20-16	18	15	20-30
	Outer diameter of applicator (mm)	20	20	20-10	20	28-17	23
Characteristics of vibration	Vibration frequency (times per minute)	—	1200	1200	1200	1200	1200
	Stroke (mm)	—	3	3	3	3	3
Evaluation item	Sense of use	Normal	Excellent	Excellent	Good	Good	Excellent
	Capability for quick finish	Normal	Excellent	Excellent	Excellent	Excellent	Excellent
	Applicability to fine portions	Normal	Good	Excellent	Good	Good	Good
	Beauty of finish	Normal	Good	Good	Good	Good	Normal
Overall rating		Normal	Excellent	Excellent	Good	Good	Good

[0053] As shown in Table 1, favorable results were obtained for all of Examples 1 to 5 compared to the conventional makeup method (comparative example 1) using a normal makeup brush. Particularly for Examples 1 and 2 in which the shape of the tip of the applicator is “inclined flat surface,” high evaluations were obtained due to the applicability to fine portions. Thus, it was confirmed that a cosmetic effect is further enhanced by causing the shape of the tip of the applicator to be an inclined flat shape. When the outer diameter of the applicator exceeds 35 mm, it is difficult to apply cosmetic material to fine portions, and the beauty of finish is affected. Thus, the outer diameter of the applicator is preferably 35 mm or less.

[0054] Next, the sense of use such as the feeling of the applicator upon contact with the skin in the case where the vibration frequency and the stroke length (amplitude) of the electric makeup brush are changed were evaluated.

[0055] The shape of the applicator of the electric makeup brush for each evaluation is as shown in FIG. 7(a). The applicator used is cylinder-shaped with an outer diameter of 20 mm, a flat inclined surface as the tip surface, 18 mm in length (L1) for a longer bristle, and 15 mm in length (L2) for a shorter bristle.

TABLE 2

Sense of use (feeling and softness on the skin)							
Vibration frequency	Stroke (mm)						
	(Times per minute)	(Hz)	2	3	5	7	10
200	3.3	Good	Good	Good	Good	Good	Good
400	6.7	Good	Excellent	Good	Good	Good	Good
600	10	Good	Excellent	Good	Excellent	Good	Good
800	13.3	Good	Excellent	Excellent	Excellent	Good	Good
1200	20	Excellent	Excellent	Excellent	Excellent	Excellent	Excellent
2500	41.7	Good	Good	Good	Good	Good	Good

[0056] As shown in Table 2, the electric makeup brush of the present invention has a soft touch on the skin, and favor-

able results were confirmed with evaluation results of Excellent to Good under all conditions. Note that when the stroke length (amplitude) is less than 2 mm, the moving distance of the applicator is slight. Therefore, vibration was absorbed by the deformation of skin or bristle, the tip of the bristles did not come off the skin, and the effect of the present invention that is application through dabbing on the skin was not obtained sufficiently.

[0057] When the vibration frequency exceeds 50 Hz, vibration of the applicator was not felt, and the effect of application through dabbing on the skin with the tip of the bristles was not obtained.

[0058] Next, the results of evaluation for beauty of finish are shown in Table 3.

TABLE 3

Beauty of finish							
Vibration frequency	Stroke (mm)						
	(Times per minute)	(Hz)	2	3	5	7	10
200	3.3	Good	Good	Normal	Normal	Normal	Normal
400	6.7	Good	Good	Good	Normal	Normal	Normal
600	10	Good	Good	Good	Good	Good	Good
800	13.3	Good	Good	Excellent	Excellent	Good	Good
1200	20	Good	Good	Excellent	Excellent	Excellent	Excellent
2500	41.7	Good	Excellent	Excellent	Excellent	Excellent	Excellent

[0059] As shown in Table 3, there are many favorable results of Good distributed in a range of 2 to 10 mm in stroke length and 3.3 to 41.7 Hz in vibration frequency. Particularly, there are many extremely favorable results of Excellent distributed in a range of 13.3 to 41.7 Hz in vibration frequency and 3 to 7 mm in stroke length. Note that, with a vibration frequency exceeding 50 Hz, the motion of dabbing on the skin with the tip of the bristles cannot be performed reliably, and a favorable result was not obtained.

[0060] The results of evaluation for the effect of enabling a quick finish of makeup are shown in FIG. 4.

TABLE 4

Capability for quick finish						
Vibration frequency		Stroke (mm)				
(Times per minute)	(Hz)	2	3	5	7	10
200	3.3	Good	Normal	Normal	Normal	Normal
400	6.7	Good	Good	Good	Normal	Normal
600	10	Good	Good	Excellent	Good	Good
800	13.3	Good	Good	Excellent	Excellent	Good
1200	20	Excellent	Excellent	Excellent	Excellent	Excellent
2500	41.7	Good	Excellent	Excellent	Excellent	Excellent

[0061] For the effect of enabling a quick finish of makeup, as shown in Table 4, there are many favorable results of Good distributed in a range of 2 to 10 mm in stroke length and 3.3 to 41.7 Hz in vibration frequency. Particularly, there are many extremely favorable results of Excellent distributed in a range of 13.3 to 41.7 Hz in vibration frequency and 3 to 7 mm in stroke length. In this manner, it was confirmed that a region of a relatively large vibration frequency tends to be advantageous in the finish of makeup. When the vibration frequency is smaller than 3 Hz, makeup cannot be finished quickly. The vibration frequency is preferably 3 Hz or greater.

[0062] The results of evaluation for ease of application to fine portions are shown in Table 5.

TABLE 5

Applicability to fine portions						
Vibration frequency		Stroke (mm)				
(Times per minute)	(Hz)	2	3	5	7	10
200	3.3	Good	Good	Good	Good	Normal
400	6.7	Good	Good	Good	Good	Normal
600	10	Good	Good	Good	Good	Normal
800	13.3	Good	Good	Good	Good	Normal
1200	20	Good	Good	Good	Good	Normal
2500	41.7	Good	Good	Good	Good	Normal

[0063] For the ease of application to fine portions, as shown in Table 5, the results were favorable at Good with 2 to 7 mm in stroke length and ordinary at Normal with 10 mm. A normal or greater effect can be obtained with a stroke length of 2 to 10 mm. For application to fine portions, the stroke length is preferably 2 to 7 mm.

[0064] The overall evaluations summarizing the respective evaluations above are shown in Table 6.

TABLE 6

Overall rating						
Vibration frequency		Stroke (mm)				
(Times per minute)	(Hz)	2	3	5	7	10
200	3.3	Good	Good	Normal	Normal	Normal
400	6.7	Good	Good	Good	Normal	Normal

TABLE 6-continued

Overall rating						
Vibration frequency		Stroke (mm)				
(Times per minute)	(Hz)	2	3	5	7	10
600	10	Good	Good	Good	Good	Good
800	13.3	Good	Good	Excellent	Excellent	Good
1200	20	Excellent	Excellent	Excellent	Excellent	Excellent
2500	41.7	Good	Excellent	Excellent	Excellent	Good

[0065] As shown in Table 6, there are many favorable results of Good distributed in a range of 2 to 10 mm in stroke length and 3.3 to 41.7 Hz in vibration frequency. Particularly, there are many extremely favorable results of Excellent distributed in a range of 13.3 to 41.7 Hz in vibration frequency and 2 to 10 mm in stroke length. Note that the results above are evaluations for a case where foundation is applied. It is possible that evaluations differ from those described above in the case of applying powdered cosmetic material such as oshiroi or blush that differs in formula from foundation. Therefore, for application of various powdered cosmetic materials with the electric makeup brush, it is desirable that a mechanism capable of adjusting the stroke length and vibration frequency be provided. Upon applying foundation, use with an appropriate adjustment within the range described above is preferable.

EXPLANATION OF REFERENCE NUMERALS

- [0066] 1 Electric makeup brush
- [0067] 2 Drive unit
- [0068] 3 Bristle
- [0069] 4 Applicator
- [0070] 5 Applicator holding body
- [0071] 6 Body
- [0072] 6a Insertion hole
- [0073] 7 Switch
- [0074] 8 Dry cell
- [0075] 9 Electric motor
- [0076] 9a Rotating shaft
- [0077] 10 Speed reduction mechanism
- [0078] 10a First gear
- [0079] 10b Second gear
- [0080] 10c Third gear
- [0081] 10d Fourth gear
- [0082] 10e Fifth gear
- [0083] 10f Sixth gear
- [0084] 10g Rotating plate
- [0085] 10h Plate side surface
- [0086] 10i Plate side surface
- [0087] 11 Cam mechanism (reciprocating motion conversion mechanism)
- [0088] 11a Arm
- [0089] 11b Contact pin
- [0090] 11c Push spring
- [0091] 11d Contact surface
- [0092] 12 Vibrating member
- [0093] 13 Screwing section
- [0094] 13a External thread section

- [0095] 13*b* Internal thread section
 [0096] 14 Crank mechanism (reciprocating motion conversion mechanism)
 [0097] 14*a* Coupling rod
 [0098] 14*b* Rod
 [0099] 15 Bush

1. An electric makeup brush that causes an applicator formed of bundled bristles to reciprocally vibrate in a direction in which the bristles are oriented with an electric drive unit such that the applicator dabs cosmetic material onto a skin with the tip of the bristles.

2. The electric makeup brush according to claim 1, wherein the drive unit includes an electric motor, a speed reduction mechanism for reducing rotation of the electric motor, and a reciprocating motion conversion mechanism that converts rotation reduced by the speed reduction mechanism into reciprocating motion.

3. The electric makeup brush according to claim 2, wherein the reciprocating motion conversion mechanism includes a cam mechanism that converts rotation reduced by the speed reduction mechanism into reciprocating motion in a direction identical or orthogonal to a rotating shaft.

4. The electric makeup brush according to claim 3, wherein the cam mechanism includes a push spring for biasing an arm to cause contact with a cam.

5. The electric makeup brush according to claim 2, wherein the reciprocating motion conversion mechanism includes a crank mechanism that converts rotation reduced by the speed reduction mechanism into reciprocating motion in a direction orthogonal to a rotating shaft.

6. The electric makeup brush according to claim 1, wherein an amplitude of the reciprocal vibration is 2 to 10 mm.

7. The electric makeup brush according to claim 1, wherein a vibration frequency of the reciprocal vibration is 3 to 50 Hz.

8. The electric makeup brush according to claim 1, wherein a length of each of the bristles is 15 to 30 mm.

9. The electric makeup brush according to claim 1, wherein an outer diameter of the applicator is 10 to 35 mm.

10. The electric makeup brush according to claim 1, wherein a tip surface of the applicator has a flat shape.

11. The electric makeup brush according to claim 1, wherein a tip surface of the applicator has a flat shape inclined with respect to the direction in which the bristles are oriented.

12. A makeup method, comprising using the electric makeup brush according to claim 1 to dab cosmetic material onto a skin with the tip of the bristles.

13. The electric makeup brush according to claim 2, wherein an amplitude of the reciprocal vibration is 2 to 10 mm.

14. The electric makeup brush according to claim 3, wherein an amplitude of the reciprocal vibration is 2 to 10 mm.

15. The electric makeup brush according to claim 2, wherein a vibration frequency of the reciprocal vibration is 3 to 50 Hz.

16. The electric makeup brush according to claim 3, wherein a vibration frequency of the reciprocal vibration is 3 to 50 Hz.

17. The electric makeup brush according to claim 2, wherein a length of each of the bristles is 15 to 30 mm.

18. The electric makeup brush according to claim 2, wherein an outer diameter of the applicator is 10 to 35 mm.

19. The electric makeup brush according to claim 2, wherein a tip surface of the applicator has a flat shape.

20. The electric makeup brush according to claim 2, wherein a tip surface of the applicator has a flat shape inclined with respect to the direction in which the bristles are oriented.

* * * * *