

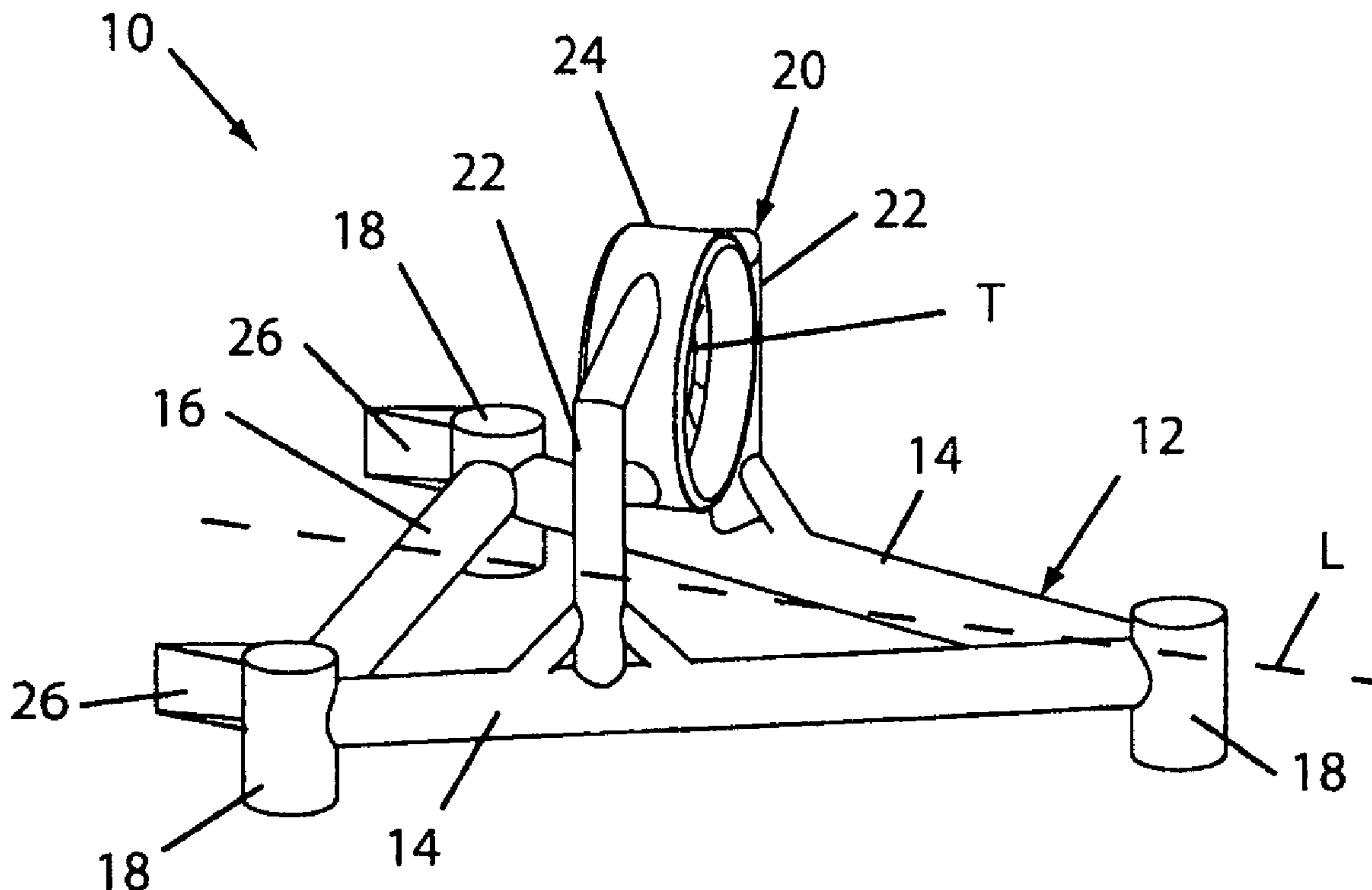

(86) Date de dépôt PCT/PCT Filing Date: 2009/12/14
 (87) Date publication PCT/PCT Publication Date: 2010/06/24
 (45) Date de délivrance/Issue Date: 2017/04/25
 (85) Entrée phase nationale/National Entry: 2011/06/13
 (86) N° demande PCT/PCT Application No.: EP 2009/008944
 (87) N° publication PCT/PCT Publication No.: 2010/069539
 (30) Priorité/Priority: 2008/12/18 (EP08021993.4)

(51) Cl.Int./Int.Cl. *F03B 13/26* (2006.01),
F03B 17/06 (2006.01)
 (72) Inventeurs/Inventors:
IVES, JAMES, IE;
DUNNE, PAUL, IE
 (73) Propriétaire/Owner:
OPENHYDRO IP LIMITED, IE
 (74) Agent: SIM & MCBURNEY

(54) Titre : TURBINE HYDROELECTRIQUE DOTEE D'UN MOYEN D'ALIGNEMENT ET PROCEDE DE DEPLOIEMENT
 (54) Title: A HYDROELECTRIC TURBINE SYSTEM WITH ALIGNING MEANS



(57) Abrégé/Abstract:

The present invention is concerned with a hydroelectric turbine system with aligning means which enables a hydroelectric turbine system, comprising a base and a turbine mounted thereon, to be lowered to the seabed in a running tide while effecting and maintaining stability and a desired orientation of the system.

(12) INTERNATIONAL APPLICATION PUBLISHED UNDER THE PATENT COOPERATION TREATY (PCT)

(19) World Intellectual Property Organization
International Bureau(43) International Publication Date
24 June 2010 (24.06.2010)

PCT

(10) International Publication Number
WO 2010/069539 A1

(51) International Patent Classification:

F03B 13/26 (2006.01) *F03B 17/06* (2006.01)

(21) International Application Number:

PCT/EP2009/008944

(22) International Filing Date:

14 December 2009 (14.12.2009)

(25) Filing Language:

English

(26) Publication Language:

English

(30) Priority Data:

08021993.4 18 December 2008 (18.12.2008) EP

(71) Applicant (for all designated States except US): **OPEN-HYDRO IP LIMITED** [IE/IE]; South Dock House, Hanover Quay, Dublin 2 (IE).

(72) Inventors; and

(75) Inventors/Applicants (for US only): **IVES, James** [GB/IE]; South Dock House, Hanover Quay, Dublin 2 (IE). **DUNNE, Paul** [IE/IE]; 12 Homefarm Park, Drumcondra, Dublin 9 (IE).(74) Agents: **O'NEILL, Brian** et al.; FRKelly, 27 Clyde Road, Ballsbridge, Dublin 4 (IE).

(81) Designated States (unless otherwise indicated, for every kind of national protection available): AE, AG, AL, AM, AO, AT, AU, AZ, BA, BB, BG, BH, BR, BW, BY, BZ, CA, CH, CL, CN, CO, CR, CU, CZ, DE, DK, DM, DO, DZ, EC, EE, EG, ES, FI, GB, GD, GE, GH, GM, GT, HN, HR, HU, ID, IL, IN, IS, JP, KE, KG, KM, KN, KP, KR, KZ, LA, LC, LK, LR, LS, LT, LU, LY, MA, MD, ME, MG, MK, MN, MW, MX, MY, MZ, NA, NG, NI, NO, NZ, OM, PE, PG, PH, PL, PT, RO, RS, RU, SC, SD, SE, SG, SK, SL, SM, ST, SV, SY, TJ, TM, TN, TR, TT, TZ, UA, UG, US, UZ, VC, VN, ZA, ZM, ZW.

(84) Designated States (unless otherwise indicated, for every kind of regional protection available): ARIPO (BW, GH, GM, KE, LS, MW, MZ, NA, SD, SL, SZ, TZ, UG, ZM, ZW), Eurasian (AM, AZ, BY, KG, KZ, MD, RU, TJ, TM), European (AT, BE, BG, CH, CY, CZ, DE, DK, EE, ES, FI, FR, GB, GR, HR, HU, IE, IS, IT, LT, LU, LV, MC, MK, MT, NL, NO, PL, PT, RO, SE, SI, SK, SM, TR), OAPI (BF, BJ, CF, CG, CI, CM, GA, GN, GQ, GW, ML, MR, NE, SN, TD, TG).

Published:

— with international search report (Art. 21(3))

(54) Title: A HYDROELECTRIC TURBINE WITH ALIGNING MEANS AND METHOD OF DEPLOYMENT

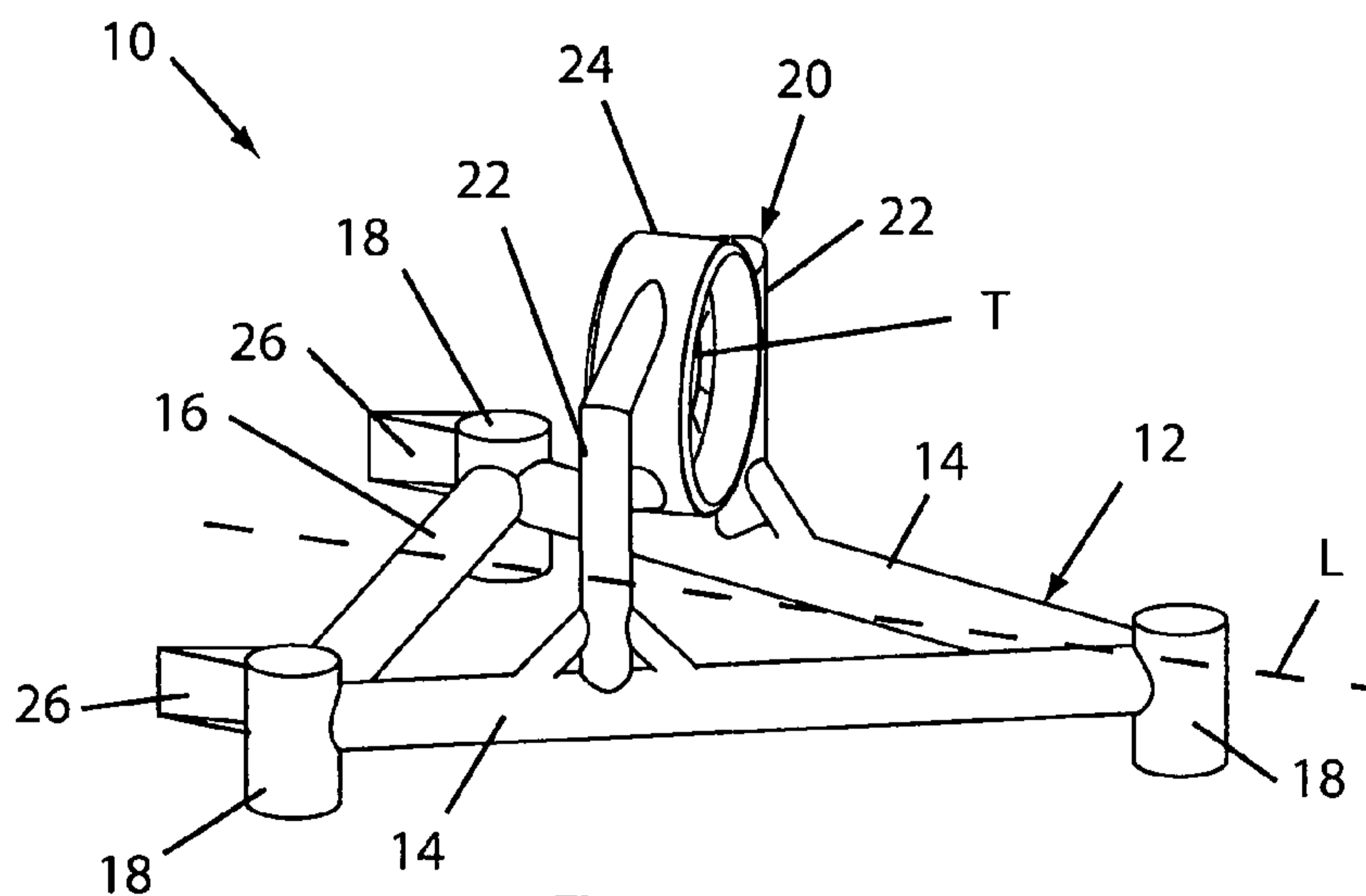

Figure 1

(57) Abstract: The present invention is concerned with a hydroelectric turbine system with aligning means which enables a hydroelectric turbine system, comprising a base and a turbine mounted thereon, to be lowered to the seabed in a running tide while effecting and maintaining stability and a desired orientation of the system.

WO 2010/069539 A1

A hydroelectric turbine system with aligning meansField of the invention

5

The present invention relates to a hydroelectric turbine system, in particular a system comprising a hydroelectric turbine mounted on a base, the system including means to stabilising and/or orient the system while being lowered, during a running tide, towards a deployment site on the seabed.

10

Background of the invention

15 Currently, and at a global scale, there is great concern surrounding the damage that the emission of CO₂ is causing to our environment, in particular the threat posed by global warming. One of the major sources of CO₂ emission is in the production of electricity, on a large scale, through the burning of fossil fuels. Electricity is however a commodity that has become essential to the survival of the human race, and there are thus vast resources currently being expended in seeking alternative means of generating large quantities of
20 electricity without the use of fossil fuel. While nuclear energy is one such alternative, most societies are uncomfortable with the negative aspects of nuclear power and thus other more desirable solutions are required.

25 Renewable energy has thus come to the fore in recent years, with many projects being developed around solar energy, wind energy, and tidal power. Of these alternative forms of energy, tidal power is arguably the most attractive, given that tidal flows are entirely predictable and constant, unlike wind or solar energy which are relatively intermittent and therefore less dependable.

30 However, harnessing tidal energy does provide its own challenges, in particular with respect to the installation and maintenance of tidal power generators, for example hydroelectric turbines, which by the very nature of the operation of same must be located in relatively fast flowing tidal currents, and more than likely located on the seabed. These conditions are significantly inhospitable, and are not conducive to safe working conditions. The

installation of a base on which such tidal turbines are mounted has conventionally taken the form of the sinking of a pile into the seabed, on which pile a turbine or secondary frame carrying one or more turbines can then be located. However, the sinking of a pile into the seabed in an area of high tidal flow is considerably problematic and generally a dangerous
5 operation. In addition, significant drilling and piling equipment must be transported to and operated at the site of installation, significantly increasing the complexity and cost of the operation.

10 Summary of the invention

According to a first aspect of the present invention there is provided a hydroelectric turbine system comprising a base and means for aligning the base into a desired orientation with respect to, and while suspended in, a tidal flow.

15

Preferably, the aligning means is passive.

Preferably, the aligning means comprises at least one fin.

20 Preferably, the aligning means comprises a plurality of fins.

Preferably, the base comprises a plurality of legs on which the base stands when on the seabed, at least one of the legs having at least one fin extending therefrom.

25 Preferably, the aligning means are arranged to effect displacement of the base into a desired orientation with respect to, and while suspended in, the tidal flow.

Preferably, the base comprises a mount which is shaped and dimensioned to retain a hydroelectric turbine.

30

Preferably, the system comprises a hydroelectric turbine mounted on the base.

Preferably, the aligning means is arranged to orient the system such that the turbine is operatively aligned with the direction of the tidal flow.

According to a second aspect of the present invention there is provided a method of deploying, in a running tide, a hydroelectric turbine system, the method comprising the steps of:

5 positioning a deployment vessel and the system above a deployment site; lowering the system from the vessel towards the deployment site; utilising the tidal flow of water past the system to achieve and/or maintain a desired orientation of the system with respect to the tidal flow.

Preferably, the method comprises utilising the tidal flow of water past the system to effect and/or maintain stability of the system in the tidal flow.

10 Preferably, the method comprises, in the step of lowering the system, utilising lowering means which permit the system to be displaced into a desired orientation, relative to the direction of the tidal flow, under the influence of the flow of water moving past the system.

Preferably, the method comprises allowing the tidal flow to flow past aligning means on the system such as to effect displacement of the system in order to stabilise and/or orient the system with respect to the tidal flow.

15 Preferably, the system comprises a base and a hydroelectric turbine mountable on the base, the method comprising the step of securing the turbine to the base prior to lowering the system towards the seabed.

Preferably, the method comprises utilising the tidal flow to orient the system such that the turbine is operatively aligned with the direction of the tidal flow.

20 According to another aspect of the present invention there is provided a method of deploying a hydroelectric turbine system in a running tide, the method comprising the steps of: positioning a deployment vessel and the hydroelectric turbine system above a deployment site; lowering the hydroelectric turbine system from the deployment vessel towards the deployment site; and
25 utilizing tidal flow of water past the hydroelectric turbine system to at least one of achieve and maintain a desired orientation of the hydroelectric turbine system with respect to the tidal flow of water by allowing the tidal flow of water to flow past aligning means on the hydroelectric turbine system such as to effect displacement of the hydroelectric turbine system in order to at least one of orient and stabilize the hydroelectric turbine system with respect to the tidal flow of water.

Brief description of the drawings

30 Figure 1 illustrates a perspective view of a first embodiment of a hydroelectric turbine system according to the present invention;

Figure 2 illustrates an alternative arrangement of a portion of the hydroelectric turbine system shown in Figure 1;

Figure 3 illustrates a perspective view of a second embodiment of a hydroelectric turbine system according to the present invention; and

- 5 Figure 4 illustrates a perspective view of a portion of a hydroelectric turbine system according to a third embodiment of the invention.

Detailed description of the drawings

10

Referring now to Figure 1 of the accompanying drawings, there is illustrated a first embodiment of a hydroelectric turbine system according to the present invention, generally indicated as 10, which is designed to be located on the seabed in an area of high tidal flow, in order to effect the hydroelectric generation of electricity. The system 10 comprises a base
15 12 which is adapted to carry a hydroelectric turbine T thereon, which turbine T may then form part of the system 10. In the embodiment illustrated the base 12 is triangular in plan, although it will be appreciated from the following description of the operation of the system 10 that the shape of the base 12 is not limited to being triangular, and may be of any other suitable form. It will also be appreciated that the hydroelectric turbine T to be mounted on
20 the base 12 may be of any suitable form.

The base 12 comprises a pair of lateral beams 14 extending between which is a rear beam 16, each apex of the base 12 being defined by a foot 18, between which the beams 14, 16 extend. The feet 18 may be suitably designed to be fixed to the seabed in any number of
25 arrangements. The base 12 may be made of any suitable material or combination of materials, and in the embodiment illustrated is formed primarily of tubular steel. The base 12 may be modular in nature in order to allow repair and/or replacement of individual components thereof.

30 The system 10 further comprises a mount 20 secured to the base 12, and which is adapted to receive and retain the hydroelectric turbine T therein. The mount includes a pair of uprights 22, each of which extends from a respective one of the lateral beams 14, and a split collar 24 supported on the uprights 22. The collar 24 is substantially cylindrical in shape, and in use receives the hydroelectric turbine therein, which may be secured to the collar 24 via a stator

(not shown) of the turbine. Again it will be appreciated that the design of the mount 20 is merely one example of a mechanism for securing a turbine to the base 12, and the mount 20 may be of any other suitable form. In the embodiment illustrated the system 10 is designed such that when mounted on the seabed, a longitudinal axis L of the base 12 should be
5 substantially aligned with the direction of tidal flow at the deployment site. The mount 20 is therefore oriented in order to face the hydroelectric turbine directly into the direction of tidal flow, with the base 12 located on the seabed.

The system 10 is intended to be lowered to the seabed from a barge or similar deployment
10 vessel (not shown), for example using a number of lowering lines connected to the base 12 and lowered via winches from the deployment vessel. As mentioned above, the areas in which the system 10 will be deployed will be areas of high tidal flow, which embody difficult working conditions both on and below the surface of the sea. Lowering an object
15 generally result in undesired movement such as spinning/oscillation of the object. This can result in tangling of the lines being used to lower the object, and, in the case of a hydroelectric turbine, which must be accurately aligned with the tidal flow, can make it extremely difficult to correctly orient the turbine with respect to the direction of tidal flow, when positioning the turbine onto the seabed.

20

The system 10 of the present invention overcomes the above-mentioned problems by providing aligning means in the form of a pair of fins 26 mounted to the base 12, and in particular extending rearwardly from the feet 18 mounted on either of the rear beam 16. In the embodiment illustrated the fins 26 are substantially aligned with the longitudinal axis L
25 of the base 12. Once lowered into the tidal flow, the fins 26 act as rudders providing stability to the base 12 and also effecting alignment of the base 12 with respect to the tidal flow, forcing rotation of the base 12 until the longitudinal axis L is substantially parallel with the direction of tidal flow. It will of course be understood that the orientation of the fins 26 may be varied in order to achieve a desired orientation of the base 12 with respect to
30 the direction of tidal flow.

In the embodiment illustrated the system 10 is intended to be lowered to the seabed from the deployment vessel with the rear beam 16 defining a trailing edge of the system 10. This means that the forward tip of the triangular plan of the base 12 points into the tidal flow,

with the pair of fins 26 trailing from the rear. In this position the pair of fins 26 are at their most effective, both in terms of stabilising and orienting the system 10 in the tidal flow. The fins 26 could of course be positioned at any other location, or supplemented with additional fins (not shown) located around the base 12.

5

The system 10 of the present invention therefore utilises the kinetic energy of the tidal flow in order to both stabilise and correctly orient the system 10 as it is lowered from a deployment vessel towards the seabed. The aligning means, in the form of the pair of fins 26, may therefore be passive as they utilise this kinetic energy of the tidal flow as a source
10 of power to provide the above mentioned functionality. It will be appreciated that active aligning means (not shown) could be utilised, for example in the form of one or more propellers, water jets, etc., in order to effect the stabilisation and orientation of the system 10 when being lowered in a tidal flow. However, this would add to both the cost and complexity of the system 10, and given the harsh underwater conditions in which the system
15 10 will reside for extended periods, the reliability of such active aligning means could be an issue. The passive fins 26 are a simple yet highly effective aligning means for the system 10.

Turning now to Figure 2, the rear corner of the base 12 is shown, in which the fin 26 is
20 shown mounted in a slightly different position, whereby a gap is left between the upper edge of the fin 26 and the top of the foot 18. This is to prevent the fin 26 from piercing or otherwise damaging the barge or similar deployment vessel (not shown), used to deploy the system 10. The system 10 is intended to be towed to a particular deployment site suspended beneath the deployment vessel, and to be then lowered away from the underside of the
25 deployment vessel towards the seabed. Thus, in particular given the relatively harsh conditions present at these deployment sites, it is possible that the system 10 may be lowered unevenly from beneath the barge, which could result in one or more of the fins 26 contacting the underside of the barge. By lowering the fins 26 slightly beneath the upper edge of the feet 18, such an occurrence is rendered extremely unlikely.

30

Referring now to Figure 3, there is illustrated a second embodiment of a hydroelectric turbine system according to the present invention, generally indicated as 110. In this second embodiment like components have been accorded like reference numerals, and unless otherwise stated perform a like function. The system 110 comprises a base 112 which is

formed from a pair of lateral beams 114 connected between which is a rear beam 116. Each apex of the base 112 is defined by a foot 118. Although not illustrated, in use the system 110 would be provided with a mount for securing a hydroelectric turbine T to the base 112 to form part of the system 110.

5

The system 110 further comprises aligning means in the form of a pair of fins 126 which are mounted on the rear beam 116, and which project upwardly and rearwardly from the rear beam 116. In use the tidal flow of water past the fins 126 will be cleaner or less turbulent than the flow past the fins 26 as positioned on the system 10 of the first embodiment. As a result the fins 126 of the second embodiment will be more effective in stabilising and orienting the system 110 with respect to the direction of tidal flow.

Referring to Figure 4, there is illustrated a third embodiment of a hydroelectric turbine system, generally indicated as 210. In this third embodiment like components have again been accorded like reference numerals, and unless otherwise stated perform a like function. Figure 4 shows only a portion of the alternative embodiment, and in particular shows a mount 220 to which a hydroelectric turbine T is secured, similar to the arrangement of the first embodiment described above.

The mount 220 comprises a pair of uprights 222 and collar 224 into which the turbine T is seated. The system 210 further comprises aligning means in the form of a pair of fins 226 which project from the pair of uprights 222. Again the tidal flow of water past this position of the system 210 may be less turbulent than the flow past and around the base 212 of the system 210.

25

It will of course be appreciated that the invention may be implemented by utilising a combination of the above mentioned positions for the aligning means. The aligning means may be located at any other suitable location, and may be of any other suitable form, once capable of stabilising and/or orienting the system when suspended, or being lowered/raised, in a tidal flow.

30

It will thus be appreciated that the system 10, 110, 210 of the present invention, and the method of deploying a hydroelectric turbine system according to the invention, greatly simplifies the deployment of a hydroelectric turbine onto the seabed. This is achieved by

stabilising the system as it is lowered towards the seabed and conversely when the system is being raised from the seabed, for example, for repair or replacement. The system and method of the invention avoid tangling of lowering lines, and ensure that the system is correctly oriented when it reaches the seabed, thereby avoiding the need for further
5 positioning at that stage. In addition, as the system and method of the invention are designed to allow deployment during a running tide, as opposed to during slack water, the time allowed for a deployment or recovery of the system is greatly increased.

What is claimed is:

1. A method of deploying a hydroelectric turbine system in a running tide, the method comprising the steps of:
 - positioning a deployment vessel and the hydroelectric turbine system above a deployment site;
 - lowering the hydroelectric turbine system from the deployment vessel towards the deployment site; and
 - utilizing tidal flow of water past the hydroelectric turbine system to at least one of achieve and maintain a desired orientation of the hydroelectric turbine system with respect to the tidal flow of water by allowing the tidal flow of water to flow past aligning means on the hydroelectric turbine system such as to effect displacement of the hydroelectric turbine system in order to at least one of orient and stabilize the hydroelectric turbine system with respect to the tidal flow of water.
2. A method according to claim 1 comprising utilizing the tidal flow of water past the hydroelectric turbine system to at least one of effect and maintain stability of the hydroelectric turbine system in the tidal flow of water.
3. A method according to claim 1 or 2 wherein the step of lowering the hydroelectric turbine system further comprises utilizing lowering means which permit the hydroelectric turbine system to be displaced into the desired orientation, relative to the direction of the tidal flow of water, under the influence of the tidal flow of water moving past the hydroelectric turbine system.
4. A method according to any one of claims 1 to 3 in which the hydroelectric turbine system comprises a base and a hydroelectric turbine mountable on the base, the method comprising the step of securing the turbine to the base prior to lowering the hydroelectric turbine system towards the deployment site.
5. A method according to claim 4 comprising utilizing the tidal flow of water to orient the hydroelectric turbine system such that the turbine is operatively aligned with the direction of the tidal flow of water.

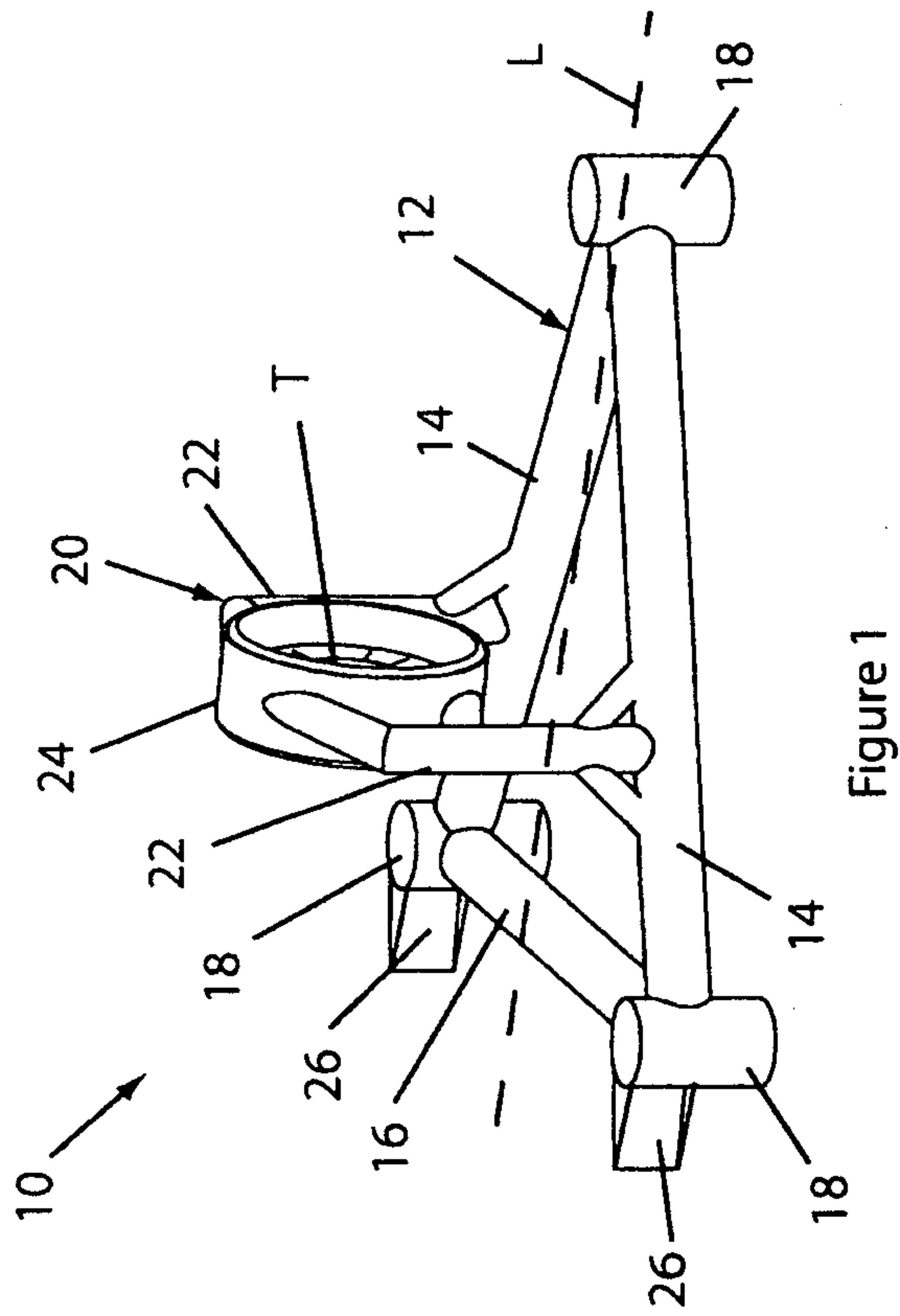

Figure 1

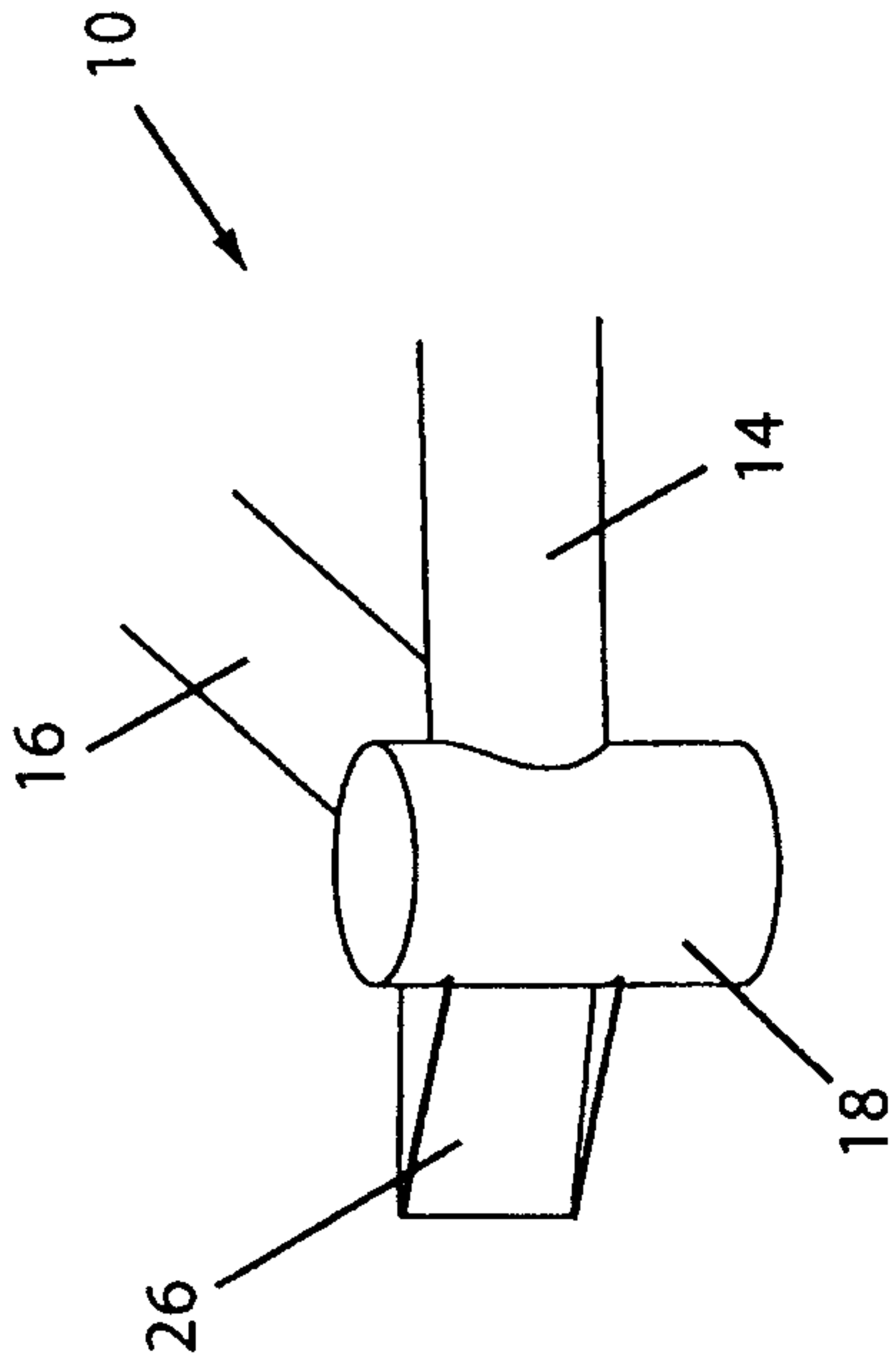

Figure 2

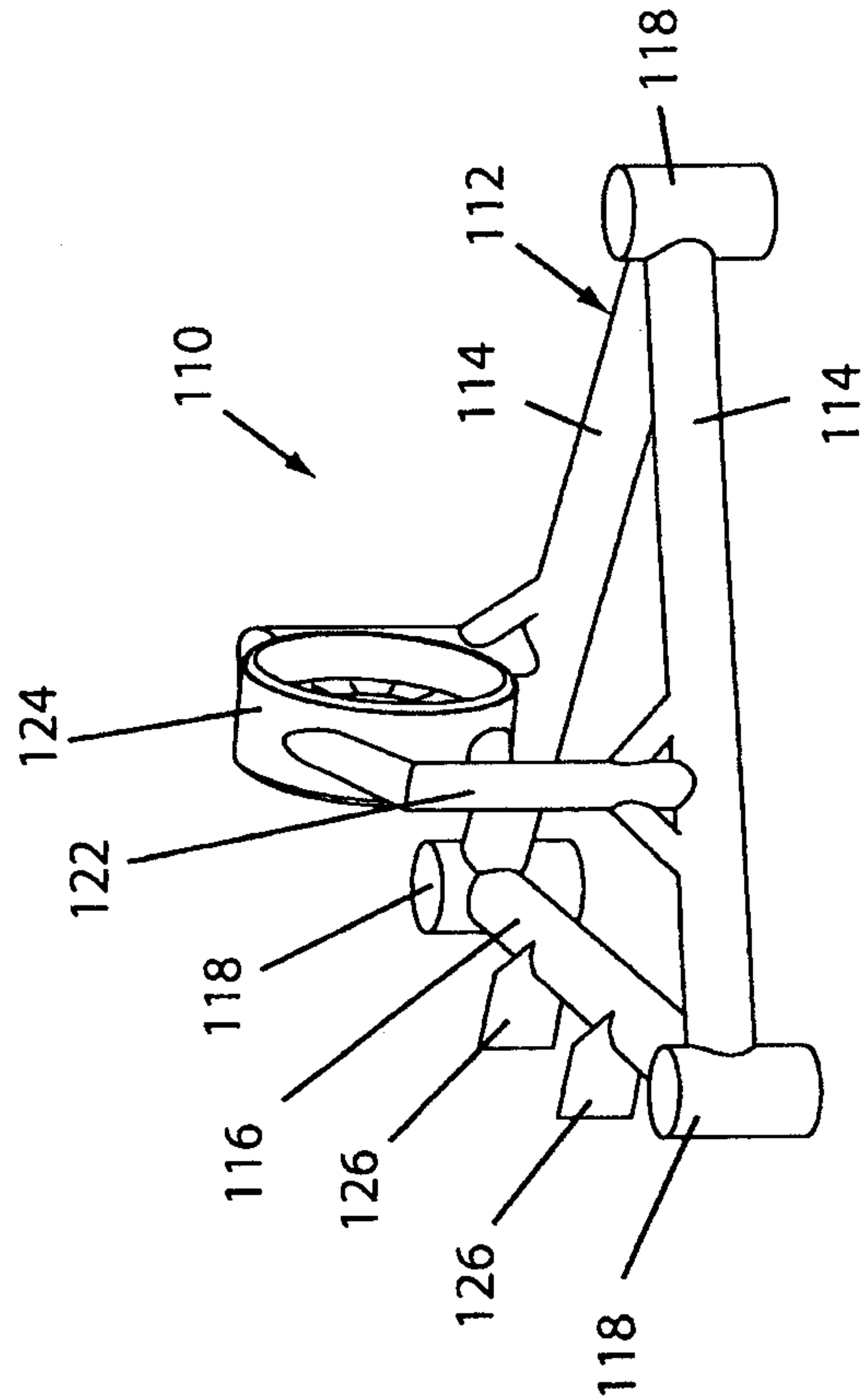

Figure 3

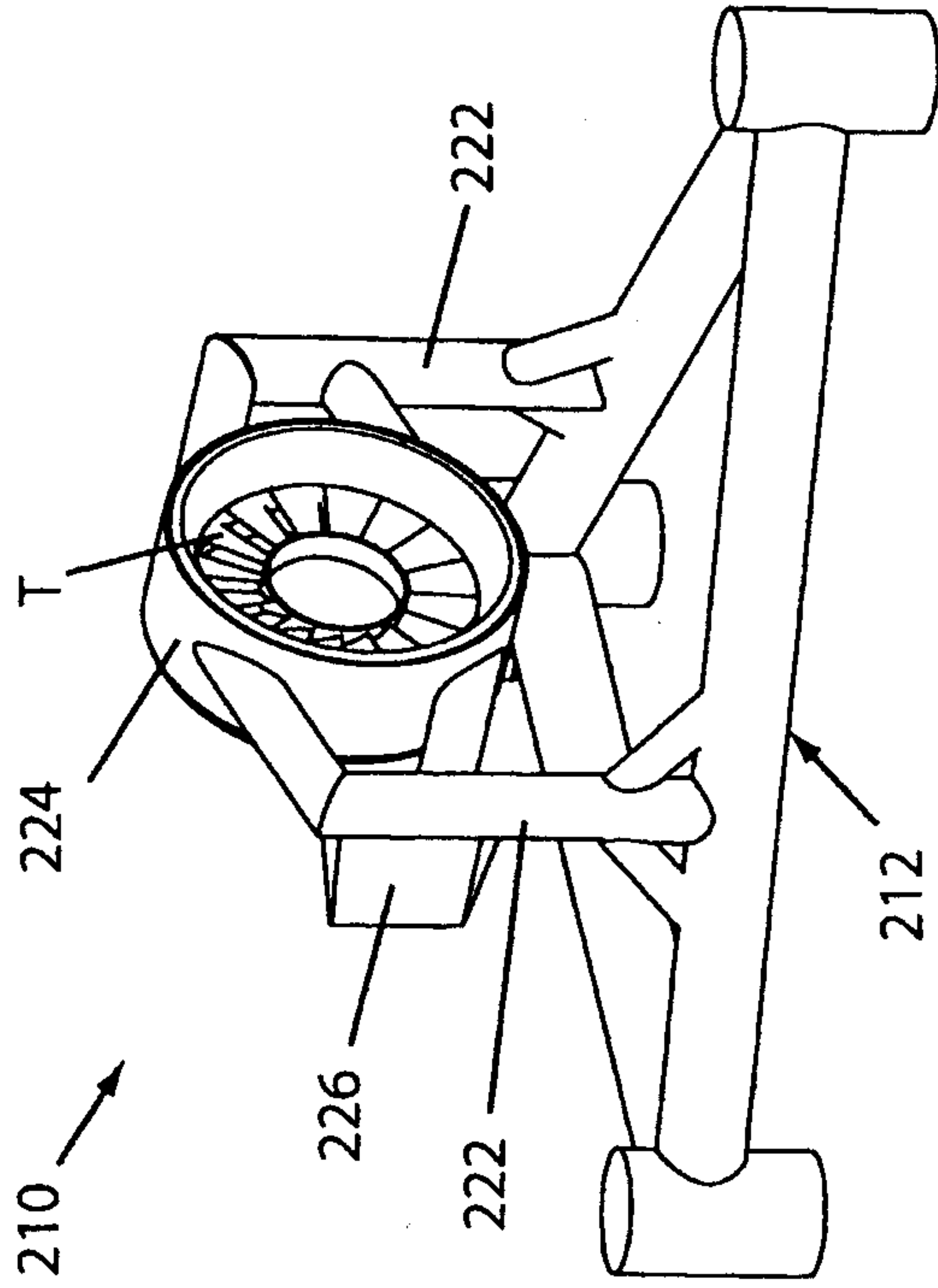

Figure 4

