



INTERNATIONAL APPLICATION PUBLISHED UNDER THE PATENT COOPERATION TREATY (PCT)

<p>(51) International Patent Classification ⁶ : A61B 17/34, 17/28</p>	<p>A1</p>	<p>(11) International Publication Number: WO 97/42889 (43) International Publication Date: 20 November 1997 (20.11.97)</p>
<p>(21) International Application Number: PCT/GR96/00012 (22) International Filing Date: 10 May 1996 (10.05.96) (71)(72) Applicant and Inventor: GIANNADAKIS, Emmanuil [GR/GR]; 4-6 Makrinitis Street, GR-115 22 Athens (GR). (74) Agent: MARIS, George; 6 Navarinou Street, GR-106 80 Athens (GR).</p>		<p>(81) Designated States: JP, US, European patent (AT, BE, CH, DE, DK, ES, FI, FR, GB, GR, IE, IT, LU, MC, NL, PT, SE). Published <i>With international search report.</i></p>

(54) Title: SYSTEM OF LAPAROSCOPIC-ENDOSCOPIC SURGERY

(57) Abstract

The invention pertains to a laparoscopic surgical system designed to make possible the entry of various laparoscopic instruments into the human body. The present system provides the possibility of simultaneous use of more than one instrument from one and only one hole of the wall over the intervent area under surgery, and also of modified currently available laparoscopic-endoscopic instruments as well as the introduction of other surgical instruments.

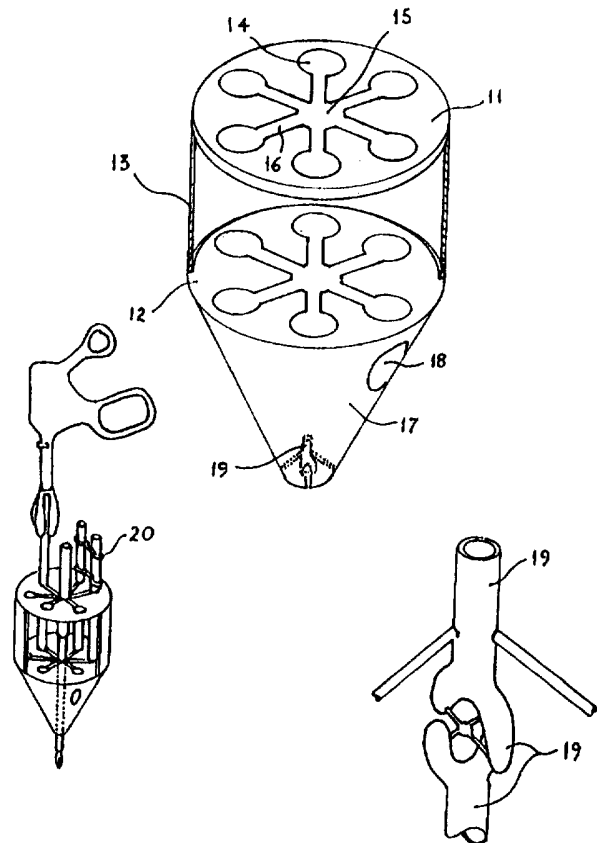

FOR THE PURPOSES OF INFORMATION ONLY

Codes used to identify States party to the PCT on the front pages of pamphlets publishing international applications under the PCT.

AL	Albania	ES	Spain	LS	Lesotho	SI	Slovenia
AM	Armenia	FI	Finland	LT	Lithuania	SK	Slovakia
AT	Austria	FR	France	LU	Luxembourg	SN	Senegal
AU	Australia	GA	Gabon	LV	Latvia	SZ	Swaziland
AZ	Azerbaijan	GB	United Kingdom	MC	Monaco	TD	Chad
BA	Bosnia and Herzegovina	GE	Georgia	MD	Republic of Moldova	TG	Togo
BB	Barbados	GH	Ghana	MG	Madagascar	TJ	Tajikistan
BE	Belgium	GN	Guinea	MK	The former Yugoslav Republic of Macedonia	TM	Turkmenistan
BF	Burkina Faso	GR	Greece	ML	Mali	TR	Turkey
BG	Bulgaria	HU	Hungary	MN	Mongolia	TT	Trinidad and Tobago
BJ	Benin	IE	Ireland	MR	Mauritania	UA	Ukraine
BR	Brazil	IL	Israel	MW	Malawi	UG	Uganda
BY	Belarus	IS	Iceland	MX	Mexico	US	United States of America
CA	Canada	IT	Italy	NE	Niger	UZ	Uzbekistan
CF	Central African Republic	JP	Japan	NL	Netherlands	VN	Viet Nam
CG	Congo	KE	Kenya	NO	Norway	YU	Yugoslavia
CH	Switzerland	KG	Kyrgyzstan	NZ	New Zealand	ZW	Zimbabwe
CI	Côte d'Ivoire	KP	Democratic People's Republic of Korea	PL	Poland		
CM	Cameroon	KR	Republic of Korea	PT	Portugal		
CN	China	KZ	Kazakstan	RO	Romania		
CU	Cuba	LC	Saint Lucia	RU	Russian Federation		
CZ	Czech Republic	LI	Liechtenstein	SD	Sudan		
DE	Germany	LK	Sri Lanka	SE	Sweden		
DK	Denmark	LR	Liberia	SG	Singapore		
EE	Estonia						

SYSTEM OF LAPAROSCOPIC - ENDOSCOPIC SURGERY

The invention pertains to a laparoscopic surgical system designed to make possible the entry of various laparoscopic instruments into the human
5 body. The present system provides the possibility of simultaneous use of more than one instruments from one and only one hole of the wall over the (intervent) area under surgery, and also of modified currently available laparoscopic - endoscopic instruments as well as the introduction of other surgical instruments.

10 The entry of laparoscopic instruments into the human body has until now been obtained by means of the insertion through a single aperture of a special type piercing laparoscopic cylinder or port ("TROCAR") which may be equipped with reducers. The currently existing laparoscopic TROCARS with a single hole have certain disadvantages in spite of their wide use. For example, they afford
15 a limited space for easy manipulation, necessitate larger and numerous incisions and consequently a larger numbers of scars as well as more time, preclude the use of curved instruments as well as increase the possibility of leakage of inflatory gas and therefore overburden the entire surgical operation. Further more the existing laparoscopic instruments hinder the easy and
20 effective grasping of viscera.

The present invention is designed to introduce a laparoscopic surgical system capable of making a larger number of manipulations and of facilitating the use of various instruments, the ultimate result being the reduction of operation time, anesthesia time (thus reducing cost) an improved post
25 operational condition for the patient (less morbidity and hospital time) and better aesthetic result.

The present system can achieve the introduction of numerous laparoscopic instruments by means of a mechanically extendible laparoscopic cylinder through a single hole through the abdominal wall rather than through
30 numerous holes as was the practice until now. The entire process involved by this method is mechanically achieved by means of a diaphragm having numerous patterns and sizes thus affording a high degree of interchangeability.

The main advantages of the proposed system are the following:

1. More space through a single hole and capability of using a multiport system with or without a diaphragm as well as the use of a simple reducer.
2. External and internal minimization of traumatic area (less scars, better aesthetic result).
- 5 3. Compatibility and more effective combination of proposed system with open surgery instruments.
4. Accommodation of instruments of various sizes.
5. Easy handling of multiport system and diaphragm by the TROCAR.
6. Performance of laparoscopic operations which have been impossible or
10 extremely difficult up to now.
7. Optimization of the most functional internal space of TROCAR.
8. Simultaneous introduction of more than one instruments.
9. Single hand manipulation by the surgeon working through a single orifice on the human body.
- 15 10. Considerable saving of time and minimum number of manipulations.
11. Possibility of introducing a proposed bent camera and proposed bent instruments of this system or future curved instruments.
12. Reduction of anesthesia time.
13. During the surgical or laparoscopic operation it is possible by means of the
20 laparoscopic sucker to grasp the slippery viscera, which cannot be easily held by ordinary surgical instruments, and it permits movements of them (viscera) with less lesions because of broad adhering surface that minimizes local pressures.
14. More effective and multi-operational combination of open surgery with the
25 proposed system.
15. Higher operational efficiency by combining either endoscopic, diagnostic or therapeutic procedures (ultrasonic heads, endoscopic camera or various endoscopic catheters and instruments with proposed system). This is achieved by employing:
30 a. the multiport system and
b. by means of a sucker which allows the insertion of other smaller laparoscopic instruments through its hole for the operation on concave viscera.
16. The control of quick stop of intraperitoneal hemorrhage from all peritoneal

concave and solid organs.

17. The closure of iatrogenic or traumatic apertures as well as the stopping of leakage of fluid from internal concave organs achieved by the sucker (less morbidity-infections, less complications and less re-operations).

5 A description of the invention is made here below with the aid of an example and with reference to the attached drawings as follows:

Figure 1 illustrates a side view of the extendible piercing laparoscopic cylinder 1 (TROCAR) combined with a multiport system of laparoscopic instruments. This cylinder can be introduced into an orifice of the abdominal area. Through this TROCAR the surgeon can introduce more than one
10 laparoscopic instruments with the additional advantage of doing it simultaneously. This can be achieved through the longitudinal separation of the TROCAR with the aid of one or more diaphragms 3. This particular TROCAR is divided into two or more parts and this arrangement enables it to adapt its size
15 to the operational requirements. A reducer (divertor) of appropriate diameter is introduced lengthwise into the TROCAR and is designed to ensure the airtightness and antibacterial protection of the abdominal area. A thin expandable film is placed on the top part of the TROCAR to seal the system's airtightness, after having removed the piercing shaft.

20 This TROCAR system, if combined with the well-known self-extended abdominal orifice, may achieve the minimization of traumatic area through the optimum use of a single hole. This arrangement results in permitting the surgeon to perform easy manipulations within the minimum time and to reduce all traumatic adverse effects.

25 One or more diaphragms 3 can be introduced and fitted into the reducer 2 lengthwise, as illustrated in Figure 2. Also the reducer cylinder (divertor) may by construction have appropriately fitted detachable diaphragms.

This inserted cylindrical reducer may be extended at will beyond the bottom part of the TROCAR within the abdominal area, namely at the contact
30 point of the organs to be operated on in such a way as to make possible the easy use of certain apparatus such as a special type camera, when it is necessary to intervene in special type of endoscopic operations.

Figure 3 indicates a top view of a multiport diaphragm, which has a

variable distance between the hole centers, a different pattern of holes and a variable depth in such a way as to have the possibility of interchangeability as regards its detachable diaphragms 3 . This arrangement or layout, which may be adjusted depending on the surgeon's requirements, can insure through the use of a given diameter reducer the introduction of laparoscopic instruments of varying sizes as well as the introduction of varying sizes instruments used in open surgery such as various types of staplers.

Figure 4A and Figure 4B show in detail the expansion and contraction mechanism of the proposed TROCAR. A shaft 4 running parallel to the longitudinal axis of the TROCAR located on one edge of the cylindrical surface bears a metal gear 5 around which a metal fiber 6 is wound. This fiber is connected to another gear which is fixed on the opposite edge of the longitudinally divided TROCAR. When the metal shaft turns clockwise, the TROCAR expands, while when it turns anti - clockwise, the TROCAR contracts in such a way as to accommodate variable size reducers at will.

Figure 5 illustrates a shallow 7 and a deep 8 diaphragm. The shallow diaphragm insures a high degree of mobility and cross handling of the instruments . The deep diaphragm acts as a viscera pushing device in the proximity of the organ being operated on, provided that the remaining holes are eliminated except for the operationally active.

Another possibility of the proposed invention, namely the fragmented base, is illustrated in Figure 6. This fragmented base is suitable for the introduction of large size instruments. It may be disassembled at will to accommodate such large size instruments and immediately afterwards can be assembled once again around their shafts, that are smaller in diameter than their apex or their handles, leaving their handles outside the organ area operated on within easy reach.

Figure 7 indicates a laparoscopic sucker 9, which is a part of the present invention and is designed to grasp and adhere on to the viscera not easily held by conventional instruments of present technology such as forceps etc. A hemispherical contact area is formed through an adjustable air - flow under pressure fed through the sucker's concave shaft. This surface having an appropriate curvature can grasp, lift, be fitted or adhered on to the viscera

being operated on.

In order that the sucker may have the desired rigidity and may pass through the hole of the extendible cylinder, while retaining a satisfactory degree of flexibility necessary for acquiring an optimum curvature and for
5 obtaining the maximum grasping of viscera, it is made of elastic material, such as transparent rubber necessary to watch the internal manipulations, or of thin metallic foil of a predetermined extendible form and size. The sucker's shape is obtained by feeding gas under pressure and can vary its functional size from a minimum to a maximum. The gas flow passes through a side hole on the
10 sucker's metal shaft while positive pressure is retained through the use of a one way valve located within the sucker gas feeding line. At the level of the handle of the sucker instrument, which makes an angle with the longitudinal axis of the sucker shaft, there is a port supplying negative pressure (suction). At the handle of the sucker there is another port, equipped with a one way valve,
15 which permits the entrance of miniature endoscopic instruments, catheters, cameras etc, for the interior surgery of internal organs. The aforementioned instruments pass through the entire length of the sucker shaft as well as the sucker cavity and into the adhered organ being operated on.

The multi - instrument resembles a revolver mill, see Figure 8. It
20 consists of a top **11** and a bottom **12** circular metal plate interconnected with another via a cylindrical metal surface **13**. Both circular plates have a number of circumferential holes **14** as well as a central hole **15** in such a way that each one of the top holes is perfectly aligned with its corresponding bottom hole. Thus, if the top surface is a seven-port plate (six circumferential and one
25 central) then the bottom surface is also a seven port plate with its holes exactly underneath the top surface. In this example, therefore, seven vertical ducts are formed capable of accommodating six (one has to remain empty for motion freedom) different laparoscopic or endoscopic instruments. Furthermore, each one of the circumferential ducts is connected with the central one through a
30 radial slot **16**. The width of each slot is such so as to permit the easy sliding of a laparoscopic or an endoscopic instrument from a given circumferential duct of the multi-instrument's to its central duct and vice versa.

With the exception of the central duct and one circumferential duct, all

other ones are blind holes, i.e., they are used to accommodate laparoscopic or endoscopic instruments as a storage chamber. The central duct runs along the entire multi-instrument and is used to accommodate the laparoscopic instrument performing the operation at that time. The bottom plate is connected
5 to a conical surface. Specifically it is an inverted frustrum of a cone **17**, the large base of which has the same diameter as the bottom plate and the small base of which has an inner diameter (ID) equal to that of the central port's diameter. The outer diameter (OD) of the small base is a little larger than the ID depending on the metal thickness which the metal multi-instrument is made
10 of. The aforementioned circumferential duct terminates at the conical surface and is a permanently open hole **18**, equipped with a one way valve to preclude gas leakage for the utilization of an extra forceps .

Typically, the dimensions in (mm) of such a multi-instrument are as follows:

15 CYLINDER HEIGHT = 90, CYL. DIAMETER = 50 OD, CONE HEIGHT = 60
DUCT DIAMETER = 8, SLOT LENGTH = 2, SLOT WIDTH = 7

Figure 8 is a detail of a universal joint **19** used to achieve at least two degrees of freedom for the laparoscopic instrument performing the operation.

Figure 9 and Figure 10 illustrate the implementation of a scissors-like **20** and a telescopic **21** systems respectively. Both achieve operations at variable depths with high degree of precision but the former one permits operations at variable angles as well.

Notice that the handles of the proposed modified instruments resemble those of the currently available ones, with the exception that they differ in that
25 they are equipped with a mechanism capable of extending or retracting their length telescopically.

Furthermore, the proposed instruments have similar functions with the others in trade, e.g., rotation, grasping, coagulation, cutting, flexion etc. With respect to the proposed telescopically extendable instruments, their handles
30 are equipped with a spool containing metal wire that can turn clockwise or anti-clockwise (telescopic extension or retraction of the instrument). Depending on the TROCAR length and at a given corresponding point of the instrument's length the wire is unraveled and achieves a maximum predetermined

instrument length telescopically, and also may, at the surgeon's will, stop at any intermediate length determined by a special pin (see FIGURE 10) attached on to the center of the handle spool. Also there is a microdiaphragm within the interior of the smallest diameter extreme cylinder. This microdiaphragm is used
5 to separate the two wires from each other, i.e., the one used for operating the motion of the graspers or scissors head and the other one for the extension / retraction of the instrument itself motion. Finally, the space for retraction of the telescopically extendable concentric cylinders lies between the handle and internal orifice of the TROCAR divertor. Instruments commonly known as the
10 laparoscopic hook and the laparoscopic ball need neither a microdiaphragm nor the corresponding wire for the incising or grasping motion

With respect to the laparoscopic instruments equipped with a scissors-like extendable mechanism, their handles are constructed similarly (spool, pin, wire) to those of the telescopically extendable instruments. Notice, that when
15 the instrument is at a neutral position, the shaft is completely straight whereas when the handle spool is turned clockwise a desired flexion is attained. This is achieved through the fact that the scissors arms are of unequal length which provide preferential flexion to one side up to a maximum curving. In addition, their hollow shafts, beyond a certain point of their length, are made of a flexible
20 material which can closely follow the precise angle of flexion determined by the scissors-like mechanism in conjunction with the handle's pin position. Notice that telescopic and the scissors-like systems may be combined in the same instrument, with the following modification: their main bodies must be activated by two separate wires while their handles must be equipped with two sets of the
25 spool-pin mechanism, each set of a different color for easy distinction, e.g., red spool for telescopic extension and green spool for scissors curving.

The present system is principally designed to perform laparoscopic and combined endoscopic surgical operations as well as laparoscopic operations involving the use of large size open surgery instruments.

30 The introduction of the proposed TROCAR system through a single orifice of the abdominal wall makes possible the passage and contact of the abdominal cavity (peritoneal cavity) with the external area through his TROCAR duct - cylinder, which is rigidly attached to the entire thickness of abdominal wall

after having pierced it. This hole is opened by means of a simple Veres needle or directly via the piercing stylus of the TROCAR system following a small (5mm - 10mm) incision on the abdominal wall.

The abdomen is inflated with CO₂ or other compatible with laparoscopic surgery gas either by means of a special type Veres needle adapter or by means of a special type air adapter of the TROCAR system. If the piercing stylus (shaft) is directly used, it must be preceded by a small boring of variable size at the surgeon's discretion and depending on the final TROCAR diameter opening, which is made on the abdominal tissue with the use of a small knife.

10 The abdominal holes (and the corresponding number of TROCARs used) vary according to the type of the surgical operation. It should be noted that a special type self expansible material may be used as an external expandable film on the base of the TROCAR prior to its insertion into the abdomen which is obtained through circular oscillating moves. Once the surgeon inserts the appropriate reducer within the TROCAR, the expandable film, acting as a gas seal, is pierced and pushed onto one side of the reducer's cavity. Therefore, the endoscopic instrument can freely operate via the proposed TROCAR system.

20 The piercing stylus is removed upon the insertion of the TROCAR into the abdomen thus leaving inside only the cylindrical duct, which is connected to an appropriate rubber hose designed to feed additional gas into the abdomen in case of depletion. The duct is also equipped with a one way valve which prevents the leakage of CO₂ gas through the system. This is immediately followed by the TROCAR expansion to the desired diameter by means of rotating screws. In this way the cylinder is extended according to the surgeon's requirements. As soon as the desired diameter is obtained, the protective expandable film is removed from the upper surface of the TROCAR system and the multiport diaphragm system is introduced through the cylinder and the valve. The multiport diaphragm is fixed by means of clips on the external part of the cylinder. It consists of two or more removable or permanently fixed parts interconnected by means of a clip-on arrangement.

30 If more space is needed, we may use a diaphragm of great depth which can push downwards the patient's adjacent organs.

The diaphragm is either preliminary clipped on or is directly placed into the cylinder. One or more diaphragms may be used depending on the diameter of the cylinder, the requirements of the surgical operation, the usage of surgical operation, the usage of surgical instruments through the diaphragm channels and the surgeon's dexterity. Mechanical fasteners **20** (Figure 8) such as metal clips used to connect endoscopic, laparoscopic or surgical instruments with one another allow the surgeon considerably greater ease of operation since more than one instruments are manipulated by a single hand simultaneously.

We can introduce various instruments through the holes which exist in the variable diaphragm system and which have different sizes and shapes (round or oval) or which are formed by connecting together the parts of a disassembled base clipped on the main shaft. These instruments may be of the existing laparoscopic type, or they may also be of a larger size of general surgery as well as the proposed bent instruments of telescopic type which afford an increased manipulatory ease due to a greater bending angle.

In case the multi - instrument or a general surgery large size instrument is used, no diaphragm will be used in the system. The proposed instruments of the telescopic system and the scissors system have a shape and function similar to that of the existing instruments (scissors opening or shaft rotation) but they differ in respect of the angle of bending and of the depth variability according to the surgeon's requirements. They are interconnected by means of external clips which make possible their simultaneous motion in unison.

The multi - instrument facilitates the surgeon's work, who takes advantage of the elasticity of the abdominal wall because he can use through a single opening **11** various adjacent instruments depending on his needs, which he may shift on to the central hole at a time.

The sucker contains its own suction system of negative pressure and a one way valve. Negative pressure is achieved by connecting the sucker's central shaft with a vacuum pump in series with a sensitive manometer and / or flow meter. This less than atmospheric pressure is retained under the cavity of the sucker by the use of a one way valve of a "butterfly" type of vane. It is possible to introduce through the sucker's hollow shaft **12** other instruments

such as "Fogarty", small "Folley", "Nelaton pipes" or other suckers of a smaller size, choledochoscope, small size endoscopes, "Basket" for lithotripsy or stone reducers, "Pig Tail" catheters, future circular anastomotic instruments, small atheroma incisors, as well as new instruments and angioinvasive
5 endoscopic instruments and staplers to be invented in the future or which are currently available and which will be used in other surgical operations.

The sucker may be used independently or in combination with the multi-instrument. One of the principal uses of the sucker in the easy and injury-free handling of adjacent viscera in the patient's body as well as the support and
10 tilting or turning of the organ operated on. It may be also used for haemostatic purposes through the introduction of gauge, small pieces of cotton, other haemostatic material ("Surgi-Cell", "Spongostan"), as well as for diagnostic purposes through the injection of radio opaque substances, the use of ultrasonic heads and miniature cameras 13, designed for exploratory surgery of
15 hollow organs. Furthermore, taking advantage of the sucker bell's negative pressure, foreign particles, such as stones, are removed and biopsies are performed.

CLAIMS

1. System of laparoscopic-endoscopic surgery characterized by laparoscopic, endoscopic and surgical instruments of variable and simultaneously adjustable length, diameter and shape which are capable of penetrating the abdominal wall through a single hole, such system including a mechanically extendible piercing laparoscopic cylinder, equipped with a multiform multiport base system on the cylinder's external orifice and with adjustable, multiform and borne within a detachable base diaphragms introduced into the cylinder along with the remaining instruments.
2. System of laparoscopic-endoscopic surgery according to Claim 1, which is characterized by a unilaterally or bilaterally mechanically extendible laparoscopic cylinder of variable wide spectrum diameter.
3. System of laparoscopic-endoscopic surgery according to Claim 2 which is characterized by a multiform base system in respect of the shape and size of its holes, their distance from one another and their distance from the plane located on the cylinder's longitudinal axis of symmetry, such base system also being multiport and bearing at its base detachable diaphragms of variable form and size, while the system of laparoscopic surgery can accommodate laparoscopic and endoscopic instruments of variable length, diameter and shape depending on the surgical requirement.
4. System of laparoscopic-endoscopic surgery according to Claim 3 which is characterized by a laparoscopic instrument which terminates at a sucker having a concave surface made of elastic or thin metallic foil, such surface having either a pre-determined fixed shape or acquiring a readily adjustable shape and size by feeding positive gas pressure into the sucker gas chamber according to existing requirements, a sucker designed to grasp, adhere on to and firmly hold the viscera being operated on.
5. System of laparoscopic-endoscopic surgery according to Claim 4 which is

characterized by a laparoscopic multi-instrument for optimum interchangeability equipped with several ducts running parallel to its longitudinal axis, where more than one laparoscopic instruments are placed up to a certain depth, while the selected laparoscopic instrument performing the operation passes through the
5 entire length of the multi-instrument.

6. System of laparoscopic-endoscopic surgery according to Claim 1 which is characterized in that the main instrument body or part of it consists of a system of extensible scissors-like mechanical arms the stems of which have unequal
10 length and are interlinked together and the flexion of such arms is determined by the tension of a wire which runs inside the instrument shaft and is regulated by a spool located on the handle and a pin that achieves the desired flexion for the manipulation of all type of laparoscopic, endoscopic and surgical instruments at variable operating depths and angles for additional flexibility of
15 the given surgical procedure.

7. System of laparoscopic-endoscopic surgery according to Claim 1 and Claim 6 which is characterized in that all laparoscopic, endoscopic and surgical instruments employed through this system are telescopically extendable in
20 respect of the free part of their main instrument body and thus able to act at variable operating surgery depths.

8. System of laparoscopic-endoscopic surgery according to Claim 1, Claim 6 and Claim 7, which is characterized in that telescopically extendable
25 instruments may be combined with instruments equipped with scissors-like mechanical systems.

9. System of laparoscopic-endoscopic surgery according to Claim 1 which is characterized in that all laparoscopic, endoscopic or surgical instruments
30 employed through this system can be connected with each other in pairs via mechanical fasteners so as to achieve a controlled single-hand surgical operation.

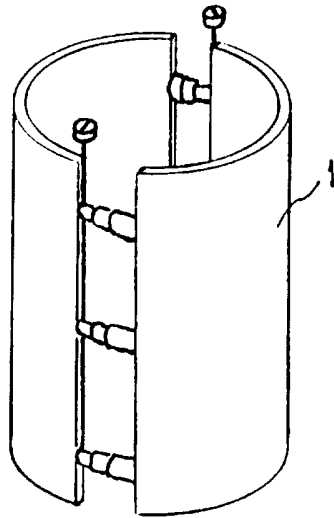

FIG. 1

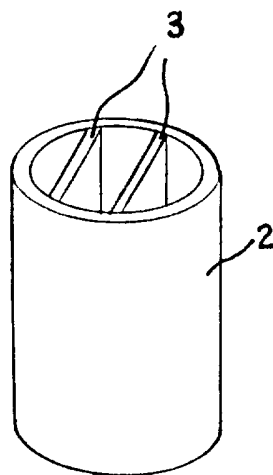

FIG. 2

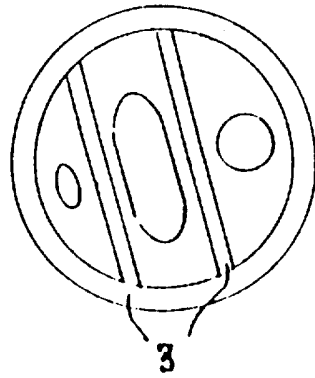

FIG. 3

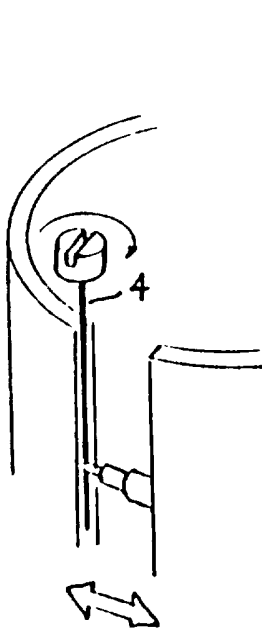

FIG. 4A

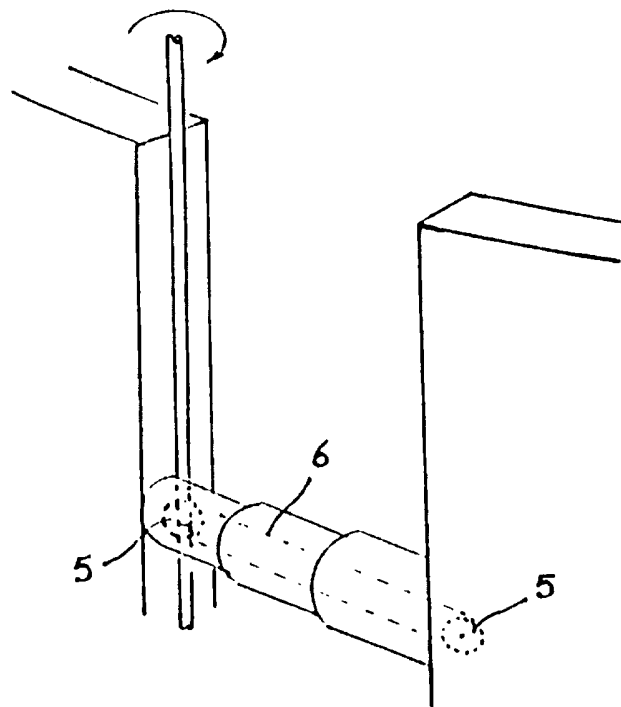

FIG. 4B

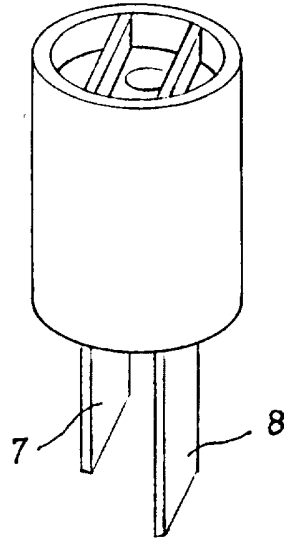

FIG. 5

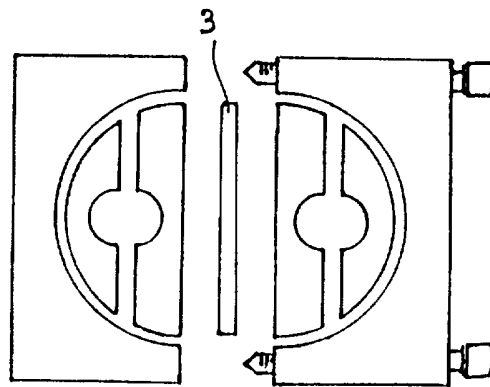

FIG. 6

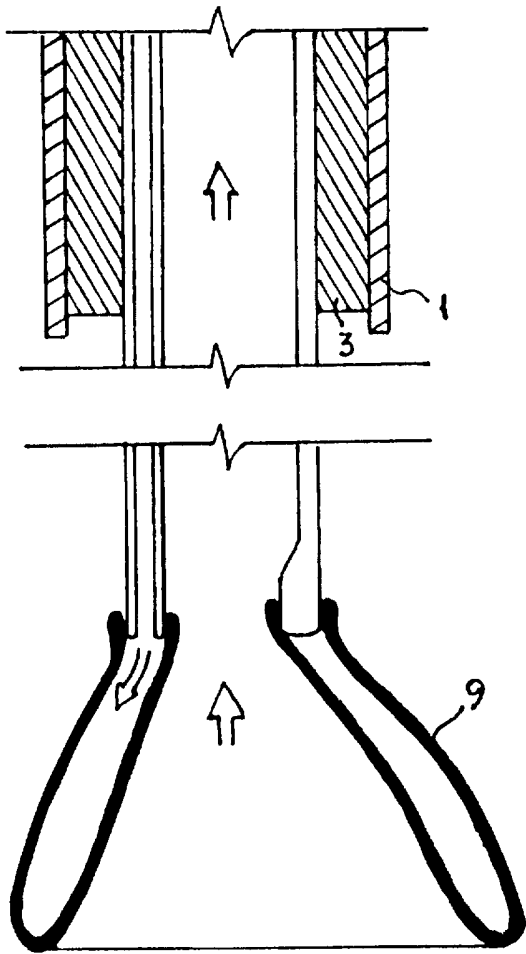

FIG. 7A

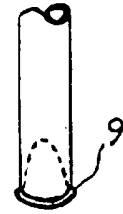

FIG. 7B

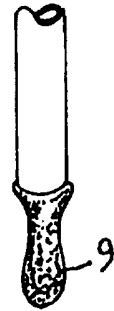

FIG. 7C

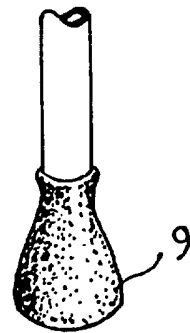

FIG. 7D

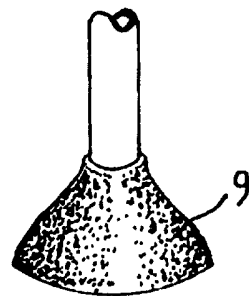

FIG. 7E

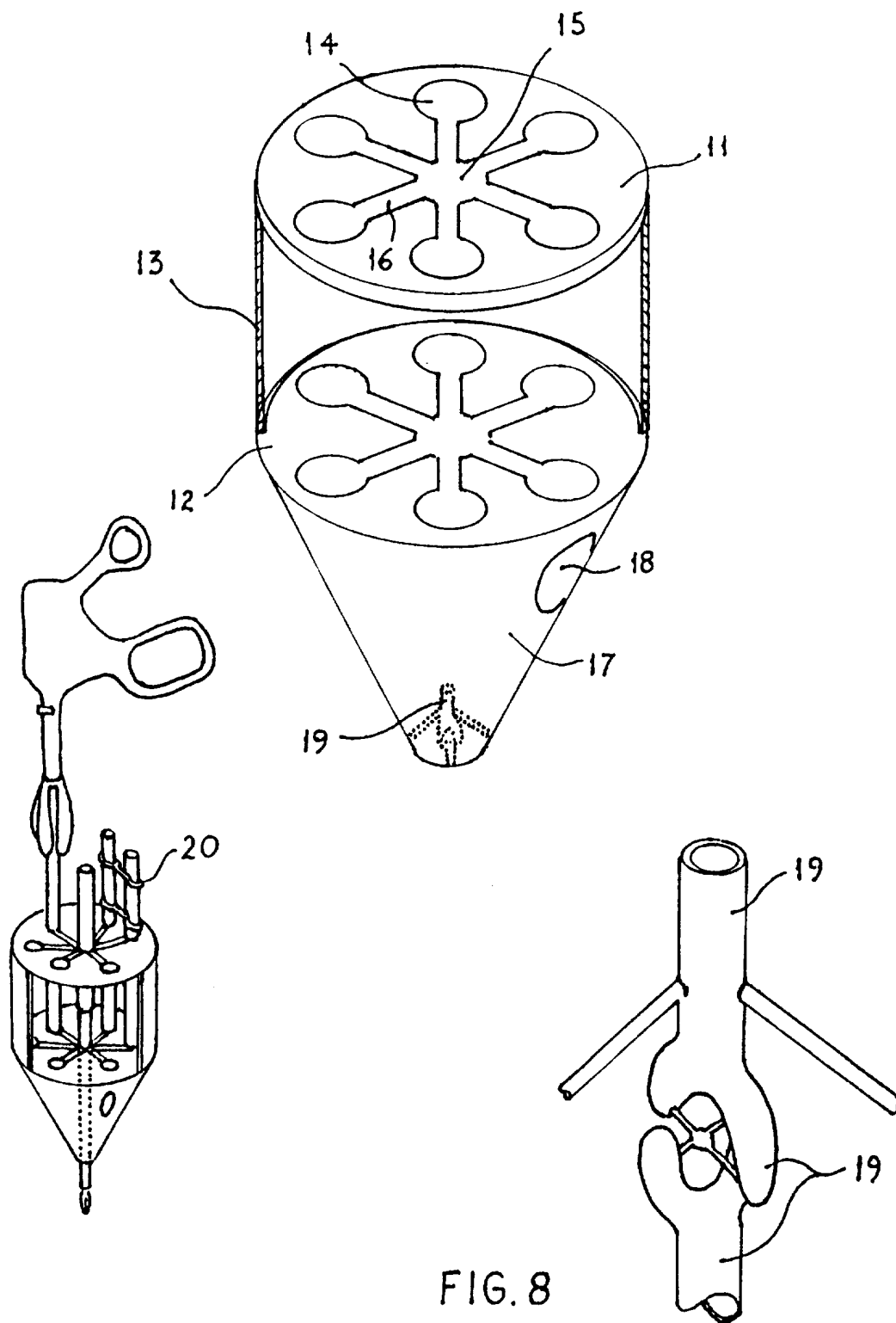
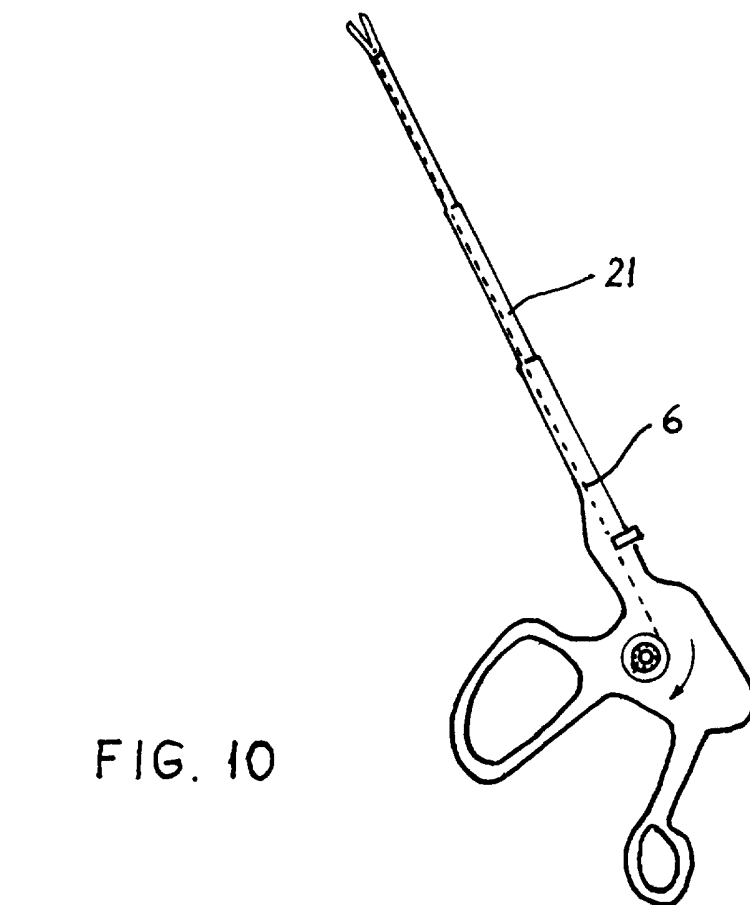
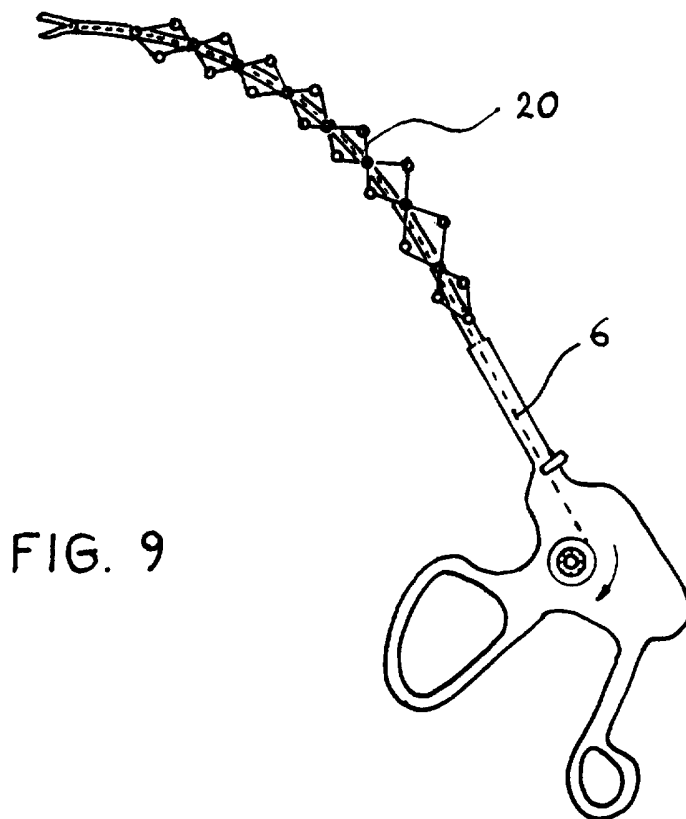

FIG. 8



INTERNATIONAL SEARCH REPORT

International Application No
PCT/GR 96/00012

A. CLASSIFICATION OF SUBJECT MATTER IPC 6 A61B17/34 A61B17/28		
According to International Patent Classification (IPC) or to both national classification and IPC		
B. FIELDS SEARCHED		
Minimum documentation searched (classification system followed by classification symbols) IPC 6 A61B		
Documentation searched other than minimum documentation to the extent that such documents are included in the fields searched		
Electronic data base consulted during the international search (name of data base and, where practical, search terms used)		
C. DOCUMENTS CONSIDERED TO BE RELEVANT		
Category *	Citation of document, with indication, where appropriate, of the relevant passages	Relevant to claim No.
A	WO,A,93 00946 (ENDOMEDIX CORP) 21 January 1993 see page 8, line 34 - page 10, line 14 ---	1
A	EP,A,0 646 358 (PACESETTER AB) 5 April 1995 see column 3, line 36 - column 4, line 5 ---	1
A	US,A,3 789 852 (KIM S ET AL) 5 February 1974 -----	1
<input type="checkbox"/> Further documents are listed in the continuation of box C. <input checked="" type="checkbox"/> Patent family members are listed in annex.		
* Special categories of cited documents :		
"A" document defining the general state of the art which is not considered to be of particular relevance	"T" later document published after the international filing date or priority date and not in conflict with the application but cited to understand the principle or theory underlying the invention	
"E" earlier document but published on or after the international filing date	"X" document of particular relevance; the claimed invention cannot be considered novel or cannot be considered to involve an inventive step when the document is taken alone	
"L" document which may throw doubts on priority claim(s) or which is cited to establish the publication date of another citation or other special reason (as specified)	"Y" document of particular relevance; the claimed invention cannot be considered to involve an inventive step when the document is combined with one or more other such documents, such combination being obvious to a person skilled in the art.	
"O" document referring to an oral disclosure, use, exhibition or other means	"&" document member of the same patent family	
"P" document published prior to the international filing date but later than the priority date claimed		
Date of the actual completion of the international search <div style="text-align: center; font-size: 1.2em;">11 December 1996</div>	Date of mailing of the international search report <div style="text-align: center; font-size: 1.2em;">23.12.96</div>	
Name and mailing address of the ISA European Patent Office, P.B. 5818 Patentlaan 2 NL - 2280 HV Rijswijk Tel. (+ 31-70) 340-2040, Tx. 31 651 epo nl, Fax (+ 31-70) 340-3016	Authorized officer <div style="text-align: center; font-size: 1.2em;">Gérard, B</div>	

INTERNATIONAL SEARCH REPORT

Information on patent family members

International Application No

PCT/GR 96/00012

Patent document cited in search report	Publication date	Patent family member(s)	Publication date
WO-A-9300946	21-01-93	US-A- 5209741	11-05-93
EP-A-0646358	05-04-95	JP-A- 7265321	17-10-95
US-A-3789852	05-02-74	NONE	