



US00D468530S

(12) **United States Design Patent** (10) **Patent No.:** **US D468,530 S**  
**Murdoch et al.** (45) **Date of Patent:** **\*\* Jan. 14, 2003**

(54) **POUCH FOR DIGITAL CAMERA AND ACCESSORIES**

(75) Inventors: **Douglas H. Murdoch**, Santa Rosa, CA (US); **Lily S. Fisher**, Santa Rosa, CA (US)

(73) Assignee: **Daymen Photo Marketing, Ltd.**, Markham (CA)

(\*\*) Term: **14 Years**

(21) Appl. No.: **29/155,528**

(22) Filed: **Feb. 8, 2002**

(51) **LOC (7) Cl.** ..... **03-01**

(52) **U.S. Cl.** ..... **D3/276**

(58) **Field of Search** ..... D3/208, 215, 219, D3/225, 226, 243, 263, 268, 273, 276, 283, 285, 287, 289, 290, 301; D7/607; 206/316.1, 316.2; 224/583, 612, 908

(56) **References Cited**

**U.S. PATENT DOCUMENTS**

1,325,372 A	*	12/1919	Penny	.....	224/612
2,691,401 A	*	10/1954	Kontoff	.....	206/316.1
D174,536 S	*	4/1955	Eckhardt et al.	.....	D3/268
D249,824 S	*	10/1978	Koszegi	.....	D3/268
D251,873 S	*	5/1979	Pretzinger	.....	D3/268
D252,959 S	*	9/1979	Lang	.....	D3/268
D281,750 S	*	12/1985	Akabane	.....	D3/267
D310,299 S	*	9/1990	Ito	.....	D3/219
D361,428 S	*	8/1995	Akabane et al.	.....	D3/267
D368,581 S	*	4/1996	Cincotta	.....	D3/218
D384,810 S	*	10/1997	Kopel	.....	D3/226
D411,352 S	*	6/1999	Golenz et al.	.....	D3/301
D454,428 S	*	3/2002	Hillman	.....	D3/219
D455,256 S	*	4/2002	Tyler	.....	D3/219
D455,547 S	*	4/2002	Hillman	.....	D3/219
D457,723 S	*	5/2002	Tyler	.....	D3/267

\* cited by examiner

Primary Examiner—Celia Murphy

(74) *Attorney, Agent, or Firm*—R. Dabney Eastham

(57) **CLAIM**

We claim the ornamental design for a pouch for digital camera and accessories, as shown and described.

**DESCRIPTION**

FIG. 1 is a perspective view of a pouch for a digital camera and accessories showing our new design;

FIG. 2 is a front elevational view of the pouch shown in FIG. 1.

FIG. 3 is a rear elevational view of the pouch shown in FIG. 1.

FIG. 4 is a left elevational view of the pouch shown in FIG. 1.

FIG. 5 is a right elevational view of the pouch shown in FIG. 1.

FIG. 6 is a plan view of the pouch shown in FIG. 1.

FIG. 7 is a bottom side view of the pouch shown in FIG. 1.

FIG. 8 is a front perspective view of an alternate embodiment of the pouch shown in FIG. 1.

FIG. 9 is a front elevational view of the pouch shown in FIG. 8.

FIG. 10 is a rear elevational view of the pouch shown in FIG. 8.

FIG. 11 is a left elevational view of the pouch shown in FIG. 8.

FIG. 12 is a right elevational view of the pouch shown in FIG. 8.

FIG. 13 is a plan view of the pouch shown in FIG. 8; and, FIG. 14 is a bottom side view of the pouch shown in FIG. 8.

The pouch depicted in the drawings is “soft,” meaning that it is largely made of fabric, and is useful for carrying equipment and the accessories related to such equipment. An example of such equipment is a digital camera.

The broken lines shown along the edges of the flap, the sides, and the rear of the views are understood to represent stitching.

**1 Claim, 8 Drawing Sheets**

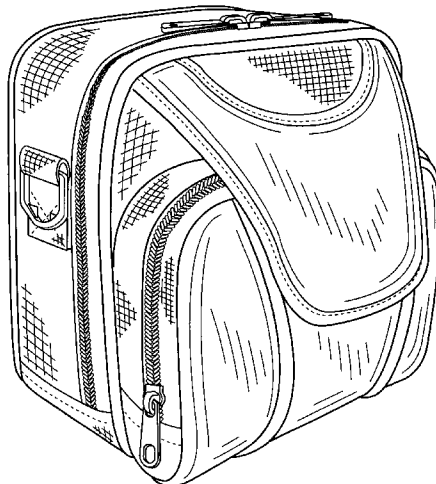

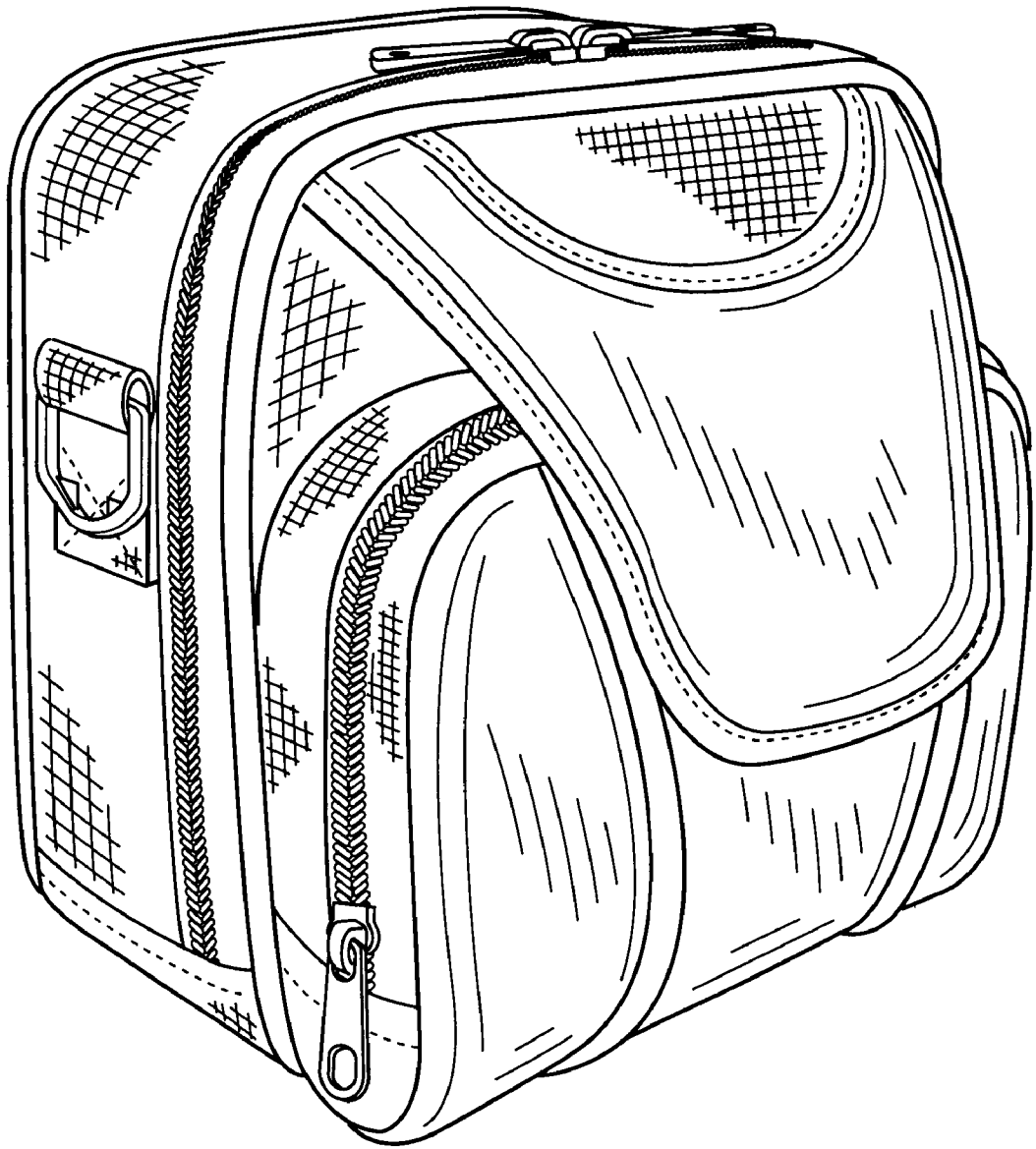

FIG. 1



FIG. 2

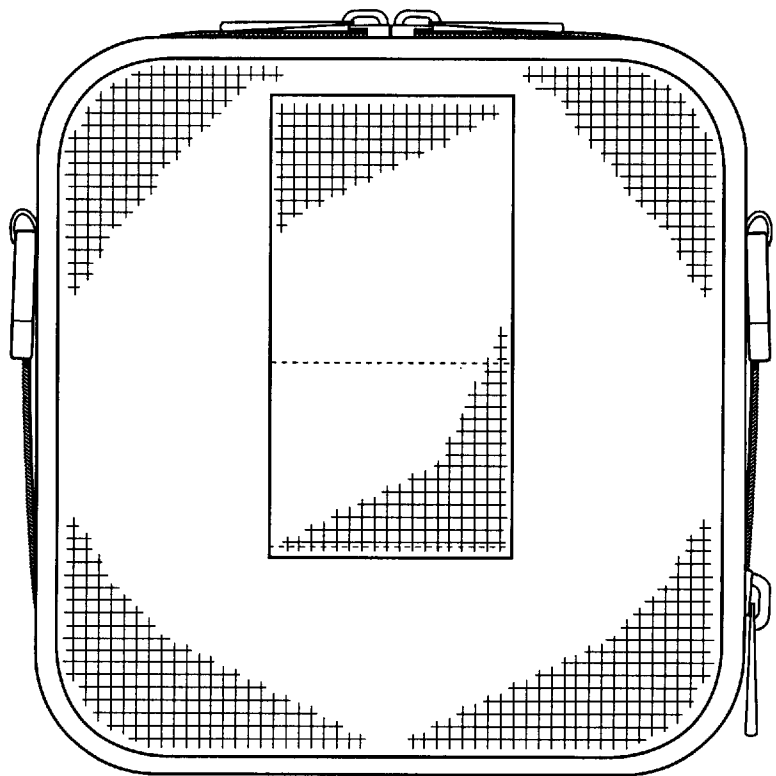

FIG. 3

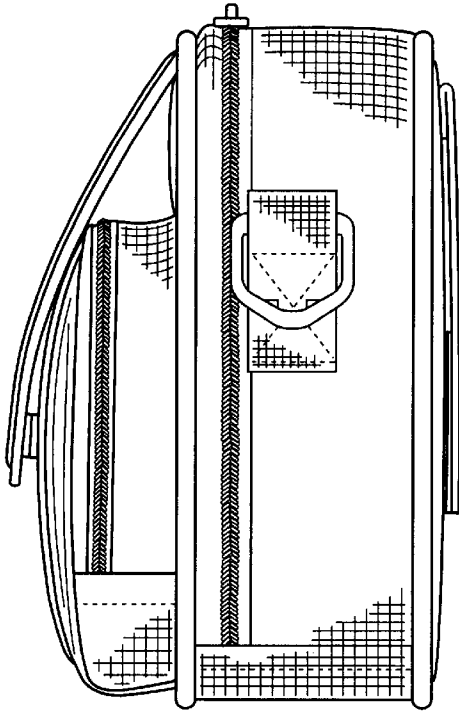
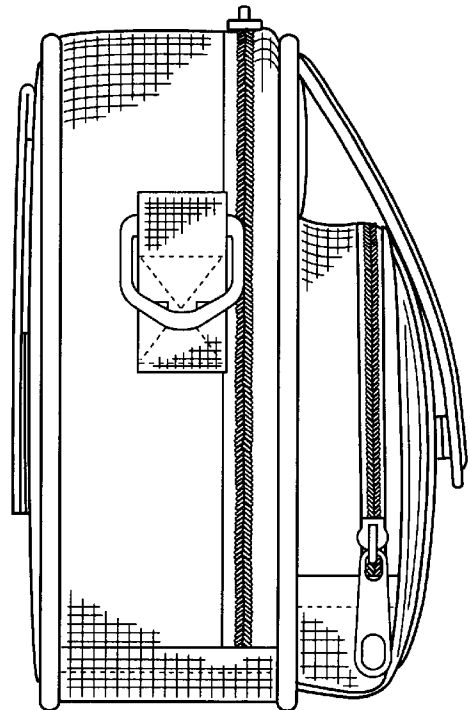

FIG. 4

FIG. 5



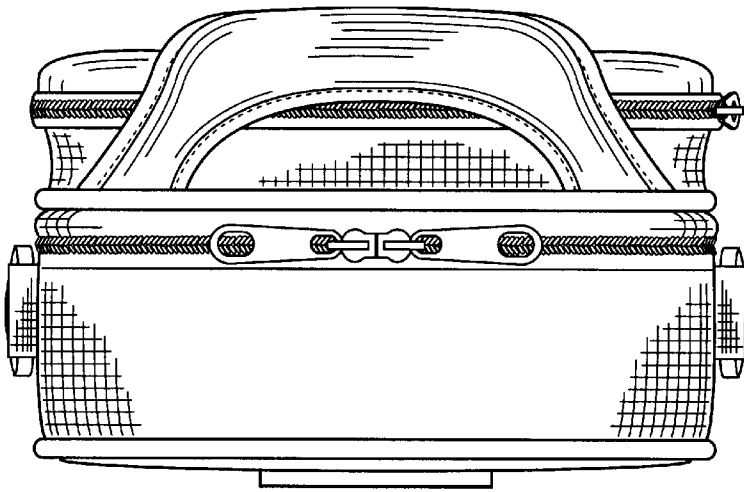

FIG. 6

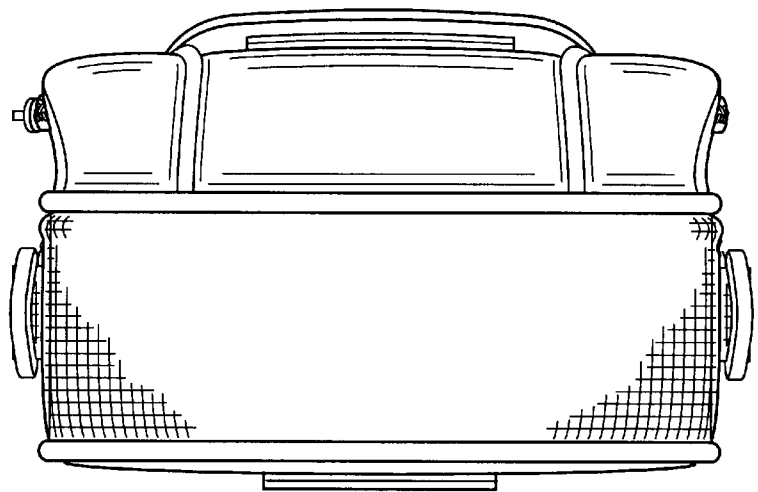

FIG. 7

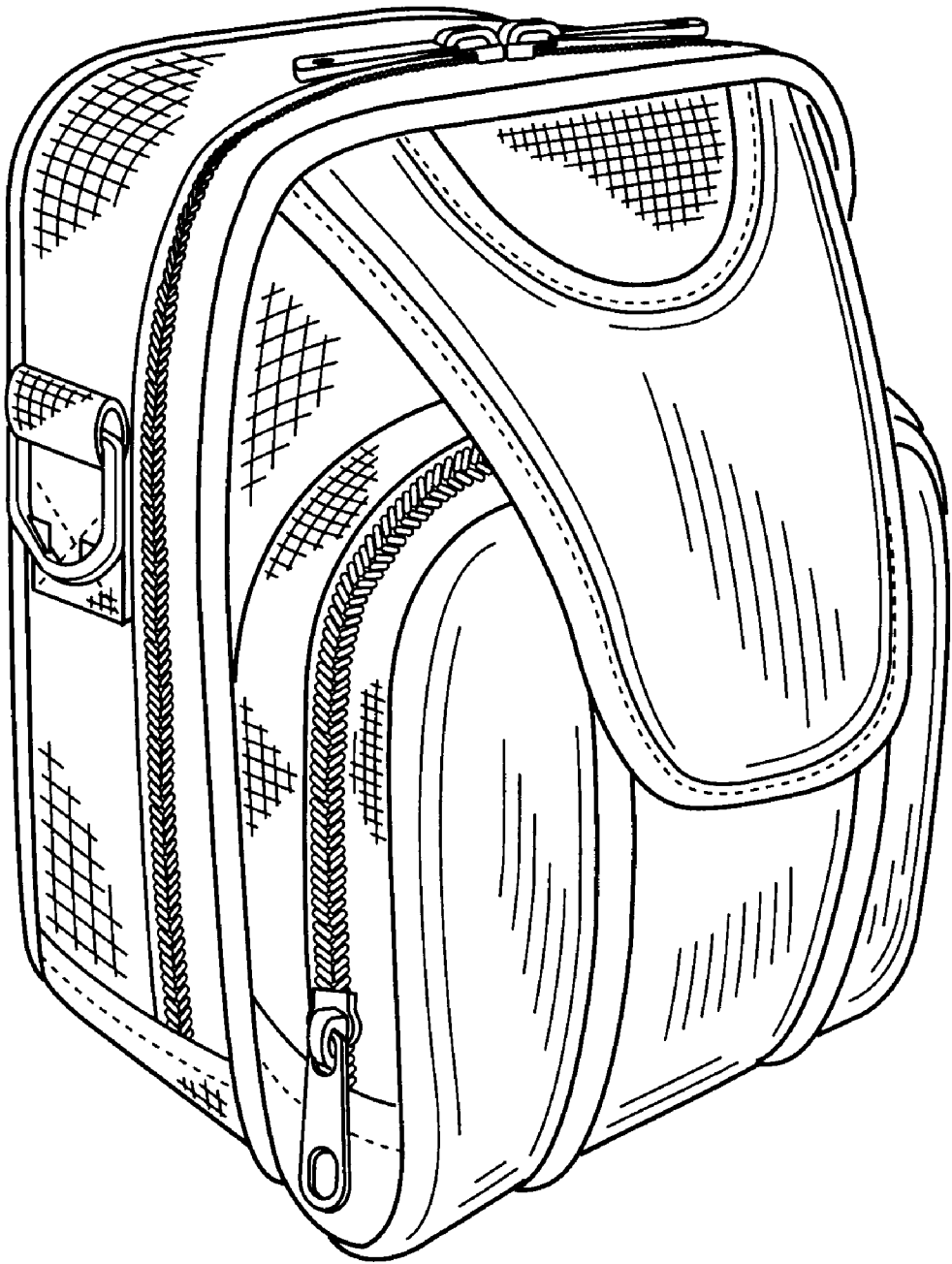

FIG. 8

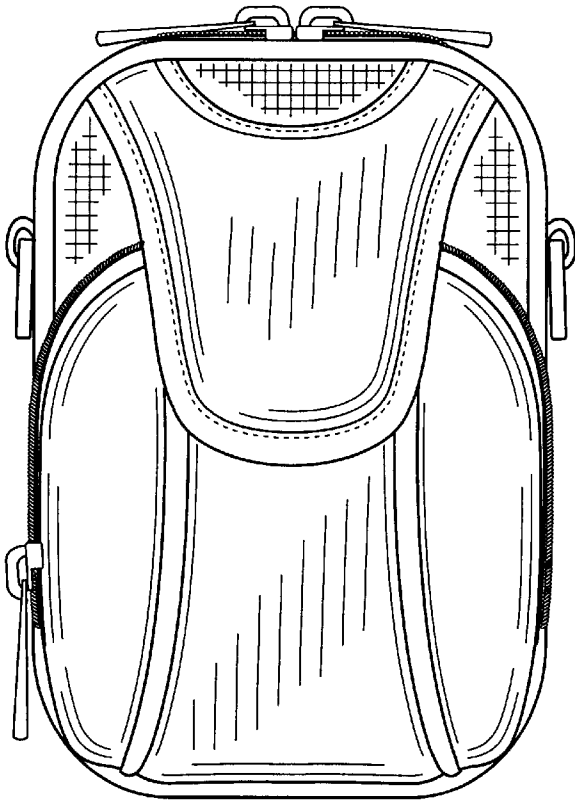

FIG. 9

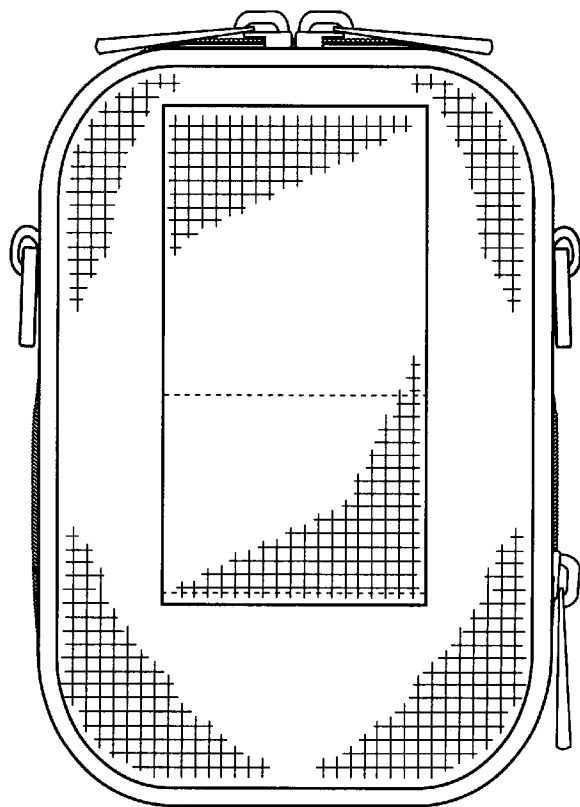

FIG. 10

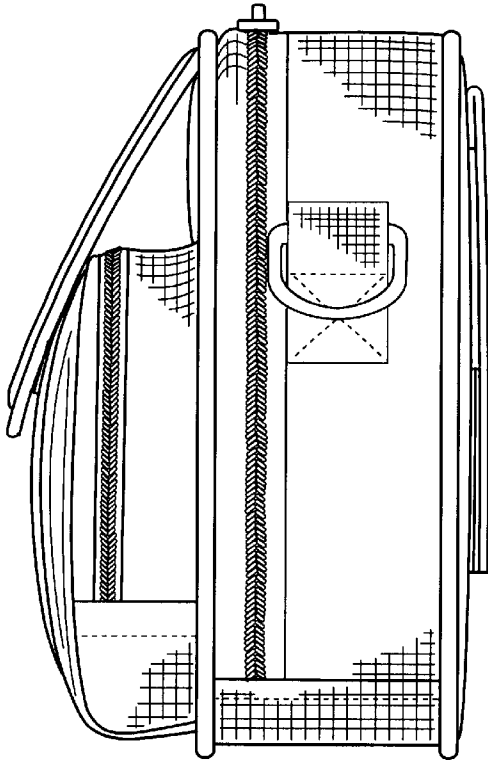
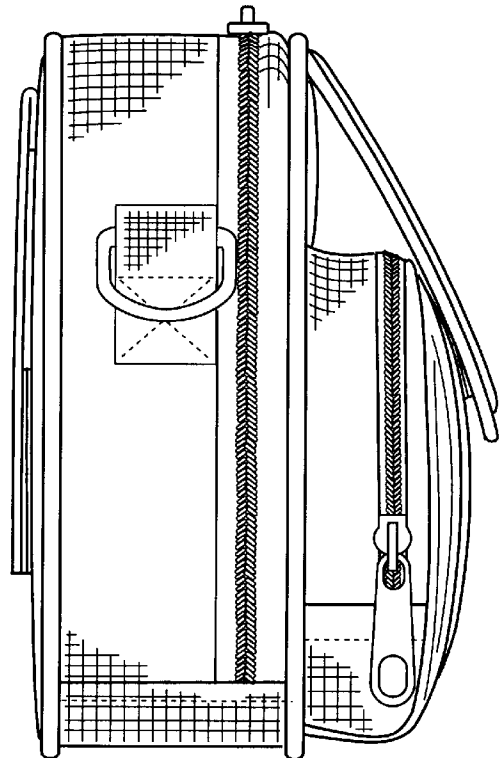

FIG. 11

FIG. 12





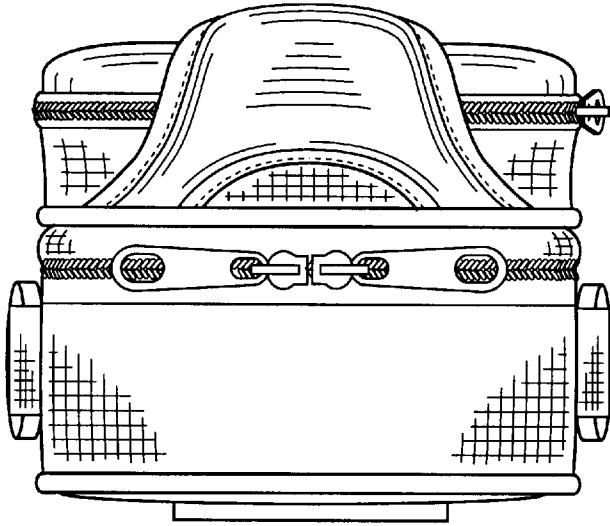

FIG. 13

FIG. 14

