

(19)



(11)

**EP 3 401 534 A1**

(12)

**EUROPEAN PATENT APPLICATION**

(43) Date of publication:  
**14.11.2018 Bulletin 2018/46**

(51) Int Cl.:  
**F02D 9/10 (2006.01) F02D 11/10 (2006.01)**

(21) Application number: **17465521.7**

(22) Date of filing: **10.05.2017**

(84) Designated Contracting States:  
**AL AT BE BG CH CY CZ DE DK EE ES FI FR GB GR HR HU IE IS IT LI LT LU LV MC MK MT NL NO PL PT RO RS SE SI SK SM TR**  
Designated Extension States:  
**BA ME**  
Designated Validation States:  
**MA MD**

(71) Applicant: **Continental Automotive GmbH**  
**30165 Hannover (DE)**

(72) Inventors:  

- **Albert, Eusebio-Marius**  
**300737 Timisoara (RO)**
- **Aronet, Vlad**  
**325300 Bocsa, Caras-Severin (RO)**

(54) **VALVE HAVING A THROTTLE FLAP ARRANGED IN A THROTTLE FLAP CONNECTOR**

(57) The invention relates to a valve for regulating a flow cross section in a throttle flap connector, having a throttle flap which is mounted in the throttle flap connector so as to be rotatable about an axis of rotation, wherein the throttle flap is rotatable about the axis of rotation, by means of an actuator which acts on the throttle flap, counter to a force generated by a mechanical spring, wherein the throttle flap, in at least a first position, is fixable in

said first position by means of a magnet device (4, 5), wherein the magnet device (4, 5) is formed by a permanent magnet (4) and a magnetic counterpart (5), wherein the permanent magnet (4) is arranged in the housing (1) of the throttle flap connector and the magnetic counterpart (5) is arranged on an element (2) which is rotatable with the throttle flap.

Fig. 1

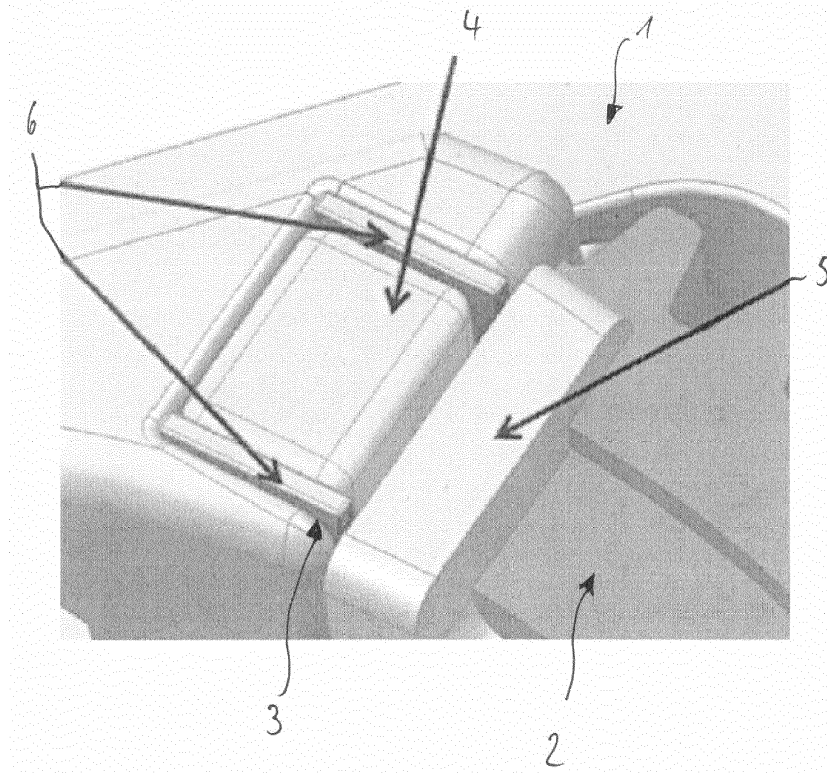

**EP 3 401 534 A1**

## Description

### Technical field

**[0001]** The invention relates to a valve for regulating a flow cross section in a throttle flap connector, having a throttle flap which is mounted in the throttle flap connector so as to be rotatable about an axis of rotation, wherein the throttle flap is rotatable about the axis of rotation, by means of an actuator which acts on the throttle flap, counter to a force generated by a mechanical spring.

### Prior art

**[0002]** Throttle flaps are used for example in the intake tract of internal combustion engines for the purposes of regulating the air quantity to be supplied to the combustion chamber. Through the use of a throttle flap, it is possible in particular for the supplied air quantity to be adapted to the supplied fuel quantity, and/or for an air-fuel mixture suitable for the respective load state of the internal combustion engine to be generated.

**[0003]** Throttle flaps in throttle flap connectors are known. DE 195 12 729 A1 describes a throttle flap connector with a tubular housing in which a throttle flap is fastened to a throttle flap shaft which, at its free ends led through recesses in the housing wall, is mounted so as to be rotatable transversely with respect to the longitudinal axis of the tubular housing.

**[0004]** Throttle flaps can be rotated in their throttle flap connector by means of an actuator, such as for example an electric motor. As a result of the rotation of the throttle flap relative to the throttle flap connector, the flow cross section of the throttle flap connector can be increased and decreased in size. Often, throttle flaps are designed so as to be held open by a mechanical spring when not acted on by the actuator. Here, the actuator is used to close the throttle flap, through the application of a force, counter to the spring force acting on said throttle flap.

**[0005]** A disadvantage of devices in the prior art is in particular that the closed position of the throttle flap can be maintained only if the actuator remains energized and thus exerts on the throttle flap a force which counteracts the force imparted by the mechanical spring.

**[0006]** Presentation of the invention, problem, solution, advantages

**[0007]** Therefore, the problem addressed by the present invention is that of creating a throttle flap arranged in a throttle flap connector, which throttle flap can be held in a defined position even in the presence of a reduced action of the actuator or in the absence of action of the actuator.

**[0008]** The problem is solved, with regard to the valve, by means of a valve having the features of claim 1.

**[0009]** An exemplary embodiment of the invention relates to a valve for regulating a flow cross section in a throttle flap connector, having a throttle flap which is mounted in the throttle flap connector so as to be rotat-

able about an axis of rotation, wherein the throttle flap is rotatable about the axis of rotation, by means of an actuator which acts on the throttle flap, counter to a force generated by a mechanical spring, wherein the throttle flap, in at least a first position, is fixable in said first position by means of a magnet device, wherein the magnet device is formed by a permanent magnet and a magnetic counterpart, wherein the permanent magnet is arranged in the housing of the throttle flap connector and the magnetic counterpart is arranged on an element which is rotatable with the throttle flap.

**[0010]** The valve is formed by a tubular throttle flap connector in which a throttle flap is rotatably mounted. As a result of the rotation of the throttle flap, the cross section, through which flow can pass, of the throttle flap connector can be increased or decreased in size. In the two maximum positions, the throttle flap completely respectively closes the flow cross section of the throttle flap connector or opens up the flow cross section of the throttle flap connector by being rotated so as to be oriented parallel to the main throughflow direction.

**[0011]** The throttle flap is acted on by a mechanical spring with a force which rotates the throttle flap either toward the open position or toward the closed position.

Furthermore, an actuator, for example an electric motor, is provided, which can exert on the throttle flap a force directed counter to the mechanical spring. Depending on the arrangement of the mechanical spring and of the actuator, the throttle flap can be either open or closed by means of the mechanical spring, wherein the actuator acts in each case in the opposite direction.

**[0012]** To be able to advantageously fix the throttle flap in a defined position, a magnet device is provided. Said first position is particularly preferably characterized by the fully closed position of the throttle flap or by the fully open position.

**[0013]** A permanent magnet is particularly advantageously arranged on the throttle flap connector, which permanent magnet magnetically interacts with a magnetic counterpart which is mounted on the throttle flap itself.

**[0014]** It is particularly advantageous if the permanent magnet is surrounded by means for directing the magnetic field, which means increase the magnetic force of the permanent magnet in at least one direction. Said means are advantageous for directing and focusing the magnetic field generated by the respective permanent magnet, in order to thereby achieve the same action with a smaller permanent magnet or to transmit the magnetic force over a greater distance.

**[0015]** It is also advantageous if the means for directing the magnetic field are formed by metal plates which are arranged between the permanent magnet and the housing of the throttle flap connector. Metal plates can, if produced from a magnetic metal, be utilized for directing and focusing the field lines originating from the permanent magnet. This is based on the magnetic characteristics of the metal.

**[0016]** It is furthermore advantageous if the means for

directing the magnetic field are formed by steel elements. Steel is particularly advantageous because it can be procured cheaply in an extremely wide range of variants and is furthermore easy to machine. In this way, the magnetic field can be influenced in a particularly simple manner.

**[0017]** A preferred exemplary embodiment is characterized in that the magnetic counterpart is movable on a circular path formed around the axis of rotation, wherein the spacing between the permanent magnet and the magnetic counterpart in a circumferential direction along the circular path is defined by the angle of rotation of the throttle flap. The arrangement of the permanent magnet and of the magnetic counterpart on a common circular path is advantageous for ensuring that the two elements can be moved toward one another or away from one another in a defined manner as a result of the rotation of the throttle flap. The circular path advantageously runs around the axis of rotation of the throttle flap.

**[0018]** It is also preferable if the housing of the throttle flap connector has a cutout which is open at least on one side and into which the permanent magnet and the means for directing the magnetic field are inserted. An arrangement of the permanent magnet on the housing of the throttle flap connector is advantageous because the permanent magnet is thus positionally fixed and is in particular not adversely affected by the inertia of the throttle flap.

**[0019]** It is furthermore advantageous if that side of the cutout which is open on one side is at least partially covered, in at least one position of the throttle flap, by the magnetic counterpart. The cutout is advantageously located such that the opening through which the permanent magnet is inserted can be partially or entirely covered by the magnetic counterpart. This is necessary in order to impart the best possible action on the magnetic counterpart, because the magnetic field lines can propagate unhindered through the opening.

**[0020]** It is also expedient if the magnetic counterpart is part of the toothed ring by means of which the movement of the actuator can be transmitted to the throttle flap. This is particularly advantageous because the toothed ring that is generally used for transmitting the movement of the actuator to the throttle flap moves in the same direction as, and in a manner directly dependent on, the throttle flap.

**[0021]** It is furthermore advantageous if the throttle flap is rotatable between two maximum positions, wherein, in the first maximum position, the throttle flap closes the flow cross section of the throttle flap connector, and in the second maximum position, the throttle flap opens up the flow cross section of the throttle flap connector.

**[0022]** It is furthermore expedient if the throttle flap, in the first position in which it is fixable by means of the magnet device, completely closes the flow cross section of the throttle flap connector. This is particularly advantageous if the throttle flap is constructed such that the mechanical spring opens the throttle flap and the actuator closes the throttle flap. Here, by means of the magnet

device, the throttle flap can be fixed in the closed position even when the actuator exerts no force, or only a reduced force, on the throttle flap.

**[0023]** It is also advantageous if the force generated by the magnet device for holding the throttle flap in the first position is at least equal to or greater than the force generated by the mechanical spring. This applies in particular if the magnetic device exerts a force which is directed counter to the force of the mechanical spring.

**[0024]** Advantageous refinements of the present invention are described in the subclaims and in the following description of the figures.

#### Brief description of the drawings

**[0025]** Below, the invention will be discussed in detail on the basis of an exemplary embodiment and with reference to the drawing, in which:

figure 1 shows a perspective view of the cutout into which the permanent magnet is inserted and the magnetic counterpart on the throttle flap, wherein the permanent magnet is encompassed by means for directing the magnetic field.

#### Preferred embodiment of the invention

**[0026]** Figure 1 shows a detail view of the housing 1 of the throttle flap connector and of the toothed ring 2, which transmits the movement of the actuator (not shown) to the throttle flap (likewise not shown).

**[0027]** The housing 1 has a cutout 3 which forms a receptacle for the permanent magnet 4. On the toothed ring 2, at the end region facing toward the cutout 3, there is arranged a magnetic counterpart 5 which can be moved toward the permanent magnet as a result of the rotation of the throttle flap about the axis of rotation.

**[0028]** The magnetic counterpart 5 is in particular manufactured from a magnetic material on which the magnetic force of the permanent magnet 4 can act when said magnetic counterpart enters the area of action of the magnetic field.

**[0029]** The permanent magnet 4 is encompassed laterally by plates 6 which serve for directing and focusing the magnetic field. By means of the plates 6, the magnetic field of the permanent magnet 4 can be directed so as to be oriented in the direction of the magnetic counterpart 5. This has the effect that the magnetic field extends over a greater distance than in the case of a permanent magnet without the plates. It is thus possible for the magnetic counterpart 5 to enter the area of action of the permanent magnets 4 at an earlier point in time, whereby the action is intensified.

**[0030]** By means of the permanent magnet 4, the magnetic counterpart 5 can be attracted, whereby the throttle flap connected to the magnetic counterpart 5 by means of the toothed ring 3 is also attracted, or is rotated further

about its axis of rotation. When the magnetic counterpart 5 comes into contact with the permanent magnet 4 or with the cutout 3, the movement of the throttle flap is delimited. The permanent magnet 4 or the cutout 3 thus act as a stop for the throttle flap. Depending on the positioning of the permanent magnet 4 or of the stop 3 relative to the position of the throttle flap or of the angle of rotation thereof, it is thus possible for an end position for the throttle flap to be defined. Here, in the end position thus defined, the throttle flap may for example completely close the flow cross section, completely open up said flow cross section, or assume a defined intermediate position.

**[0031]** The exemplary embodiment of figure 1 is in particular not of a restrictive nature, and serves for illustrating the concept of the invention.

### Claims

1. A valve for regulating a flow cross section in a throttle flap connector, having a throttle flap which is mounted in the throttle flap connector so as to be rotatable about an axis of rotation, wherein the throttle flap is rotatable about the axis of rotation, by means of an actuator which acts on the throttle flap, counter to a force generated by a mechanical spring, **characterized in that** the throttle flap, in at least a first position, is fixable in said first position by means of a magnet device (4, 5), wherein the magnet device (4, 5) is formed by a permanent magnet (4) and a magnetic counterpart (5), wherein the permanent magnet (4) is arranged in the housing (1) of the throttle flap connector and the magnetic counterpart (5) is arranged on an element (2) which is rotatable with the throttle flap.
2. The valve as claimed in claim 1, **characterized in that** the permanent magnet (4) is surrounded by means (6) for directing the magnetic field, which means increase the magnetic force of the permanent magnet (4) in at least one direction.
3. The valve as claimed in one of the preceding claims, **characterized in that** the means (6) for directing the magnetic field are formed by metal plates (6) which are arranged between the permanent magnet (4) and the housing (1) of the throttle flap connector.
4. The valve as claimed in one of the preceding claims, **characterized in that** the magnetic counterpart (5) is movable on a circular path formed around the axis of rotation, wherein the spacing between the permanent magnet (4) and the magnetic counterpart (5) in a circumferential direction along the circular path is defined by the angle of rotation of the throttle flap.
5. The valve as claimed in one of the preceding claims, **characterized in that** the housing (1) of the throttle flap connector has a cutout (3) which is open at least on one side and into which the permanent magnet (4) and the means (6) for directing the magnetic field are inserted.
6. The valve as claimed in one of the preceding claims, **characterized in that** that side of the cutout (3) which is open on one side is at least partially covered, in at least one position of the throttle flap, by the magnetic counterpart (5).
7. The valve as claimed in one of the preceding claims, **characterized in that** the means (6) for directing the magnetic field are formed by steel elements (6).
8. The valve as claimed in one of the preceding claims, **characterized in that** the magnetic counterpart (5) is part of the toothed ring (2) by means of which the movement of the actuator can be transmitted to the throttle flap.
9. The valve as claimed in one of the preceding claims, **characterized in that** the throttle flap, in the first position in which it is fixable by means of the magnet device (4, 5), completely closes the flow cross section of the throttle flap connector.
10. The valve as claimed in one of the preceding claims, **characterized in that** the force generated by the magnet device (4, 5) for holding the throttle flap in the first position is at least equal to or greater than the force generated by the mechanical spring.

Fig. 1

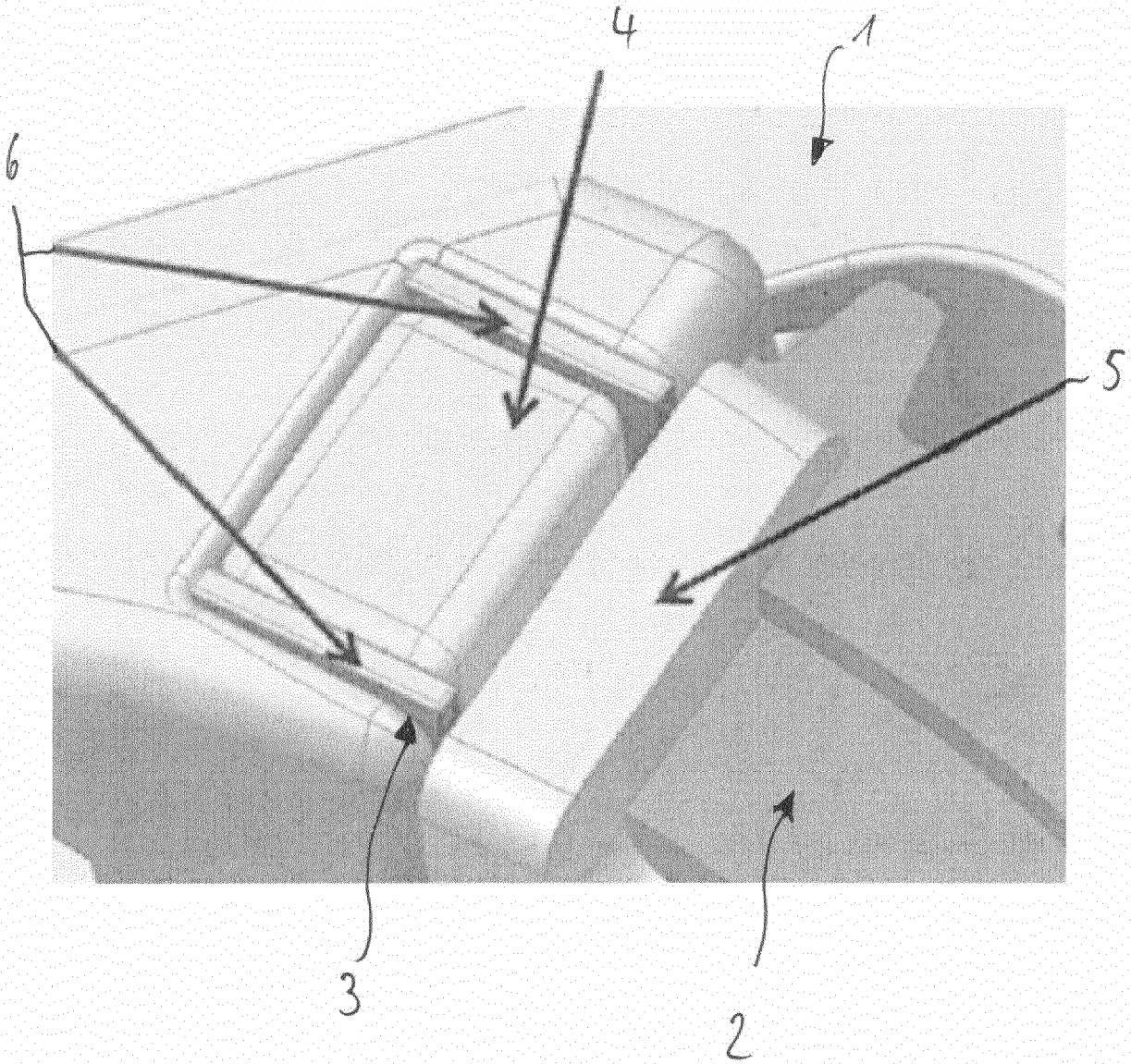



EUROPEAN SEARCH REPORT

Application Number  
EP 17 46 5521

5

DOCUMENTS CONSIDERED TO BE RELEVANT			
Category	Citation of document with indication, where appropriate, of relevant passages	Relevant to claim	CLASSIFICATION OF THE APPLICATION (IPC)
10 Y	US 6 779 775 B2 (A B ELEKTRONIK GMBH [DE]) 24 August 2004 (2004-08-24) * column 3, line 64 - column 6, line 7; figures 1-7 *	1-10	INV. F02D9/10 F02D11/10
15 Y	DE 101 43 835 A1 (PIERBURG GMBH [DE]) 27 March 2003 (2003-03-27) * paragraph [0009] - paragraph [0013]; figures 1-2 *	1-10	
20 Y	GB 2 232 274 A (PEI QUI MAO [CN]; JING GAN; BING HUANG QUE) 5 December 1990 (1990-12-05) * page 3, line 7 - page 6, line 8; figures 1-3 *	1-10	
25 Y	JP H10 160027 A (NISSAN MOTOR) 16 June 1998 (1998-06-16) * paragraph [0005] - paragraph [0015]; figures 1-7 *	1-10	
30 Y	US 5 092 296 A (GUENTER SPIEGEL [DE] ET AL) 3 March 1992 (1992-03-03) * column 2, line 11 - column 5, line 20; figures 1-2 *	1-10	
The present search report has been drawn up for all claims			TECHNICAL FIELDS SEARCHED (IPC)
			F02D
1	Place of search	Date of completion of the search	Examiner
50	The Hague	29 November 2017	Raposo, Jorge
55	CATEGORY OF CITED DOCUMENTS		T : theory or principle underlying the invention E : earlier patent document, but published on, or after the filing date D : document cited in the application L : document cited for other reasons ..... & : member of the same patent family, corresponding document
	X : particularly relevant if taken alone Y : particularly relevant if combined with another document of the same category A : technological background O : non-written disclosure P : intermediate document		

EPO FORM 1503 03/02 (P04C01)

ANNEX TO THE EUROPEAN SEARCH REPORT  
ON EUROPEAN PATENT APPLICATION NO.

EP 17 46 5521

5

This annex lists the patent family members relating to the patent documents cited in the above-mentioned European search report. The members are as contained in the European Patent Office EDP file on  
The European Patent Office is in no way liable for these particulars which are merely given for the purpose of information.

29-11-2017

10

15

20

25

30

35

40

45

50

55

Patent document cited in search report	Publication date	Patent family member(s)	Publication date
US 6779775 B2	24-08-2004	DE 10235049 A1	19-02-2004
		EP 1387064 A2	04-02-2004
		US 2004021106 A1	05-02-2004
-----			
DE 10143835 A1	27-03-2003	NONE	
-----			
GB 2232274 A	05-12-1990	CN 1037381 A	22-11-1989
		DE 3936992 A1	06-12-1990
		GB 2232274 A	05-12-1990
		JP H039182 A	17-01-1991
		US 5009388 A	23-04-1991
-----			
JP H10160027 A	16-06-1998	NONE	
-----			
US 5092296 A	03-03-1992	DE 4022825 A1	28-02-1991
		EP 0439577 A1	07-08-1991
		JP H04501300 A	05-03-1992
		US 5092296 A	03-03-1992
		WO 9102891 A1	07-03-1991
-----			

**REFERENCES CITED IN THE DESCRIPTION**

*This list of references cited by the applicant is for the reader's convenience only. It does not form part of the European patent document. Even though great care has been taken in compiling the references, errors or omissions cannot be excluded and the EPO disclaims all liability in this regard.*

**Patent documents cited in the description**

- DE 19512729 A1 [0003]