

(19) World Intellectual Property Organization
International Bureau



(43) International Publication Date
13 June 2002 (13.06.2002)

PCT

(10) International Publication Number
WO 02/46080 A1

- (51) International Patent Classification⁷: **B65H 75/34**, 75/36
- (74) Agents: **JACOB, SHEENA R.** et al.; Alban Tay Mahtani & De Silva, 39 Robinson Road, #07-01 Robinson Point, Singapore 068911 (SG).
- (21) International Application Number: PCT/SG01/00246
- (22) International Filing Date: 4 December 2001 (04.12.2001)
- (81) Designated States (*national*): AE, AG, AL, AM, AT, AU, AZ, BA, BB, BG, BR, BY, BZ, CA, CH, CN, CO, CR, CU, CZ, DE, DK, DM, DZ, EC, EE, ES, FI, GB, GD, GE, GH, GM, HR, HU, ID, IL, IN, IS, JP, KE, KG, KP, KR, KZ, LC, LK, LR, LS, LT, LU, LV, MA, MD, MG, MK, MN, MW, MX, MZ, NO, NZ, PL, PT, RO, RU, SD, SE, SG, SI, SK, SL, TJ, TM, TR, TT, TZ, UA, UG, US, UZ, VN, YU, ZA, ZW.
- (25) Filing Language: English
- (26) Publication Language: English
- (30) Priority Data: 200006848-6 5 December 2000 (05.12.2000) SG
- (84) Designated States (*regional*): ARIPO patent (GH, GM, KE, LS, MW, MZ, SD, SL, SZ, TZ, UG, ZM, ZW), Eurasian patent (AM, AZ, BY, KG, KZ, MD, RU, TJ, TM), European patent (AT, BE, CH, CY, DE, DK, ES, FI, FR, GB, GR, IE, IT, LU, MC, NL, PT, SE, TR), OAPI patent (BF, BJ, CF, CG, CI, CM, GA, GN, GQ, GW, ML, MR, NE, SN, TD, TG).
- (71) Applicant (*for all designated States except US*): **SINGAPORE GENERAL HOSPITAL PTE LTD.** [SG/SG]; #07-00 SNEC Building, 11 Third Hospital Avenue, Singapore 168751 (SG).
- (72) Inventor; and
- (75) Inventor/Applicant (*for US only*): **HWANG, Nian, Chih** [SG/SG]; 52 Hillcrest Road, Singapore 288923 (SG).

[Continued on next page]

(54) Title: WINDING DEVICE

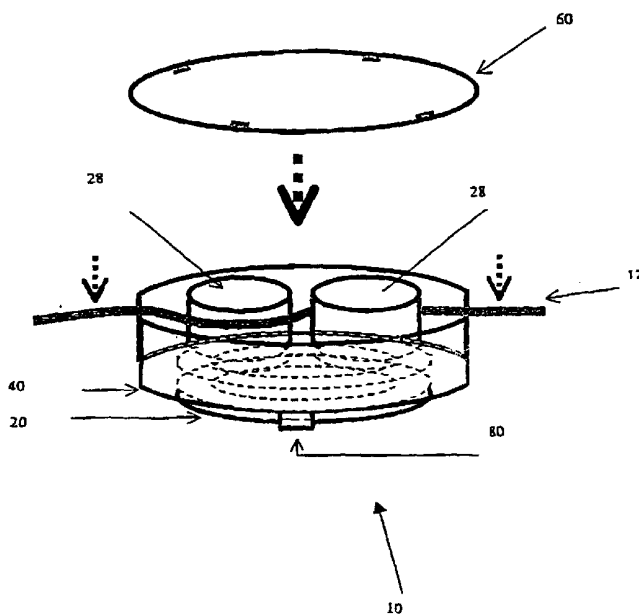

(57) Abstract: A winding device (10) for infusion tubing (12) is able to adjust the effective length of the infusion tubing (12) by winding one or more coils of tubing within the device (10), while discouraging the tubing (12) from becoming kinked and, accordingly, disrupting the flow of fluid through the tubing (12). A base member (20), rotatable within a casing member (40), has two winding projections (28) between which the infusion tubing (12) can be registered so that the effective length of the tubing (12) can be adjusted, when the base member (20) is rotated. An inhibiting means (80) selectively permits and prevents rotation of the base member (20).



WO 02/46080 A1

**Declarations under Rule 4.17:**

- as to applicant's entitlement to apply for and be granted a patent (Rule 4.17(ii)) for the following designations AE, AG, AL, AM, AT, AU, AZ, BA, BB, BG, BR, BY, BZ, CA, CH, CN, CO, CR, CU, CZ, DE, DK, DM, DZ, EC, EE, ES, FI, GB, GD, GE, GH, GM, HR, HU, ID, IL, IN, IS, JP, KE, KG, KP, KR, KZ, LC, LK, LR, LS, LT, LU, LV, MA, MD, MG, MK, MN, MW, MX, MZ, NO, NZ, PL, PT, RO, RU, SD, SE, SG, SI, SK, SL, TJ, TM, TR, TT, TZ, UA, UG, UZ, VN, YU, ZA, ZW, ARIPO patent (GH, GM, KE, LS, MW, MZ, SD, SL, SZ, TZ, UG, ZM, ZW), Eurasian patent (AM, AZ, BY, KG, KZ, MD, RU, TJ, TM), European patent (AT, BE, CH, CY, DE, DK, ES, FI, FR, GB, GR, IE, IT, LU, MC, NL, PT, SE, TR), OAPI patent (BF, BJ, CF, CG, CI, CM, GA, GN, GQ, GW, ML, MR, NE, SN, TD, TG)
- as to the applicant's entitlement to claim the priority of the earlier application (Rule 4.17(iii)) for the following designations AE, AG, AL, AM, AT, AU, AZ, BA, BB, BG, BR, BY, BZ, CA, CH, CN, CO, CR, CU, CZ, DE, DK, DM, DZ, EC,

EE, ES, FI, GB, GD, GE, GH, GM, HR, HU, ID, IL, IN, IS, JP, KE, KG, KP, KR, KZ, LC, LK, LR, LS, LT, LU, LV, MA, MD, MG, MK, MN, MW, MX, MZ, NO, NZ, PL, PT, RO, RU, SD, SE, SG, SI, SK, SL, TJ, TM, TR, TT, TZ, UA, UG, UZ, VN, YU, ZA, ZW, ARIPO patent (GH, GM, KE, LS, MW, MZ, SD, SL, SZ, TZ, UG, ZM, ZW), Eurasian patent (AM, AZ, BY, KG, KZ, MD, RU, TJ, TM), European patent (AT, BE, CH, CY, DE, DK, ES, FI, FR, GB, GR, IE, IT, LU, MC, NL, PT, SE, TR), OAPI patent (BF, BJ, CF, CG, CI, CM, GA, GN, GQ, GW, ML, MR, NE, SN, TD, TG)

- of inventorship (Rule 4.17(iv)) for US only

Published:

- with international search report

For two-letter codes and other abbreviations, refer to the "Guidance Notes on Codes and Abbreviations" appearing at the beginning of each regular issue of the PCT Gazette.

WINDING DEVICE

Field of the invention

The invention relates to the use of infusion tubing and relates particularly, though not exclusively, to the use of infusion tubing of the type used for treating patients in
5 medical facilities.

Background of the invention

It has been conventional practice for some time in medical facilities to use infusion therapy to deliver fluids to patients under treatment. Infusion therapy involves the use of infusion tubing, and infusion pumps or bottles, to allow intravenous delivery
10 of solutions of various kinds to the patient.

It is not always practicable to position the infusion pumps or bottles directly adjacent to a patient for whom they are intended. Accordingly, medical-grade infusion tubing is commercially supplied in lengths typically in the range of 150 cm to 200 cm, which is sufficient for use in most usual circumstances. However, it is
15 typical that infusion pumps or bottles can be provided, for example, alongside a patient's bed. As a result, the infusion tubing is in practice generally of unnecessary length, which can present particular problems.

If the infusion tubing is longer than necessary, it can get in the way of other equipment, and inconvenience those attending to the patient. There is an
20 increased risk that the tubing may become kinked, compromising or potentially interrupting the flow of fluid to the patient.

Further, similar limitations become apparent when it is necessary to transport the patient who is under infusion therapy. Infusion tubing can become tangled and, undesirably, caught on something during transport, possibly damaging equipment
25 or distressing the patient.

To address these problems, it is usual practice to coil tubing to the desired length

and hold the coils together with adhesive tape. Depending on the type of adhesive tape used, uncoiling the infusion tubing can be difficult and time-consuming. Also, the effective length of the infusion tubing cannot be readily or conveniently adjusted.

- 5 It is an object of the invention to at least attempt to address these and other limitations of the existing prior art.

Summary of the invention

The inventive concept resides in a recognition that the use of infusion tubing can be desirably improved by providing a winding device which is able to adjust the
10 effective length of the infusion tubing by winding one or more coils of tubing within the device, while preferably discouraging or substantially preventing the tubing from becoming kinked.

Accordingly, the invention provides a winding device for use in adjusting the effective length of a length of tubing, the device including:

- 15 a rotatable base member having a platform from which project two winding projections; and

a casing member having a circumferential sidewall having two slots in opposing locations around the periphery of the sidewall;

- 20 wherein said base member and casing member are engageable for relative rotation whereby a length of infusion tubing can be registered within the opposing slots of the casing member and passed between the two winding projections, to enable adjustment of the effective length of the infusion tubing by rotating the base of the winding device relative to the casing member; and

- 25 wherein said device further includes means to inhibit said relative rotation when the length of tubing is not being adjusted.

Preferably, the winding device further includes a cover member able to be secured

to said casing member to close the winding device. Preferably, the surface of the cover member coincides with an upper surface of the two winding projections, to retain infusion tubing wound around the winding projections. Preferably, the cover member is substantially translucent or transparent, so that the tubing wound within
5 the winding device can be readily observed.

Preferably, an inner surface of the winding projections can be accessed through the casing member to allow for convenient manual rotation of the base member. Preferably, two fingers are used in respective projections to wind the infusion tubing.

10 Preferably, the inhibiting means comprises a locking mechanism which is integral with the casing and is positioned under the casing. Preferably, the locking mechanism involves two reciprocable members that are selectively engageable with the slots in the sidewall, as required, when the slots coincide with the members due to rotation of the base.

15 In another embodiment, the inhibiting means comprises corresponding detent portions and engaging portions respectively located on the base member and casing member. Engagement and disengagement of the detent portions and engaging portions respectively substantially opposes and permits rotation of the base member.

20 The base member, in a further embodiment includes a grip member which locks with the base member whilst engaging with the exterior of the casing member. Moreover, the corresponding detent portions and engaging portions are respectively located on the grip member and casing member such that respective engagement and disengagement of the detent portions and engaging portions
25 substantially opposes and permits rotation of the base member.

Preferably, chamfer portions are included on the perimeter of the grip member to assist a user to grip and rotate the grip member and locked base member relative to the casing member.

Preferred embodiments of the invention will now be described, by way of example only, with reference to the accompanying drawings.

Description of drawings

Fig. 1 is a perspective view of a winding device constructed in accordance with an embodiment of the invention.

Figs. 2 to 5 are respectively top, side, bottom and side perspective views of a base member of the winding device shown in Fig. 1.

Figs. 6 to 9 are respectively top, side, bottom and side perspective views of a casing member of the winding device shown in Fig. 1.

Fig. 10 is a base view of a cover piece of the winding device shown in Fig. 1.

Figs. 11 and 12 are base views of the winding device shown in Fig. 1 when a locking mechanism is respectively enabling and preventing rotation of the base member.

Figs. 13 and 14 are perspective views of the locking mechanism of Figs. 11 and 12 when respectively enabling and preventing rotation of the base member.

Figs 15 to 17 are respectively a perspective view, underneath plan view and side elevation view along the line A-A in Fig 16 of a base member in accordance with a further embodiment of the invention.

Figs 18 to 20 are respectively a perspective view, a side elevation view along the line A-A in Fig 20 and a top plan view of a casing member in accordance with the further embodiment.

Figs 21 to 24 depict respectively a top plan view, cross-section view along the line B-B in Fig 21, bottom perspective view and top perspective view of a grip member in accordance with the further embodiment of the invention.

Figs 25 to 27 illustrate respectively a bottom plan view, a cross-section view along the line A-A in Fig 25 and bottom perspective view of a cover member in accordance with the further embodiment.

Fig 28 is an exploded perspective view of the device in accordance with the further
5 embodiment, excluding the cover member.

Description of preferred embodiments

A first embodiment of the invention is described in relation to a winding device 10, illustrated in Figs 1 to 14, of which is used for the purpose of adjusting the effective length of a length of infusion tubing 12, by winding a portion of the tubing 12 within
10 the winding device 10. Figs 15 to 28 show a second embodiment of the winding device 10 which is also used to adjust the effective length of a length of infusion tubing 12 in the same manner as the first embodiment.

Referring to the first embodiment, the winding device 10 includes a base member 20, a casing member 40 and a locking mechanism 80. A cover member 60 is
15 provided to enclose the tubing 12 within the winding device 10. The components of the locking mechanism 80 are respectively disposed on the base member 20 and casing member 40.

The base member 20 is illustrated more particularly in Figs. 2 to 5. The base member 20 includes an upper platform 22 and a lower support 24, which are both
20 of generally elliptical profile as indicated in the drawings. The platform 22 and support 24 are integrally joined by a pillar 26, which is centrally located on the platform 22 and support 24 as shown. Two projections 28, which are both of equal size and generally circular in cross-sectional profile, project upwardly from the platform 22. The two projections 28 are positioned along the major dimension of
25 the platform 22. The size and profile of the platform 22 is such that it is able to comfortably accommodate both cylindrical projections 28 within its periphery.

Another major component of the winding device 10 is the casing member 40, shown in Figs. 6 to 9. The casing member 40 has an annular base ring 42 which is

integral with a circumferential sidewall 44 extending around the outer periphery of the annular base ring 42. The casing member 40 is generally circular in cross-sectional profile and the sidewall 44 is of sufficient circumference to accommodate the elliptically-shaped base member 20, through its full range of rotation within the casing member 40. On opposing sides of the sidewall 44 there are included respective slots 46 that extend the full length of the sidewall 44, for admitting infusion tubing as described below.

The base member 20 is formed from an elastomer, or other suitable material, which enables the lower support 24 of the base member 20 to be deformed and thereby forced through the central aperture in the annular base ring 42. Once through the aperture, with the pillar 26 surrounded by the inner perimeter of the annular base ring 42, the lower support 24 returns to its elliptical shape. Accordingly, the base member 20 is retained in engagement with the casing member 40 by the sandwiching of the annular base ring 42 between the platform 22 and lower support 24 of the base member 20. The material from which the base member 20 is formed is such as to prevent the base member 20 from disengaging with the casing member 40 and the projections 28 from substantially deforming under normal operating conditions.

A cover member 60, as illustrated in Fig. 10, includes peripheral lugs 62 disposed around the periphery of the cover member 60 that enable it to register with the upper edge of the sidewall 44 of the casing member 40. The cover member 60 provides a lid for the casing member 40, yet still enables the tubing disposed within the casing member 40 to be seen by a user, as the cover member 60 is made of a translucent material, such as high density polyethylene.

A locking mechanism 80 is provided by components disposed on both the base member 20 and the casing member 40. Figs. 11 to 14 illustrate the locking mechanism, alternatively represented as part of the winding device 10, or in isolation, when respectively permitting and preventing rotation of the base member 20 within the casing member 40. The locking mechanism 80 includes opposing base notches 82 on the support 24 of the base member 20, and matching casing notches 84 on the annular base ring 42 of the casing member 40. The base

notches 82 extend directly into the support 24 of the base member 20, and are located at opposing ends of the support 24, along its major dimension. The casing notches 84 are of equal size and extend directly into the annular base ring 42 from its inner edge, at diametrically opposite positions on the casing member 40.

5 Slideable within both the base notches 82 and the casing notches 84 are respective reciprocable locking bars 86. The side walls of both the base notches 82 and the casing notches 84, and the corresponding sides of the locking bars 86 are all outwardly tapered into the base member 20 and casing member 40 and so exhibit a dovetail cross-section, whereby the bars 86 are retained within the
10 notches 82, 84 as shown. The locking mechanism 80 operates by allowing the base member 20 to freely rotate relative to the casing member 40 when the bars 86 are withdrawn and are fully housed within the casing notches 84. However, when the base notches 82 are aligned with the casing notches 84, the bars 86 can be moved radially inwards from the casing notches 84 into the base notches 82 by
15 manually grasping a depending tab 87 so that the bars 86 bridge the two notches, as shown in Figures 12 and 14. The base member 20 is now prevented from further rotating due to the blocking action of the bars 86. Webs 89 (Figure 14) across the ends of the mouth of each slot 84 act as a stop for tab 87 and so ensure that the bars 86 do not disengage from the casing notches 84. Desirably, a
20 biasing element is also provided to return the bars 86 to the casing notches 84 when the bars 86 are not positively engaged within the base notches 82.

The winding device 10 is preferably used in the following manner. An intermediate portion of a length of infusion tubing 12 is registered within slots 46 provided in the sidewall 44 of the casing member 40. This intermediate portion of the infusion
25 tubing 12 is also passed between the two projections 28. Accordingly, if the projections 28 are initially aligned with the slots 46, the infusion tubing 12 passes through the winding device in a serpentine or "S"-shape, as shown in Fig. 1.

Once the infusion tubing 12 has been placed in the winding device 10 as described, the cover member 60 is attached to the casing member 40 by securing
30 it to the upper edge of the sidewall 44 using the peripheral lugs 62. The inner or lower surface of the cover member 60 abuts the top surface of the two projections

28 so that there is only minimal clearance, if any, between these surfaces. This assists in ensuring that the infusion tubing 12 remains wound around the two projections 28. On the other side of the winding device 10, fingers can be used to manually manipulate the inner surfaces of the two projections 28 to rotate the base member 20 within the casing member 40. As the slots 46 in the sidewall 44 are fixed, and the two projections 28 of the base member 20 rotate within the casing member 40, the infusion tubing can be wound around the two projections 28. This reduces the effective length of the infusion tubing 12 as progressively more of the tubing 12 is admitted to both of the slots 46. Having wound a certain amount of tubing 12 within the winding device 10, adjustments can be made by rotating the base member 20 in the opposing direction to begin releasing some of the wound tubing 12.

Once the desired effective length of the infusion tubing is achieved the locking mechanism 80 can be used as described above, to prevent further rotation of the base member 20 relative to the casing member 40, and hence any further adjustment of the effective length of the infusion tubing 12. When an adjustment is required, the locking mechanism 80 can be released to allow for free rotation of the base member 20.

Referring now to the second embodiment, the winding device 10 comprises a base member 20 with a grip portion 100, a casing 40 and a cover 60.

The casing 40 shown in Fig 18 has an annular base ring 42 with a side wall 44 around the outer perimeter of the base ring 42. Slots 46, in the form of a U-shape, are included in the side wall 44 in opposed locations. The base ring 42 also has a lower ring 94 attached to the underside of the inner perimeter of the base ring 42 to form a lower platform 95. The lower ring 94 has an inner diameter slightly less than the inner diameter of the base ring 42 and, accordingly, the lower platform 95 runs around the inner perimeter of the base ring 42.

A groove 90 is included on the outer surface 92 of the side wall 44, as shown in Figs 18 and 19, and is adapted to receive a corresponding bead 128 which runs around the inside of a rim 126 on the cover 60 (Figs 26 and 27).

The side elevation view of the casing 40 depicted in Fig 19 also shows protuberances 98 located on the underside of the base ring 42. The purpose of these protuberances 98 will be described in detail at a later stage. As shown in Fig 20, four protuberances 98 are equally spaced at 90° intervals around the base ring 42 according to this embodiment, however, alternative embodiments may also include more or less protuberances. Preferably each protuberance 98 is shaped as a spherical dome but they equally may take other shapes.

The base 20 (Figures 15 to 17) comprises a circular disc 138 with a hole 130 at its centre and two projections 28, each located on opposed sides of the hole 130 and formed in the same manner as described in relation to the first embodiment. The diameter of the disc 138 is slightly less than the inner diameter of the base ring 42 and slightly greater in diameter than the lower ring 94. In this manner, the base 20, when placed inside the casing 40, is adapted to rotate freely whilst sitting on the platform 95 with the top surface of the ring being substantially flush with the upper surface of the base ring 42.

Fig 16 depicts the underneath surface 136 of the base 20. The surface 136 includes two cavities 134 which define the interior of the projections 28 and two lugs 132 on opposed sides of the hole 130 but offset angularly with respect to the cavities 134. The relative size of the projections 28 and lugs 134 is shown in Fig 17.

Figures 21 and 24 respectively show plan and perspective views of the top of a grip portion 100 which comprises a circular disc with a raised outer rim 109. The rim 109 has detent recesses 108 which are shaped correspondingly to the protuberances 98 on the casing 40 and located on the inner dimension of the rim 109. According to this embodiment, there are twenty-four equally spaced detent recesses 108 on the grip portion 100, but, again, there may be more or less as desired, for example eight to twelve.

The grip portion 100 also has two rings 104 raised above the surface 118 of the grip portion 100 and positioned such that a central well 112, defined by each raised ring 104, corresponds with the location of a respective one of the lugs 132

on the base 20. Furthermore, two apertures 102 are located on opposed sides of a resiliently deformable pin 106 in the centre of the grip portion 100. The perimeter 122 of each aperture has a diameter which is equal to the diameter of the cavity 134 of each projection 28 and is raised above the surface 118 by an amount equal to the height of the rim 109 and rings 104.

Figs 22 and 24 show that the pin 106 comprises two opposed arcuate sections 114 separated by a gap 115, such that the sections 114 may be resiliently deformed into the gap 115. In an alternative embodiment, the pin 106 may be formed from three or more arcuate sections, each separated by a gap, which collectively define a circular tube. The distal end of each section 114 includes, on an outer surface, a lip 116. Furthermore, grips 110 are disposed around the perimeter of the grip portion 100. The grips 110 are formed as curved chamfer sections to assist a user to grasp the grip portion 100.

The winding device 10, according to the second embodiment in Fig 28, is assembled by seating the base 20 on the platform 95 in the casing 40. The grip portion 100 is brought together with the base member 20 to engage through the central aperture in the annular base ring 42. In doing so, the lugs 132 on the base 20 are aligned with the wells 112 on the grip portion 100 and the apertures 102 align with the cavities 134. The resilient pin 106 is then forced through the hole 130 in the base 20 to lock with the base 20. In doing so, the lugs 132 engage with the wells 112 on the grip portion 100 and the rim 109 contacts the underneath of the base ring 42 whilst the raised rings 104 and perimeters 122 contact the underneath surface 136 of the base 20.

The lower ring 94 of the casing 40 becomes clamped between the base 20 and grip portion 100 such that the protuberances 98 on the casing 40 firmly engage the inner edge of the rim 109 to generate friction and, thereby, inhibit rotation of the base 20 and locked grip portion 100, eg. the functional resistance is sufficient to prevent unwinding of the tubing from projections 28 arising from the resilience of the wound tubing. Preferably the detent recesses 108 and protuberances 98 are arranged such that upon incremental rotation of the base 20 and grip portion 100 relative to the casing 40 through a set angle, each protuberance 98 engages a

respective detent recess 108 at the same time. The resistance to rotation generated by the engagement of the protuberances 98 and detent recesses 108 is sufficient to substantially prevent rotation of the base 20 and grip portion 100 such that they become locked in that position. The protuberances 98 and detent
5 recesses 108 remain in the locked position until the base 20 and grip portion 100 are further rotated by overcoming that resistance, whereon the protuberances 98 are disengaged from their respective detent recesses 108 such that the protuberances 98 run along the inner edge of the rim 109 on the grip portion 100.

The device 10, according to the second embodiment, operates in the same
10 manner as described in respect of the first embodiment to reduce or adjust the length of a length of infusion tubing 12. Furthermore, a cover 60 may be placed over the casing 40 and base 20. The cover 60 shown in Figs 27 is formed as a shallow circular dish with a rim 126 which includes a bead 128 around its inner perimeter. The bead 128 is adapted to correspond with the groove 90 on the
15 casing 40 such that the cover 60 is retained on the casing 40 by the engagement of the bead 128 with the groove 90. Small blocks 124 are located on opposed sides of the cover 60 and are adapted to register with the slots 46 in the casing 40 to prevent rotation of the cover relative to the casing 40.

The components of the winding device 10 are, preferably, formed from high
20 density polypropylene but any appropriate material may be employed, eg such as high density polyethylene. Desirably, the base member 20 and the casing member 40 snugly engage, and are manufactured of materials having a low coefficient of surface friction to allow for easy relative movement of the surfaces of these respective members 20, 40. As mentioned above, the cover member 60 is
25 preferably transparent to allow a clear view of the infusion tubing within the winding device 10. The external surface of the cover member 60 can be labelled as required.

Infusion tubing 12 that is commercially supplied has a variety of external diameters, typically ranging from around 2mm to around 5mm. It is preferred that
30 the winding device 10 be provided in two sizes, to cater for infusion tubing towards respective ends of this range of sizes. These two sizes of winding device 10 allow

for different volumes of coiled tubing to be accommodated around the projections 28. In some cases, the slots 46 can be made relatively long and narrow, and the projections 28 made correspondingly relatively tall, to enable a number of different infusion tubes to be placed adjacently within the slots 46 so that their lengths can be correspondingly adjusted by rotation of the base member 20. This may be convenient when a patient is receiving infusion therapy using a number of different tubing arrangements of the same length from a number of different apparatus.

CLAIMS

1. A winding device for use in adjusting the effective length of a length of tubing, the device including:

5 a rotatable base member having a platform from which project two winding projections; and

a casing member having a circumferential sidewall having two slots in opposing locations around the periphery of the sidewall;

wherein said base member and casing member are engageable for relative rotation whereby a length of infusion tubing can be registered within the
10 opposing slots of the casing member and passed between the two winding projections, and the effective length of the infusion tubing adjusted by rotating the base member of the winding device relative to the casing member; and

wherein said device further includes means to inhibit said relative rotation
15 when the length of the tubing is not being adjusted.;
2. A winding device as claimed in claim 1, wherein an inner surface of the winding projections can be accessed through the casing member to allow for manual rotation of the base member relative to the casing member.
3. A winding device as claimed in claim 1 or 2, wherein the inhibiting means is
20 integrated with the base member and the casing member.
4. A winding device as claimed in any of the preceding claims, wherein said inhibiting means comprises a locking mechanism able to selectively enable and prevent rotation of the base member.
5. A winding device as claimed in claim 4, wherein the locking mechanism
25 involves two reciprocable members that are selectively engageable with respective notches in both the base member and the casing member to

prevent relative rotation of the base member and the casing member.

6. A winding device as claimed in claim 3, wherein the inhibiting means comprises corresponding detent portions and engaging portions respectively located on the base member and casing member whereby
5 respective engagement and disengagement of the detent portions and engaging portions substantially opposes and permits rotation of the base member.
7. A winding device as claimed in claim 3, wherein the base member includes
10 a grip member which locks with the base member whilst engaging with the exterior of the casing member.
8. A winding device as claimed in claim 7, wherein the inhibiting means
15 comprises corresponding detent portions and engaging portions respectively located on the grip member and casing member whereby
 respective engagement and disengagement of the detent portions and
 engaging portions substantially opposes and permits rotation of the base
 member.
9. A winding device as claimed in claim 7 or 8, wherein the grip member locks
20 with the base member by way of a number of lugs on the base member
 locating in corresponding recesses in the grip member and a resiliently
 deformable pin on the grip member interlocking with a hole in the base
 member.
10. A winding device as claimed in claim 7, 8 or 9, wherein the grip member
25 includes apertures which respectively align with and provide access to the
 inner surface of each projection when the grip member is locked with the
 base member to allow for manual rotation of the base member relative to
 the casing member.
11. A winding device as claimed in any one of claims 7 to 10, wherein chamfer
 portions are included on the perimeter of the grip member to assist a user to

grip and rotate the grip member and locked base member.

12. A winding device as claimed in any preceding claim, wherein the base member is generally elliptical or circular in profile.
13. A winding device as claimed in any preceding claim, wherein the winding
5 projections are both generally circular in profile.
14. A winding device as claimed in any preceding claim, further including a cover member able to be secured with said casing member.
15. A winding device as claimed in claim 14, wherein the cover member to
10 assists in retaining the infusion tubing wound around the two winding projections.
16. A winding device as claimed in claim 14 or 15, wherein at least a portion of the cover member is substantially transparent to allow any tubing wound within the winding device to be readily observed.

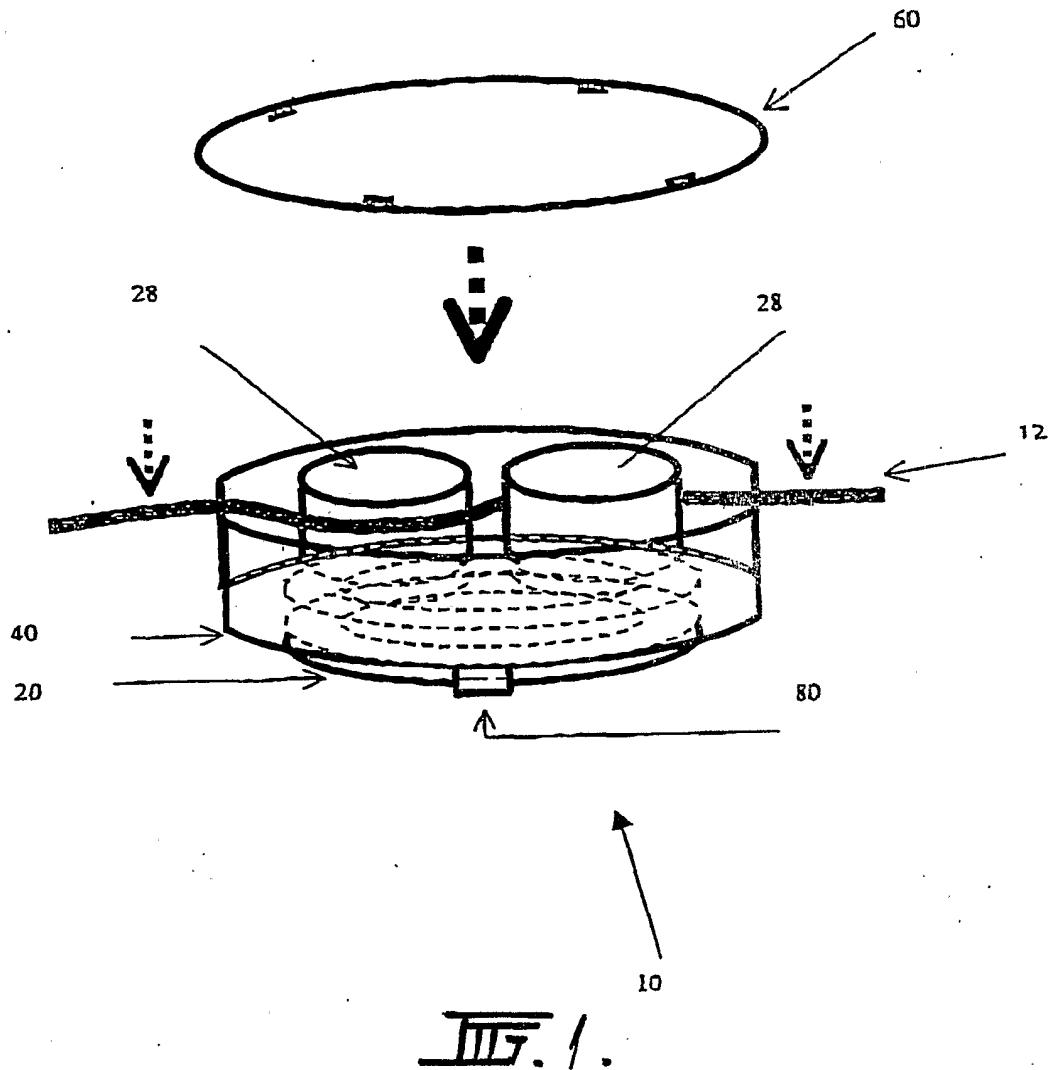

2/20

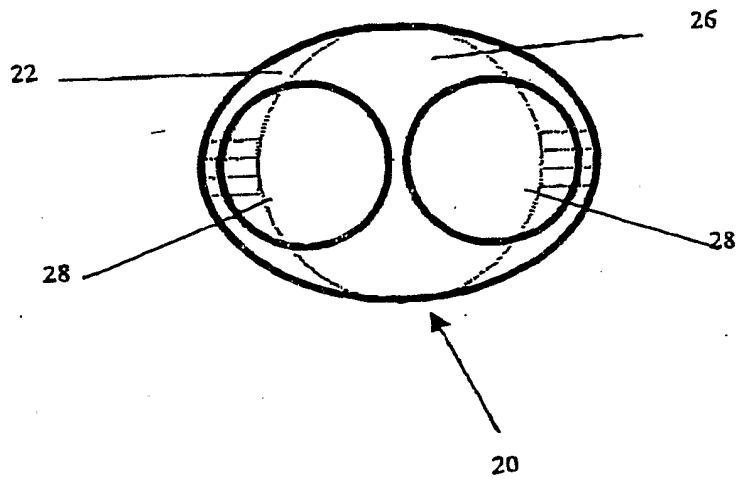

III. 2 .

SUBSTITUTE SHEET (RULE 26)

3/20

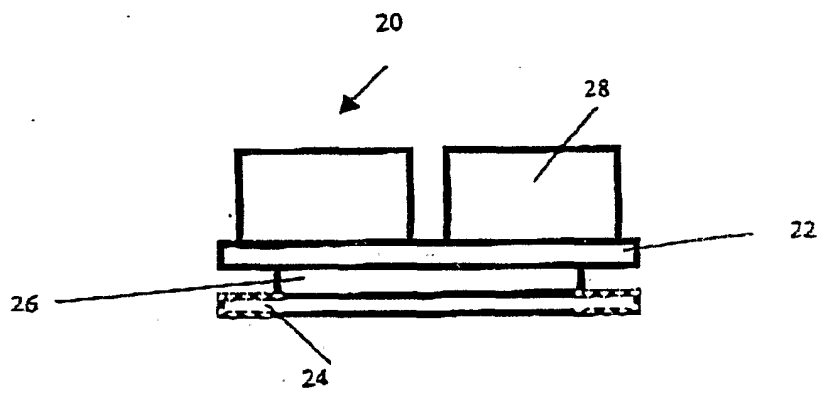

III. 3A.

SUBSTITUTE SHEET (RULE 26)

4/20

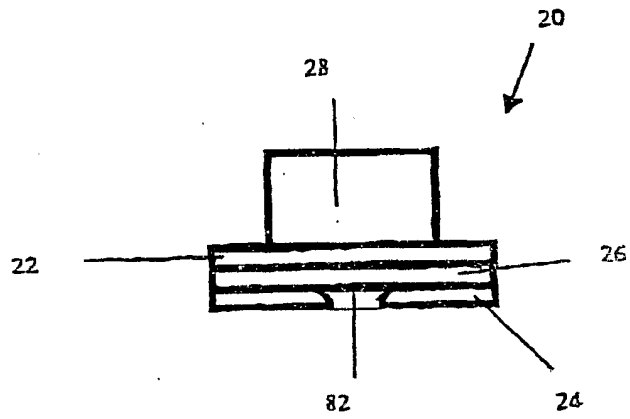

III. 3B.

SUBSTITUTE SHEET (RULE 26)

5/20

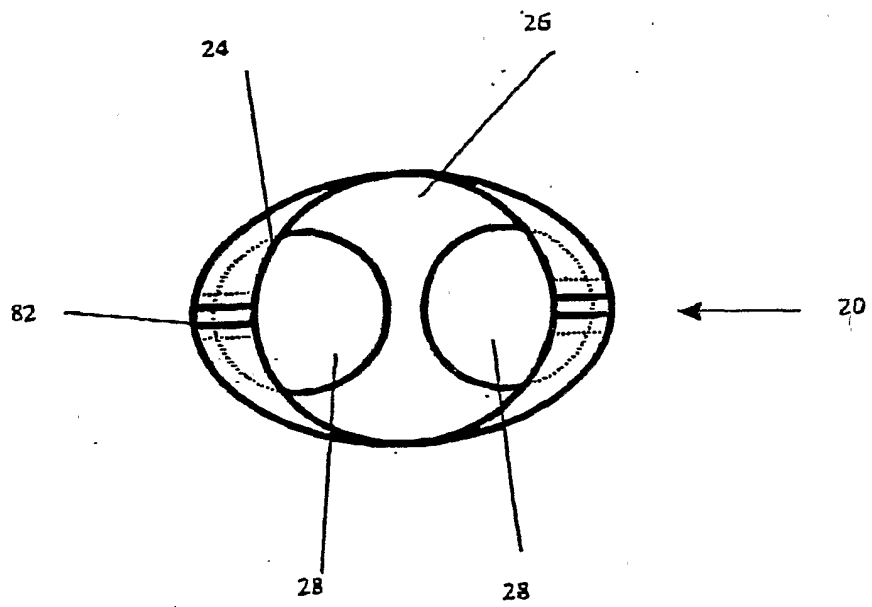
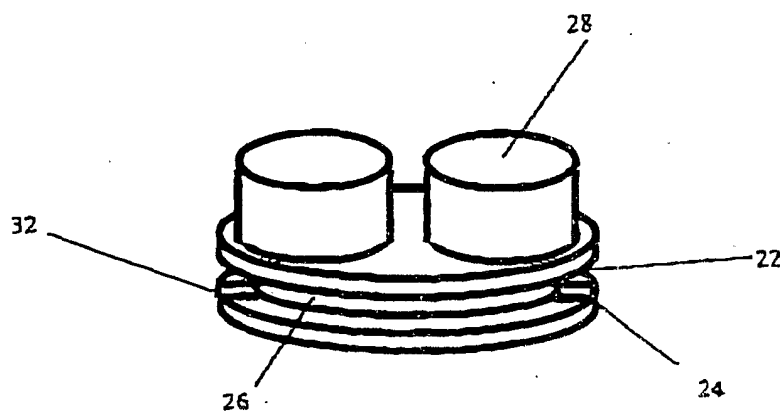

Fig. 4.

SUBSTITUTE SHEET (RULE 26)



III. 5.

SUBSTITUTE SHEET (RULE 26)

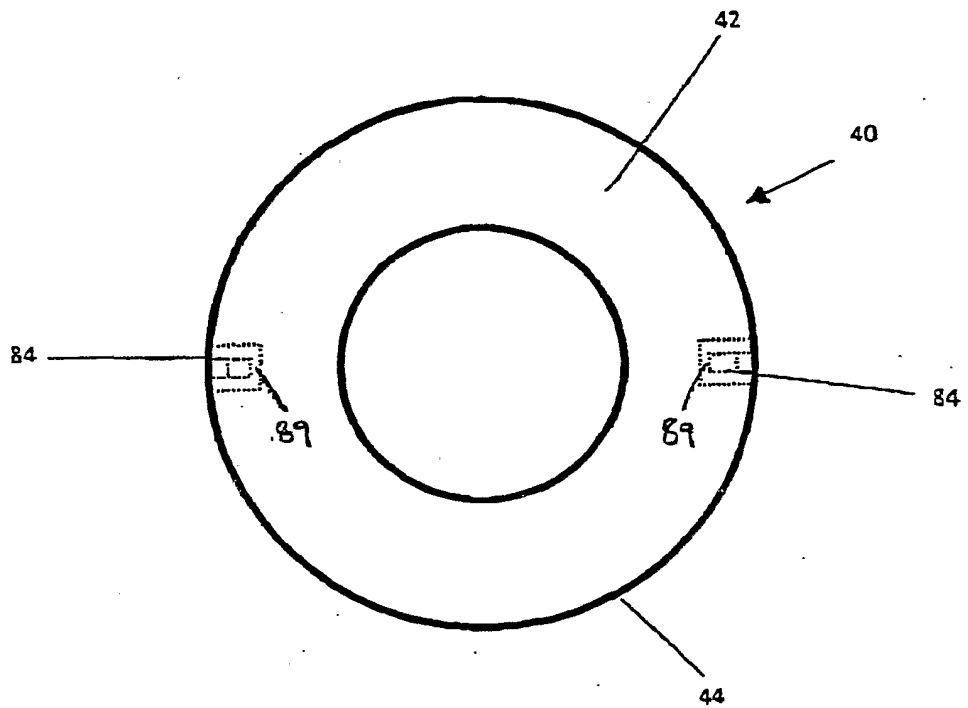

III. 6.

SUBSTITUTE SHEET (RULE 26)

8/20

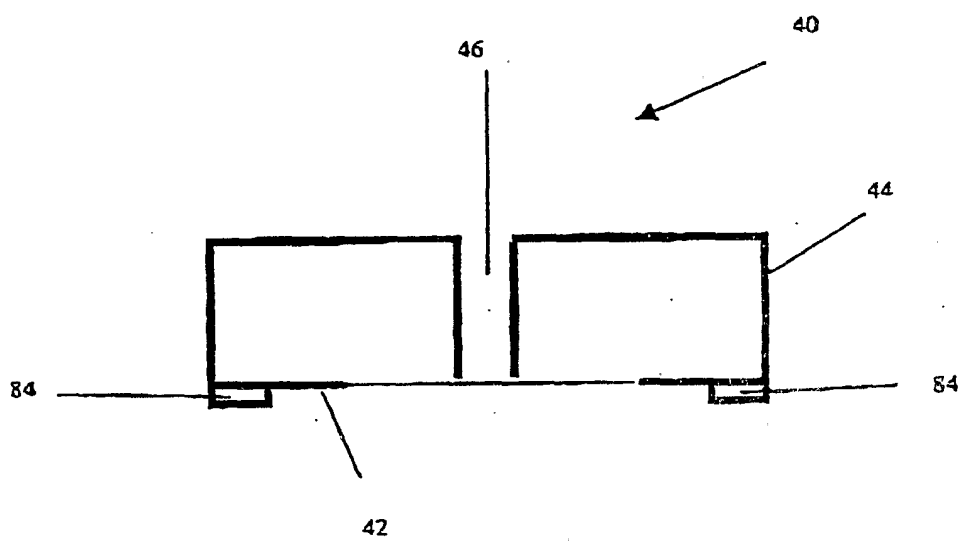

FIG. 7.

9/20

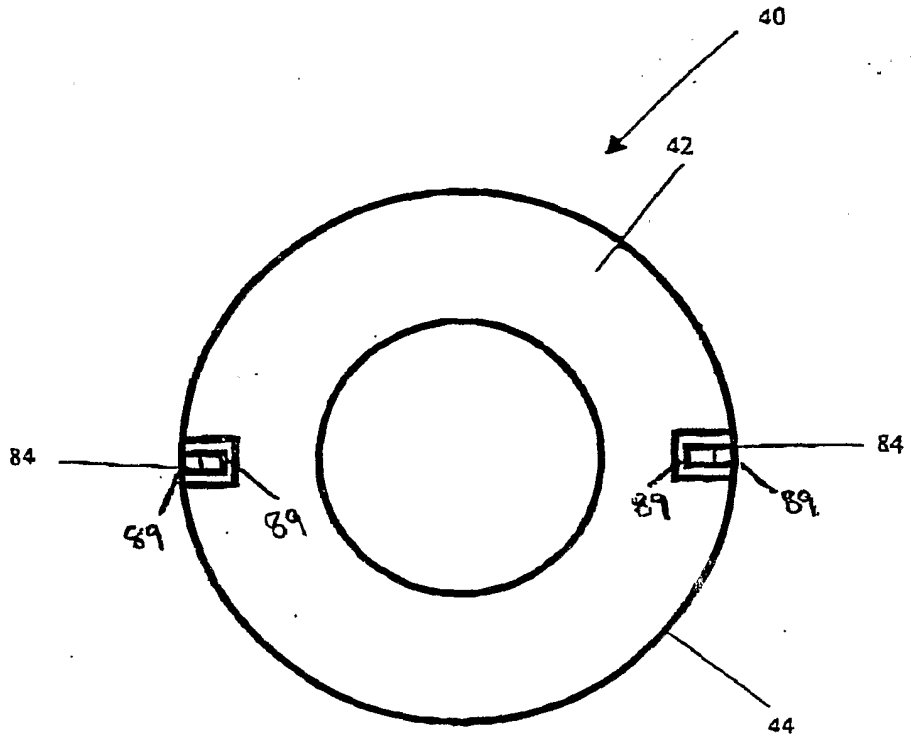

FIG. 8

SUBSTITUTE SHEET (RULE 26)

10/20

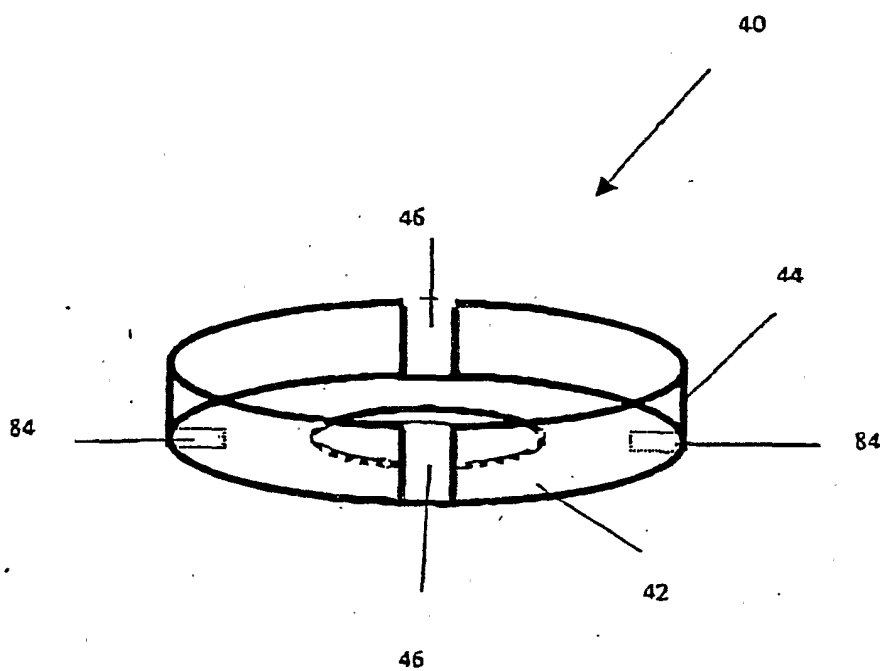

FIG. 9.

SUBSTITUTE SHEET (RULE 26)

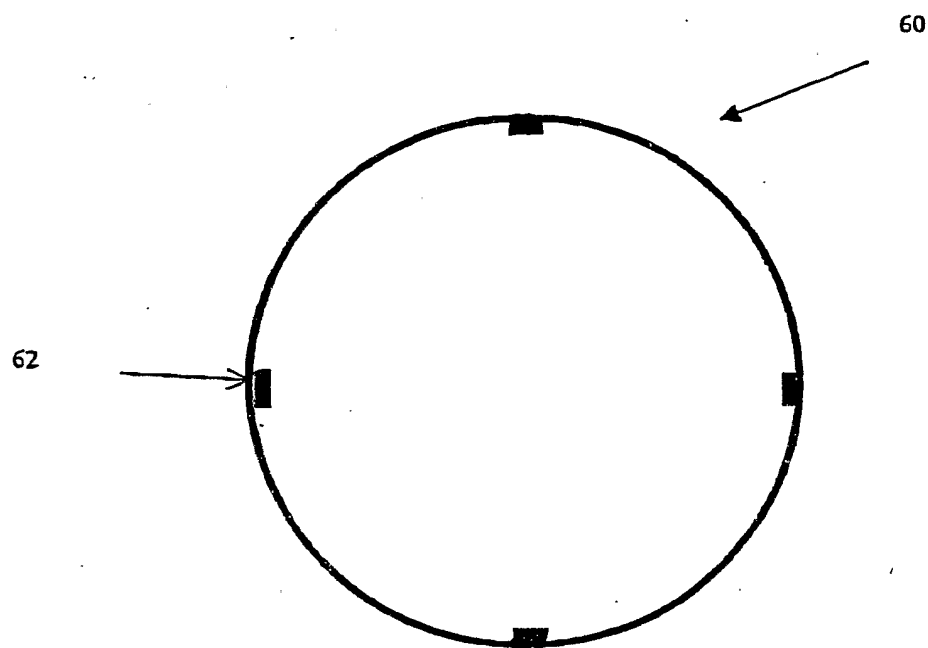

FIG. 10.

12/20

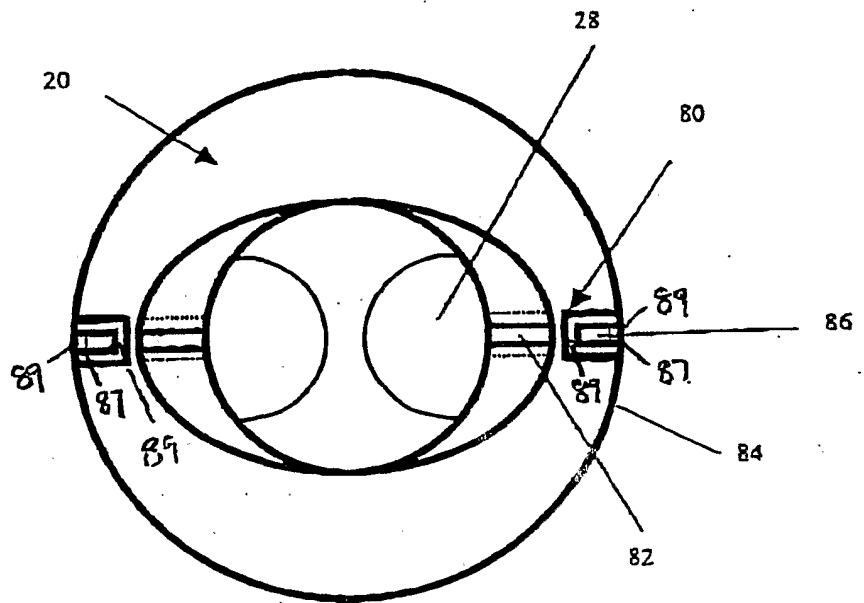

FIG. 11.

SUBSTITUTE SHEET (RULE 26)

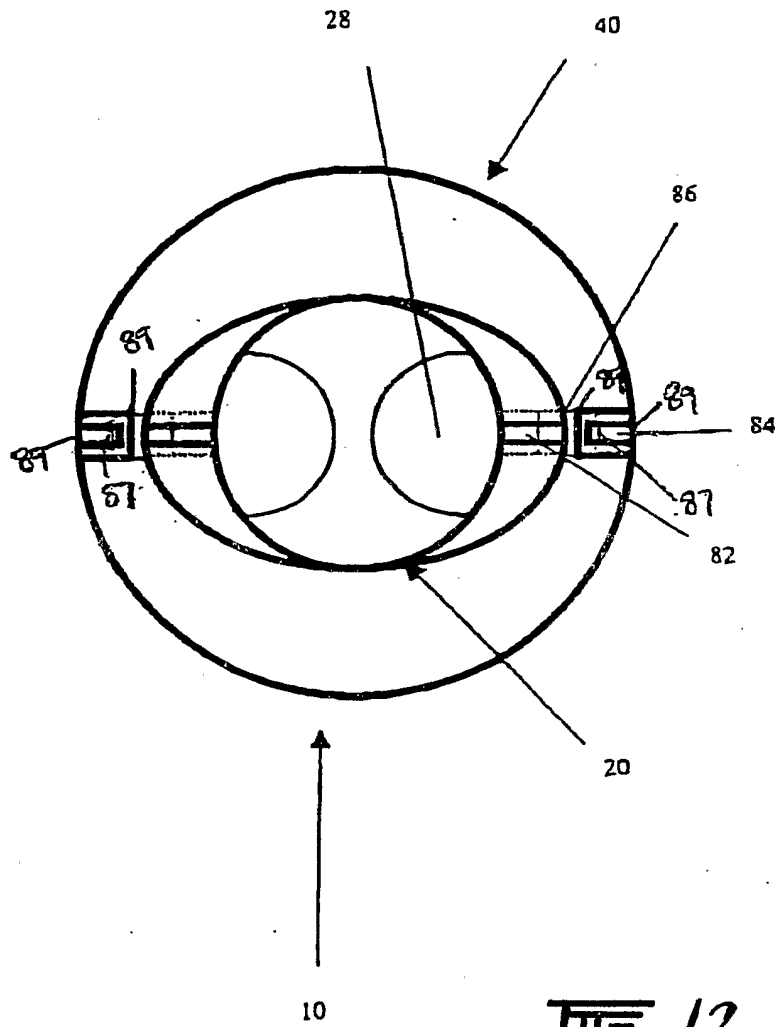
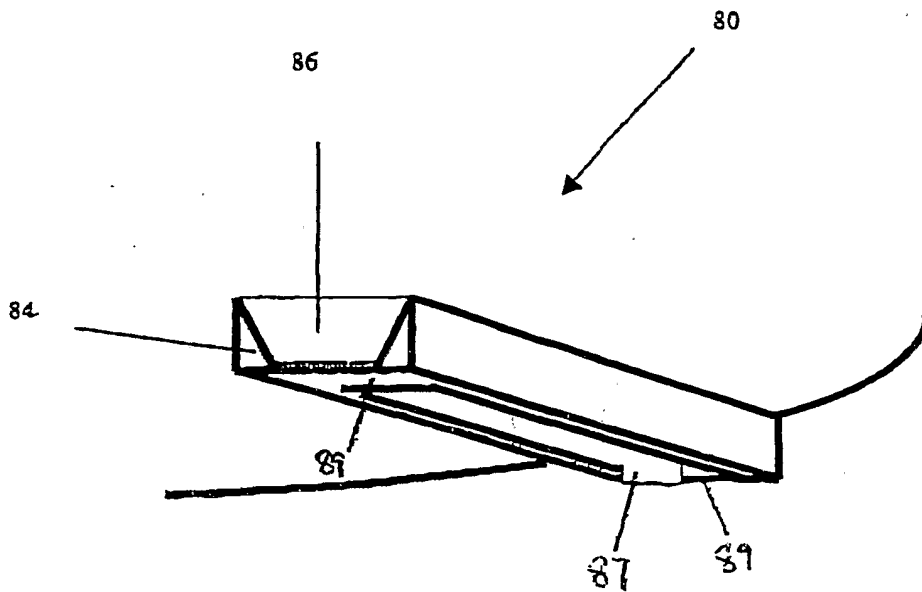

FIG. 12.

14/20



III. 13.

SUBSTITUTE SHEET (RULE 26)

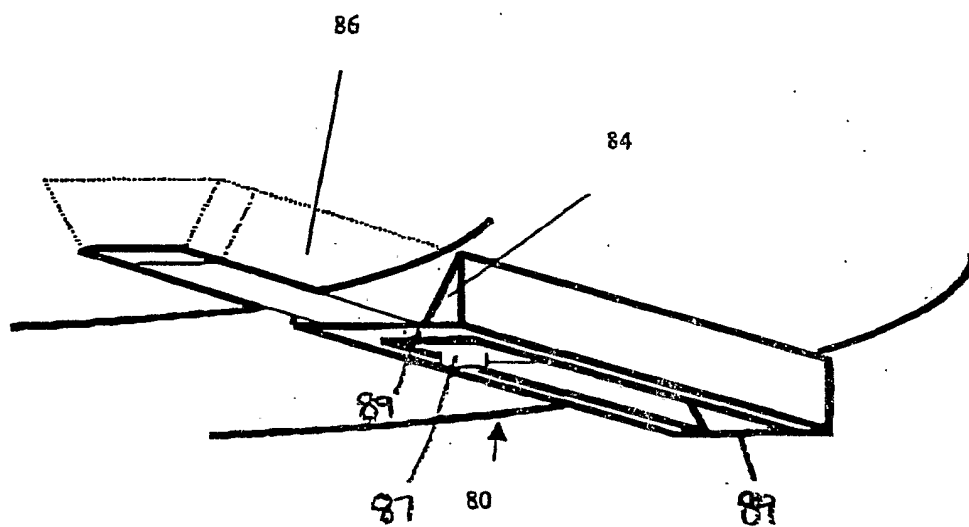

III. 14.

16/20

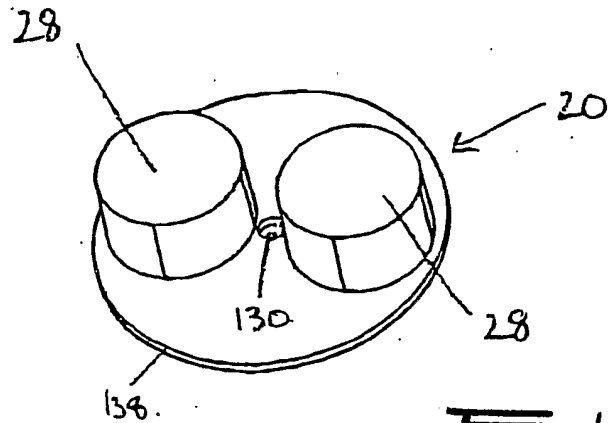

FIG. 15.

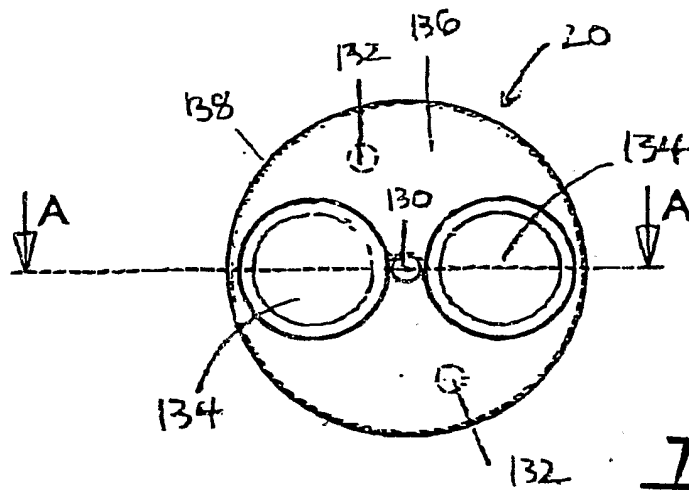

FIG. 16.

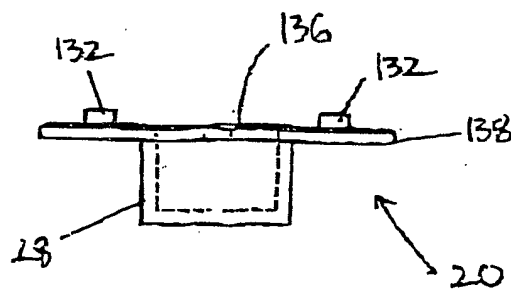

FIG. 17.

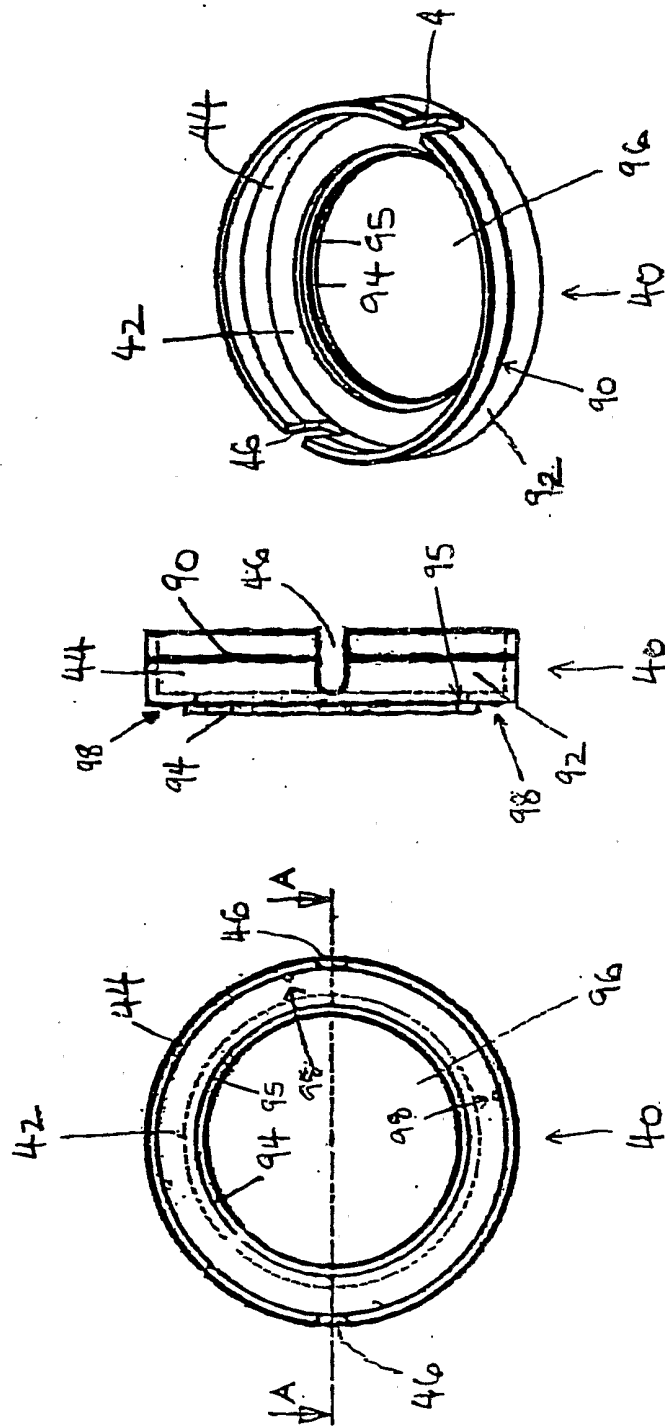
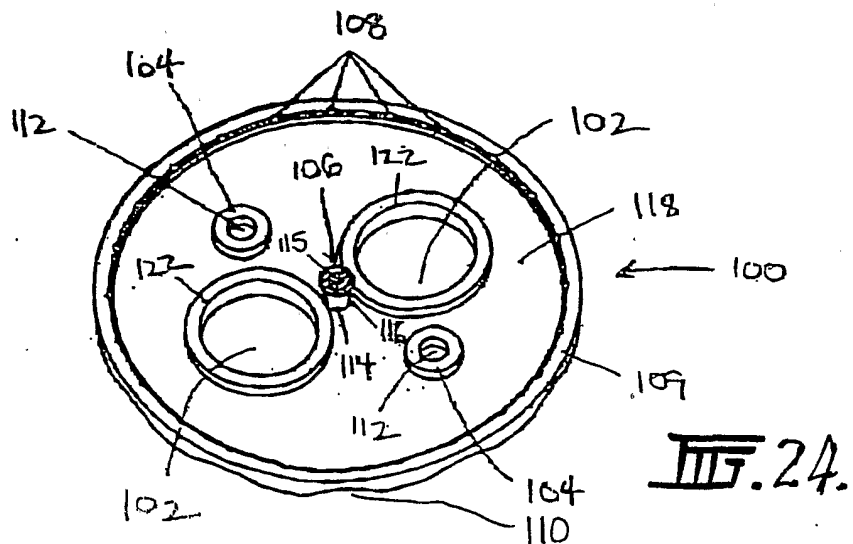
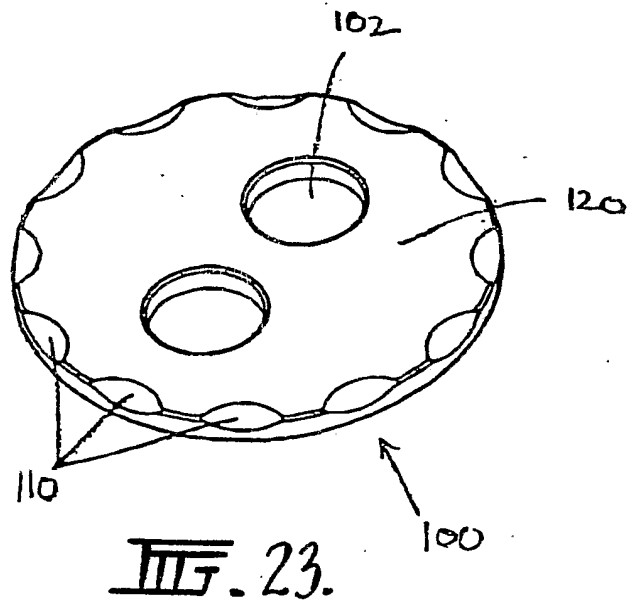
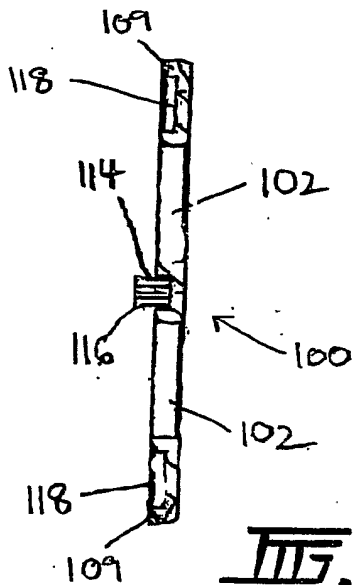
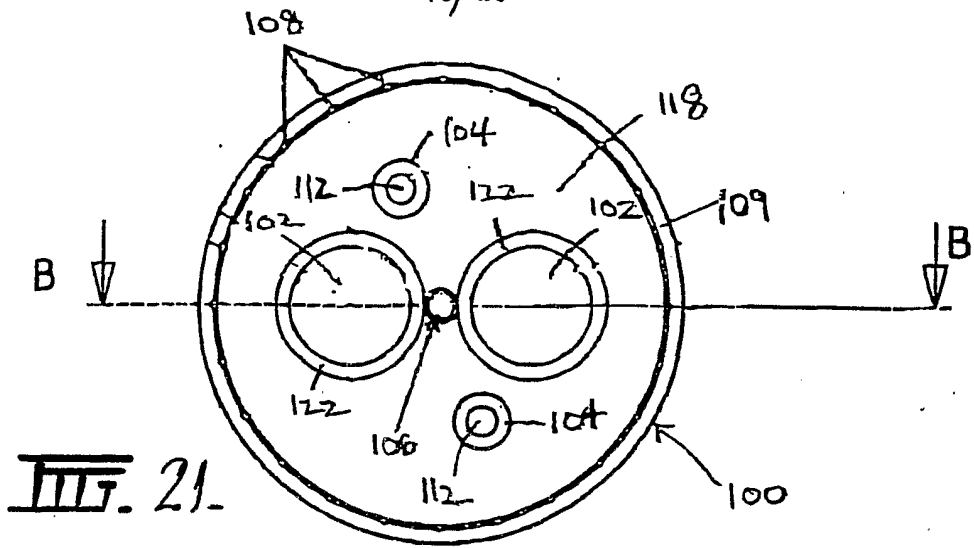

FIG. 18.

FIG. 19.

FIG. 20.

18/20



19/20

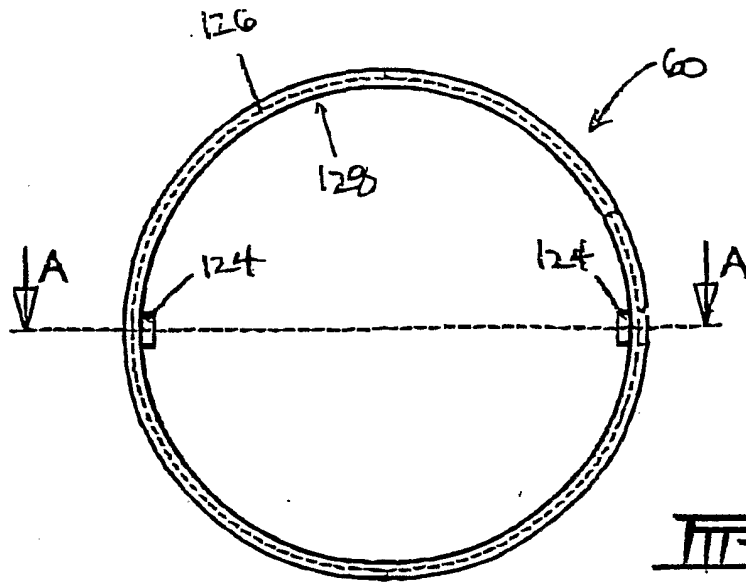

FIG. 25.

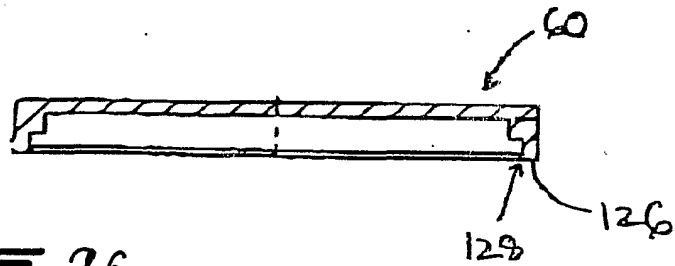

FIG. 26.

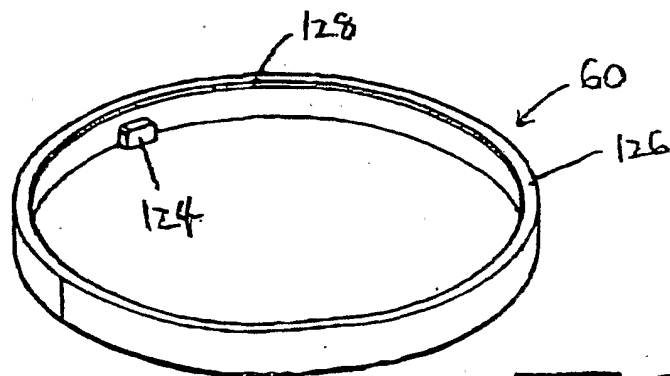
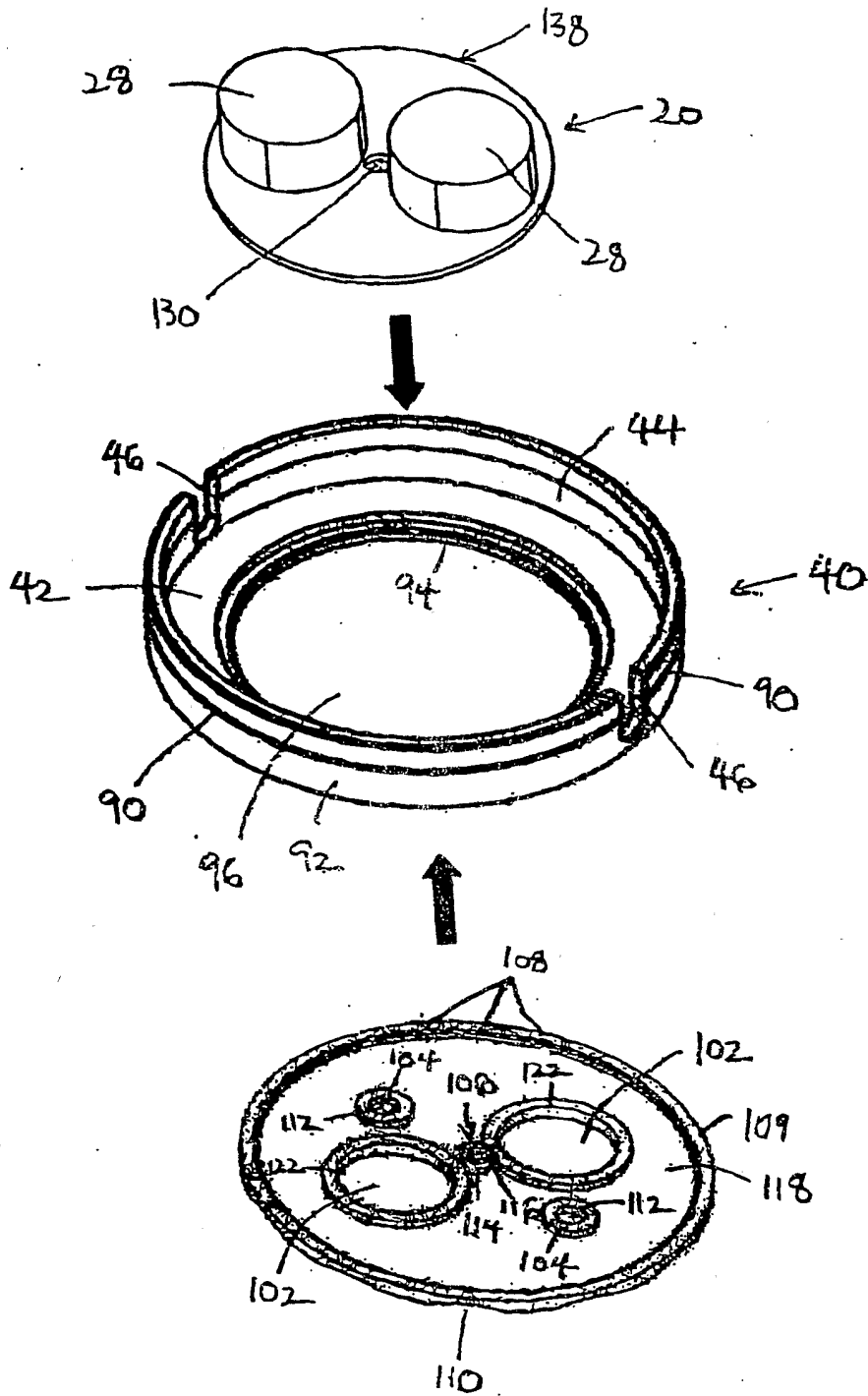

FIG. 27.

20/20



III. 28.

INTERNATIONAL SEARCH REPORT

International application No.

PCT/SG01/00246

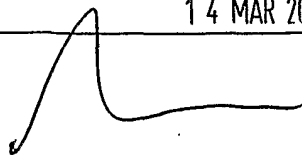
A. CLASSIFICATION OF SUBJECT MATTER		
Int. Cl. ⁷ : B65H 75/34 , 75/36		
According to International Patent Classification (IPC) or to both national classification and IPC		
B. FIELDS SEARCHED		
Minimum documentation searched (classification system followed by classification symbols) B65H 75/34 , 75/36		
Documentation searched other than minimum documentation to the extent that such documents are included in the fields searched AU: B65H 75/34 , 75/36		
Electronic data base consulted during the international search (name of data base and, where practicable, search terms used)		
C. DOCUMENTS CONSIDERED TO BE RELEVANT		
Category*	Citation of document, with indication, where appropriate, of the relevant passages	Relevant to claim No.
A	Derwent Abstract Accession No. 99-225721/19, Class Q36, JP11060077 A (HAYASHI) 2 March 1999 See entire abstract	
A	Derwent Abstract Accession No.2000-501261/45, Class Q36, JP2000177934-A (KUSAMA H) 27 June 2000 See entire abstract	
A	AU 52972/98 A (BURKE) 13 August 1998 See entire specification.	
<input checked="" type="checkbox"/> Further documents are listed in the continuation of Box C <input checked="" type="checkbox"/> See patent family annex		
* Special categories of cited documents:		
"A"	document defining the general state of the art which is not considered to be of particular relevance	"T" later document published after the international filing date or priority date and not in conflict with the application but cited to understand the principle or theory underlying the invention
"E"	earlier application or patent but published on or after the international filing date	"X" document of particular relevance; the claimed invention cannot be considered novel or cannot be considered to involve an inventive step when the document is taken alone
"L"	document which may throw doubts on priority claim(s) or which is cited to establish the publication date of another citation or other special reason (as specified)	"Y" document of particular relevance; the claimed invention cannot be considered to involve an inventive step when the document is combined with one or more other such documents, such combination being obvious to a person skilled in the art
"O"	document referring to an oral disclosure, use, exhibition or other means	"&" document member of the same patent family
"P"	document published prior to the international filing date but later than the priority date claimed	
Date of the actual completion of the international search 4 March 2002	Date of mailing of the international search report 14 MAR 2002	
Name and mailing address of the ISA/AU AUSTRALIAN PATENT OFFICE PO BOX 200, WODEN ACT 2606, AUSTRALIA E-mail address: pct@ipaustalia.gov.au Facsimile No. (02) 6285 3929	Authorized officer  R. WEBER Telephone No : (02) 6283 2546	

INTERNATIONAL SEARCH REPORT

International application No.

PCT/SG01/00246

C (Continuation). DOCUMENTS CONSIDERED TO BE RELEVANT		
Category ^a	Citation of document, with indication, where appropriate, of the relevant passages	Relevant to claim No.
A	DE 2621823 A (SIEMENS AG) 1 December 1977 See entire specification	
A	DE 29902269 A (POLYMAX PRECISION INDUSTRIAL CO.) 13 January 2000 See entire specification	
A	DE 29915767 U (BRUNNER) 25 May 2000 See entire specification	
A	US 4416429 A (JESSAMINE) 22 November 1983 See entire specification	
A	US 5975120 A (NOVOSEL) 2 November 1999 See entire specification	
A	WO 99/41183 A (GIBBS) 19 August 1999 See entire specification	
A	WO 99/10134 A (MULLER) 4 March 1999 See entire specification	

INTERNATIONAL SEARCH REPORT
Information on patent family members

International application No.
PCT/SG01/00246

This Annex lists the known "A" publication level patent family members relating to the patent documents cited in the above-mentioned international search report. The Australian Patent Office is in no way liable for these particulars which are merely given for the purpose of information.

Patent Document Cited in Search Report		Patent Family Member					
AU	52972/98	CA	2228713	US	5992787		
DE	29902269	FR	2782853				
WO	9941183	AU	24361/99				
WO	9910134	AU	93406/98	BG	104224	BR	9812025
		EE	200000101	EP	1007290	HU	200003348
		NO	20000945	PL	338801	SK	200000244

END OF ANNEX