

(19) AUSTRALIAN PATENT OFFICE

(54) Title
Latch mechanism for pivoting handle assembly of a power tool

(51)⁶ International Patent Classification(s)
A01G 3/053 (2006.01) 3/36
H01H 3/36 (2006.01) 20060101ALI2005100
H01H 9/06 (2006.01) ^{8BMEP} **H01H**
A01G 3/053 9/06
20060101AFI2005100 20060101ALN200510
^{8BMEP} **H01H** ^{08BMEP}

(21) Application No: 2004203405 (22) Application Date: 2004 .07 .26

(30) Priority Data

(31) Number	(32) Date	(33) Country
0410914.6	2004 .05 .17	GB
0318751.5	2003 .08 .09	GB
0318150.0	2003 .08 .04	GB

(43) Publication Date : 2005 .02 .24

(43) Publication Journal Date : 2005 .02 .24

(71) Applicant(s)
Black & Decker, Inc.

(72) Inventor(s)
Stones, Kevin

(74) Agent/Attorney
Davies Collison Cave, 1 Nicholson Street, Melbourne, VIC, 3000

(56) Related Art
US 6108867 A
US 2003/0088987 A1
US 5778649 A

ABSTRACT

A latch mechanism for a power tool is disclosed, in which the power tool has a housing (3), a motor provided in the housing, an output shaft adapted to be caused by said motor to actuate a working member, and a handle assembly (2) adapted to pivot relative to the housing between a plurality of positions. The latch mechanism
5 comprises first detent means having at least one first detent member (81) adapted to move outwardly from the housing (3) to engage said handle assembly (2) to releasably retain the handle in at least one first said position; second detent means having at least one second detent member (82) adapted to pivot relative to the housing (3) to engage said handle assembly (2) to releasably retain the handle
10 assembly in at least one second said position; and biasing means (86) for urging at least one said first detent member (81) and at least one said second detent member (82) towards said handle assembly; wherein said first detent means is connected to said second detent means such that movement relative to the housing of at least one said first or second detent member not engaging the handle assembly releases said
15 handle assembly from the corresponding said first or second detent means.

[Figure 16b]

P-AU-GD1080BB

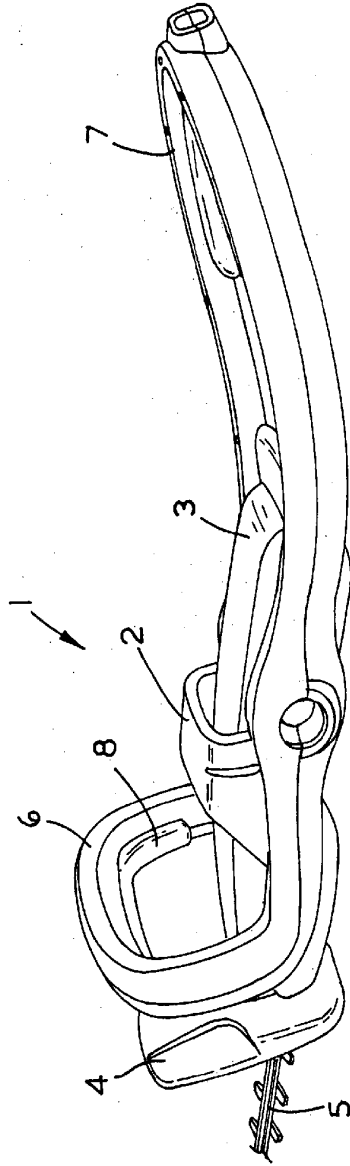

FIG. 2

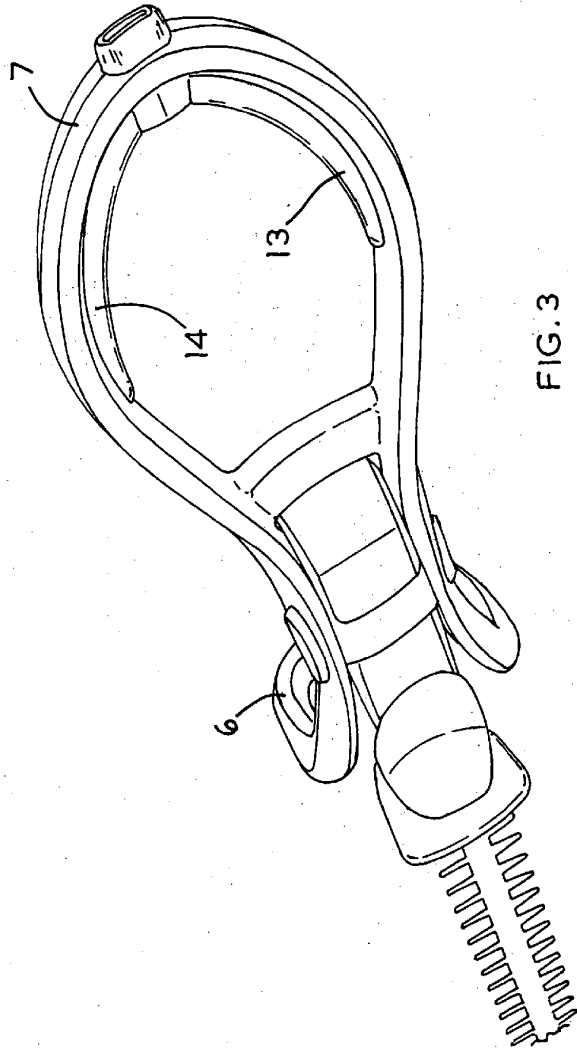

FIG. 3

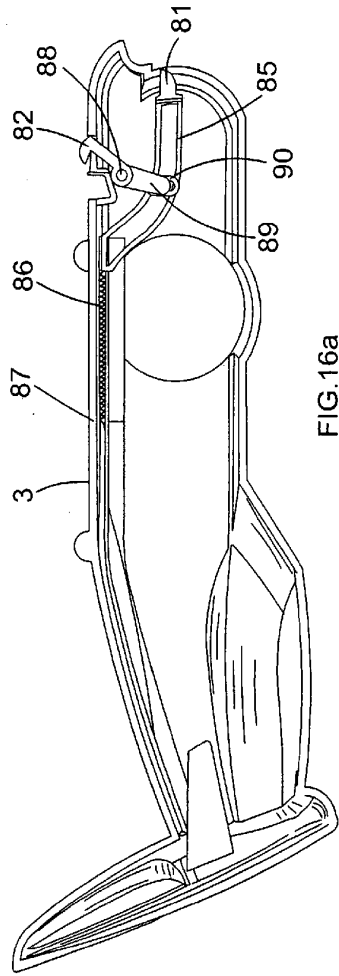

FIG. 16a

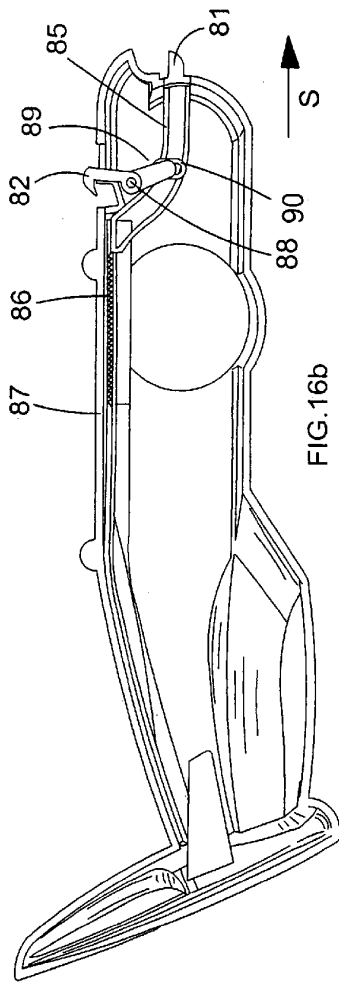

FIG. 16b

AUSTRALIA
PATENTS ACT 1990
COMPLETE SPECIFICATION

NAME OF APPLICANT(S)::

Black & Decker, Inc.

ADDRESS FOR SERVICE:

DAVIES COLLISON CAVE
Patent Attorneys
1 Nicholson Street, Melbourne, 3000, Australia

INVENTION TITLE:

Latch mechanism for pivoting handle assembly of a power tool

The following statement is a full description of this invention, including the best method of performing it known to me/us:-

5102

The present invention relates to a latch mechanism for a pivoting handle assembly of a power tool, and to a power tool incorporating such a mechanism. The invention relates particularly, but not exclusively, to a latch mechanism for the pivotable handle assembly of a hedge trimmer, and to a hedge trimmer incorporating such a mechanism.

Hedge trimmers are power tools for general garden use with an axially reciprocating blade comprising a plurality of teeth disposed adjacent a stationary blade, the teeth of the stationary blade providing a reaction force for the teeth of the reciprocating blade.

Most hedge trimmers are provided with two handles for the user to grip. This is generally for two reasons. Firstly, a hedge trimmer is easier to manipulate when held with both hands than when held with one hand. This provides the user with greater control over the hedge trimmer and therefore facilitates more accurate cutting. Secondly, a two handed grip is a safety feature. It is significantly easier to lose control of a hedge trimmer when holding it with one hand, and therefore a two handed grip allows much safer use of the hedge trimmer.

When hedge trimmers are used to cut high up relative to the user's body, for example to cut the horizontal upper surface of a hedge, most hedge trimmers have to be held with both hands above head height and with the hedge trimmer upside down. This can be tiring for the user and generally makes the user feel unstable as the centre of mass of the user and hedge trimmer is moved further up the user's body. This situation can be particularly dangerous when a user has mounted a set of step ladders, and is therefore even more unstable than he would be were he standing on the ground.

For this reason, the handle assembly of the hedge trimmer may be pivotable relative to the hedge trimmer housing in order to enable the user easier access to higher and lower cutting positions.

Power tools are known which comprise a body portion pivotable relative to a handle assembly, for example in EP 0834248. However, such power tools suffer from the drawback that mechanisms consisting of many components are necessary to enable the tool to be locked in more than one position.

5

Preferred embodiments of the present invention seek to overcome the above disadvantage of the prior art.

According to an aspect of the present invention, there is provided a latch mechanism for a power tool having a housing, a motor provided in the housing, an output shaft adapted to be caused by said motor to actuate a working member, and a handle assembly adapted to pivot relative to the housing between a plurality of positions, the latch mechanism comprising:-

15 first detent means having at least one first detent member adapted to move outwardly from the housing to engage said handle assembly to releasably retain the handle in at least one first said position;

second detent means having at least one second detent member adapted to pivot relative to the housing to engage said handle assembly to releasably retain the handle assembly in at least one second said position; and

20 biasing means for urging at least one said first detent member and at least one said second detent member towards said handle assembly;

wherein said first detent means is connected to said second detent means such that movement relative to the housing of at least one said first or second detent member not engaging the handle assembly releases said handle assembly from the corresponding said first or second detent means.

By providing a latch mechanism which operates in at least two positions, wherein a user can deactivate the mechanism by pushing a detent member against the action of a biasing means to release the handle assembly from the detent means engaging it, this provides the advantage of enabling the mechanism to be constructed from fewer components than prior art mechanisms, thus minimising production costs.

30

At least one said detent member may be adapted to be displaced against the action of said biasing means to enable the housing to be pivoted into a said position, and to prevent said housing being pivoted out of said position.

5 This provides the advantage that the detent members do not have to be initially retracted into the housing before the housing and handle assembly can be located in position relative to each other, thus facilitating operation of the power tool.

The latch mechanism may further comprise at least one abutment surface
10 provided on said handle assembly, wherein at least one said abutment surface prevents further rotation of said housing when in at least one said position.

Said handle assembly may comprise integrally formed front and rear handles.

15 At least one said second detent member may comprise a hook.

The biasing means comprise at least one helical spring.

At least one said helical spring may be disposed adjacent an inner surface of
20 said housing.

This provides the advantage of enabling efficient use of space in the housing, which in turn enables the tool to be made of compact construction.

25 At least one said position may be a working position.

At least one said position may be a storage position.

30 According to another aspect of the present invention, there is provided a power tool having a housing, a motor provided in the housing, an output shaft adapted to be caused by said motor to actuate a working member, a handle assembly adapted to pivot relative to the housing between a plurality of positions, and a latch mechanism as defined above.

P-AU-GD1080BB

The power tool may be a hedge trimmer.

Preferred embodiments of the present invention will now be described, by way of example only and not in any limitative sense, with reference to the accompanying drawings in which:-

Figure 1 is a side view of a prior art truncated conical bevel gear assembly for use in a hedge trimmer;

Figure 2 is a perspective view from a first side of a hedge trimmer of a first embodiment of the present invention;

Figure 3 is a perspective view from below of the hedge trimmer of Figure 2;

Figure 4 is a rear perspective view of the hedge trimmer of Figure 2;

Figure 5 is a side perspective view of the hedge trimmer of Figure 2, from the opposite side as that shown in Figure 2;

Figure 6 is a perspective view from above of a hedge trimmer of a second embodiment of the present invention;

Figure 7 is a side perspective view of the handle assembly and body of the hedge trimmer of Figure 6;

Figure 8 is a side and rear perspective view of the handle assembly and body rear of the hedge trimmer with the body portion tilted at an angle to the handle assembly;

Figure 9 is a further side perspective view of the hedge trimmer of Figure 8;

Figure 10a is a cross sectional side view of the gear conversion mechanism of the hedge trimmer;

Figure 10b is a top view of the gear conversion mechanism of Figure 10a;

Figure 11 is a side cross sectional view of the housing of a hedge trimmer incorporating the gear conversion mechanism of Figures 10a and 10b;

Figure 12 is a schematic view of a switching mechanism in the trimmer embodying the invention in the open position;

Figure 13 is a schematic view of the switching mechanism of Figure 12 in the closed position;

Figure 14a is a side view of the switching mechanism and relay in the trimmer in the open position where the handle assembly is in the horizontal orientation relative to the housing;

2004203405 02 Jun 2010

5

Figure 14b is a side view of the switching mechanism of Figure 14A in the partially closed position;

Figure 14c is a side view of the switching mechanism and relay of Figure 14A in which the relay is closed;

5 Figure 15a is a side view of the switching mechanism of Figure 14A in which the handle assembly is rotated through 90° relative to the housing and the switch and relay are in the open position;

Figure 15b is a side view of the switching mechanism of Figure 15A in the partially closed position;

10 Figure 15c is a side view of the switching mechanism of Figure 15A in which the relay is closed;

Figure 16a is a cross sectional side view of the hedge trimmer housing with the latch mechanism in the open position;

15 Figure 16b is a cross sectional side view of the hedge trimmer housing of Figure 17a with the latch mechanism in the closed position;

Figure 17a is a side view of the hedge trimmer housing, with the latch mechanism in the open position; and

20 Figure 17b is a side view of the hedge trimmer housing of Figure 16a, with the latch mechanism in the closed position and engaging the hedge trimmer handle assembly.

Referring to Figure 2, a hedge trimmer (1) comprises a handle assembly (2) formed from durable plastics material pivotably connected to a housing (3). A guard (4) is formed integrally with the housing (3) and an electric motor (not shown) is disposed axially within the housing (3) such that the axis of rotation of an output shaft (not shown) of the motor is generally parallel to the direction of reciprocating motion of a blade assembly (5).

30 The blade assembly (5) extends forwardly of the housing (3). The electric motor (not shown) is connected to the blade assembly via a drive conversion mechanism, the operation of which will be described in further detail below. The blade assembly (5) comprises a stationary blade disposed adjacent to a blade adapted to execute reciprocating movement along a longitudinal axis of the stationary blade. In this way, the stationary blade provides a reaction force for the

2004203405 02 Jun 2010

reciprocating blade to grip against and cut. The operation of this type of blade assembly is well known in the art and will not be described in any further detail herein.

5 The handle assembly (2) comprises a forward handle (6) and a rear handle (7). Both forward and rear handles (6), (7) are formed integrally from moulded durable plastics and enable a user to hold the hedge trimmer in a variety of ways. As is well known in the art, it is desirable for certain power tools such as chainsaws, hedge trimmers and circular saws to have two handles for the user to grip, one with either
10 hand. A two-handle assembly has two advantages. Firstly, when the tool is gripped in both hands it is more stable in the user's hands and therefore easier to control, which enables more accurate and precise cutting. Secondly, a two-handed grip on the hedge trimmer is a lot safer than a single handed grip. It is a lot easier for a user to lose control of a hedge trimmer when gripping it with only one hand.

15 The hedge trimmer is provided with a dual switching mechanism. In order to activate the hedge trimmer, the user must simultaneously depress a forward switch (8) and either one of rear switches (13), (14), as shown in Figure 3. As a result, it is impossible for the user to activate the hedge trimmer without first gripping it with both
20 hands.

It is desirable when operating a hedge trimmer with the blade in the vertical plane for the user to be able to grip the hedge trimmer without twisting either wrist at an angle relative to the other. Referring to Figure 4, the present embodiment provides a
25 handle assembly which allows a left-handed user and a right-handed user to operate the hedge trimmer in any orientation with the wrists of each arm aligned, i.e. with the wrists arranged along parallel axes. For example, the right-handed user would grip forward handle (6) with his left hand such that the fingers of his left hand pass around the front of forward handle (6) and grip switch (8) with the fingertips of his left hand.
30 The right-handed user would place his right hand around rear handle (7) such that the fingertips of his right hand grip switch (13). It can be seen that in this orientation the right-handed user holds the hedge trimmer such that the insides of his wrists are facing each other and his wrists are aligned in planes generally parallel to the plane of the blade. The same can be said of the left-handed user. However the left-handed

user would grip forward handle (6) with his right hand and rear handle (7) with his left hand such that the fingertips of his left hand are in a position to depress switch (14).

2004203405 02 Jun 2010

This feature offers several advantages over the prior art. Firstly, holding the hedge trimmer without a twist in the user's arm is more comfortable, and affords the user more control over the hedge trimmer blade. Secondly, prior art hedge trimmers must be held with a twist in the user's arm. Over prolonged periods of use, the user's arms may tire, and apply an unwanted torque to the hedge trimmer as the muscles of the user's forearms attempt to orientate themselves into a more comfortable position. This makes it more difficult to accurately cut with the hedge trimmer.

Referring to Figure 5, line A-A represents the plane of blade assembly (5). The plane of rear handle (7) is at an angle to line A-A such that the rear part of rear handle (7) is raised substantially away from the plane of blade (5). As a result of this, the knuckles of the hand of the user that is gripping rear handle (7) are raised away from the surface of the hedge being cut. This provides the advantage that the user's knuckles avoid any grazing or cutting resulting from contact with the hedge, or with the ground when carrying out low cutting.

Referring to Figures 6 and 7, in which parts common to the embodiment of Figures 2 to 5 are denoted by like reference numerals but increased by 100, a second embodiment of the handle assembly (102) is shown. It can be seen that front handle (106) is swept back at a greater angle relative to the plane of the blade compared with the angle of front handle (6) relative to the plane of blade (5) as shown in Figure 5. This feature makes the hedge trimmer more comfortable for the user to operate provided that the centre of mass of the hedge trimmer lies in the region between front handle (106) and rear handle (107) which will usually be the case, since the heaviest parts of the hedge trimmer are generally the blade and the motor housing. The user does not have to stretch his forward arm as far relative to the rear handle as he would do when using the handle assembly shown in Figure 5.

It is therefore desirable to have the rear handle located as far away from the centre of mass as is possible. Since the two heaviest components of a hedge

trimmer are generally the electric motor disposed in the housing and the forward blade assembly, the centre of mass of the hedge trimmer generally lies between the motor and the blade.

- 5 In order to make the hedge trimmer easier to manipulate, it is desirable to locate the rear handle (7), (107) as far away from the centre of mass as possible. This is because the further away the rear handle is from the centre of mass, the less force is needed to be applied to the rear handle to apply the same torque to the hedge trimmer. One way of achieving this is to make the rear handle as large as possible without increasing the weight of the rear handle, and for this reason the rear handle (7), (107) of the hedge trimmer is formed into the curved bar loop shape with a space enclosed as is best shown in Figure 2 or in Figure 6.

- 15 The handle assembly (7) of the present invention enables the user to operate the hedge trimmer for cutting a horizontal surface such that the wrists of the user's arms are oriented generally parallel to one another. Also, as described above, when the blade is required to be operated in the vertical plane, the user can operate the hedge trimmer with his wrists arranged in generally parallel vertical planes.

- 20 A problem can arise with prior art hedge trimmers when a horizontal surface to be cut is high up relative to the user such as the horizontal upper surface of a tall hedge, as the user may have to stretch and hold the hedge trimmer above his head. This is undesirable for the user especially when the user is on stepladders or other apparatus to raise the user from the ground. When the user is holding the hedge trimmer high up relative to his body or even holding the hedge trimmer above his head in order to cut a horizontal surface, the user is less stable than he would be were he operating the hedge trimmer further down relative to his body. Furthermore, although hedge trimmers can generally be operated upside down, it has been found that consumers are generally very reluctant to operate hedge trimmers upside down whilst held above the head.

25 Referring to Figures 8 and 9, the hedge trimmer is shown without the forwardly projecting blade where the body housing (3) has been pivoted relative to the handle assembly (2). In this orientation, the hedge trimmer is operated in exactly the same

way as before, with the user gripping both forward and rear handles and depressing forward and rear switches respectively. This feature makes it easier for the user to view along the plane of the blade when cutting the top of a tall hedge, and more comfortable for horizontal cutting in a position high up relative to the user's body.

5 This is because instead of the user having to hold the handles horizontally at eye level as with prior art hedge trimmers, the user can now hold the handle assembly in front of his body whilst looking along the plane of the blade.

Referring to Figures 16a and 16b, the operation of the latch mechanism for
10 holding the hedge trimmer in either of the orientations described above will now be described.

A first retaining member (81) is mounted at a first end of a bracket (85), and the other end of bracket (85) is mounted on a compression spring (86). Compression
15 spring (86) is fixed to the body of the hedge trimmer housing at (87). A second retaining member (82) is able to pivot about a pin (88), pin (88) being fixed relative to the housing (3). Second retaining member (82) is also rigidly fixed to a first end of a lever (89), the second end of lever (89) being slidable in a second bracket (90), second bracket (90) being formed in first bracket (85).

20 When the first bracket (85) is moved in the direction of arrow S from the configuration shown in Figure 16a to the configuration of Figure 16b as a result of compression spring (86) extending, it can be seen that firstly the first retaining member (81) is pushed out of the back of the housing (3). Secondly, as a result of
25 lever (89) sliding upwardly in second bracket (90), the second retaining member (82) is pivoted about pin (88) and out of housing (3).

In the configuration of Figure 16b, either the first or second retaining means (81, 82) will engage with a corresponding portion of the handle assembly (not
30 shown), and a user would release the mechanism simply by pushing the retaining member which is not in engagement with the handle assembly back into the housing, as this action would also result in retracting the other retaining member from engagement with the handle assembly.

2004203405 02 Jun 2010

Referring to Figures 17a and 17b, the hedge trimmer housing (3) engages the hedge trimmer handle assembly at a cylindrical pivot (80) such that the housing (3) can rotate about pivot portion (80). The hedge trimmer can be operated in two separate orientations, the in-line orientation as shown in Figure 2, or the orientation
5 shown in Figures 8 and 9 where the hedge trimmer housing (3) is rotated through 90° relative to the hedge trimmer handle assembly (2).

In order to retain the hedge trimmer housing (3) in position relative to the handle assembly (not shown), the housing (3) is provided with a first retaining member (81) and a second retaining member (82). Both first and second retaining members (81, 82) are retractable relative to the housing (3), and are shown in their respective retracted positions in Figure 17a. The rear end of housing (3) has an integrally formed abutment surface (83) shaped to receive an engaging portion (84)
10 of handle assembly (2). It can be seen that the engaging portion (84) of the handle assembly is received between abutment surface (83) of the housing (3) and the first retaining member (81) such that the engaging portion (84) can not move in either the upwards or downwards direction relative to housing (3). The first retaining member (81) is so shaped that the engaging portion (84) can slide into engagement with abutment surface (83) by displacing retaining member (81), but cannot move out of
15 engagement with abutment surface (83) until retaining member (81) is retracted into the housing (3).

When the hedge trimmer is used in the orientation shown in Figures 8 and 9, second retaining member (82) grips a second engaging portion (not shown) of the handle assembly, and in this orientation even though first retaining member (81) is
25 deployed, it is not in use. In order to release the latch mechanism, either first or second retaining members (81, 82) can be depressed by the user, depending on which one is not in engagement with the handle assembly, which simultaneously moves both first and second retaining members (81, 82) into the housing.

30 Referring to Figures 12 and 13, the dual switching mechanism will now be described.

A bowden cable, such as that used to operate the brakes on a pedal bicycle, consists of an inner cable (40) surrounded by an outer sheath (41). The inner cable (40) passes through the outer cable (41) and is slidable relative thereto. An electrical contact shown generally by (42) comprises a first metallic pad (43) mounted on an arm (44), the arm being pivotable about point (45) and a second metallic pad (46) mounted on a second arm (47), the second arm being pivotable about point 48 such that metallic pads (43) and (46) can be pivoted towards each other, and into contact.

A first end of inner cable (40) is attached to metallic pad (43) at point (49), and a first end of outer cable (41) is attached to arm (47) at point (50).

A first switch (51) comprises an arm that is pivotable about point (52), the arm being attached to a second end of inner cable (40) at point (53). A second switch (54) is pivotable about point (55) and is attached to the outer cable at point (56).

Referring to Figure 13, first switch (51) and second switch (54) are operated by a user applying pressure and pivoting them away from each other in the direction shown by arrows I and J. As first switch (51) is rigidly attached to the inner cable (40), and second switch (54) is rigidly attached to the outer cable (41), the pivoting motion of the switches in opposite directions draws the inner cable (40) through outer cable (41), whilst at the same time second switch (54) pushes outer cable (41) around inner cable (40). As a result of this, inner cable (40) pulls first metallic pad (43) in the direction of arrow K, and outer cable (41) pushes the second metallic pad (46) in the direction of arrow L such that pads (43), (46) come into contact.

It can be seen then that if only one switch, either (51) or (54), is moved whilst the other switch remains in the open position, the resulting movement of the bowden cable would only consist of independent movement of either the inner (40) or outer cable (41) such that the contact would only be half closed, as only one metallic pad would be moved into a contacting position.

It should also be appreciated that further embodiments of a switching mechanism of this type are possible with more than two switches. For example, a single inner cable (40) can be provided with a plurality of outer sheaths (41), each

outer sheath moving independently of one another which provides the option of adding more switches and/or electrical contacts. It should also be noted that in practice, taking the example of a two switch mechanism, the mechanism will be set up such that closing one switch will have the result of partially closing the contact by
5 more than half the distance required to fully close the contact, and closing the second switch will also have the result of more than half closing the contact. In this way, it is ensured that the contact will actually be closed when both switches are closed.

It should also be appreciated that Figures 12 and 13 are only a schematic
10 representation of the switching mechanism, and in practise the contacts be in the form of something other than pivoting metallic pads, as will be described below.

Referring to Figures 14a to 15c, the operation of the pivoting switching mechanism will now be described.

15 Referring to Figure 14a, a pin (61) is held in a pin housing (62) which is disposed in the hedge trimmer handle assembly (not shown). The pin (61) and pin housing (62) are slidable relative to the hedge trimmer handle assembly (not shown) in the direction of arrow M. Pin (61) projects outwardly from housing (62) and is received in an aperture (68) formed in an arm member (63). Arm member (63) is
20 mounted to the hedge trimmer body housing (not shown) by a pin (64). Arm member (63) is pivotable about pin (64) in the direction of arrow N relative to the hedge trimmer housing (not shown). An electrical relay (65) is disposed in the hedge trimmer housing (not shown) such that when arm (63) is pivoted in the direction of
25 arrow N, a remote end (66) of arm (63) depresses a switch (67) and closes relay (65).

Referring now to Figure 14b, when a first switch (not shown), is depressed by the user, a cable (not shown) causes pin (61) to slide in the direction of arrow M
30 along cam surface (69) provided in aperture (68). It can be seen, however, that the movement of pin (61) is insufficient to cause arm member (63) to pivot about pin (64) and close relay (65). Referring now to Figure 14c, in order to close the relay, the user must depress a second switch (not shown) provided on the handle assembly, which causes pin (61) to slide a further distance in the direction of arrow M along a second

cam surface (70), provided in aperture (68), causing arm member (63) to pivot about point (64) and close the relay (65).

5 It can therefore be seen that in order to close the relay (65), a user must depress both first and second hedge trimmer switches, which in the embodiment of the hedge trimmer shown in Figure 4 for example, would be switch (8) formed on front handle (6) and either one of switches (13), (14) formed on rear handle (7).

10 Referring to Figure 8, the hedge trimmer body housing (3) can be pivoted at 90° relative to the handle assembly (2). Referring now to Figure 15a, the pin housing (62) is rotated through 90° from the position shown in Figure 14a. Pin (61) now abuts third cam surface (71), and as the hedge trimmer housing has remained stationary, arm member (63) remains in the same position.

15 Referring now to Figure 15b, when a user depresses a first switch (not shown), in the same way as shown in Figure 14b except at 90° to figure 14b, pin (61) moves through a first distance in the direction of arrow P from cam surface (71) to cam surface (69). It can be seen however, that pin (61) has not moved sufficiently to pivot arm (63) about pin (64) to close relay (65).

20 Referring now to Figure 15c, in order to close relay (65), the user must depress a second switch (not shown) which further moves pin (61) in the direction of arrow P thus pivoting arm (63) about pin (64) and completing the closure of relay (65).

25 Referring now to Figure 11, an electric motor (14) is disposed axially in housing (3), such that the axis of rotation (15) of the motor output shaft (16) is parallel to the plane of blade (5). It can be seen therefore that in order to drive the blade mechanism, the direction of rotation about axis (15) needs to be converted through 90° into rotation about axis (17).

30 As shown in Figures 10a and 10b, the drive conversion mechanism for converting rotation about a first axis to rotation about a second axis comprises a shaft (30) rotating in the direction of arrow (31). A plurality of axially aligned parallel teeth (32) are formed at the end of shaft (30). Parallel teeth (32)

intermesh with a second plurality of radial teeth (33) formed on the upper surface of a gear plate (34). Gear plate (34) is mounted on a second shaft (35) such that gear plate (34) is free to rotate about an axis Z-Z. As a result of this, the rotation of shaft (30) imparts rotation to gear plate (35) in the direction of arrow (36) due to the reaction between teeth (32) and teeth (33).

This method of converting rotation about a first axis into rotation about a second axis generally perpendicular to said first axis is substantially cheaper to manufacture than prior art methods, as the engineering tolerances between teeth (32) and shaft (30) and teeth (33) on the gear plate (34) can be less than those needed to be achieved with the conical gears of the prior art drive mechanisms.

Referring again to Figure 11, the incorporation of the drive conversion mechanism of Figures 10a and 10b into the hedge trimmer will now be described.

An electric motor drives a rotary output shaft (16) adapted to rotate about axis (15). A plurality of teeth (40) are formed on the edge of shaft (16) and intermesh with a second plurality of teeth (41) formed on a gear (42). Gear (42) is adapted to rotate about axis (18) which is parallel to axis (15), and as gear (42) comprises a larger number of teeth (41) than the number of teeth (40) formed on output shaft (16), the rotational speed of gear (42) is less than that of output shaft (16). Gear (42) is mounted on a shaft (30) which has a further set of teeth (32) formed around the edge of shaft (30). Teeth (32) intermesh with a plurality of radial teeth (33) formed on the upper surface of a gear plate (34). Gear plate (34) is mounted on shaft (35) and adapted to rotate about axis (17) such that the rotation of shaft (30) about axis (18) is converted to rotation about axis (17) generally perpendicular to axis (18).

It can therefore be seen that the teeth on shaft (32) can still drive gear plate (34) despite variations in position between the shaft and the gear plate, provided the teeth on the shaft still engage the teeth on the gear plate. The shaft and gear plate therefore do not need to be as accurately located relative to each other as the bevel gears of the prior art.

It can also be seen that the inline rotation of the motor output shaft (16) is converted into rotation in the plane of blade (5). The blade (5) is connected to gear plate (34) via a drive conversion mechanism for converting rotary motion about axis (17) into linear reciprocating motion perpendicular to axis (17) in a manner which will
5 be familiar to persons skilled in the art, such as a scotch yoke mechanism. Mechanisms of this type are well known in the art and will not be described herein in any further detail.

It will be appreciated by persons skilled in the art that the above embodiments
10 have been described by way of example only and not in any limitative sense, and that various alterations and modification are possible without departure from the scope of the invention as defined by the appended claims.

Throughout this specification and the claims which follow, unless the context requires otherwise, the word "comprise", and variations such as "comprises" and "comprising", will be understood to imply the inclusion of a stated integer or step or group of integers or steps but not the exclusion of any other integer or step or group of integers or steps.

The reference to any prior art in this specification is not, and should not be taken as, an acknowledgement or any form of suggestion that that prior art forms part of the common general knowledge in Australia.

THE CLAIMS DEFINING THE INVENTION ARE AS FOLLOWS:

1. A latch mechanism for a power tool having a housing, a motor provided in the housing, an output shaft adapted to be caused by said motor to actuate a working member, and a handle assembly adapted to pivot relative to the housing between a plurality of positions, the latch mechanism comprising:-
 - 5 first detent means having at least one first detent member adapted to move outwardly from the housing to engage said handle assembly to releasably retain the handle in at least one first said position;
second detent means having at least one second detent member adapted to pivot relative to the housing to engage said handle assembly to releasably retain the
10 handle assembly in at least one second said position; and
biasing means for urging at least one said first detent member and at least one said second detent member towards said handle assembly;
wherein said first detent means is connected to said second detent means such that movement relative to the housing of at least one said first or second detent
15 member not engaging the handle assembly releases said handle assembly from the corresponding said first or second detent means.
2. A mechanism according to claim 1, wherein at least one said detent member is adapted to be displaced against the action of said biasing means to enable the
20 housing to be pivoted into a said position, and to prevent said housing being pivoted out of said position.
3. A mechanism according to claim 1 or 2, further comprising at least one abutment surface provided on said handle assembly, wherein at least one said
25 abutment surface prevents further rotation of said housing when in at least one said position.
4. A mechanism according to any one of the preceding claims, wherein said handle assembly comprises integrally formed front and rear handles.
30
5. A mechanism according to any one of the preceding claims, wherein at least one said second detent member comprises a hook.

P-AU-GD1080BB

6. A mechanism according to any one of the preceding claims, wherein the biasing means comprises at least one helical spring.
7. A mechanism according to claim 6, wherein at least one said helical spring is disposed adjacent an inner surface of said housing.
8. A mechanism according to any one of the preceding claims, wherein at least one said position is a working position.
9. A mechanism according to any one of the preceding claims, wherein at least one said position is a storage position.
10. A latch mechanism for a power tool having a housing, a motor provided in the housing, an output shaft adapted to be caused by said motor to actuate a working member, and a handle assembly adapted to pivot relative to the housing between a plurality of positions, the latch mechanism substantially as hereinbefore described, with reference to Figures 2 to 17 of the accompanying drawings.
11. A power tool having a housing, a motor provided in the housing, an output shaft adapted to be caused by said motor to actuate a working member, a handle assembly adapted to pivot relative to the housing between a plurality of positions, and a latch mechanism according to any one of the preceding claims.
12. A power tool according to claim 11, wherein the power tool is a hedge trimmer.

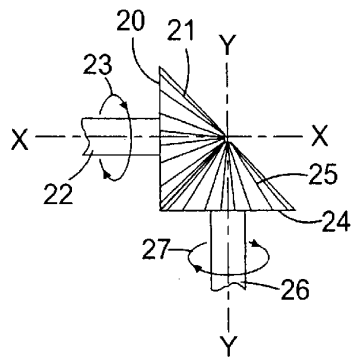

FIG.1
PRIOR ART

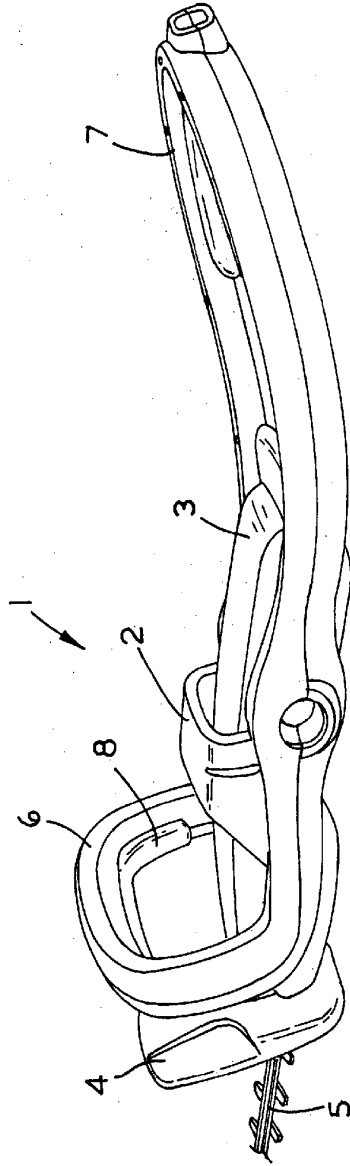

FIG. 2

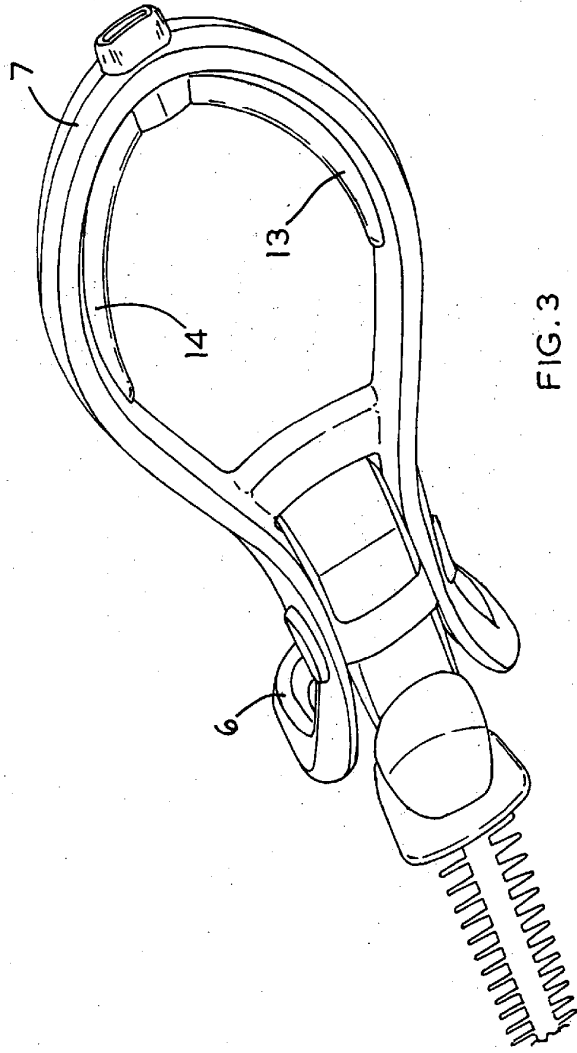

FIG. 3

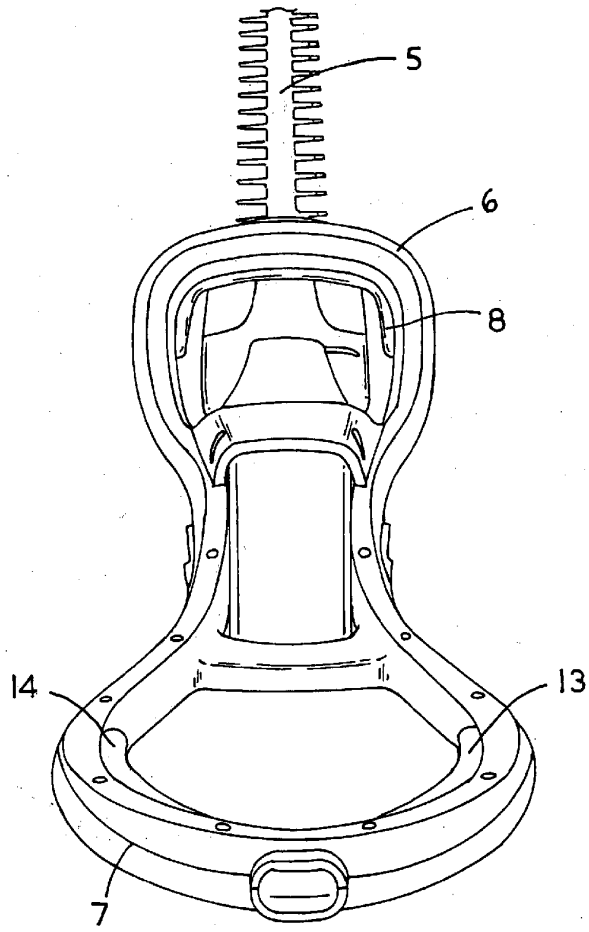

FIG. 4

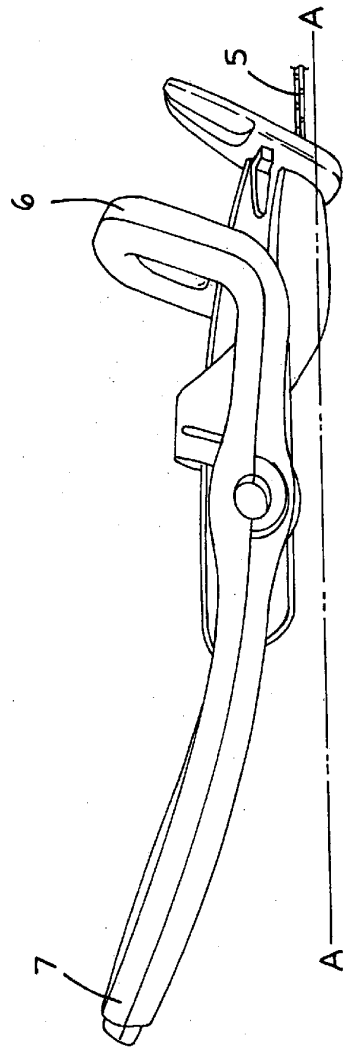

FIG. 5

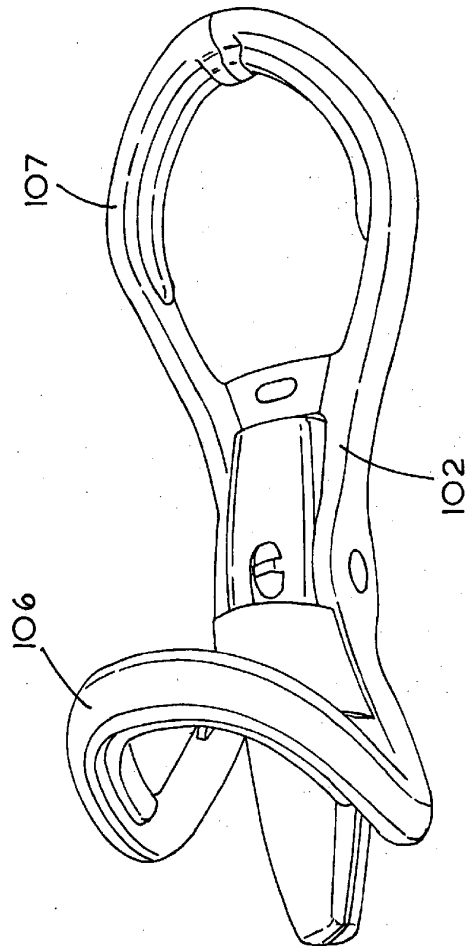

FIG. 6

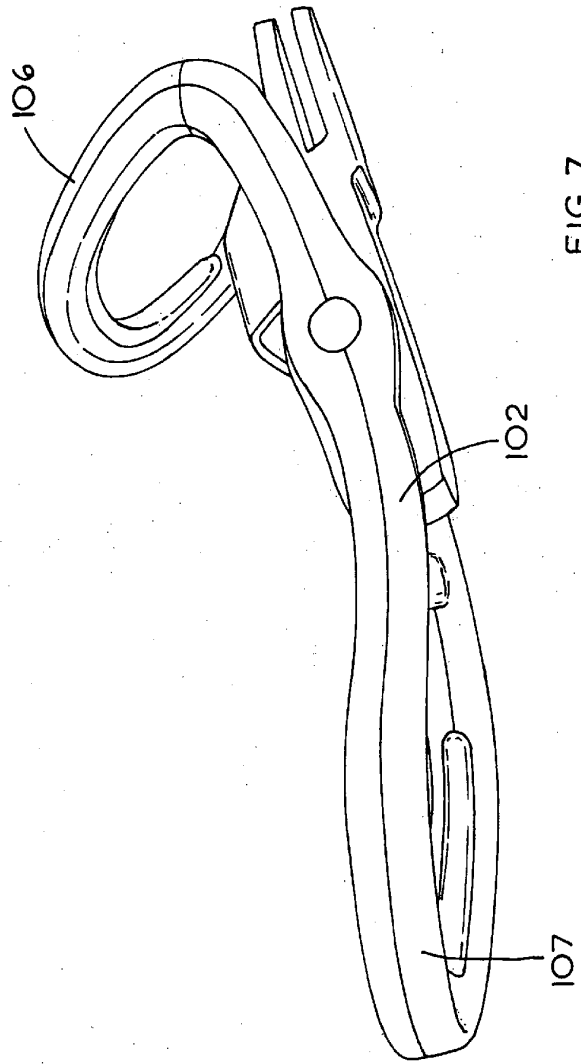

FIG. 7

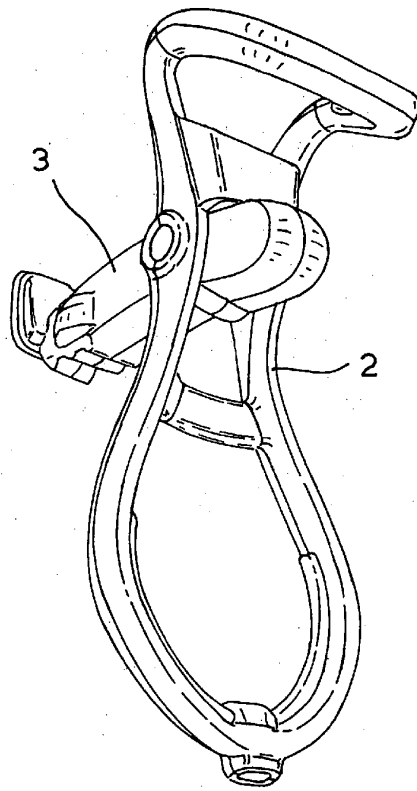

FIG. 8

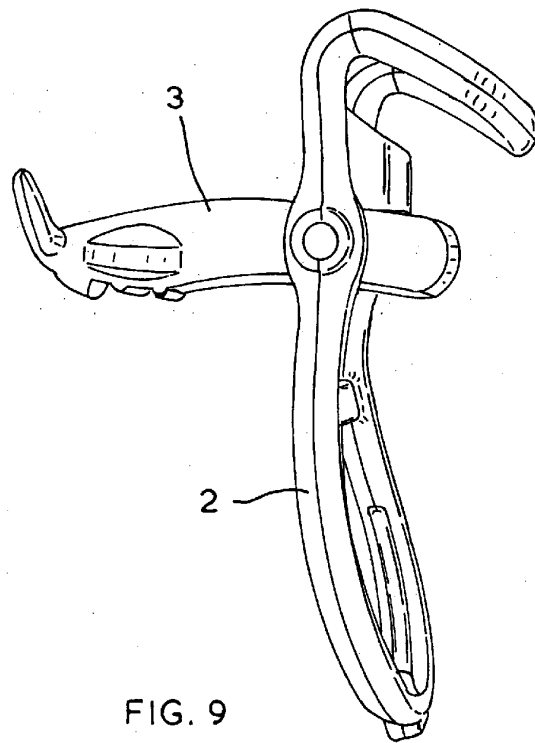
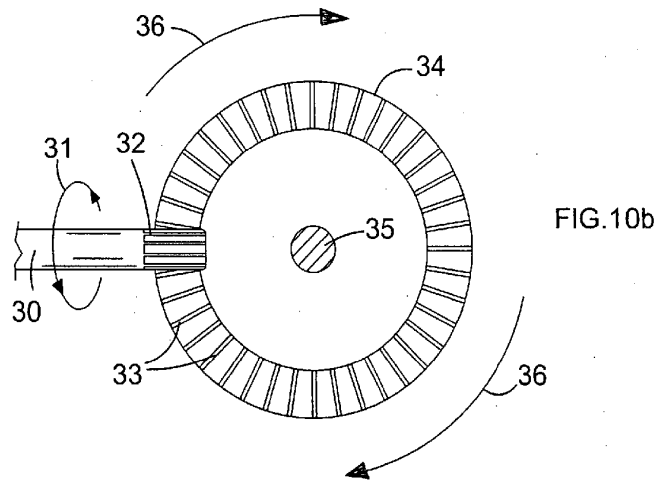
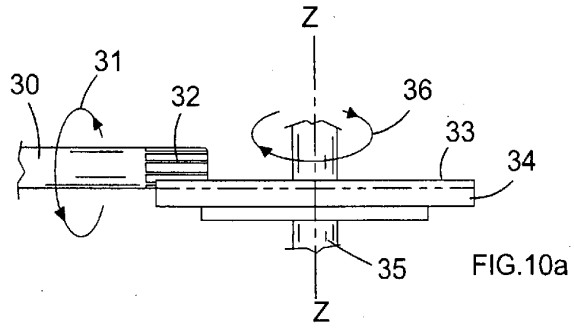

FIG. 9



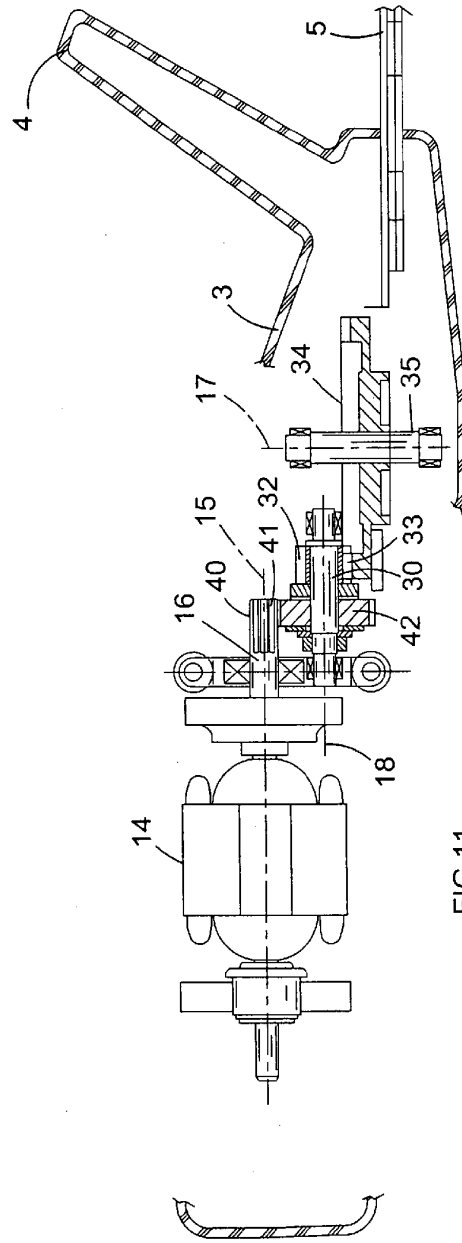

FIG. 11

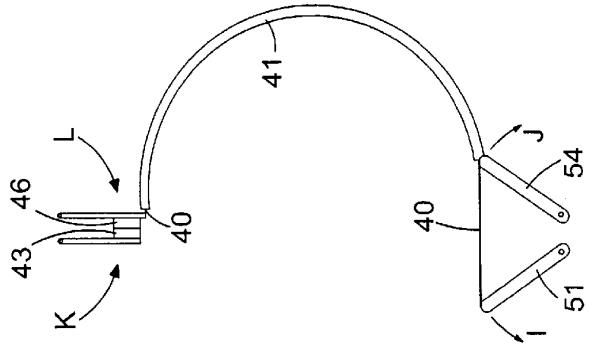

FIG. 13

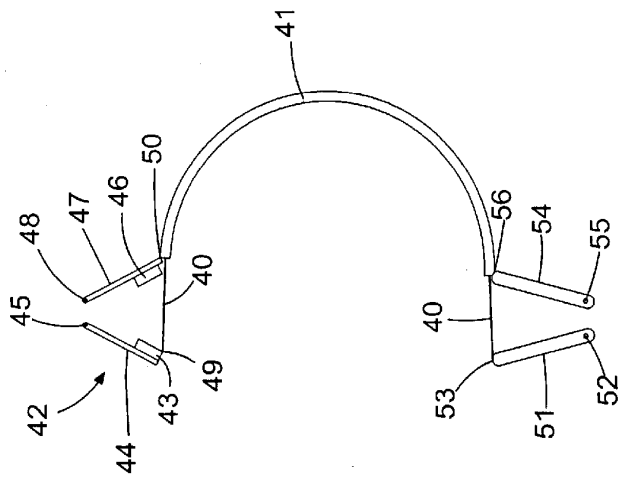

FIG. 12

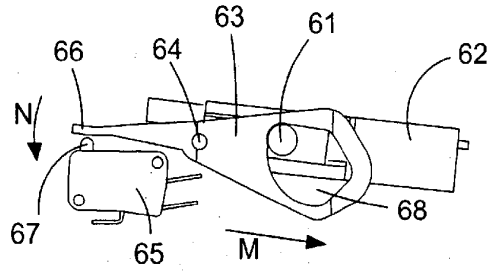

FIG. 14a

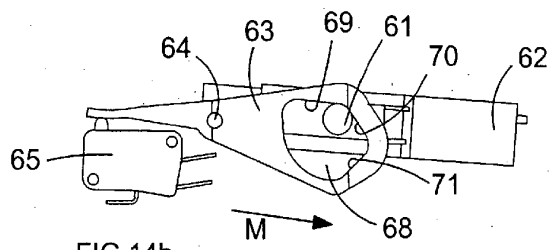

FIG. 14b

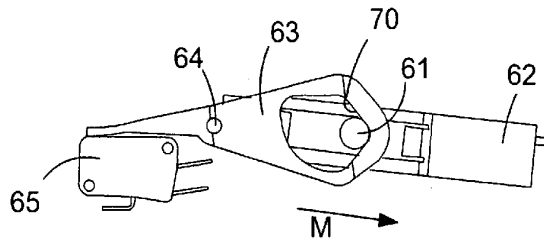

FIG. 14c

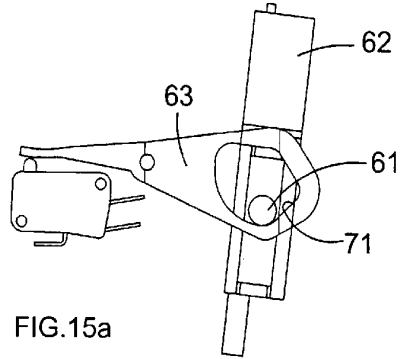

FIG. 15a

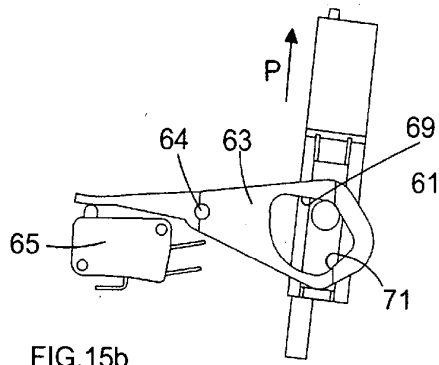

FIG. 15b

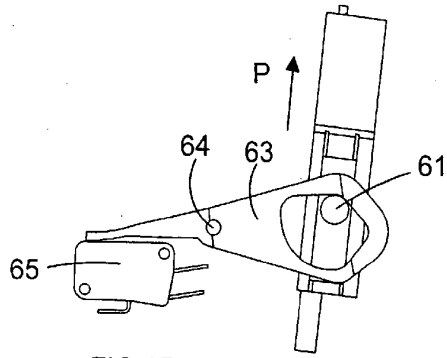

FIG. 15c

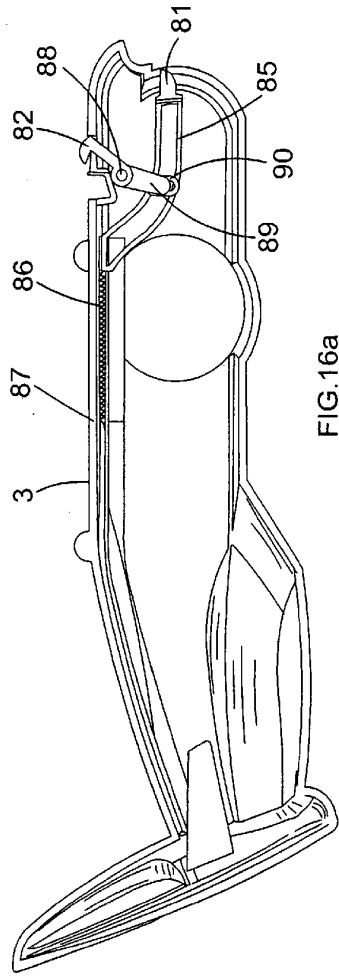

FIG. 16a

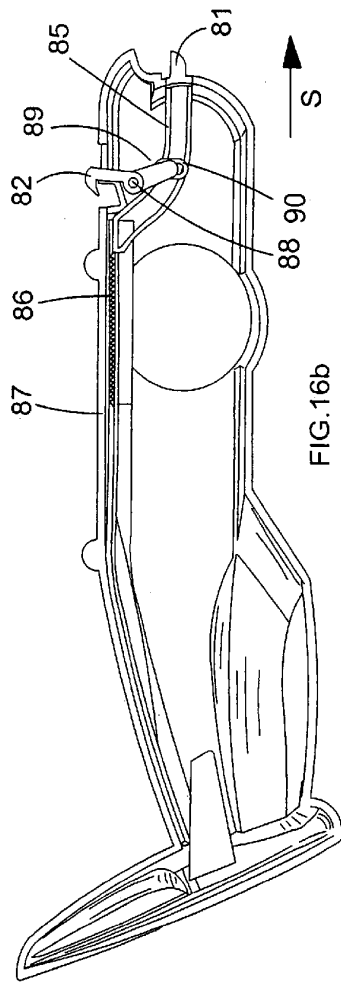

FIG. 16b

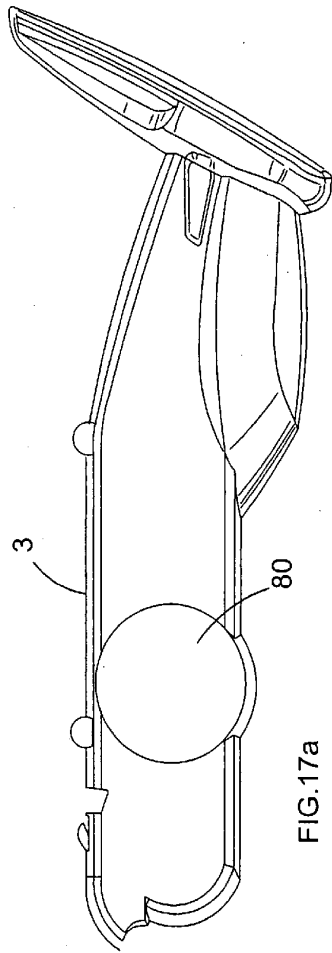

FIG. 17a

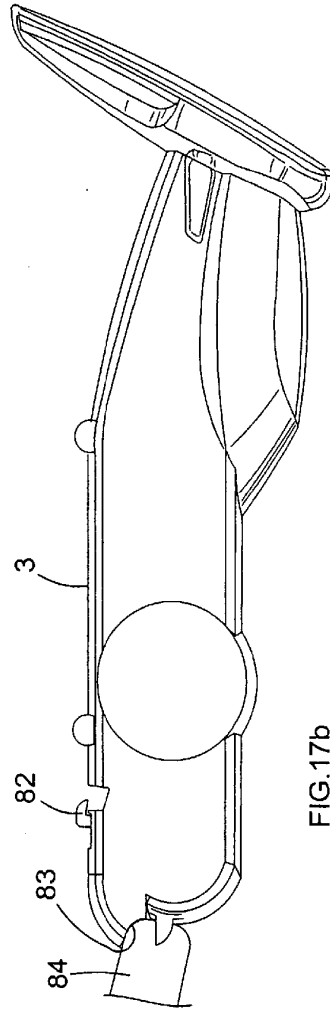

FIG. 17b