

Oct. 28, 1924.

1,513,425

D. W. ROBB

AIR HEATING ATTACHMENT FOR FURNACES

Filed May 15, 1922

2 Sheets-Sheet 1

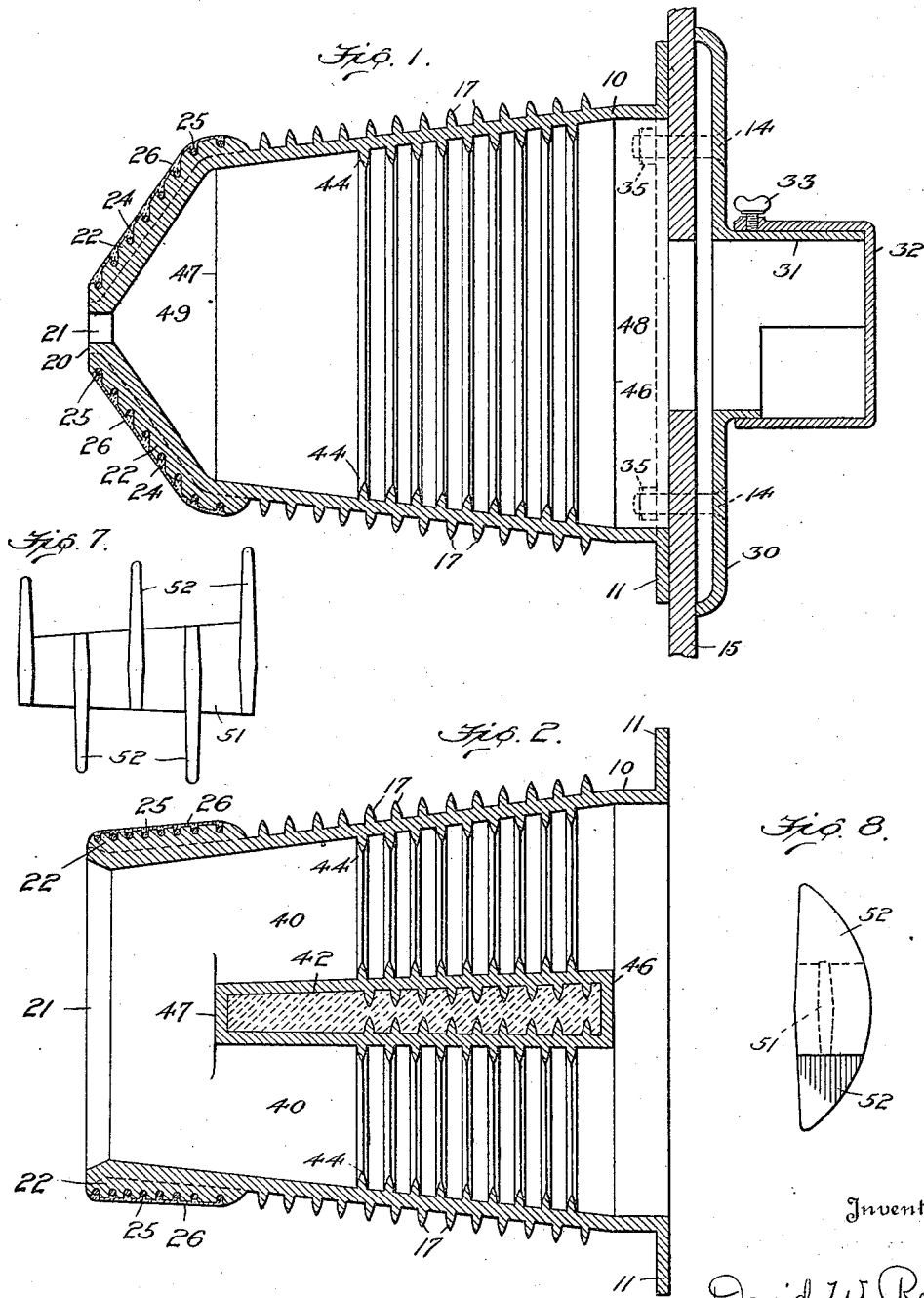

Inventor

David W. Robb

By Church & Church
His Attorneys

Oct. 28, 1924.

1,513,425

D. W. ROBB

AIR HEATING ATTACHMENT FOR FURNACES

Filed May 15, 1922

2 Sheets-Sheet 2

Fig. 3.

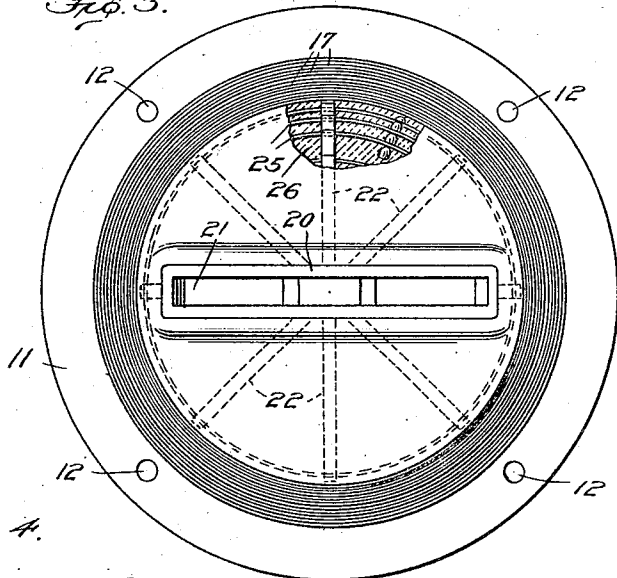

Fig. 4.

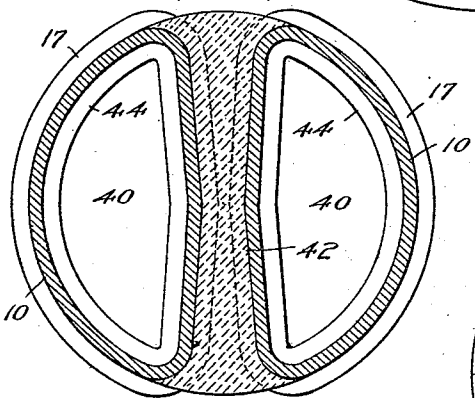

Fig. 5.

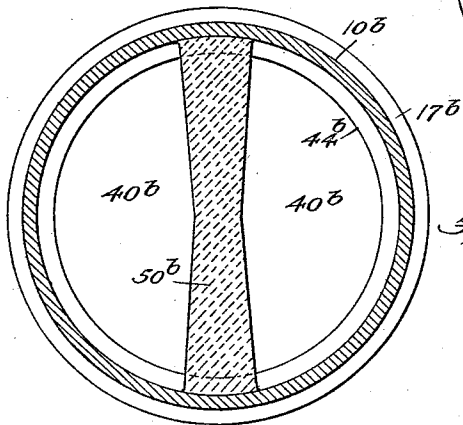
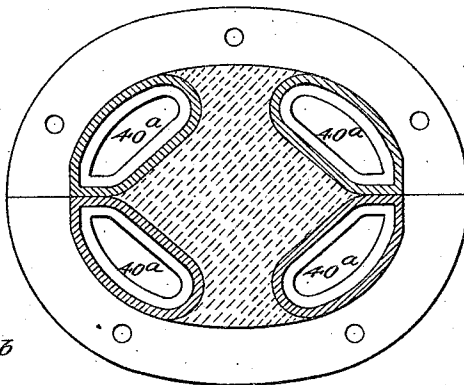

Fig. 6.

Inventor

David W. Robb

By Church & Church

His Attorneys

UNITED STATES PATENT OFFICE.

DAVID WENTWORTH ROBB, OF AMHERST, NOVA SCOTIA, CANADA.

AIR-HEATING ATTACHMENT FOR FURNACES.

Application filed May 15, 1922. Serial No. 561,252.

To all whom it may concern:

Be it known that I, DAVID WENTWORTH ROBB, a subject of the King of Great Britain, residing at Amherst, in the Province of Nova Scotia, Dominion of Canada, have invented certain new and useful Improvements in Air-Heating Attachments for Furnaces; and I do hereby declare the following to be a full, clear, and exact description of the same, reference being had to the accompanying drawings, forming part of this specification.

This invention relates to devices for use in connection with a furnace or a steam boiler and serving to heat the air drawn in over the top of the fire.

The principal object of the present invention is to provide a fuel saver of this type which will permit practically perfect combustion of the fuel.

A further object of the invention is to provide a fuel saver that is relatively simple to manufacture and which will serve efficiently throughout a relatively long life. A still further object of the invention is to provide novel means on the nozzle end of the air heater for attaching the refractory material coating necessary to prevent the burning out of the nozzle end and also to serve as a heat reservoir, absorbing heat when the furnace is hottest and yielding up this heat at the time when it is most needed, that is, after fresh coal has been added to the fire.

In the drawings,—

Figure 1 is a vertical section through the center of the device.

Fig. 2 is a horizontal section through the air heater.

Fig. 3 is an end view of the device taken from the nozzle end.

Fig. 4 is a vertical section through a slightly modified device.

Fig. 5 is a vertical section through a modification having four passageways.

Fig. 6 is a similar view through a second modification somewhat simpler than the other types, but also somewhat less efficient.

Figs. 7 and 8 are a side and an end elevation respectively of a baffle member which may be inserted in the passageways of the air heater.

In its preferred form the major portion 10 of the air heater is somewhat conical having a circular flange 11 at its larger or entrance end, this flange being perforated as at 12 to receive the bolts 14 by means of which the device is secured to the furnace door 15. This major portion 10 is provided with ribs 17 which may be separate annular ribs as shown or else may be formed by a single spiral rib running from one end to the other.

At its rear or inner end the main portion 10 merges into a flat nozzle portion 20 having an exit slot 21 relatively narrow in height but extending practically the entire diameter of the smaller portion of the conical part of the heater. The nozzle portion is provided with a plurality of ribs 22 which extend at right angles to the ribs 17 and are therefore radial with respect to the heater body. Each of these ribs, preferably four or more in number, are slotted as at 24 to receive wires 25. When the slots 24 are annular a separate wire 25 will be required for each circular channel, but if the slots are made so as to form a spiral channel a single wire may be used. The purpose of these ribs 22 and wires 25 is to securely hold in place the covering of refractory material 26 which covers the entire face or nose of the nozzle except the flat portion 20.

As previously stated the purpose of this refractory material is two-fold; first it preserves the casting and prevents it from being destroyed or burned out by the heat of the furnace, and second this refractory material absorbs and holds the heat so that when fresh coal is supplied to the fire or after the fuel door has been opened the heat retained in the fuel saver is given off at the very time when it is most needed, that is, after fresh fuel has been added to the fire with a consequent giving off of inflammable gases for the complete combustion of which the air supplied underneath the grate is not sufficient.

On the outside of the furnace door 15 is mounted an air regulator 30 consisting of a substantially cylindrical plate with a central boss 31 having a plurality of openings therein which openings are adapted to be covered either entirely or to any desired extent by

means of a rotatable cap 32 which may be locked in desired adjusted position by means of the wing-headed set screw 33. Preferably the bolts 14 are countersunk into the plate 30, pass through the door 15 and through the openings 12 in the flange 11, and receive nuts 35 for assembling together the air heater, the furnace door and the air regulator as a single unit.

In the preferred form shown in Figs. 1, 2 and 3, the main cone-shaped portion of the air heater is divided into two substantially oval passageways 40, the inner walls 14 of which are separated providing an open-ended space 42 which is filled with refractory material similar to the material 26 and serving the same purpose. As illustrated, the ribs 17 completely encircle each of the passageways 40 and each is provided in addition with similar ribs 44 on its interior which serve to prevent smooth passage of air and to form eddy currents so that a maximum of heat is absorbed by the air entering the regulator and passing to the furnace through the slot or mouth 21.

As best shown in Fig. 2 the two passageways 40 are separate only from the line 46 to the line 47 so that a single entrance chamber 48 is provided and a single exit chamber 49 which discharges through the outwardly diverging tapered mouth 21.

In the modification shown in Fig. 5, four passageways 40^a are provided, preferably formed as two pair, although they may be entirely separated if so desired. The construction in this modification is otherwise the same as in the preferred type, the principal advantage of the latter being the ease of molding and the less coring required.

A still further modification is shown in Fig. 6 in which the major portion 10^b of the air heater is a cone, the two passageways 40^b being formed by a block of refractory material molded into the interior of the air heater as shown. In this modification the metal may be readily cast as the outer and inner ribs 17^b and 44^b, respectively, are each perfectly annular. As will be seen, however, this type has not the high efficiency of the preferred form due to the interposition of the metal of the cone between this refractory material 50^b and the heat of the furnace.

The baffle shown in Figs. 7 and 8 is an optional member which may be inserted in the passageways 40. It consists of a plate 51 serving to connect a plurality of spaced wings 52 alternately projecting up and down to cause the air stream to take a tortuous path from the entrance to the exit or discharge end 21.

What I claim is:

1. In a device of the character described, a hollow member having a large entrance opening and a slot-like exit opening, and a septum within said member spaced from

either end to provide a plurality of passageways between said openings, each of said passageways being ribbed so as to form eddy currents.

2. In a device of the character described, a hollow member having a large entrance opening and a slot-like exit opening, a plurality of transverse ribs on the outer surface of said member in the central portion thereof, and a plurality of longitudinal ribs on said member in proximity to said exit opening.

3. In a device of the character described, an air preheater characterized by the provision of a main body portion and a flat nozzle discharge portion, said discharge portion having a plurality of ribs and a covering of refractory material covering said discharge portion and being held in place by said ribs.

4. In a device of the character described, an air preheater characterized by the provision of a main body portion and a flat nozzle discharge portion, said discharge portion having a plurality of circumferential grooves adapted to retain a covering of protective refractory material.

5. In an air preheater, a discharge member characterized by the provision of a plurality of spaced radial ribs each grooved to form a series of circumferential channels, wires in said channels and a covering of refractory material covering said ribs and embedding said wires.

6. In a device of the character described, an air heater consisting of a hollow conoid having a flat tapered nozzle at one end and an outwardly extending flange at the other end, a plurality of ribs on the outside of said conoid, said ribs being circumferential in the central portion of the device and radial at the nozzle portion, a wall separating said hollow conoid into two substantially oval passageways, circumferential ribs on the interior of each passageway, an air regulator having a cap for adjusting the size of openings in said regulator, and means for securing said regulator and said conoid to opposite sides of the furnace door.

7. An air heater consisting of a plurality of substantially parallel passageways having a single large entrance opening and a single narrow slot-like exit opening, each of said passageways being ribbed transversely both inside and outside.

8. An air heater consisting of a plurality of substantially parallel passageways having a single large entrance opening and a single narrow slot-like exit opening, and a filling of refractory material held in place between said passageways to absorb heat when the fire is hottest and to deliver said heat to the air when fresh coal has been put on the furnace and the heat of the latter is consequently lowered.

9. An air heater consisting of a plurality of substantially oval spaced passageways, ribbed inside and outside, a substantially cylindrical entrance member communicating with each of said passageways and adapted to be secured to a furnace door on the interior thereof, a tapered nozzle having an exit slot through which each of said passageways discharge, and refractory material covering said nozzle and also the space between said passageways, said material serving as a heat reservoir.

DAVID WENTWORTH ROBB.