

(No Model.)

T. ROBERTSON.  
CONFECTIONERY MACHINE.

No. 524,401.

Patented Aug. 14, 1894.

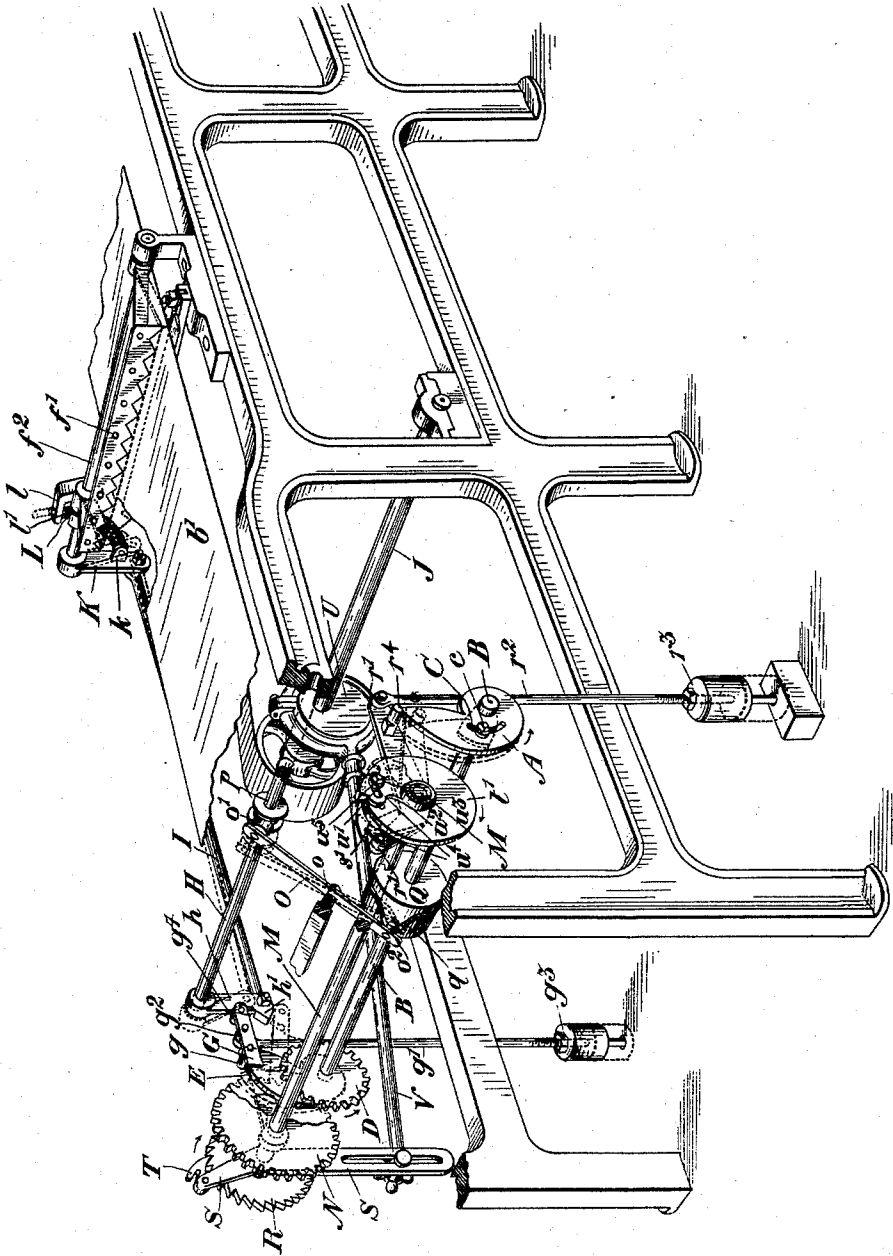

Witnesses.

W. W. Thrown.  
H. Young.

Inventor.

Thos. Robertson  
by Fetherstonhaugh & Co  
Atty

# UNITED STATES PATENT OFFICE.

THOMAS ROBERTSON, OF TORONTO, CANADA.

## CONFECTIONERY-MACHINE.

SPECIFICATION forming part of Letters Patent No. 521,401, dated August 14, 1894.

Application filed November 24, 1893. Serial No. 491,839. (No model.)

*To all whom it may concern:*

Be it known that I, THOMAS ROBERTSON, manufacturer, of the city of Toronto, in the county of York, in the Province of Ontario, Canada, have invented certain new and useful Improvements in Confectionery-Machines, of which the following is a specification.

My invention relates to improvements in confectionery machines patented to me in the United States of America under No. 488,404 on the 20th day of December, 1892, and the object of the present invention is, first, to provide an automatic means whereby the band of paper may be fed an increased space so as to enable it to be divided into sheets for convenience in handling and secondly, to provide an automatic means for manipulating the cutter to sever the band immediately upon the increased space coming beneath such cutter and it consists essentially, first, in providing a counter shaft suitably journaled in the frame of the machine, driven from the gear wheel of the shaft through which the feeding rolls are rotated, and providing a cam designed to co-act with a crank arm also journaled on the feed driving shaft, one end of said arm having an adjustable depending weight, while the other end is provided with a pivoted dog designed to engage with a tooth secured to the disk on the feed driving shaft and, secondly, in providing at the opposite end of the feed driving shaft an arm having a pin secured to it designed to co-act with the cam on the counter shaft, an adjustable depending weight and roller being also provided on the arm, which roller is designed to co-act at certain intervals with an arm secured on a shaft laterally adjustable by means of a pivoted lever operated from a serpentine cam on the counter shaft, this latter arm being connected by a pitman to another arm on the cutter spindle as hereinafter more particularly explained.

The drawing represents a perspective view of portion of the machine with the frame broken away and the feed rollers removed, so as to exhibit clearly only the parts involved in or directly connected with my present invention.

In the specification of my former patent I have described the manner in which the band of paper is fed by the feeding rolls and the

manner in which the increased space is produced in the band by the manipulation of the operator. I do not consider it necessary in this specification to go again into the feed any more than is necessary to explain the operation of my improvements.

M, is the shaft at one end of which is secured the spur wheel, N, through which the feed rollers for the band of paper are driven by suitable gear pinions meshing with each other. R, is the ratchet wheel, S, an arm, and T, is a dog pivoted at the upper end of the arm, S, and engaging with the ratchet wheel, R. U, is an eccentric fixed to the driving shaft, J, and provided with an eccentric rod, V, adjustably connected to the arm, S.  $t'$ , is a disk secured on the opposite end of the shaft, M, and  $r'$ , is a crank arm pivoted to said shaft and provided with a pivoted dog,  $s'$ .  $u'$ , is a projection secured on the periphery of the disk,  $t'$ , and designed to be engaged by the dog,  $s'$ , pivoted on the short end of the crank arm,  $r'$ . The projection,  $u'$ , extends laterally from the plate  $u^2$ , which has a boss,  $u^3$ , formed on it from which the shaft, M, extends.  $u^4$ , is a slot through which extends a bolt,  $u^5$ , into the disk,  $t'$ . By loosening the bolt the projection,  $u'$ , may be adjusted on the disk for the purpose of bringing the dog exactly behind the projection, and thereby overcoming any lost motion.  $f'$ , is the cutter and,  $b'$ , the band of paper. All of these parts I refer to in the specification of my former patent.

$r^2$ , is a rod pivotally attached to the end of the crank arm,  $r'$ . The lower end of the rod,  $r^2$ , is threaded and has screwed on to it a weight,  $r^3$ , which may be adjusted upon the rod, so as to allow of the weight having a greater or less drop according to the space it is designed to move the band as will be seen in the description hereinafter.

A, is a cam secured on the end of a counter shaft, B, which is journaled in suitable bearings in the frame of the machine. The counter shaft, B, has secured on the end inside the cam, A, a wing C, as indicated by dotted lines, and the cam, A, has an arc-shaped slot made in it through which passes a bolt, c. By unloosening the bolt the cam may be adjusted upon the shaft, B, so as to bring the end of the cam to a proper point so that weight will drop at the proper time.

$r^4$ , is a pin extending outwardly from the arm,  $r'$ , and projecting sufficiently to come within the sweep of the cam, A.

D, is a spur wheel secured on the opposite end of the shaft B, and meshing with the spur wheel, N, on the shaft, M. The spur wheel, N, is rotated in the direction indicated by arrow by means of the eccentric, U, pitman, V, arm, S, dog, T, and ratchet wheel R, on the end of the shaft, M. The spur wheel, D, is consequently rotated in the opposite direction thereby causing the cam, A, to rotate in the direction indicated by arrow.

E, is a cam located on the opposite end of the shaft, B, to that on which the cam, A, is situated, and to the outside of the spur wheel, D.

G, is an arm loosely journaled on the shaft, M, outside of the spur wheel, N. The arm, G, is provided with a pin,  $g$ , which extends outwardly from it so as to be within the sweep of the cam, E.  $g'$ , is a depending rod pivoted at,  $g^2$ , on the arm, G, and provided with a weight,  $g^3$ , which is vertically adjusted upon the threaded lower end of the rod,  $g'$ . The drop of the weights,  $r^3$ , and,  $g^3$ , on the depending rods,  $r^2$ , and,  $g'$ , regulates the movement of the arm,  $r'$ , and, G, respectively.  $g^4$ , is a friction roller secured on the end of the arm, G and bearing against the arm  $h$ .

H, is a rock shaft suitably journaled in the frame of the machine and provided with an arm,  $h$ , with an inclined end,  $h'$ . The arm,  $h$ , is connected by the pitman, I, to the arm, K, secured on the end of the spindle,  $f^2$ , of the cutter,  $f'$ .

L, is a curved spindle having one end secured to the lug,  $k$ , of the arm, K, and the other end extending through a bracket,  $l$ .

$l'$ , is a spiral spring extending between the lug,  $k$ , and the bracket,  $l$ . This spring is designed to throw the cutter up after cutting the band of paper, and the arm,  $h$ , into its normal position.

O, is a lever pivoted at,  $o$ , in the frame of the machine as indicated, and provided at its upper end with a friction roller  $o'$ , which extends into a grooved collar, P, secured to the shaft, H. The lower end of the lever has a pin or roller,  $o^2$ , which extends into the serpentine cam groove,  $q$ , in the collar, Q, which is attached to the counter shaft, B. The operation of this serpentine cam grooved lever and collar,  $o'$ , is to laterally adjust the shaft, H, at certain intervals, so as to bring the inclined end,  $h'$ , of the arm,  $h$ , directly opposite to or away from the sweep of the roller,  $g^2$ , on the end of the arm, G.

Having now described the principal parts involved in my invention I shall briefly describe the operation.

The ordinary space necessary for the delivery of the drops on the band is fed successively by the dog, T, engaging with the ratchet wheel, R, on the end of the shaft, M, and communicating motion by means of the spur wheel, N, to the feed rollers described in

my former patent. The band is fed forward ordinarily as before described by the dog, T, engaging each successive tooth of the ratchet wheel, R, so as to give the ordinary space between the drops. The cam, A, moving around in the direction indicated by arrow comes beneath the pin,  $r^4$ , projecting from the arm,  $r'$ . The cam when it has about reached its greatest radius from the counter shaft, B, lifts the pin,  $r^4$ , so as to throw the dog back behind the projection,  $u'$ . When the end of the cam passes the pin,  $r^4$ , the weight,  $r^3$ , causes the long arm of the crank arm,  $r'$ , to drop, thereby causing the dog,  $s'$ , to throw the projection and consequently the disk forward a space corresponding to the drop of the weight. This quick motion is communicated through the feeding shaft M, and through the spur wheel, N, to the feed rollers, so that the band is thrown forward a double space or more, this of course depending on the drop of the weight, so as to provide a sufficient space between the drops for the cutter to sever the band. The jumping feed of the disk,  $l'$ , is of course repeated as the band passes through the machine, so as to form the increased spaces at equal distances apart throughout the band. The space between the tubes and the cutter corresponds as described in my former patent to the length of the sheet. Consequently the cutter, when the band is fed forward the space beneath the tubes, acts instantaneously to sever the band in the space beneath it and this is accomplished automatically in the following manner: At the time that the cam, A, has passed beneath the pin,  $r^4$ , on the arm,  $r'$ , the pin,  $g$ , has almost reached the end of the cam, E, on the opposite end of the shaft, B, in fact so nearly so that upon the arm,  $r'$ , dropping the arm, G, drops immediately afterward. At this period the lever, O, is thrown into the position shown by dotted lines by the cam groove,  $q$ , so as to throw the shaft,  $h$ , laterally and bring the inclined end,  $h'$ , within the sweep of the roller,  $g^2$ , on the end of the arm, which roller as the arm drops forces the arm in the position shown in dotted lines thereby instantaneously causing the cutter to come down and sever the band. The roller,  $o^2$ , on the end of the lever now passes into the straight portion of the groove drawing the arm,  $h$ , outside the sweep of the arm,  $g$ . The cam, E, as it comes around again raises the arm,  $g$ , and the operation is repeated successively, so that the cutter will sever the band instantaneously upon the band being moved the increased space.

By the means above described I am therefore enabled to produce a machine for making drops, which is automatic throughout its action and requires no attention on the part of the attendant except to remove the sheets of drops after they have been severed from the main body of the band.

What I claim as my invention is—

1. The combination with the feed driving

shaft M connected to the feed rollers by spur gearing, the shaft, J, the eccentric U thereon, pitman, V, arm, S, dog, T, and ratchet wheel, R, of the disk,  $t'$ , on the opposite end of the shaft M, and having a projection,  $w'$ , the arm,  $r'$ , provided with a dog,  $s'$ , designed to engage with the projection,  $w'$ , and having a pin,  $r^4$ , and a depending rod,  $r^2$ , with an adjustable weight,  $r^3$ , and the cam, A, secured on the end of the shaft, B, designed to co-act with the pin,  $r^4$ , on the arm,  $r'$ , as and for the purpose specified.

2. The combination with the feed driving shaft M, connected to the feed rollers by spur gearing, the shaft, J, the eccentric U thereon, pitman, V, arm, S, dog, T, and ratchet wheel, R, of the disk,  $t'$ , on the opposite end of the shaft M, and having a projection,  $w'$ , the arm,  $r'$ , provided with a dog,  $s'$ , designed to engage with the projection,  $w'$ , and having a pin,  $r^4$ , and a depending rod,  $r^2$ , with an adjustable weight,  $r^3$ , the cam, A, secured at one end of the shaft, B, and the spur wheel, D, secured on the opposite end of the shaft, B, and meshing with the spur wheel, N, on the end of the shaft, M, as and for the purpose specified.

3. The combination with the feed driving shaft M connected to the feed rollers by spur gearing and operated as specified, of the arm G loosely journaled on the shaft M, and provided with a depending rod  $g'$  having an adjustable weight  $g^3$ , a pin  $g$  secured to the arm, the shaft B, the cam E secured thereon, and engaging pin  $g$ , a roller  $g^2$  also pivoted on the

end of the arm, the shaft H, arm  $h$  secured thereto and provided with the inclined bottom  $h'$  with which roller  $g^2$  engages, arm K, pitman I connecting the said arm to shaft H, cutter  $f'$  operated by arm K and means whereby the arm  $h$  is brought laterally within the sweep of the roller on the arm  $g^2$  when it is caused to descend and outside the sweep of such roller when the arm is caused to ascend and for the purpose specified.

4. The combination with the feed driving shaft M connected to the feed roller by spur gearing and operated as specified, of the arm G loosely journaled on the shaft M, and provided with a depending rod  $g'$  having an adjustable weight  $g^3$ , a pin  $g$ , secured to the arm, the shaft B, the cam E secured thereon, and engaging pin  $g$ , a roller  $g^2$  also pivoted on the end of the arm, the shaft H, arm  $h$  secured thereto and provided with the inclined bottom  $h'$  with which roller  $g^2$  engages, arm K, pitman I connecting the said arm to shaft H, cutter  $f'$  operated by arm K and the lever O pivoted at  $o$  and provided at the upper end with a roller  $o'$ , the shaft H having collar  $p$  engaging roller  $o'$ , the collar Q secured to the shaft B and having the serpentine groove therein, and the pin roller  $o^2$  on the lower end of the lever engaging said groove, as and for the purpose specified.

THOMAS ROBERTSON.

Witnesses:

B. BOYD,  
E. R. CASE.