

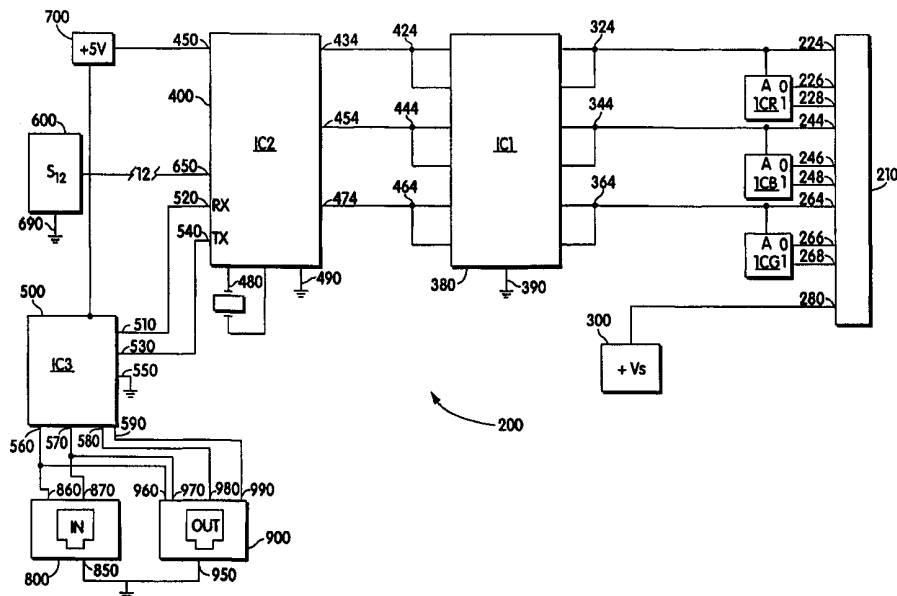

INTERNATIONAL APPLICATION PUBLISHED UNDER THE PATENT COOPERATION TREATY (PCT)

<p>(51) International Patent Classification <sup>6</sup> : <b>G09G 3/32, H05B 37/02</b></p>	<p><b>A1</b></p>	<p>(11) International Publication Number: <b>WO 99/10867</b> (43) International Publication Date: 4 March 1999 (04.03.99)</p>
<p>(21) International Application Number: PCT/US98/17702 (22) International Filing Date: 26 August 1998 (26.08.98) (30) Priority Data: 08/920,156 26 August 1997 (26.08.97) US (71) Applicant: COLOR KINETICS INCORPORATED [US/US]; 50 Milk Street, Boston, MA 02109 (US). (72) Inventors: MUELLER, George, G.; 234 Hanover Street #3, Boston, MA 02113 (US). LYS, Ihor, A.; Apartment #6, 5 Hull Street, Boston, MA 02113 (US). (74) Agents: CELLA, Charles, H. et al.; Foley, Hoag &amp; Eliot, LLP, One Post Office Square, Boston, MA 02109 (US).</p>		<p>(81) Designated States: AL, AM, AT, AU, AZ, BA, BB, BG, BR, BY, CA, CH, CN, CU, CZ, DE, DK, EE, ES, FI, GB, GE, GH, GM, HR, HU, ID, IL, IS, JP, KE, KG, KP, KR, KZ, LC, LK, LR, LS, LT, LU, LV, MD, MG, MK, MN, MW, MX, NO, NZ, PL, PT, RO, RU, SD, SE, SG, SI, SK, SL, TJ, TM, TR, TT, UA, UG, UZ, VN, YU, ZW, ARIPO patent (GH, GM, KE, LS, MW, SD, SZ, UG, ZW), Eurasian patent (AM, AZ, BY, KG, KZ, MD, RU, TJ, TM), European patent (AT, BE, CH, CY, DE, DK, ES, FI, FR, GB, GR, IE, IT, LU, MC, NL, PT, SE), OAPI patent (BF, BJ, CF, CG, CI, CM, GA, GN, GW, ML, MR, NE, SN, TD, TG).</p> <p><b>Published</b> <i>With international search report. Before the expiration of the time limit for amending the claims and to be republished in the event of the receipt of amendments.</i></p>

(54) Title: MULTICOLORED LED LIGHTING METHOD AND APPARATUS



(57) Abstract

Disclosed herein is a current control for a lighting assembly, which may be an LED lighting assembly, which may be a pulse width modulated ("PWM") current control or other form of current control where each current-controlled unit is uniquely addressable and capable of receiving illumination color information on a computer lighting network. In an embodiment, the invention includes a binary tree network configuration of lighting units (nodes). In another embodiment, the present invention comprises a heat dissipating housing, made out of a heat-conductive material, for housing the lighting assembly. The heat dissipating housing contains two stacked circuit boards holding respectively the power module and the light module. The light module is adapted to be conveniently interchanged with other light modules.

**FOR THE PURPOSES OF INFORMATION ONLY**

Codes used to identify States party to the PCT on the front pages of pamphlets publishing international applications under the PCT.

AL	Albania	ES	Spain	LS	Lesotho	SI	Slovenia
AM	Armenia	FI	Finland	LT	Lithuania	SK	Slovakia
AT	Austria	FR	France	LU	Luxembourg	SN	Senegal
AU	Australia	GA	Gabon	LV	Latvia	SZ	Swaziland
AZ	Azerbaijan	GB	United Kingdom	MC	Monaco	TD	Chad
BA	Bosnia and Herzegovina	GE	Georgia	MD	Republic of Moldova	TG	Togo
BB	Barbados	GH	Ghana	MG	Madagascar	TJ	Tajikistan
BE	Belgium	GN	Guinea	MK	The former Yugoslav Republic of Macedonia	TM	Turkmenistan
BF	Burkina Faso	GR	Greece	ML	Mali	TR	Turkey
BG	Bulgaria	HU	Hungary	MN	Mongolia	TT	Trinidad and Tobago
BJ	Benin	IE	Ireland	MR	Mauritania	UA	Ukraine
BR	Brazil	IL	Israel	MW	Malawi	UG	Uganda
BY	Belarus	IS	Iceland	MX	Mexico	US	United States of America
CA	Canada	IT	Italy	NE	Niger	UZ	Uzbekistan
CF	Central African Republic	JP	Japan	NL	Netherlands	VN	Viet Nam
CG	Congo	KE	Kenya	NO	Norway	YU	Yugoslavia
CH	Switzerland	KG	Kyrgyzstan	NZ	New Zealand	ZW	Zimbabwe
CI	Côte d'Ivoire	KP	Democratic People's Republic of Korea	PL	Poland		
CM	Cameroon	KR	Republic of Korea	PT	Portugal		
CN	China	KZ	Kazakstan	RO	Romania		
CU	Cuba	LC	Saint Lucia	RU	Russian Federation		
CZ	Czech Republic	LI	Liechtenstein	SD	Sudan		
DE	Germany	LK	Sri Lanka	SE	Sweden		
DK	Denmark	LR	Liberia	SG	Singapore		
EE	Estonia						

## MULTICOLORED LED LIGHTING METHOD AND APPARATUS

### CROSS REFERENCE TO RELATED APPLICATIONS

This application is based on United States Patent Application No.  
5 08/920,156, filed August 26, 1997. Priority is claimed to such United States Patent  
Application, and the entire disclosure of such United States Patent Application is  
incorporated by reference herein.

### BACKGROUND OF THE INVENTION

10 The present invention relates to providing light of a selectable color using  
light sources, such as LEDES. More particularly, the present invention is a method  
and apparatus for providing multicolored illumination. More particularly still, the  
present invention is an apparatus for providing a computer controlled multicolored  
illumination network capable of high performance and rapid color selection and  
15 change.

It is well known that combining the projected light of one color with the  
projected light of another color will result in the creation of a third color. It is also  
well known that the three most commonly used primary colors -- red, blue and green  
-- can be combined in different proportions to generate almost any color in the visible  
20 spectrum. The present invention takes advantage of these effects by combining the  
projected light from at least two light emitting diodes (LEDES) of different primary  
colors. It should be understood that for purposes of this invention the term "primary  
colors" encompasses any different colors that can be combined to create other colors.

Computer lighting networks are not new. U.S. Patent No. 5,420,482, issued  
25 to Phares, describes one such network that uses different colored LEDs to generate a  
selectable color. Phares is primarily for use as a display apparatus. However, the  
apparatus has several disadvantages and limitations. First, each of the three color  
LEDs in Phares is powered through a transistor biasing scheme in which the  
transistor base is coupled to a respective latch register through biasing resistors. The  
30 three latches are all simultaneously connected to the same data lines on the data bus.

This means it is impossible in Phares to change all three LED transistor biases independently and simultaneously. Also, biasing of the transistors is inefficient because power delivered to the LEDs is smaller than that dissipated in the biasing network. This makes the device poorly suited for efficient illumination applications.

5 The transistor biasing used by Phares also makes it difficult, if not impossible, to interchange groups of LEDs having different power ratings, and hence different intensity levels.

U.S. Patent No. 4,845,481, issued to Havel, is directed to a multicolored display device. Havel addresses some, but not all of the switching problems associated with Phares. Havel uses a pulse width modulated signal to provide current to respective LEDs at a particular duty cycle. However, no provision is made for precise and rapid control over the colors emitted. As a stand alone unit, the apparatus in Havel suggests away from network lighting, and therefore lacks any teaching as to how to implement a pulse width modulated computer lighting network.

10

15 Further, Havel does not appreciate the use of LEDs beyond mere displays, such as for illumination.

U.S. Patent No. 5,184,114, issued to Brown, shows an LED display system. But Brown lacks any suggestion to use LEDs for illumination, or to use LEDs in a configurable computer network environment. U.S. Patent No. 5,134,387, issued to Smith et al., directed to an LED matrix display, contains similar problems. Its rudimentary current control scheme severely limits the possible range of colors that can be displayed.

20

Disclosed herein is a high performance computer controlled multicolored lighting network, which may be an LED lighting network.

25 Disclosed herein is a LED lighting network structure capable of both a linear chain of nodes and a binary tree configuration.

Disclosed herein is a heat-dissipating housing to contain the lighting units of the lighting network.

Disclosed herein is a current regulated LED lighting apparatus, wherein the apparatus contains lighting modules each having its own maximum current rating and each conveniently interchangeable with one another.

Disclosed herein is a computer current-controlled LED lighting assembly for use as a general illumination device capable of emitting multiple colors in a continuously programmable 24-bit spectrum.

Disclosed herein are a flashlight, inclinometer, thermometer, general environmental indicator and lightbulb, all utilizing the general computer current-control principles of the present invention.

Other aspects of the present disclosure will be apparent from the detailed description below.

### **SUMMARY OF THE INVENTION**

In brief, disclosed herein is a current control for a lighting assembly, which may be an LED lighting assembly, which may be a pulse width modulated ("PWM") current control or other form of current control where each current-controlled unit is uniquely addressable and capable of receiving illumination color information on a computer lighting network. In a further embodiment, the invention includes a binary tree network configuration of lighting units (nodes). In another embodiment, the present invention comprises a heat dissipating housing, made out of a heat-conductive material, for housing the lighting assembly. The heat dissipating housing contains two stacked circuit boards holding respectively the power module and the light module. The light module is adapted to be conveniently interchanged with other light modules having programmable current, and hence maximum light intensity, ratings. Such other light modules may include organic LEDs, electro-luminescent strips, and other modules, in addition to conventional LEDs. Other embodiments of the present invention involve novel applications for the general principles described herein.

### **DESCRIPTION OF THE DRAWINGS**

Figure I is a stylized electrical circuit schematic of the light module of the present invention.

Figure 2 is a stylized electrical circuit schematic of the power module of the present invention.

Figure 3 is an exploded view of the housing of one of the embodiments of the present invention.

5 Figure 4 is a plan view of the LED-containing side of the light module of the present invention.

Figure 5 is a plan view of the electrical connector side of the light module of the present invention.

10 Figure 6 is a plan view of the power terminal side of the power module of the present invention.

Figure 7 is a plan view of the electrical connector side of the power module of the present invention.

Figure 8 is an exploded view of a flashlight assembly containing the LED lighting module of the present invention.

15 Figure 9 is a control block diagram of the environmental indicator of the present invention.

#### **DETAILED DESCRIPTION**

The structure and operation of a preferred embodiment will now be described. It should be understood that many other ways of practicing the inventions herein are available, and the embodiments described herein are exemplary and not limiting.

20 Turning to Figure 1, shown is an electrical schematic representation of a light module 100 of the present invention. Figures 4 and 5 show the LED-containing side and the electrical connector side of light module 100. Light module 110 is self-contained, and is configured to be a standard item interchangeable with any similarly constructed light module. Light module 100 contains a ten-pin electrical connector 110 of the

25 general type. In this embodiment, the connector 110 contains male pins adapted to fit into a complementary ten-pin connector female assembly, to be described below. Pin 180 is the power supply. A source of DC electrical potential enters module 100 on pin 180. Pin 180 is electrically connected to the anode end of light emitting diode (LED) sets 120, 140 and 160 to establish a uniform high potential on each anode end.

30

LED set 120 contains red LEDs, set 140 contains blue and set 160 contains green, each obtainable from the Nichia America Corporation. These LEDs are primary colors, in the sense that such colors when combined in preselected proportions can generate any color in the spectrum. While three primary colors is preferred, it will be understood that the present invention will function nearly as well with only two primary colors to generate any color in the spectrum. Likewise, while the different primary colors are arranged herein on sets of uniformly colored LEDs, it will be appreciated that the same effect may be achieved with single LEDs containing multiple color-emitting semiconductor dies. LED sets 120, 140 and 160 each preferably contains a serial/parallel array of LEDs in the manner described by Okuno in U.S. Patent No. 4,298,869, incorporated herein by reference. In the present embodiment, LED set 120 contains three parallel connected rows of nine red LEDs (not shown), and LED sets 140 and 160 each contain five parallel connected rows of five blue and green LEDs, respectively (not shown). It is understood by those in the art that, in general, each red LED drops the potential in the line by a lower amount than each blue or green LED, about 2.1 V, compared to 4.0 V, respectively, which accounts for the different row lengths. This is because the number of LEDs in each row is determined by the amount of voltage drop desired between the anode end at the power supply voltage and the cathode end of the last LED in the row. Also, the parallel arrangement of rows is a fail-safe measure that ensures that the light module 100 will still function even if a single LED in a row fails, thus opening the electrical circuit in that row. The cathode ends of the three parallel rows of nine red LEDs in LED set 120 are then connected in common, and go to pin 128 on connector 110. Likewise, the cathode ends of the five parallel rows of five blue LEDs in LED set 140 are connected in common, and go to pin 148 on connector 110. The cathode ends of the five parallel rows of five green LEDs in LED set 160 are connected in common, and go to pin 168 on connector 110. Finally, on light module 100, each LED set is associated with a programming resistor that combines with other components, described below, to program the maximum current through each set of LEDs. Between pin 124 and 126 is resistor 122, 6.2  $\Omega$ . Between pin 144 and 146 is resistor

142, 4.7  $\Omega$ . Between pin 164 and 166 is resistor 162, 4.7  $\Omega$ . Resistor 122 programs maximum current through red LED set 120, resistor 142 programs maximum current through blue LED set 140, and resistor 162 programs maximum current through green LED set 160. The values these resistors should take are determined  
5 empirically, based on the desired maximum light intensity of each LED set. In the present embodiment, the resistances above program red, blue and green currents of 70, 50 and 50  $\mu\text{A}$ , respectively.

With the electrical structure of light module 100 described, attention will now be given to the electrical structure of power module 200, shown in Figure 2. Figures  
10 6 and 7 show the power terminal side and electrical connector side of an embodiment of power module 200. Like light module 100, power module 200 is self contained. Interconnection with male pin set 110 is achieved through complementary female pin set 210. Pin 280 connects with pin 180 for supplying power, delivered to pin 280 from supply 300. Supply 300 is shown as a functional block for simplicity. In  
15 actually, supply 300 can take numerous forms for generating a DC voltage. In the present embodiment, supply 300 provides 24 Volts through a connection terminal (not shown), coupled to pin 280 through transient protection capacitors (not shown) of the general type. It will be appreciated that supply 300 may also supply a DC  
20 voltage after rectification and/or voltage transformation of an AC supply, as described more fully in U.S. Patent No. 4,298,869.

Also connected to pin connector 210 are three current programming integrated circuits, ICR 220, ICB 240 and ICG 260. Each of these is a three terminal adjustable regulator, preferably part number LM317B, available from the National  
25 Semiconductor Corporation, Santa Clara, California. The teachings of the LM317 datasheet are incorporated herein by reference. Each regulator contains an input terminal, an output terminal and an adjustment terminal, labeled I, O, and A, respectively. The regulators function to maintain a constant maximum current into the input terminal and out of the output terminal. This maximum current is pre-programmed by setting a resistance between the output and the adjustment terminals.  
30 This is because the regulator will cause the voltage at the input terminal to settle to



whatever value is needed to cause 1.25 V to appear across the fixed current set resistor, thus causing constant current to flow. Since each functions identically, only ICR 220 will now be described. First, current enters the input terminal of ICR 220 from pin 228. Of course, pin 228 in the power module is coupled to pin 128 in the light module, and receives current directly from the cathode end of the red LED set 120. Since resistor 122 is ordinarily disposed between the output and adjustment terminals of ICR 220 through pins 224/124 and 226/126, resistor 122 programs the amount of current regulated by ICR 220. Eventually, the current output from the adjustment terminal of ICR 220 enters a Darlington driver. In this way, ICR 220 and associated resistor 122 program the maximum current through red LED set 120. Similar results are achieved with ICB 240 and resistor 142 for blue LED set 140, and with ICG 260 and resistor 162 for green LED set 160.

The red, blue and green LED currents enter another integrated circuit, ICI 380, at respective nodes 324, 344 and 364. ICI 380 is preferably a high current/voltage Darlington driver, part no. DS2003 available from the National Semiconductor Corporation, Santa Clara, California. ICI 380 is used as a current sink, and functions to switch current between respective LED sets and ground 390. As described in the DS2003 datasheet, incorporated herein by reference, ICI contains six sets of Darlington transistors with appropriate on-board biasing resistors. As shown, nodes 324, 344 and 364 couple the current from the respective LED sets to three pairs of these Darlington transistors, in the well known manner to take advantage of the fact that the current rating of ICI 380 may be doubled by using pairs of Darlington transistors to sink respective currents. Each of the three on-board Darlington pairs is used in the following manner as a switch. The base of each Darlington pair is coupled to signal inputs 424, 444 and 464, respectively. Hence, input 424 is the signal input for switching current through node 324, and thus the red LED set 120. Input 444 is the signal input for switching current through node 344, and thus the blue LED set 140. Input 464 is the signal input for switching current through node 364, and thus the green LED set 160. Signal inputs 424, 444 and 464 are coupled to respective signal outputs 434, 454 and 474 on microcontroller IC2

400, as described below. In essence, when a high frequency square wave is incident on a respective signal input, ICI 380 switches current through a respective node with the identical frequency and duty cycle. Thus, in operation, the states of signal inputs 424, 444 and 464 directly correlate with the opening and closing of the power circuit through respective LED sets 120, 140 and 160.

The structure and operation of microcontroller IC2 400 will now be described. Microcontroller IC2 400 is preferably a MICROCHIP brand PIC16C63, although almost any properly programmed microcontroller or microprocessor can perform the software functions described herein. The main function of microcontroller IC2 400 is to convert numerical data received on serial Rx pin 520 into three independent high frequency square waves of uniform frequency but independent duty cycles on signal output pins 434, 454 and 474. The Figure 2 representation of microcontroller IC2 400 is partially stylized, in that persons of skill in the art will appreciate that certain of the twenty-eight standard pins have been omitted or combined for greatest clarity.

Microcontroller IC2 400 is powered through pin 450, which is coupled to a 5 Volt source of DC power 700. Source 700 is preferably driven from supply 300 through a coupling (not shown) that includes a voltage regulator (not shown). An exemplary voltage regulator is the LM340 3-terminal positive regulator, available from the National Semiconductor Corporation, Santa Clara, California. The teachings of the LM340 datasheet are hereby incorporated by reference. Those of skill in the art will appreciate that most microcontrollers, and many other independently powered digital integrated circuits, are rated for no more than a 5 Volt power source. The clock frequency of microcontroller IC2 400 is set by crystal 480, coupled through appropriate pins. Pin 490 is the microcontroller IC2 400 ground reference.

Switch 600 is a twelve position dip switch that may be alterably and mechanically set to uniquely identify the microcontroller IC2 400. When individual ones of the twelve mechanical switches within dip switch 600 are closed, a path is generated from corresponding pins 650 on microcontroller IC2 400 to ground 690.

Twelve switches create 2<sup>12</sup> possible settings, allowing any microcontroller IC2 400 to take on one of 4096 different IDs, or addresses. In the preferred embodiment, only nine switches are actually used because the DMX-512 protocol, discussed below, is employed.

5           Once switch 600 is set, microcontroller IC2 400 "knows" its unique address ("who am I"), and "listens" on serial line 520 for a data stream specifically addressed to it. A high speed network protocol, preferably a DMX protocol, is used to address network data to each individually addressed microcontroller IC2 400 from a central network controller (not shown). The DMX protocol is described in a United States  
10 Theatre Technology, Inc. publication entitled "DMX512/1990 Digital Data Transmission Standard for Dimmers and Controllers," incorporated herein by reference. Basically, in the network protocol used herein, a central controller (not shown) creates a stream of network data consisting of sequential data packets. Each packet first contains a header, which is checked for conformance to the  
15 standard and discarded, followed by a stream of sequential bytes representing data for sequentially addressed devices. For instance, if the data packet is intended for light number fifteen, then fourteen bytes from the data stream will be discarded, and the device will save byte number fifteen. If as in the preferred embodiment, more than one byte is needed, then the address is considered to be a starting address, and more  
20 than one byte is saved and utilized. Each byte corresponds to a decimal number 0 to 255, linearly representing the desired intensity from Off to Full. (For simplicity, details of the data packets such as headers and stop bits are omitted from this description, and will be well appreciated by those of skill in the art.) This way, each of the three LED colors is assigned a discrete intensity value between 0 and 255.  
25 These respective intensity values are stored in respective registers within the memory of microcontroller IC2 400 (not shown). Once the central controller exhausts all data packets, it starts over in a continuous refresh cycle. The refresh cycle is define by the standard to be a minimum of 1196 microseconds, and a maximum of 1 second.

30           Microcontroller IC2 400 is programmed continually to "listen" for its data stream. When microcontroller IC2 400 is "listening," but before it detects a data

packet intended for it, it is running a routine designed to create the square wave signal outputs on pins 434, 454 and 474. The values in the color registers determine the duty cycle of the square wave. Since each register can take on a value from 0 to 255, these values create 256 possible different duty cycles in a linear range from 0% to 100%. Since the square wave frequency is uniform and determined by the program running in the microcontroller IC2 400, these different discrete duty cycles represent variations in the width of the square wave pulses. This is known as pulse width modulation (PWM).

The PWM interrupt routine is implemented using a simple counter, incrementing from 0 to 255 in a cycle during each period of the square wave output on pins 434, 454 and 474. When the counter rolls over to zero, all three signals are set high. Once the counter equals the register value, signal output is changed to low. When microcontroller IC2 400 receives new data, it freezes the counter, copies the new data to the working registers, compares the new register values with the current count and updates the output pins accordingly, and then restarts the counter exactly where it left off. Thus, intensity values may be updated in the middle of the PWM cycle. Freezing the counter and simultaneously updating the signal outputs has at least two advantages. First, it allows each lighting unit to quickly pulse/strobe as a strobe light does. Such strobing happens when the central controller sends network data having high intensity values alternately with network data having zero intensity values at a rapid rate. If one restarted the counter without first updating the signal outputs, then the human eye would be able to perceive the staggered deactivation of each individual color LED that is set at a different pulse width. This feature is not of concern in incandescent lights because of the integrating effect associated with the heating and cooling cycle of the illumination element. LEDs, unlike incandescent elements, activate and deactivate essentially instantaneously in the present application. The second advantage is that one can "dim" the LEDs without the flickering that would otherwise occur if the counter were reset to zero. The central controller can send a continuous dimming signal when it creates a sequence of intensity values representing a uniform and proportional decrease in light intensity for

each color LED. If one did not update the output signals before restarting the counter, there is a possibility that a single color LED will go through nearly two cycles without experiencing the zero current state of its duty cycle. For instance, assume the red register is set at 4 and the counter is set at 3 when it is frozen. Here, the counter is frozen just before the "offpart" of the PWM cycle is to occur for the red LEDs. Now assume that the network data changes the value in the red register from 4 to 2 and the counter is restarted without deactivating the output signal. Even though the counter is greater than the intensity value in the red register, the output state is still "on", meaning that maximum current is still flowing through the red LEDs. Meanwhile, the blue and green LEDs will probably turn off at their appropriate times in the PWM cycle. This would be perceived by the human eye as a red flicker in the course of dimming the color intensities. Freezing the counter and updating the output for the rest of the PWM cycle overcomes these disadvantages, ensuring the flicker does not occur.

The network interface for microcontroller IC2 400 will now be described. Jacks 800 and 900 are standard RJ-8 network jacks. Jack 800 is used as an input jack, and is shown for simplicity as having only three inputs: signal inputs 860, 870 and ground 850. Network data enters jack 800 and passes through signal inputs 860 and 870. These signal inputs are then coupled to IC3 500, which is an RS-485/RS-422 differential bus repeater of the standard type, preferably a DS96177 from the National Semiconductor Corporation, Santa Clara, California. The teachings of the DS96177 datasheet are hereby incorporated by reference. The signal inputs 860, 870 enter IC3 500 at pins 560, 570. The data signal is passed through from pin 510 to pin 520 on microcontroller IC2 400. The same data signal is then returned from pin 540 on IC2 400 to pin 530 on IC3 500. Jack 900 is used as an output jack and is shown for simplicity as having only five outputs: signal outputs 960, 970, 980, 990 and ground 950. Outputs 960 and 970 are split directly from input lines 860 and 870, respectively. Outputs 980 and 990 come directly from IC3 500 pins 580 and 590, respectively. It will be appreciated that the foregoing assembly enables two network nodes to be connected for receiving the network data. Thus, a network may be

constructed as a daisy chain, if only single nodes are strung together, or as a binary tree, if two nodes are attached to the output of each single node.

From the foregoing description, one can see that an addressable network of LED illumination or display units can be constructed from a collection of power modules each connected to a respective light module. As long as at least two primary color LEDs are used, any illumination or display color may be generated simply by preselecting the light intensity that each color LED emits. Further, each color LED can emit light at any of 255 different intensities, depending on the duty cycle of PWM square wave, with a frill intensity pulse generated by passing maximum current through the LED. Further still, the maximum intensity can be conveniently programmed simply by adjusting the ceiling for the maximum allowable current using programming resistances for the current regulators residing on the light module. Light modules of different maximum current ratings may thereby be conveniently interchanged.

The foregoing embodiment may reside in any number of different housings. A preferred housing for an illumination unit is described. Turning now to Figure 3, there is shown an exploded view of an illumination unit of the present invention comprising a substantially cylindrical body section 10, a light module 20, a conductive sleeve 30, a power module 40, a second conductive sleeve 50, and an enclosure plate 60. It is to be assumed here that the light module 20 and the power module 40 contain the electrical structure and software of light module 100 and power module 200, described above. Screws 62, 64, 66, 68 allow the entire apparatus to be mechanically connected. Body section 10, conductive sleeves 30 and 50 and enclosure plate 60 are preferably made from a material that conducts heat, most preferably aluminum. Body , section 10 has an open end, a reflective interior portion and an illumination end, to which module 20 is mechanically affixed. Light module 20 is disk shaped and has two sides. The illumination side (not shown) comprises a plurality of LEDs of different primary colors. The connection side holds an electrical connector male pin assembly 22. Both the illumination side and the connection side are coated with aluminum surfaces to better allow the conduction of

heat outward from the plurality of LEDs to the body section 10. Likewise, power module 40 is disk shaped and has every available surface covered with aluminum for the same reason. Power module 40 has a connection side holding an electrical connector female pin assembly 44 adapted to fit the pins from assembly 22. Power module 40 has a power terminal side holding a terminal 42 for connection to a source of DC power. Any standard AC or DC jack may be used, as appropriate.

Interposed between light module 20 and power module 40 is a conductive aluminum sleeve 30, which substantially encloses the space between modules 20 and 40. As shown, a disk-shaped enclosure plate 60 and screws 62, 64, 66 and 68 seal all of the components together, and conductive sleeve 50 is thus interposed between enclosure plate 60 and power module 40. Once sealed together as a unit, the illumination apparatus may be connected to a data network as described above and mounted in any convenient manner to illuminate an area. In operation, preferably a light diffusing means will be inserted in body section 10 to ensure that the LEDs on light module 20 appear to emit a single uniform frequency of light.

From the foregoing, it will be appreciated that PWM current control of LEDs to produce multiple colors may be incorporated into countless environments, with or without networks. For instance, Figure 8 shows a hand-held flashlight can be made to shine any conceivable color using an LED assembly of the present invention. The flashlight contains an external adjustment means 5, that may be for instance a set of three potentiometers coupled to an appropriately programmed microcontroller through respective A/D conversion means 15. Each potentiometer would control the current duty cycle, and thus the illumination intensity, of an individual color LED on LED board 25. With three settings each capable of generating a different byte from 0 to 255, a computer-controlled flashlight may generate twenty-four bit color. Of course, three individual potentiometers can be incorporated into a single device, such as a track ball or joystick, so as to be operable as a single adjuster. Further, it is not necessary that the adjustment means must be a potentiometer. For instance, a capacitive or resistive thumb plate may also be used to program the two or three registers necessary to set the color. A non-hand held embodiment of the present

invention may be used as an underwater swimming pool light. Since the present invention can operate at relatively low voltages and low current, it is uniquely suited for safe underwater operation.

Similarly, the present invention may be used as a general indicator of any given environmental condition. Figure 9 shows the general functional block diagram for such an apparatus. Shown within Figure 9 is also an exemplary chart showing the duty cycles of the three color LEDs during an exemplary period. As one example of an environmental indicator, the power module can be coupled to an inclinometer. The inclinometer measures general angular orientation with respect to the earth's center of gravity. The inclinometer's angle signal can be converted through an A/D converter and coupled to the data inputs of the microcontroller in the power module. The microcontroller can then be programmed to assign each discrete angular orientation a different color through the use of a lookup table associating angles with LED color register values. The "color inclinometer" may be used for safety, such as in airplane cockpits, or for novelty, such as to illuminate the sails on a sailboat that sways in the water. Another indicator use is to provide an easily readable visual temperature indication. For example, a digital thermometer can be connected to provide the microcontroller a temperature reading. Each temperature will be associated with a particular set of register values, and hence a particular color output. A plurality of such "color thermometers" can be located over a large space, such as a storage freezer, to allow simple visual inspection of temperature over three dimensions.

Another use of the present invention is as a lightbulb. Using appropriate rectifier and voltage transformation means, the entire power and light modules may be placed in an Edison-mount (screw-type) lightbulb housing. Each bulb can be programmed with particular register values to deliver a particular color bulb, including white. The current regulator can be preprogrammed to give a desired current rating and thus preset light intensity. Naturally, the lightbulb may have a transparent or translucent section that allows the passage of light into the ambient.



While the foregoing has been a detailed description of the preferred embodiment of the invention, the claims which follow define more freely the scope of invention to which applicant is entitled. Modifications or improvements which may not come within the explicit language of the claims described in the preferred  
5 embodiments should be treated as within the scope of invention insofar as they are equivalent or otherwise consistent with the contribution over the prior art and such contribution is not to be limited to specific embodiments disclosed.

We claim:

1. Light apparatus comprising:

a power terminal;

5 at least one LED coupled to the power terminal;

a current sink coupled to the at least one LED, the current sink comprising an input responsive to an activation signal that enables flow of current through the current sink;

10 an addressable controller having an alterable address, the controller coupled to the input and having timing means for generating the activation signal for a predefined portion of a timing cycle;

the addressable controller further comprising means for receiving data corresponding to the alterable address and indicative of the predefined portion of the timing cycle.

15 2. The light apparatus of claim 1 comprising:

a second LED coupled to the power terminal and the current sink;

the current sink comprising a second input corresponding to the second LED and responsive to a second activation signal;

20 the addressable controller comprising second timing means for generating the second activation signal for a second predefined portion of the timing cycle, and further comprising second means for receiving data corresponding to the alterable address and indicative of the second predefined portion of a timing cycle.

3. The light apparatus of claim 2 wherein the at least one LED and the second LED comprise different colors.

25 4. The light apparatus of claim 1 wherein the predefined portion represents the duty cycle of a PWM signal and the timing cycle is the PWM period.

5. A modular LED illumination assembly comprising

a body portion having an open end, an illumination end, and a reflective interior portion therebetween defining a body portion axis;

a power module adapted to be mechanically attachable to the illumination end substantially along the body portion axis, the power module having a terminal for attachment to a power supply; and

5 a light module comprising a plurality of LEDs and having an electrical connector removably attachable to the power module, the light module disposed between the illumination end and the power module such that the LEDs optically communicate with the reflective interior portion;

whereby different light modules having a different plurality of LED's may be conveniently interchanged.

10 6. The assembly of claim 5, wherein the power module comprises a current regulator for controlling maximum current supplied to the plurality of LED'S, and the light module comprises means for programming the current regulator.

7. The assembly of claim 5, wherein the light module comprises a thermally conductive surface.

15 8. The assembly of claim 5, wherein the power module comprises a thermally conductive surface.

9. The assembly of claim 5, wherein the body portion is substantially cylindrical, and the power module and light module are substantially disk-shaped.

20 10. The assembly of claim 5 wherein the power module and the light module define a space therebetween and a conductive sleeve disposed between the light module and the power module substantially encloses the space.

11. The assembly of claim 5, wherein the electrical connector comprises a conductive pin assembly.

25 12. The assembly of claim 5, wherein the plurality of LED's comprises a first plurality of LED's of a first color and a second plurality of LED's of a second color.

13. The assembly of claim 12, wherein the first color and the second colors are different primary colors.

14. The assembly of claim 5, wherein the power module comprises: a current sink coupled to the plurality of LED'S, the current sink comprising an input responsive to an activation signal that enables flow of current through the current sink;

5 an addressable controller having an alterable address and coupled to the input, the addressable controller comprising timing means for generating the activation signal for a predefined portion of a timing cycle;

the addressable controller further comprising means for receiving data corresponding to the alterable address and indicative of the predefined portion of a timing cycle.

10 15. A lighting network comprising a central controller and a plurality of uniquely addressable illumination units, each unit comprising a first color LED and a second color LED; each unit further comprising:

data means for receiving from the central controller network data comprising LED intensity values addressed to an individual illumination unit and corresponding to respective ones of the first color and second color LED;

memory means for storing intensity values received from said network data corresponding to the first color LED and to the second color LED;

20 control means for generating a first pulse width modulated signal and a second pulse width modulated signal, each of the first and second signals having a duty cycle corresponding to the respective intensity values, whereby each of the first and second pulse width modulated signals is alternately in a high or a low state;

25 current switching means for applying current to the first color LED when the first pulse width modulated signal is in one of either the high or the low state, and for applying current to the second color LED when the second pulse width modulated signal is in one of either the high or the low state.

16. The network of claim 15 wherein the first color LED is a plurality of first color LEDs and the second color LED is a plurality of second color LEDs.

30 17. The network of claim 15 wherein the first color and the second color LEDs are respectively a first primary color LED and a second primary color LED.

18. The network of claim 15 wherein the unit comprises a third color LED, the intensity values addressed to an individual illumination unit further correspond to the third color LED, the control means further generates a third pulse width modulated signal having a duty cycle corresponding to the third color LED intensity value, whereby the third pulse width modulated signals is alternately in a high or a low state, and the current switching means further applies current to the third color LED when the third pulse width modulated signal is in one of either the high or the low state.

19. The network of claim 18 wherein the first color, the second color and the third color are different primary colors.

20. The network of claim 15 wherein the data means comprises a repeater adapted to electrically interconnect each unit to at least two other units to form a path for the network data.

21. The network of claim 20 wherein the repeater is adapted to electrically interconnect each unit to one network data input and to two network data outputs, whereby the network may comprise a binary tree configuration.

22. A modular LED illumination assembly comprising a power module having a terminal for attachment to a power supply; and a light module comprising a plurality of LEDs and having an electrical connector removably attachable to the power module,

the power module further comprising a current regulator for controlling maximum current supplied to the plurality of LED'S, and the light module further comprising means for programming the current regulator,

whereby different light modules having a different plurality of LED's and different light intensity ratings may be conveniently interchanged.

23. An illumination apparatus comprising:

a plurality of LEDs of at least two different colors adapted to be coupled to a power source and to a common potential reference;

a current sink interposed between the plurality of LEDs and the common potential reference, the current sink comprising at least two switches corresponding to respective current paths of the at least two different color LEDs;

control means for periodically and independently opening and closing the at least two switches at high frequency and for generating a duty cycle thereby;

programming means coupled to the control means for programming respective duty cycles for each color of the at least two different color LEDs.

24. The apparatus of claim 23 wherein the duty cycle may be varied from a minimum to a maximum, and the programming means is adapted to generate a substantially continuous range of duty cycles between the minimum and the maximum.

25. The apparatus of claim 23 wherein the programming means comprises respective potentiometers for each color of the at least two different color LEDs each having an independently adjustable setting, and the control means comprises an analog-to-digital converter for converting each independently adjustable setting into a numerical value indicative of each respective duty cycle.

26. The apparatus of claim 23 comprising a housing that substantially encloses the plurality of LEDs, the current sink, the control means and the programming means.

27. The apparatus of claim 26 wherein the housing is hand-held.

28. The apparatus of claim 27 wherein the housing comprises a compartment for containing the power source and common reference potential, and wherein the housing further comprises a lens assembly for reflecting the light emitted from the plurality of LEDs.

29. The apparatus of claim 23 wherein the programming means comprises an inclinometer, the inclinometer generating an output signal indicative of the angular orientation of the apparatus, and the control means comprises conversion means for converting the output signal into a numerical value indicative of each respective duty cycle,

whereby different angular orientations vary color and intensity of the plurality of LEDs to produce different color outputs.

30. The apparatus of claim 23 wherein the programming means comprises a transceiver for receiving an electromagnetic signal containing data that includes a numerical value indicative of each respective duty cycle.

31. The apparatus of claim 23 wherein the programming means comprises a transceiver for receiving an infrared signal containing data that includes a numerical value indicative of each respective duty cycle.

32. An Edison-mount lightbulb comprising:  
voltage regulating means for converting an AC potential into a DC power source;

a plurality of LEDs of at least two different colors adapted to be coupled to the DC power source and to a common potential reference;

a light-transmitting enclosure surrounding the plurality of LEDs;

a current sink interposed between the plurality of LEDs and the common potential reference, the current sink comprising at least two switches corresponding to respective current paths of the at least two different color LEDs;

control means for periodically and independently opening and closing the at least two switches at high frequency and for generating a duty cycle thereby.

33. The lightbulb of claim 32 wherein the duty cycle is predefined and uniform, whereby the lightbulb permanently generates a single unalterable color of light.

34. A method for controlling current through an LED assembly comprising the steps of:

providing a memory location;

placing a numerical value in the memory location indicative of the duty cycle of a pulse width modulated waveform;

closing an LED circuit between supply and ground when the waveform is in one state,

and opening the LED circuit when the waveform is in the other state;

changing the numerical value in the memory location upon receipt of a new numerical value over a computer network.

35. The method of claim 34 comprising the steps of:

5 providing a counter, wherein the pulse width modulated waveform is in the one state when the counter is below the numerical value;

stopping the counter, updating the waveform state, changing the numerical value in the, memory location, and restarting the counter, all upon receipt of a new numerical value over a computer network.

36. An illumination system, comprising:

10 a plurality of light modules; and

a pulse width modulated current control, wherein each light module is addressable and capable of receiving illumination color information.

37. An illumination system, comprising:

15 a plurality of light modules; and

a current control, wherein each light module is addressable and capable of receiving illumination color information on a computer lighting network.

38. The illumination system of claim 37, wherein the current control is a pulse width modulated current control.

20 39. An illumination system, comprising:

a network for delivery of data;

a plurality of uniquely addressable light emitting diodes, connected to the network; and

25 a microprocessor, for selectively controlling the light emitting diodes to provide a desired illumination condition.

40. The illumination system of claim 39, wherein selectively controlling the light emitting diodes includes providing a pulse width modulated current control.



41. The illumination system of claim 39, further comprising:  
a computer program for controlling the microprocessor.

42. The illumination system of claim 41, further comprising:

a sensor, for sensing a condition, wherein the sensor provides an  
5 input to the computer program for controlling microprocessor, whereby the  
illumination is controlled in response to the condition.

43. The illumination system of claim 42, further comprising:

an object to be illuminated, wherein the illumination condition is  
10 responsive to a condition of the object.

10

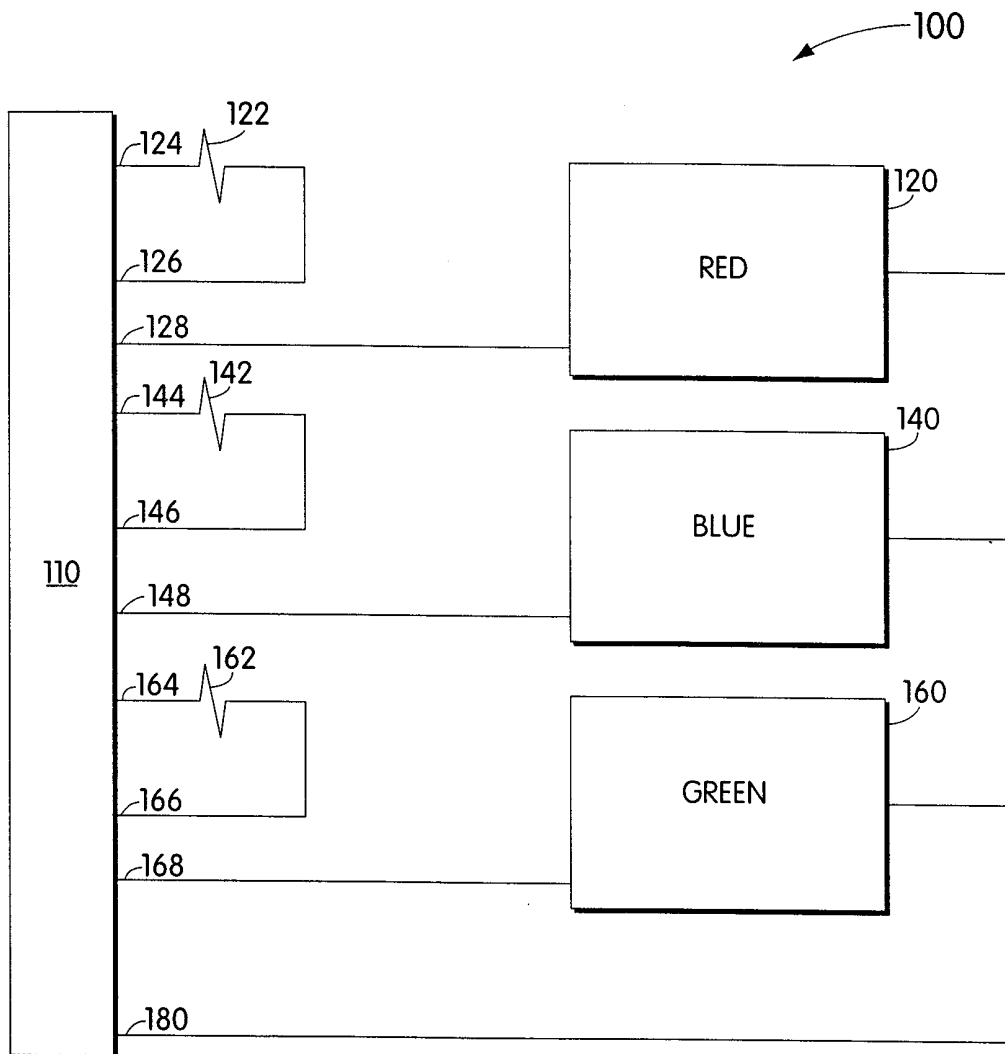

Fig. 1

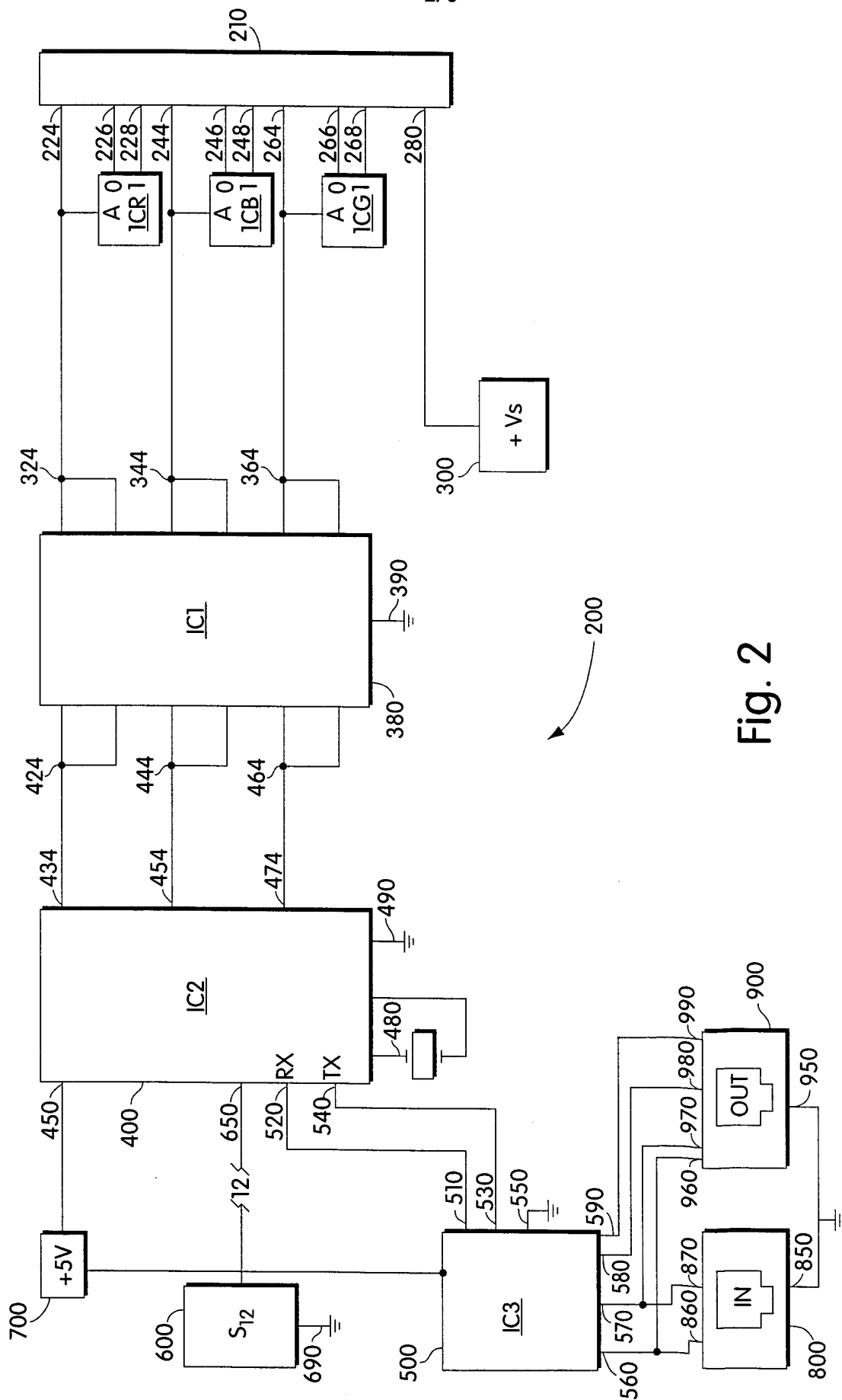

Fig. 2

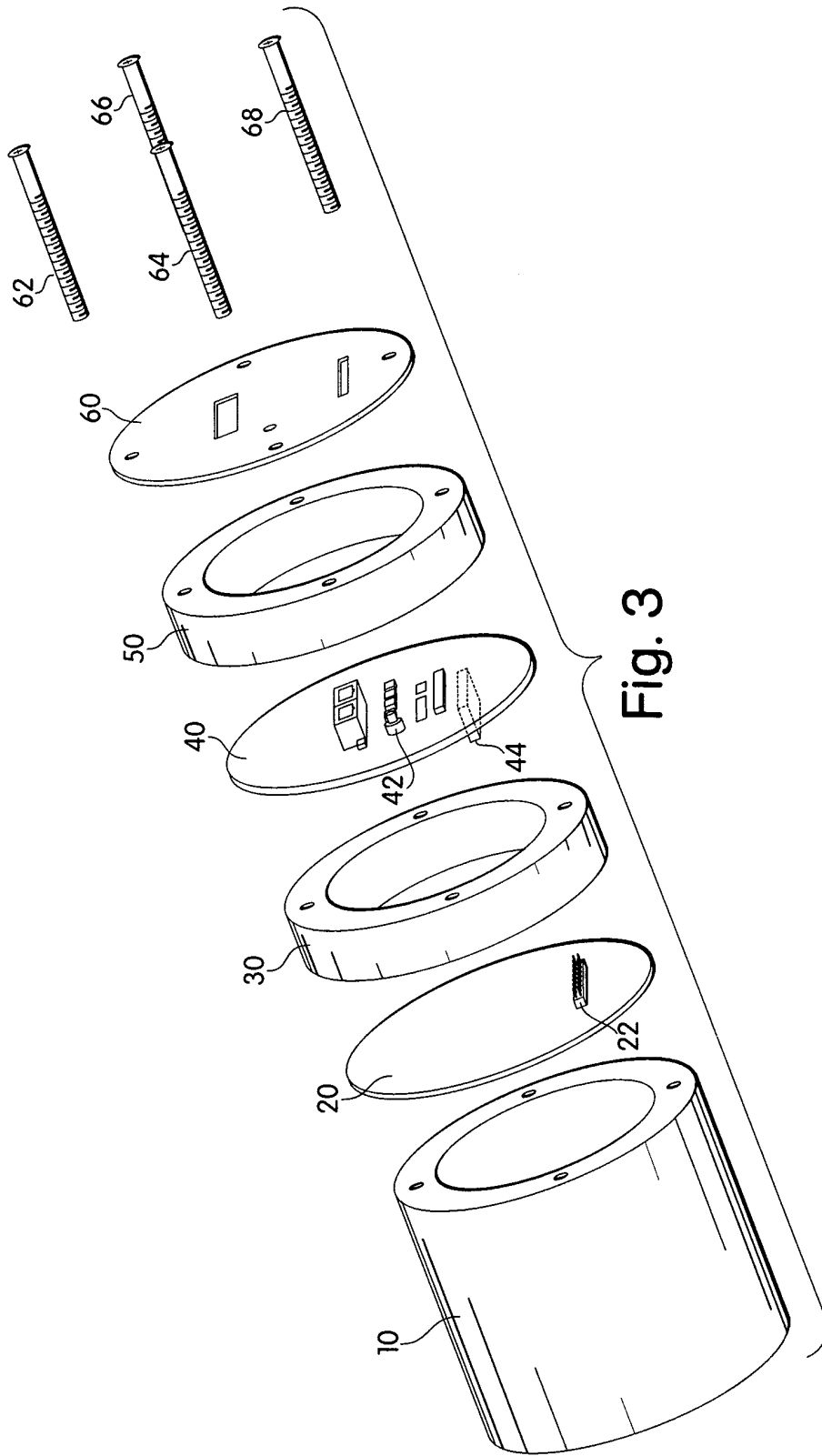

Fig. 3

4/6

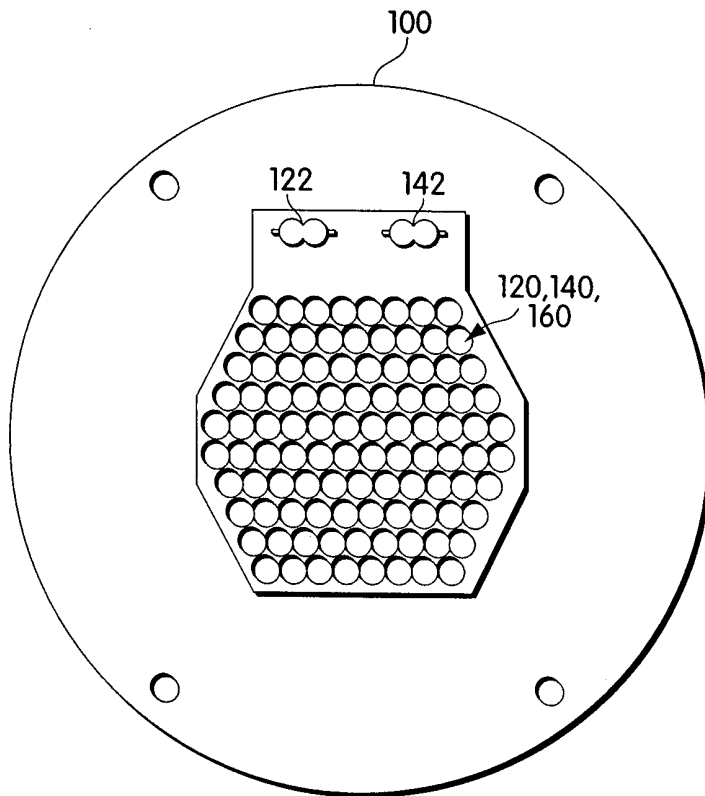

Fig. 4

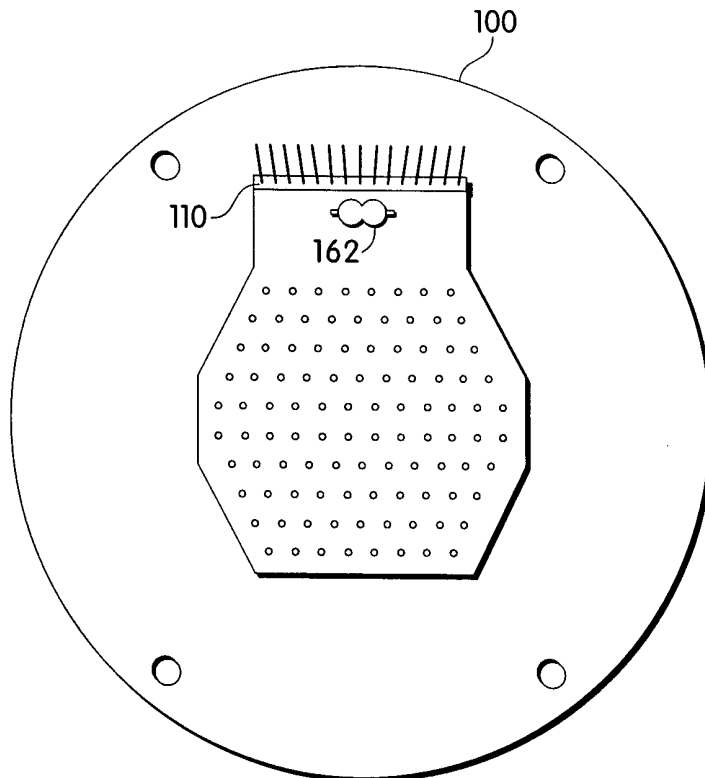

Fig. 5

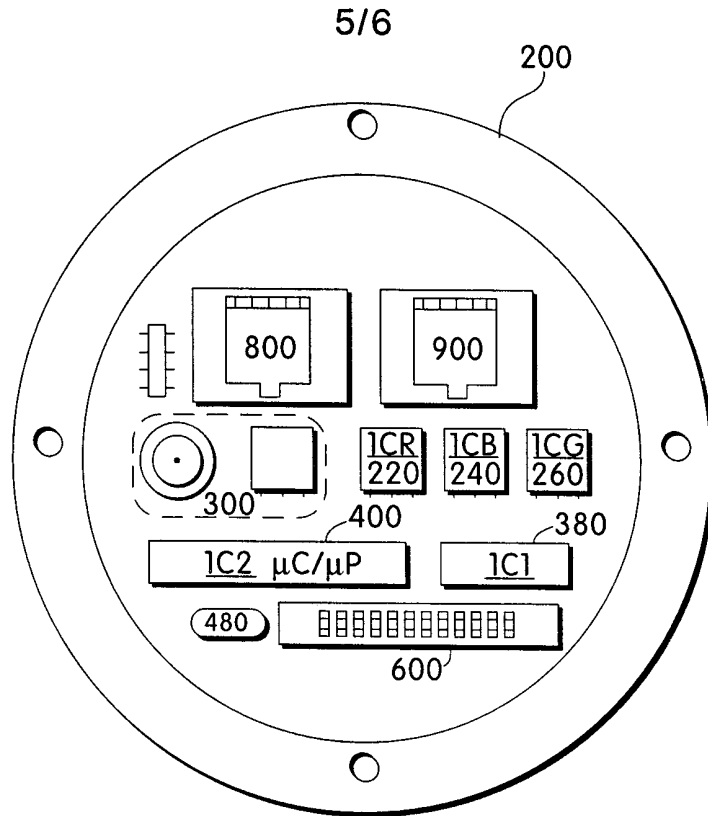

Fig. 6

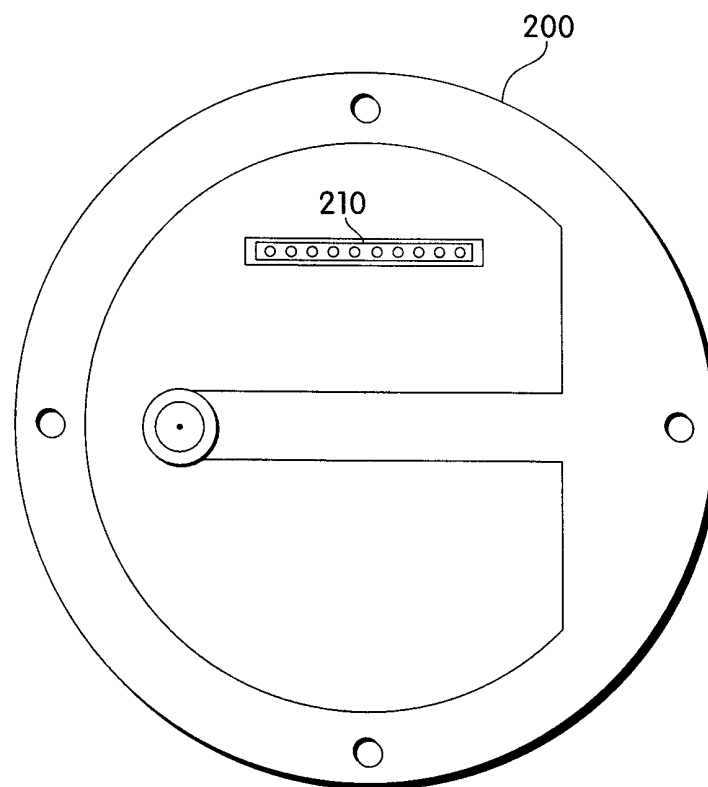

Fig. 7

SUBSTITUTE SHEET (RULE 26)

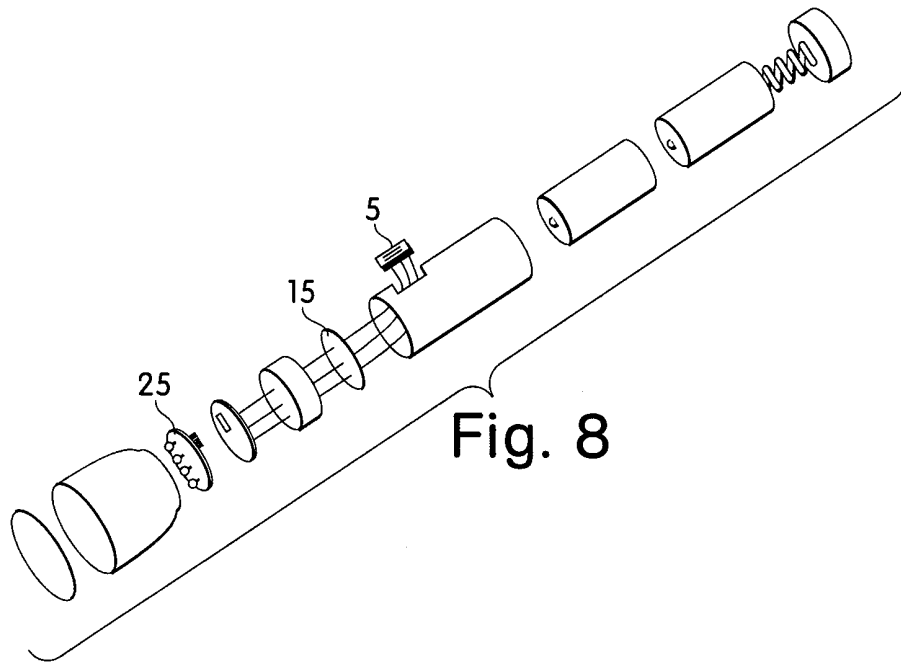

Fig. 8

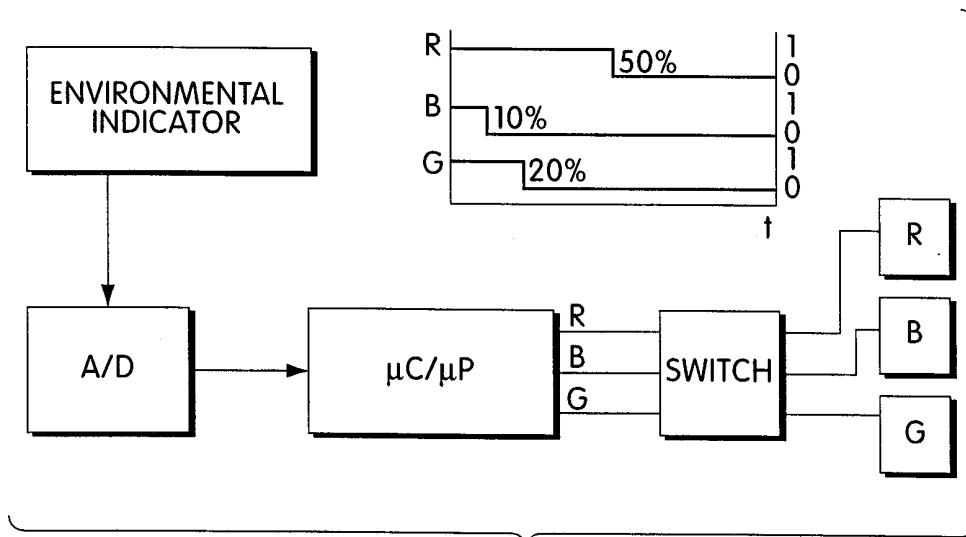

Fig. 9

# INTERNATIONAL SEARCH REPORT

Inter      nal Application No  
PCT/US 98/17702

**A. CLASSIFICATION OF SUBJECT MATTER**  
IPC 6   G09G3/32       H05B37/02

According to International Patent Classification (IPC) or to both national classification and IPC

**B. FIELDS SEARCHED**

Minimum documentation searched (classification system followed by classification symbols)  
IPC 6   G09G   H05B

Documentation searched other than minimum documentation to the extent that such documents are included in the fields searched

Electronic data base consulted during the international search (name of data base and, where practical, search terms used)

**C. DOCUMENTS CONSIDERED TO BE RELEVANT**

Category °	Citation of document, with indication, where appropriate, of the relevant passages	Relevant to claim No.
X A  A  A	<p>US 4 887 074 A (SIMON MICHAEL ET AL) 12 December 1989 see abstract; figures 1-5  see column 2, line 29 - column 3, line 65 see column 5, line 27 - column 7, line 25 ---</p> <p>US 5 410 328 A (YOKSZA DAVID R ET AL) 25 April 1995 see abstract; figures 1-9 see column 3, line 47 - column 4, line 66 ---</p> <p>EP 0 752 632 A (VARI LITE INC) 8 January 1997 see abstract; figures 1,2 see column 6, line 55 - column 8, line 30 ---</p> <p style="text-align: center;">-/--</p>	<p>23  1-3,7, 12-17  5,11-13, 15-17  1,15,20, 21,38,41</p>

Further documents are listed in the continuation of box C.

Patent family members are listed in annex.

° Special categories of cited documents :

- "A" document defining the general state of the art which is not considered to be of particular relevance
- "E" earlier document but published on or after the international filing date
- "L" document which may throw doubts on priority claim(s) or which is cited to establish the publication date of another citation or other special reason (as specified)
- "O" document referring to an oral disclosure, use, exhibition or other means
- "P" document published prior to the international filing date but later than the priority date claimed

- "T" later document published after the international filing date or priority date and not in conflict with the application but cited to understand the principle or theory underlying the invention
- "X" document of particular relevance; the claimed invention cannot be considered novel or cannot be considered to involve an inventive step when the document is taken alone
- "Y" document of particular relevance; the claimed invention cannot be considered to involve an inventive step when the document is combined with one or more other such documents, such combination being obvious to a person skilled in the art.
- "&" document member of the same patent family

Date of the actual completion of the international search

23 December 1998

Date of mailing of the international search report

04/01/1999

Name and mailing address of the ISA

European Patent Office, P.B. 5818 Patentlaan 2  
NL - 2280 HV Rijswijk  
Tel. (+31-70) 340-2040, Tx. 31 651 epo nl,  
Fax: (+31-70) 340-3016

Authorized officer

Van Roost, L



INTERNATIONAL SEARCH REPORT

International Application No

PCT/US 98/17702

C.(Continuation) DOCUMENTS CONSIDERED TO BE RELEVANT

Category °	Citation of document, with indication, where appropriate, of the relevant passages	Relevant to claim No.
A	FR 2 640 791 A (CHENG ERIC) 22 June 1990  see abstract; figures 1-9 see page 2, line 20 - page 2, line 25 see page 9, line 11 - page 12, line 11 ----	1-3, 5, 15, 39-41
A	PATENT ABSTRACTS OF JAPAN vol. 018, no. 273 (P-1742), 24 May 1994 & JP 06 043830 A (NEC CORP), 18 February 1994 see abstract ----	1, 2, 4, 15
A	US 5 420 482 A (PHARES LOUIS A) 30 May 1995 cited in the application see abstract; figures 1-10 -----	1-43

# INTERNATIONAL SEARCH REPORT

...formation on patent family members

Inter- national Application No

PCT/US 98/17702

Patent document cited in search report	A	Publication date	Patent family member(s)	Publication date
US 4887074	A	12-12-1989	NONE	
<hr style="border-top: 1px dashed black;"/>				
US 5410328	A	25-04-1995	NONE	
<hr style="border-top: 1px dashed black;"/>				
EP 0752632	A	08-01-1997	US 5769527 A	23-06-1998
			AU 699094 B	19-11-1998
			AU 6267996 A	30-12-1996
			CA 2178432 A	08-12-1996
			JP 9320766 A	12-12-1997
			WO 9641098 A	19-12-1996
<hr style="border-top: 1px dashed black;"/>				
FR 2640791	A	22-06-1990	NONE	
<hr style="border-top: 1px dashed black;"/>				
US 5420482	A	30-05-1995	AU 6034394 A	29-08-1994
			CA 2155858 A	18-08-1994
			WO 9418809 A	18-08-1994
<hr style="border-top: 1px dashed black;"/>				