

(12) INTERNATIONAL APPLICATION PUBLISHED UNDER THE PATENT COOPERATION TREATY (PCT)

(19) World Intellectual Property
Organization
International Bureau

(43) International Publication Date
17 June 2021 (17.06.2021)



(10) International Publication Number
WO 2021/115543 A1

(51) International Patent Classification:

G01M 5/00 (2006.01) G01M 7/02 (2006.01)

(21) International Application Number:

PCT/DK2020/050356

(22) International Filing Date:

11 December 2020 (11.12.2020)

(25) Filing Language:

English

(26) Publication Language:

English

(30) Priority Data:

PA 2019 70768 12 December 2019 (12.12.2019) DK

(71) Applicant: VESTAS WIND SYSTEMS A/S [DK/DK];
Hedeager 42, 8200 Aarhus N (DK).

(72) Inventor: DANN, Michael; 8B Cherry tree Road, Watford
Greater London WD24 6SB (GB).

(81) Designated States (unless otherwise indicated, for every kind of national protection available): AE, AG, AL, AM, AO, AT, AU, AZ, BA, BB, BG, BH, BN, BR, BW, BY, BZ, CA, CH, CL, CN, CO, CR, CU, CZ, DE, DJ, DK, DM, DO, DZ, EC, EE, EG, ES, FI, GB, GD, GE, GH, GM, GT, HN, HR, HU, ID, IL, IN, IR, IS, IT, JO, JP, KE, KG, KH, KN, KP, KR, KW, KZ, LA, LC, LK, LR, LS, LU, LY, MA, MD, ME, MG, MK, MN, MW, MX, MY, MZ, NA, NG, NI, NO, NZ, OM, PA, PE, PG, PH, PL, PT, QA, RO, RS, RU, RW,

SA, SC, SD, SE, SG, SK, SL, ST, SV, SY, TH, TJ, TM, TN, TR, TT, TZ, UA, UG, US, UZ, VC, VN, WS, ZA, ZM, ZW.

(84) Designated States (unless otherwise indicated, for every kind of regional protection available): ARIPO (BW, GH, GM, KE, LR, LS, MW, MZ, NA, RW, SD, SL, ST, SZ, TZ, UG, ZM, ZW), Eurasian (AM, AZ, BY, KG, KZ, RU, TJ, TM), European (AL, AT, BE, BG, CH, CY, CZ, DE, DK, EE, ES, FI, FR, GB, GR, HR, HU, IE, IS, IT, LT, LU, LV, MC, MK, MT, NL, NO, PL, PT, RO, RS, SE, SI, SK, SM, TR), OAPI (BF, BJ, CF, CG, CI, CM, GA, GN, GQ, GW, KM, ML, MR, NE, SN, TD, TG).

Published:

— with international search report (Art. 21(3))

(54) Title: BLADE PORTION MOUNTING STRUCTURE

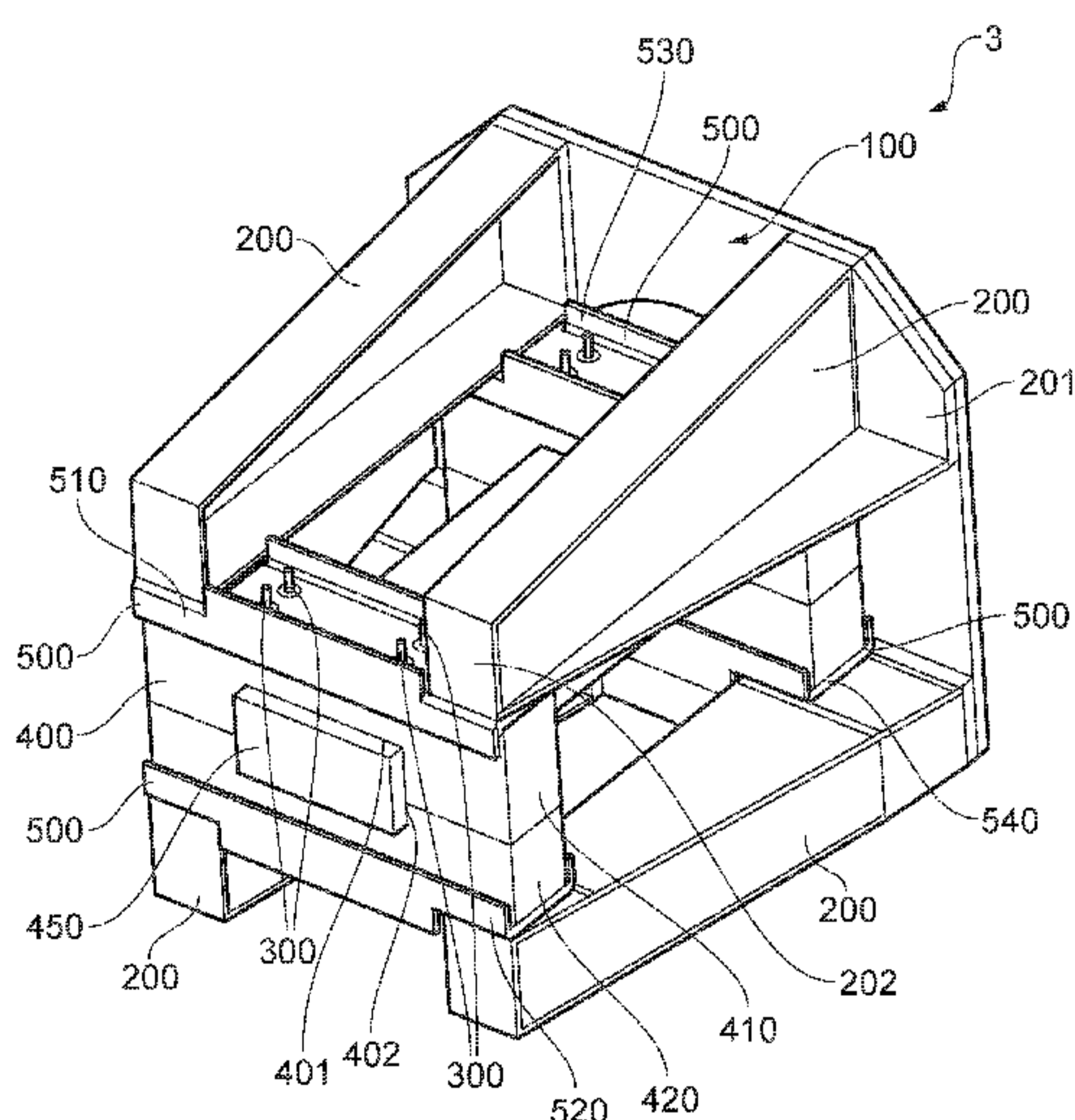

FIG. 3

(57) Abstract: The present invention relates to a mounting structure for securing a wind turbine blade portion to a testing apparatus for mechanical testing, comprising: a base component; at least one cantilever arm attached to, and extending from, the base component; and at least one tie rod configured to extend through the blade portion. The mounting structure is configured such that a root end of the blade portion can be secured in place at the cantilever arm by a clamping force exerted by the at least one tie rod. Another aspect of the invention relates to a method of installing a blade portion into the testing apparatus.

WO 2021/115543 A1

BLADE PORTION MOUNTING STRUCTURE

FIELD OF THE INVENTION

- 5 The present invention relates to a mounting structure for securing a wind turbine blade portion to a testing apparatus for mechanical testing.

BACKGROUND OF THE INVENTION

- 10 A wind turbine converts kinetic energy of the wind into electrical energy. A generator converts the wind energy captured by a rotor having one or more rotor blades into electrical energy that is usually supplied to a utility grid. The generator is housed in a nacelle together with the various components required to operate and optimize the performance of the wind turbine. A tower supports the load presented by the nacelle
15 and the rotor. In a horizontal axis wind turbine (HAWT) the rotor blades extend radially outwardly from a central hub which rotates about a longitudinal axis aligned generally horizontally. In operation, the blades are configured to interact with the passing air flow to produce lift that causes the rotor to rotate within a plane substantially perpendicular to the direction of the wind.

20

- A conventional rotor blade is made from an outer shell and one or more inner spars in a hollow space bounded by the outer shell. The spar serves to transfer loads from the rotating blade to the hub of the wind turbine. Such loads include tensile and compressive loads directed along the length of the blade arising from the circular
25 motion of the blade and loads arising from the wind which are directed along the thickness of the blade, i.e. from the windward side of the blade to the leeward side. The spar may typically have a hollow tubular section, e.g. generally rectangular hollow tubular section, or a beam section, e.g. I-beam, C-beam, H-beam, Y-beam, X-beam, etc., with one or more shear webs extending between spar caps. The spar caps may
30 incorporated into the outer shell or may be attached to the outer shell.

- The spar cap may include pultruded fibrous strips of material. Pultrusion is a continuous process similar to extrusion, wherein fibres are pulled through a supply of liquid resin and then heated in an open chamber where the resin is cured. The resulting cured
35 fibrous material is of constant cross section but, since the process is continuous, the

material once formed may be cut to any arbitrary length. WO 2013/087078, which is incorporated herein by reference, describes a wind turbine blade with an elongate reinforcing structure comprising a stack of pultruded fibrous composite strips.

5 The general trend in the wind turbine industry over the past several years has been for wind turbine blades to be made longer. The longer the blades, the larger the rotor and the more wind energy can be captured, improving the efficiency of an individual wind turbine.

10 It is known to construct wind turbine blades using separable spanwise blade portions, which are joined together in order to facilitate transport of large wind turbine blades. For example, applicant's co-pending PCT application no. PCT/DK2017/050441, which is incorporated herein by reference, describes such a 'split blade' for a wind turbine.

15 SUMMARY OF THE INVENTION

A first aspect of the invention provides a mounting structure for securing a wind turbine blade portion to a testing apparatus for mechanical testing, the mounting structure comprising:

- 20 a base component;
at least one cantilever arm attached to, and extending from, the base component; and
at least one tie rod configured to extend through the blade portion;
- wherein the mounting structure is configured such that a root end of the blade portion
25 can be secured in place by the at least one cantilever arm by a clamping force exerted by the at least one tie rod.

The invention is advantageous in that it provides a mechanism for reliably determining and testing the mechanical properties of a blade portion of a multiple portion wind
30 turbine blade or 'split blade'. The invention is advantageous in that the properties determined through use of the mounting structure can give an accurate indication of how the tested portion of wind turbine blade could perform in use when installed on a wind turbine. The invention is also advantageous in that a blade portion can be mounted for testing without using an integral joining function of the blade portion. The
35 mounting structure is further advantageous in that it allows any blade portion of any

shape and/or dimensions to be mounted to an existing test assembly via the mounting structure to enable the blade portion to be subject to test procedures.

The cantilever arm may be at least two cantilever arms, or may be four cantilever arms.
5 Where at least two cantilever arms are provided, the blade portion can be secured in place between the cantilever arms by a clamping force exerted by the at least one tie rod.

The mounting structure may comprise a profile insert. The profile insert may have at
10 least one contacting wall, and the contacting wall may define an opening. The opening may be configured to receive at least part of a blade portion. The contacting wall may be shaped so as to align with and contact the blade portion.

The profile insert may comprise at least two separable parts. Each part may have a
15 contacting wall. The contacting walls may each contact opposing sides of a blade portion when a blade portion is installed in the mounting structure.

The profile insert(s) advantageously enable any blade portion of any shape to be
clamped into the mounting structure as the profile insert(s) can be shaped to
20 substantially match the shape and contours of a given blade portion.

The mounting structure may further comprise at least one inner profile, configured to be received in the wind turbine blade portion.

25 The mounting structure may comprise a pair of cross-beams extending in a transverse direction across the cantilever arm. Where at least two cantilever arms are provided, the mounting structure may comprise a pair of cross-beams extending in a transverse direction between the cantilever arms.

30 The mounting structure may comprise at least two pairs of cross-beams. One pair may be spaced apart from another pair along the cantilever arm or arms in the direction of extension of the cantilever arm or arms.

35 One or more of the cross-beams may be adjustable relative to another of the cross-beams.

At least one of the cross-beams may form a recess. The recess may receive at least part of the profile insert.

- 5 A root end of at least one of the cantilever arms, or of the at least one cantilever arm, may be fixed in position, and this may be to the base component.

A root end of at least one of the cantilever arms, or of the at least one cantilever arm, may be adjustably connected to the base component. This advantageously enables
10 the mounting structure to accommodate blade portions of different dimensions.

The adjustable connection may comprise an elongate aperture, and may comprise a pin. The cantilever arm may be translatable along the elongate aperture when in an installed state. The pin may be a threaded stud, or a bolt.

15

The elongate aperture may extend in the base component in a radial direction, and/or a transverse direction defined by the blade portion cross-section when the blade portion is fully installed into the mounting structure. The radial direction may extend radially from a central point or axis of the blade portion cross-section. The transverse
20 direction may be any direction which is not a radial direction, but may be parallel to or aligned with a radial direction.

The base component may be a base plate. The base plate may define a central aperture, which may provide access from a rear side of the mounting structure to the
25 blade portion.

According to a second aspect of the present invention there is provided a wind turbine blade portion test assembly, comprising the mounting structure of the first aspect, and a wind turbine blade portion.

30

Therefore, the mounting structure as described with any of the optional features provided above may be provided as part of a wind turbine blade portion test assembly.

The or each tie rod may extend to one side of at least one spar cap of the wind turbine
35 blade portion. Preferably the tie rod does not extend through the spar cap.

The or each tie rod may extend along a side of a shear web of the wind turbine blade portion. The positioning of the tie rod(s) to one side of the at least one spar cap and/or along a side of a shear web of the blade portion advantageously enables substantially all of the load from the clamping of the blade portion to be transmitted through the support structures (e.g. spar cap, shear web, pultrusions) of the blade portions so that the surface of the blade portions effectively receives negligible loads from clamping of the blade portion in the mounting structure.

10 A root end face of the wind turbine blade portion may project from the one or more tie rods towards the base component. A tip end of the wind turbine blade portion may project from the one or more tie rods away from the mounting structure.

15 The root end face of the wind turbine blade portion may not be directly attached to the mounting structure.

The wind turbine blade portion test assembly may further comprise a ring bearing. The ring bearing may be configured to allow rotation of the blade portion, preferably through 360°. The ring bearing may be fastened to the base component.

20

A third aspect of the invention provides a method of installing a blade portion into a testing apparatus, comprising:

25 providing a blade portion,
providing the mounting structure of the first aspect,
locating a root end of the blade portion at the at least one cantilever arm, and
securing the cantilever arm so as to exert a clamping force from the cantilever arm on the blade portion.

30 The step of securing the cantilever arm so as to exert a clamping force from the cantilever arm on the blade portion may comprise securing the at least one tie rods so as to exert a clamping force from the cantilever arms on the blade portion.

The step of locating a root end of the blade portion at the at least one cantilever arm, may comprise locating a root end of the blade portion within the mounting structure.

35 The step of locating a root end of the blade portion at the at least one cantilever arm,

may comprise locating a root end of the blade portion between at least two cantilever arms.

This aspect of the invention benefits from the same advantages as the first aspect of the invention, at least one of which is identified above.

The blade portion may be a tip portion or an intermediate portion of a multiple-portion blade.

10 BRIEF DESCRIPTION OF THE DRAWINGS

Embodiments of the invention will now be described with reference to the accompanying drawings, in which:

15 Figure 1 shows a wind turbine;

Figure 2 shows a wind turbine blade comprising separable wind turbine blade portions;

Figure 3 shows a mounting structure;

20

Figure 4 shows a cross-section through a wind turbine blade portion test assembly;

Figure 5 shows a base component;

25 Figure 6 shows a cross-beam; and

Figure 7 shows a wind turbine blade portion test assembly.

DETAILED DESCRIPTION OF EMBODIMENT(S)

30

In this specification, terms such as leading edge, trailing edge, pressure surface, suction surface, thickness, chord and planform are used. While these terms are well known and understood to a person skilled in the art, definitions are given below for the avoidance of doubt.

35

The term “leading edge” is used to refer to an edge of the blade which will be at the front of the blade as the blade rotates in the normal rotation direction of the wind turbine rotor.

- 5 The term “trailing edge” is used to refer to an edge of a wind turbine blade which will be at the back of the blade as the blade rotates in the normal rotation direction of the wind turbine rotor.

10 The chord of a blade is the straight line distance from the leading edge to the trailing edge in a given cross section perpendicular to the blade spanwise direction.

A pressure surface (or windward surface) of a wind turbine blade is a surface between the leading edge and the trailing edge, which, when in use, has a higher pressure than a suction surface of the blade.

15

A suction surface (or leeward surface) of a wind turbine blade is a surface between the leading edge and the trailing edge, which will have a lower pressure acting upon it than that of a pressure surface, when in use.

- 20 The thickness of a wind turbine blade is measured perpendicularly to the chord of the blade and is the greatest distance between the pressure surface and the suction surface in a given cross section perpendicular to the blade spanwise direction.

25 The term “spanwise” is used to refer to a direction from a root end of a wind turbine blade to a tip end of the blade, or vice versa. When a wind turbine blade is mounted on a wind turbine hub, the spanwise and radial directions will be substantially the same.

A view which is perpendicular to both of the spanwise and chordwise directions is known as a planform view. This view looks along the thickness dimension of the blade.

30

- 35 The term “spar cap” is used to refer to a longitudinal, generally spanwise extending, reinforcing member of the blade. The spar cap may be embedded in the blade shell, or may be attached to the blade shell. The spar caps of the windward and leeward sides of the blade may be joined by one or more shear webs extending through the interior hollow space of the blade. The blade may have more than one spar cap on

each of the windward and leeward sides of the blade. The spar cap may form part of a longitudinal reinforcing spar or support member of the blade. In particular, the first and second spar caps may form part of the load bearing structure extending in the longitudinal direction that carries the flap-wise bending loads of the blade.

5

The term "shear web" is used to refer to a longitudinal, generally spanwise extending, reinforcing member of the blade that can transfer load from one of the windward and leeward sides of the blade to the other of the windward and leeward sides of the blade.

10

The term "blade portion" refers to a spanwise portion of a segmented or split blade which comprises a plurality of blade portions which are joined together to form the complete blade. For instance, the wind turbine blade may include a first wind turbine blade portion and a second wind turbine blade portion, which may be connected at a joint interface to form the blade. It will be understood that a blade may have three or more blade portions with a joint between adjacent blade portions. A blade portion may be a portion that has been cut from a one-piece wind turbine blade.

15

Figure 1 shows a wind turbine 1 including a tower 10 mounted on a foundation and a nacelle disposed at the apex of the tower 10. The wind turbine 1 depicted here is an onshore wind turbine such that the foundation is embedded in the ground, but the wind turbine 1 could be an offshore installation in which case the foundation would be provided by a suitable marine platform.

20

Blades 30, 40, 50 project outwardly from a central hub 20 and together form a rotor. It will be noted that the wind turbine 1 is the common type of horizontal axis wind turbine (HAWT) such that the rotor is mounted at the nacelle to rotate about a substantially horizontal axis 2 defined at the centre at the hub 20. While the example shown in figure 1 has three blades, it will be realised by the skilled person that other numbers of blades are possible. The rotor is operatively coupled via a gearbox to a generator (not shown) housed inside the nacelle.

25

30

When wind blows against the wind turbine 1, the blades 30, 40, 50 generate a lift force which causes the rotor to rotate, which in turn causes the generator within the nacelle to generate electrical energy.

35

Figure 2 illustrates one of the wind turbine blades 30 for use in such a wind turbine 1. The wind turbine blade 30 shown in figure 2 may be implemented for any or all blades 30, 40, 50 shown in the wind turbine 1 of figure 1. The blade 30 has a root end 33 proximal to the hub 20 and a tip end distal from the hub. A leading edge and a trailing edge extend between the root end and tip end, and the blade 30 has a respective aerodynamic high pressure surface (i.e. the pressure surface) and an aerodynamic low pressure surface (i.e. the suction surface) surface extending between the leading and trailing edges of the blade 30. As shown in figure 2, the blade 30 is a segmented or split blade and in the illustrated example comprises two blade portions, a root blade portion 31 and a tip blade portion 32. It will be appreciated that the blade may comprise more than two segmented portions.

In the field of wind turbine manufacture, there is a need to understand the mechanical properties of a wind turbine blade, to understand how the blade will perform when installed as part of a wind turbine 1. In a known method of testing a complete wind turbine blade, the complete blade is tested by attaching a root end of the blade to a “dummy hub”, and subjecting the blade to forces and torques equal to or similar to those that the blade may be exposed in use, when installed as part of a wind turbine. The dummy hub is a component which can simulate a hub to which the blade is attached during installation, but differs in that it is adapted for use in a testing environment. In this known method, a whole blade 30, 40, 50 is tested, using the dummy hub.

The inventor of the present invention has identified that improvements can be made to known testing methods, in particular to those used to test the mechanical properties of blades having multiple portions, such as the segmented blade 30 having root and tip portions 31, 32 shown in figure 2. The inventor of the present application has found that testing blade portions separately from one another can be advantageous. For example, it is not necessary for all of the blade portions to be manufactured before they can be tested. The blade portions may be manufactured and/or tested in different locations. All of the blade portions do not need to be joined together in order to be tested. Whilst the root end of any blade is adapted to be mounted to a hub in use, which presents a suitable mounting to a dummy hub in a test environment, the root end of an outboard portion of a segmented blade does not have a suitable structure for easily mounting to a dummy hub. The inventor has therefore devised the component referred

to herein as a mounting structure 3. An example of a mounting structure 3 can be seen in figure 3.

The mounting structure 3 is suitable for securing the tip blade portion 32 (or any
5 outboard blade portion or portions for a blade comprising more than two segmented portions) to a testing apparatus for mechanical testing, and comprises a base component 100, at least one cantilever arm 200, and at least one tie rod 300. The mounting structure 3 is configured such that a root end 34 of the tip blade portion 32 can be secured in place to or by the cantilever arm 200 by a clamping force exerted by
10 the at least one tie rod 300.

Where at least two cantilever arms are provided, the base component 100 may be configured to act as a bridge between the cantilever arms 200 and attach the cantilever arms 200 to each other. The base component 100 may be configured for direct or
15 indirect attachment to a testing apparatus, which may include a ring bearing and a dummy hub. Alternatively or in addition, the testing apparatus may comprise a production hub, which may be mounted on a rig. The rig may comprise at least one, preferably two, dummy blade portions, attached to the hub. Where the hub comprises three faces, and dummy blade portions occupy two of the faces, the remaining face
20 may be used for blade portion testing.

The base component 100 may be any suitable shape, preferably a shape which is mass-balanced about a central point or axis. The base component 100 may have a substantially square outer shape, although other suitably-shaped base components
25 100 may be used. The base component 100 may be substantially planar, and may be a base plate having a plate-shape. Figure 5 shows a base plate 100.

The base component 100 may define a central aperture 150. The aperture 150 may provide access from a rear side of the mounting structure 3 to the blade portion 32,
30 through the aperture 150. The aperture 150 may be circular, and/or may be arranged in the centre of the base component 100 such that the base component 100 is substantially mass-balanced and/or symmetrical, preferably substantially rotationally symmetrical about a central point or axis 101.

The base component 100 may comprise a stem 120 and a body portion 130. The body portion 130 may be substantially planar and at least partly define the aperture 150. The stem 120 may extend from the body portion 130 in a substantially perpendicular direction to a plane defined by the body portion 130, which may be in a direction parallel to the central axis 101. The stem 120 may at least partly define the aperture 150. A ridge or plurality of ridges 110 may be provided on the base component 100, which may extend between the stem 120 and the body portion 130, so as to strengthen the base component 100.

10 The base component 100 may comprise a metal and/or alloy, and preferably may comprise or be composed of structural steel.

The or each cantilever arm 200 is configured to function as structural supporting components, which can support other components of the mounting structure 3 to which the tip blade portion 32 is attached, such as cross-beams 500 and/or tie rod or rods 300.

The or each cantilever arm 200 is attached or attachable to the base component 100. When attached to the base component 100 they extend therefrom, and may be arranged so as to be substantially equidistant to each other from a central point or axis 101 of the base component 100.

Any suitable number of cantilever arms 200 may be used. There may be at least two, preferably at least three, further preferably at least four cantilever arms 200, for example as shown in figure 3. The or each cantilever arm 200 may be arranged or configured so that the mounting structure 3 is mass-balanced about a central point or axis 101. Where the base component 100 is substantially square-shaped, there may be a cantilever arm 200 provided at or towards each corner of the base component 100.

30

Each cantilever arm 200 may have a root end 201 and a tip end 202, the root end 201 being disposed at and/or attached to the base component 100 when the mounting structure 3 is in an assembled state. The root end 201 may be wider than the tip end 202. Each cantilever arm 200 may be substantially hollow, and/or may comprise or be

composed of structural steel. Each cantilever 200 may have a length from its root end 201 to its tip 202 of at least 1 metre, preferably at least 3 metres.

5 The root end 201 of at least one of the cantilever arms 200 may be fixed in position relative to other components of the mounting structure 3, such as the base component 100. At least one or all of the cantilever arms 200 may be fixed directly to the base component 100. The fixed connection may comprise one or more of: a pin and bolt connection, threaded connection, adhesive, or any other suitable fixed attachment component. Alternatively, or in addition, at least one of the cantilever arms 200 may be
10 formed integrally with the base component 100.

A root end 201 of at least one of the cantilever arms 200 may be adjustably connected to the base component 100. The adjustable connection may comprise an elongate aperture, and may comprise a pin (not shown). The pin may be translatable along the
15 elongate aperture when in an installed state. The elongate aperture may extend in the base component 100 or in the cantilever arm 200 in a radial direction of a blade portion cross-section when the blade portion 32 is installed in the mounting structure 3. This radial direction may extend radially away from a central axis 101 of the base component 100 when the cantilever arms 200 and base component 100 are attached to each other.
20 Alternatively or in addition, the elongate aperture may extend in a transverse direction of the blade portion cross-section when the blade portion 32 is installed in the mounting structure 3.

At least one of the cantilever arms 200 may be fixedly attached to the base component
25 100, and another of the cantilever arms 200 may be adjustably attached to the base component 100. This has the advantage of providing an adjustable arrangement in which the distance between the cantilever arms 200 can be adapted to the shape and size of the blade portion 32 to be tested. Use of at least one fixed attachment on at least one cantilever arm 200 in combination with an adjustable attachment on another
30 cantilever arm 200 provides a reduced manual effort for the user of the mounting structure 3, while still providing the option of adjusting the mounting structure 3.

The at least one tie rod 300 is configured to extend through the blade portion 32, and may extend through the profile insert 400 and inner profile 600.

There may be provided at least two tie rods 300, at least four tie rods 300, or any suitable number of tie rods 300. The tie rods 300 may be configured to exert a clamping force on the blade portion 32.

5 The or each tie rod 300 may comprise a securing component, configured to restrict movement of the tie rod 300 relative to a cross beam 500 and/or cantilever arm 200. The tie rod 300 may comprise a tie rod body 303 and the securing component may comprise a first radially enlarged end 301, preferably first and second radially enlarged ends 301, 302. The radially enlarged end(s) 301, 302 are configured to secure the tie
10 rod 300 relative to the other components of the mounting structure 3, in particular the cross-beams 500. The or each radially enlarged end(s) 301, 302 may prevent the end of the tie rod 300 from passing through an aperture 558 provided in the cross-beam 500, allowing the mounting structure 3 and/or blade portion 32 to exert a tensile stress on the tie rod 300. The or each radially enlarged end(s) 301, 302 may comprise a bolt,
15 which may be attached to the tie rod body 303 through use of a threaded connection. The or each radially enlarged end(s) 301, 302 may comprise a washer, as shown in figure 4. Provision of a separate, attachable component, and a threaded connection, has the advantage of providing an adjustable tie rod 300 which is easy to assemble and adjust.

20

The at least one tie rod 300 may comprise or be composed of a metal or alloy, preferably high tensile strength steel.

The mounting structure 3 may comprise a profile insert 400. The profile insert 400 may
25 have at least one contacting wall 401, 402, and the contacting wall 401, 402 may define an opening 450. As a mere schematic illustration of the mounting structure 3, a rectangular block is shown as received in the opening 450 of figure 3, in place of a blade portion 32. The opening 450 may be configured to receive at least part of a blade portion 32, as shown in figure 4. The contacting wall 401, 402 may be shaped so as to
30 align with and contact the blade portion 32, in particular an outer surface of a blade portion 32, such as a metal outer foil of a blade portion 32. The profile insert 400 may comprise at least two separable parts 410, 420. Each part 410, 420 may have a contacting wall 401, 402. The contacting walls 401, 402 may each contact opposing sides of a blade portion 32 when a blade portion 32 is installed in the mounting structure
35 3.

When installed into the profile insert 400, the blade portion 32 may not be fully encapsulated within the insert 400, and instead may extend transversely from the insert 400, for example as shown in figure 4.

5

The profile insert 400 may comprise or be composed of wood, plastic, or any other suitable material. In an advantageous embodiment, the profile insert 400 may comprise or be composed of plywood.

10 The mounting structure 3 may further comprise at least one inner profile 600. The inner profile 600 is configured to be received in the wind turbine blade portion 32. The inner profile is configured to align with an inner surface of the blade portion 32. The inner profile 600 may be provided as multiple separate pieces, so as to fit around one or more shear webs of the blade portion 32. The inner profile may be configured or
15 adapted to receive one or more of the tie rods 300.

The inner profile 600 may comprise or be composed of wood, plastic, or any other suitable material. In an advantageous embodiment, the inner profile 600 may comprise or be composed of plywood.

20

The mounting structure 3 may comprise a pair of cross-beams 500. A cross-beam 500 can be seen in figure 6.

When installed, the cross-beams 500 may extend in a transverse direction between
25 the cantilever arms 200, such as in a direction perpendicular to an extension direction of the cantilever arms 200. One or more of the cross-beams 500 may be elongate, so as to extend between the cantilever arms 200.

The mounting structure 3 may comprise at least two pairs of cross-beams 510, 520,
30 530, 540. One pair of the cross-beams 510, 520 may be spaced apart from another pair 530, 540 along the cantilever arms 200 in the direction of extension of the cantilever arms 200, for example as shown in figure 3. One or more of the cross-beams 510, 520, 530, 540 may be adjustable within the mounting structure 3 relative to another of the cross-beams 510, 520, 530, 540.

35

One of the cross-beams 500, more preferably each cross-beam 510, 520, 530, 540, may comprise at least one aperture 558, which may be configured to receive at least part of the at least one tie rod 300. The at least one aperture 558 may be larger than a cross-section of the tie rod body 303, and/or smaller than a radially enlarged end 301, 302 of the tie rod 300.

At least one of the cross-beams 500 may form a recess 550. The recess 550 may be configured to receive at least part of the profile insert 400. The cross-beams 510, 520, 530, 540 may be configured to hold each part 410, 420 of a profile insert 400 in place relative to the cantilever arms 200.

The recess 550 may be at least partly bounded by one or more walls 551, 552, which extend from a body 553 of the cross-beam 500. The body 553 of the cross-beam 500 may define a plane, and the walls 551, 552 may extend in a perpendicular direction from the plane defined by the body 553. The walls 551, 552 may be substantially elongate, and extend parallel to each other. The walls 551 552 may be configured to align with outer sides of the profile insert 400 when a profile insert 400 is received in the recess 550, so as to provide an easily assembled and robust arrangement.

One or more of the cross-beams 500 may comprise at least one recess, 554, 555, configured to receive at least part of a cantilever arm 200. Where four cantilever arms 200 are provided, each cross-beam 500 may comprise two recesses 554, 555. This has the advantage of providing an easily assembled arrangement.

The or each cross-beam 500 may comprise or be composed of structural steel.

All of the components described herein are advantageous in that they provide a mounting structure 3 suitable for testing a blade portion 32. The mounting structure 3 is advantageous in that an outer surface of the blade portion 32, (for example a blade skin with a foam core) only experiences moderate clamping loads when installed in the mounting structure 3.

The mounting structure 3 as described with any of the features outlined above may be provided as part of a wind turbine blade portion test assembly 4, such as the

assemblies shown in figures 4 and 7. The wind turbine blade portion test assembly 4 may comprise a wind turbine blade portion 32.

5 The or each tie rod 300 may extend through the outer shell of the blade portion 32 away from the spar caps or stringers which may be attached to the inner surface of, or may be embedded within, the blade shell, for example as shown in figure 4. The or each tie rod 300 may extend to one side of the spar cap, which may comprise carbon fibre pultrusions, of the wind turbine blade portion 32. Preferably, the tie rod or rods 300 are arranged so as to not extend through any pultrusions within the blade portion 10 32. The tie rod or rods 300 may be arranged so as to extend alongside any pultrusion within the blade portion 32.

A root end face of the wind turbine blade portion 32 may project from the one or more tie rods 300 towards the base component 100. In the assembly 4, the root end face of 15 the wind turbine blade portion 32 may not be directly attached to the mounting structure 3. A tip end of the wind turbine blade portion 32 may project from the one or more tie rods 300 away from the mounting structure 3.

The wind turbine blade portion test assembly 4 may further comprise a ring bearing 20 701. The ring bearing 701 may be configured to allow rotation of the blade portion 32, relative to a fixed component such as a dummy hub 700. The ring bearing 701 may be fastened to the base component 100. The ring bearing 701 may be attached to a dummy hub 700, which may be secured to the ground 703. The wind turbine blade portion test assembly 4 may further comprise a hydraulic ram 702.

25

The mounting structure 3 and assembly 4 may be configured to test a blade portion having dimensions of approximately 20 to 60 metres in length, e.g. 46 metres in length, a chord length at its root of approximately 2 to 6 metres, e.g. 3.7 metres, and a thickness at its root of approximately 0.5 to 3 metres, e.g. 1 metre.

30

When the blade portion 32 is installed into the mounting apparatus 3, for example as shown in figure 7, mechanical tests can be performed on the blade portion 32. Possible mechanical tests include but are not limited to strength analysis, vibrational analysis, torsion testing, and fatigue testing.

35

In terms of the steps of installing a blade portion 32 into a testing apparatus, installation may comprise:

- providing a blade portion 32,
- providing the mounting structure 3 of any of the examples described above,
- 5 locating a root end of the blade portion 32 at the at least one cantilever arm 200, and
- securing the cantilever arm 200 so as to exert a clamping force from the cantilever arm 200 on the blade portion 32.

- 10 The blade portion in the support structure for testing may be a tip blade portion 32 and/or an intermediate portion(s) of a multiple-portion blade. Where the blade portion to be tested is an intermediate blade portion of a multiple portion blade, the intermediate portion being disposed between tip and root blade portions when installed on a wind turbine 1, weights can be used at a tip end of the intermediate blade portion
- 15 during testing using the mounting structure 3, so as to simulate forces on the intermediate blade portion from a tip portion 32 or other intermediate blade portion in use.

- 20 Although the invention has been described above with reference to one or more preferred embodiments, it will be appreciated that various changes or modifications may be made without departing from the scope of the invention as defined in the appended claims.

CLAIMS

1. A mounting structure for securing a wind turbine blade portion to a testing apparatus for mechanical testing, the mounting structure comprising:
- 5 a base component;
- at least one cantilever arm attached to, and extending from, the base component; and
- at least one tie rod configured to extend through the blade portion;
- wherein the mounting structure is configured such that a root end of the blade portion
- 10 can be secured in place by the at least one cantilever arm by a clamping force exerted by the at least one tie rod.
2. The mounting structure of claim 1, wherein the cantilever arm is at least two cantilever arms, preferably four cantilever arms.
- 15
3. The mounting structure of claim 1 or claim 2, comprising a profile insert having at least one contacting wall defining an opening in which at least part of the blade portion can be received, the contacting wall being shaped so as to align with and contact a blade portion.
- 20
4. The mounting structure of claim 3, wherein the profile insert comprises at least two separable parts, each part having a contacting wall, the contacting walls each contacting opposing sides of a blade portion when a blade portion is installed in the mounting structure.
- 25
5. The mounting structure of any of the preceding claims, further comprising at least one inner profile, configured to be received in the wind turbine blade portion.
6. The mounting structure of any of claims 2 to 5, comprising a pair of cross-beams
- 30 extending in a transverse direction between the cantilever arms.
7. The mounting structure of claim 6, comprising at least two pairs of cross-beams, one pair spaced apart from another pair along the cantilever arms in the direction of extension of the cantilever arms.
- 35

8. The mounting structure of claim 6 or claim 7, wherein one or more of the cross-beams is adjustable relative to another of the cross-beams.
9. The mounting structure of any of the preceding claims, wherein a root end of at least one cantilever arm is fixed in position to the base component.
10. The mounting structure of any of the preceding claims, wherein a root end of at least one cantilever arm is adjustably connected to the base component.
11. The mounting structure of claim 10, wherein the adjustable connection comprises an elongate aperture and a pin, the pin being translatable along the elongate aperture when in an installed state.
12. The mounting structure of claim 11, wherein the elongate aperture extends in the base component in a radial direction, and/or a transverse direction defined by the blade portion cross-section when the blade portion is fully installed into the mounting structure.
13. The mounting structure of any of the preceding claims, wherein the base component is a base plate, the base plate defining a central aperture to provide access from a rear side of the mounting structure to the blade portion.
14. A wind turbine blade portion test assembly, comprising:
the mounting structure of any of the preceding claims, and
a wind turbine blade portion.
15. The wind turbine blade portion test assembly of claim 14, wherein the or each tie rod extends to one side of at least one spar cap of the wind turbine blade portion and/or the or each tie rod extends along a side of a shear web of the wind turbine blade portion.
16. The wind turbine blade portion test assembly of claim 14 or 15, wherein a root end face of the wind turbine blade portion projects from the one or more tie rods towards the base component and/or wherein a tip end of the wind turbine blade portion projects from the one or more tie rods away from the mounting structure.

17. The wind turbine blade portion test assembly of any of claims 14 to 16, wherein the root end face of the wind turbine blade portion is not directly attached to the mounting structure.
- 5
18. The wind turbine blade portion test assembly of any of claims 14 to 17, further comprising a ring bearing configured to allow rotation of the blade portion, the ring bearing being fastened to the base component.
- 10
19. A method of installing a blade portion into a testing apparatus, comprising:
providing a blade portion,
providing the mounting structure of any of claims 1 to 13,
locating a root end of the blade portion at the at least one cantilever arm, and
securing the cantilever arm so as to exert a clamping force from the cantilever
- 15
- arm on the blade portion.
20. The method of claim 19, wherein the blade portion is a tip portion or an intermediate portion of a multiple-portion blade.

1/7

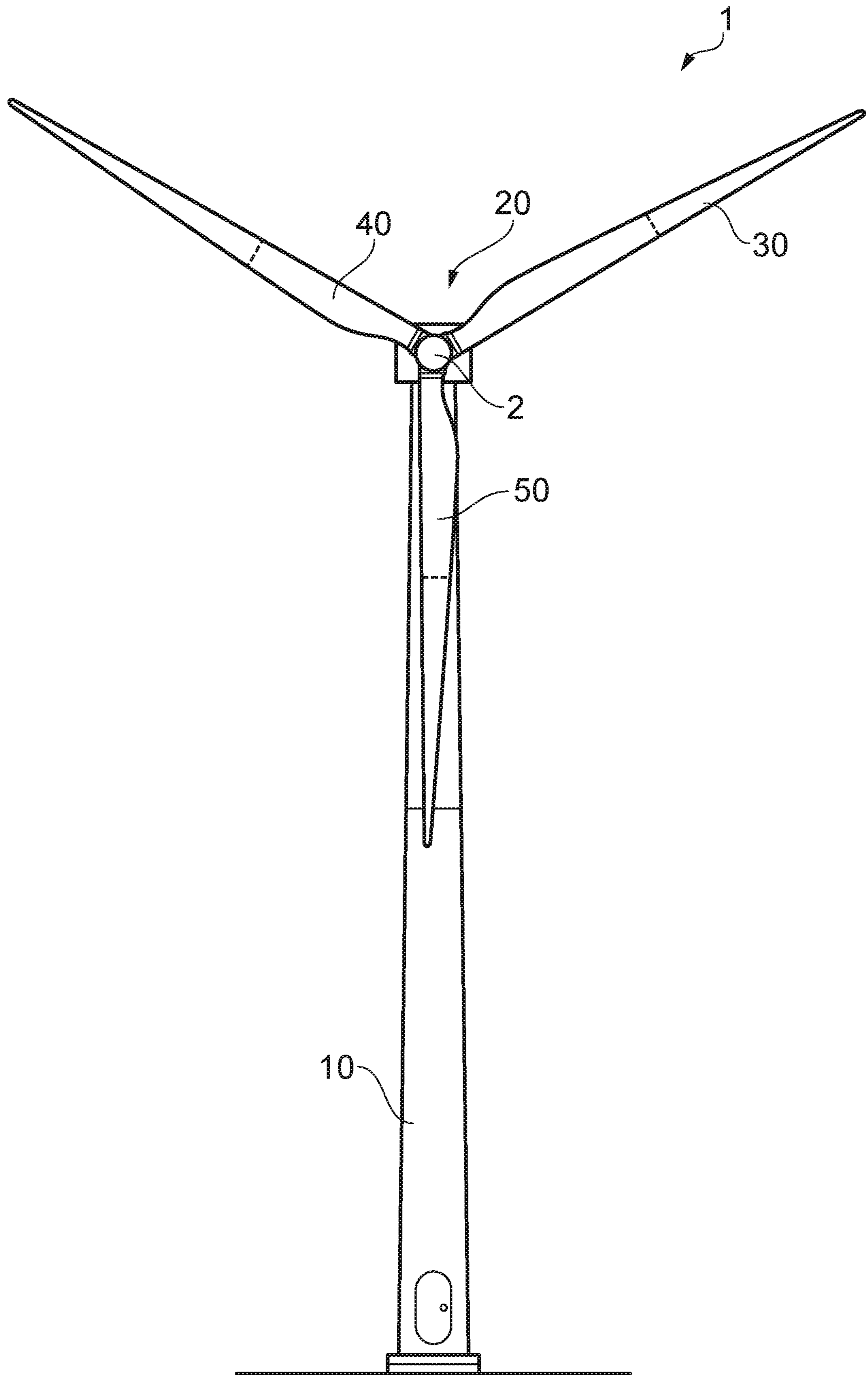

FIG. 1

2/7

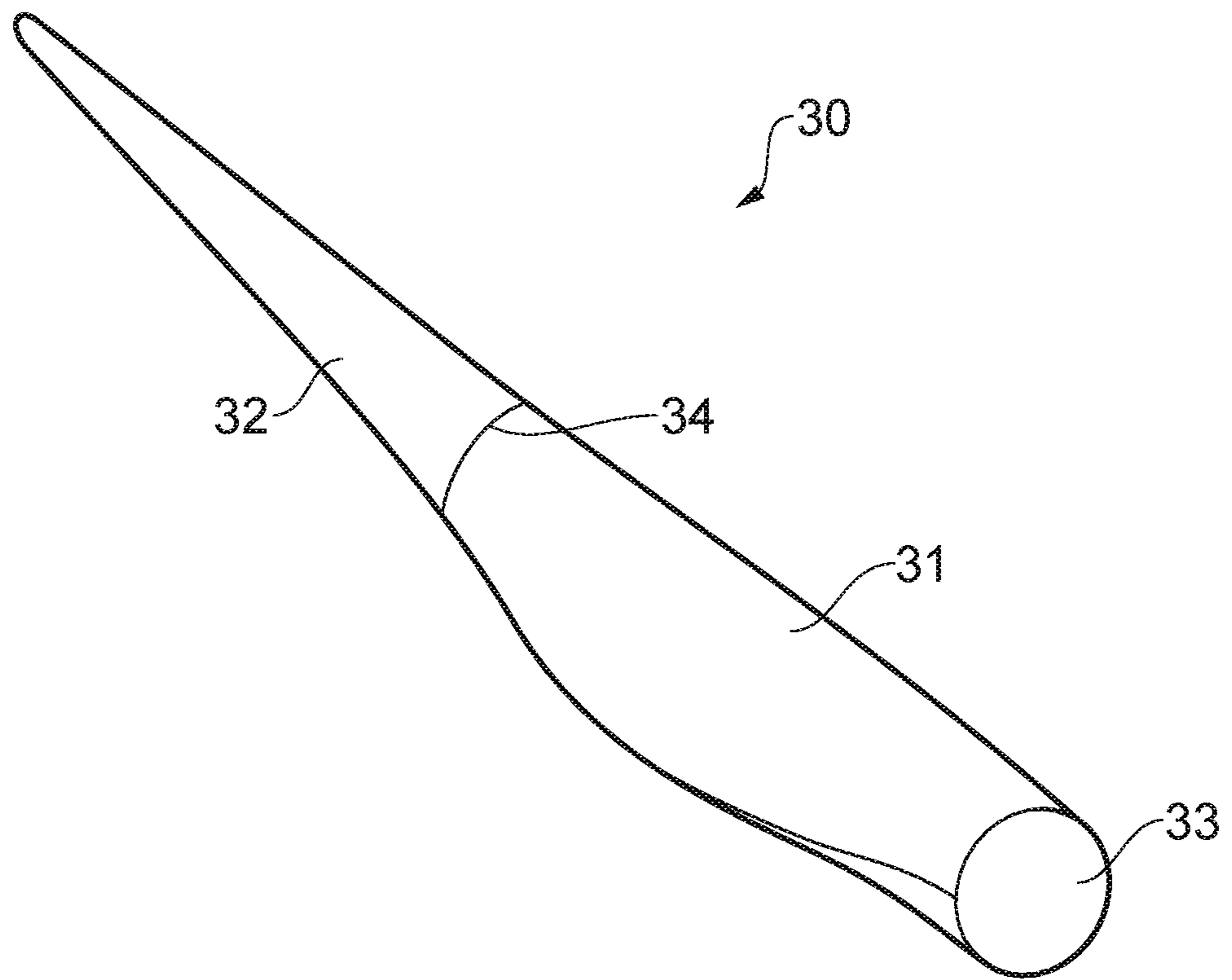

FIG. 2

3/7

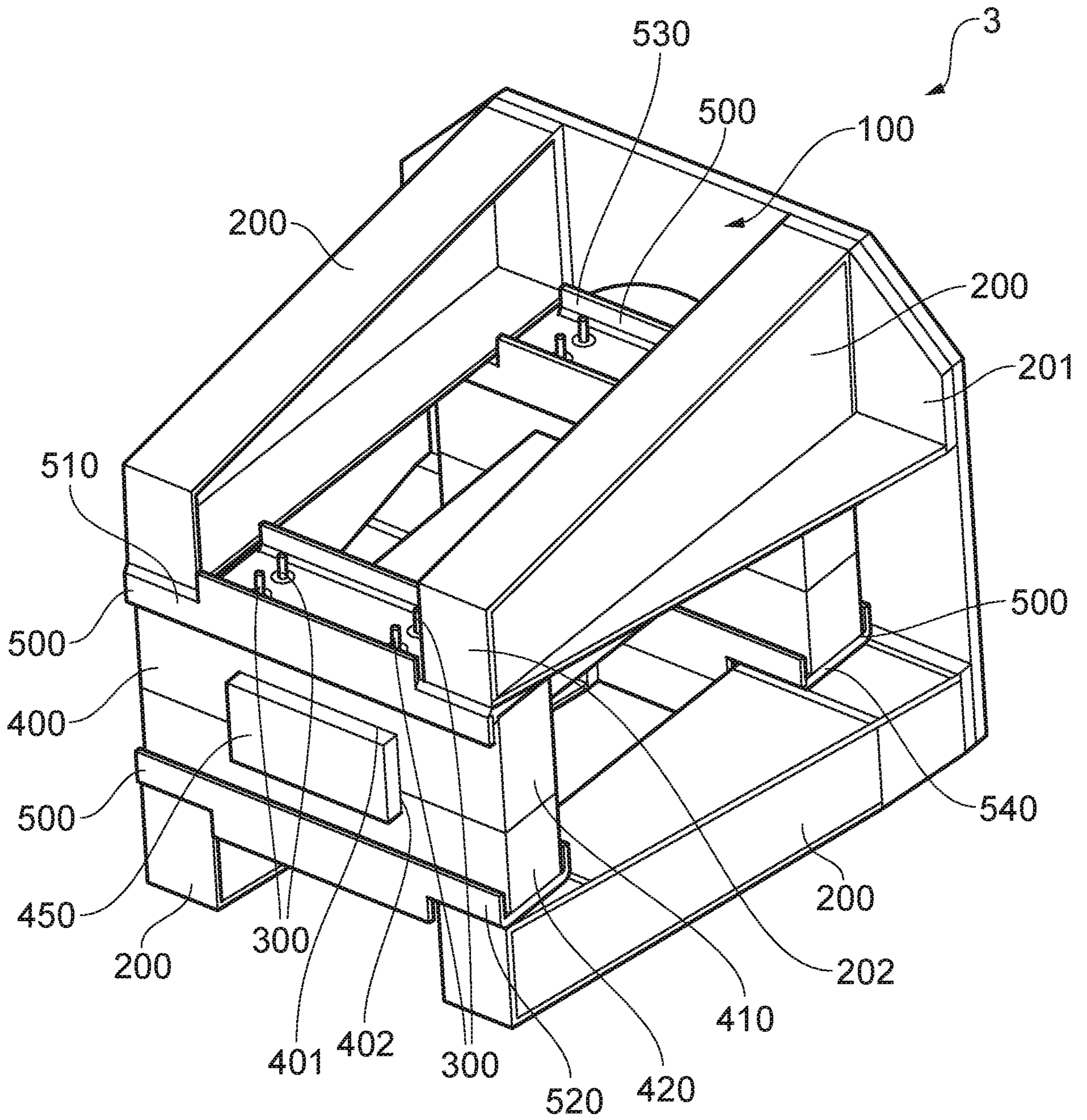

FIG. 3

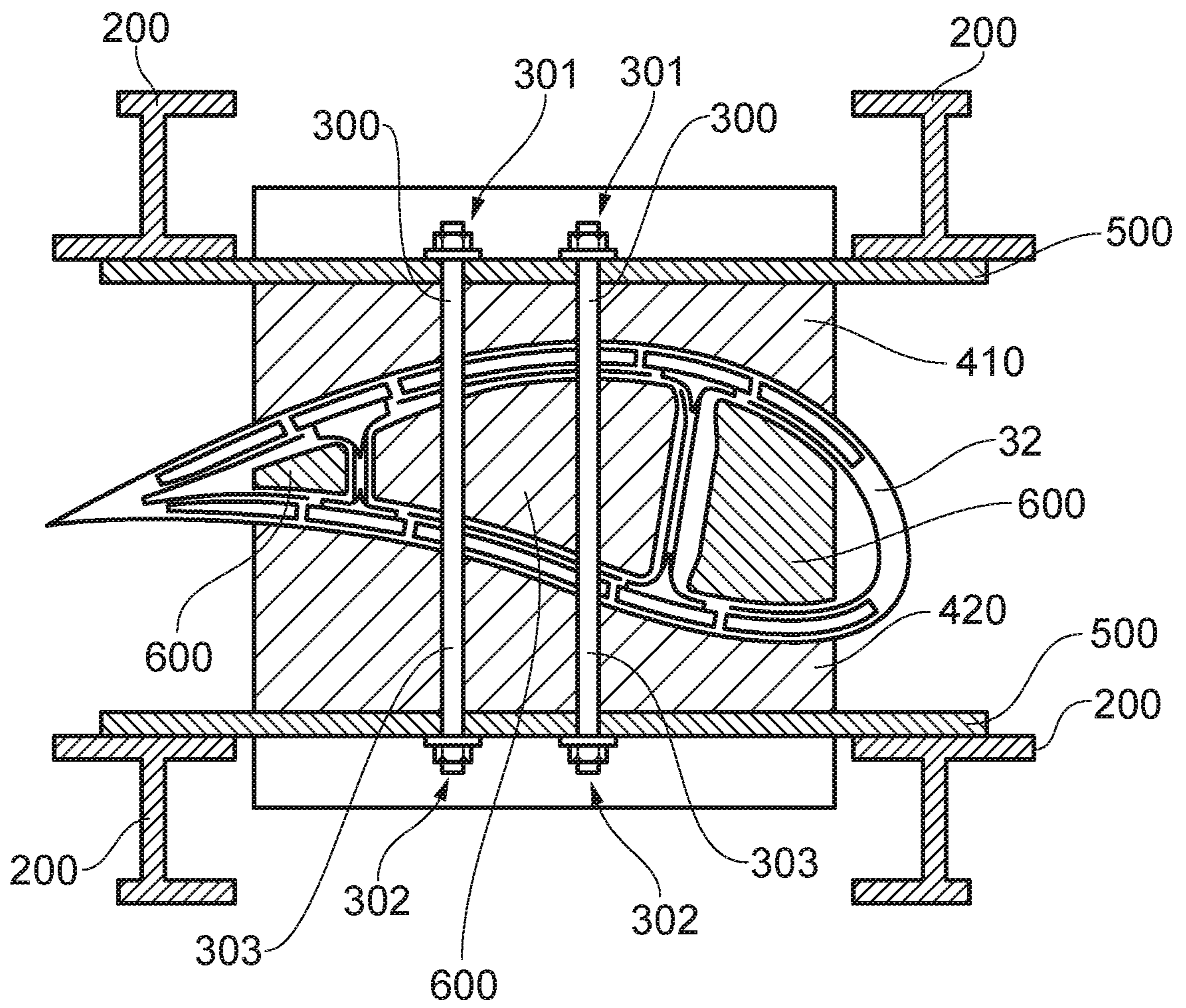

FIG. 4

5/7

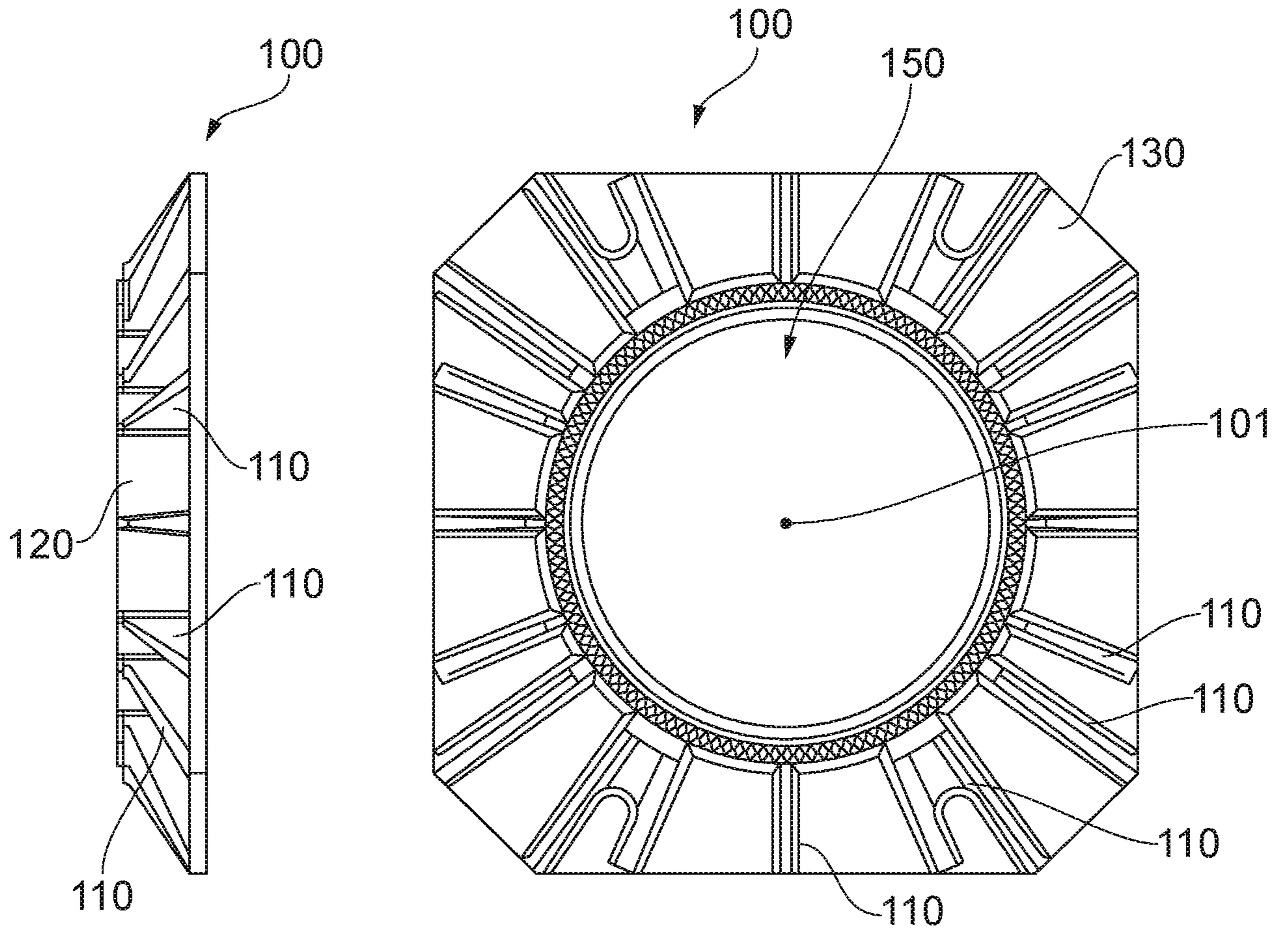

FIG. 5

6/7

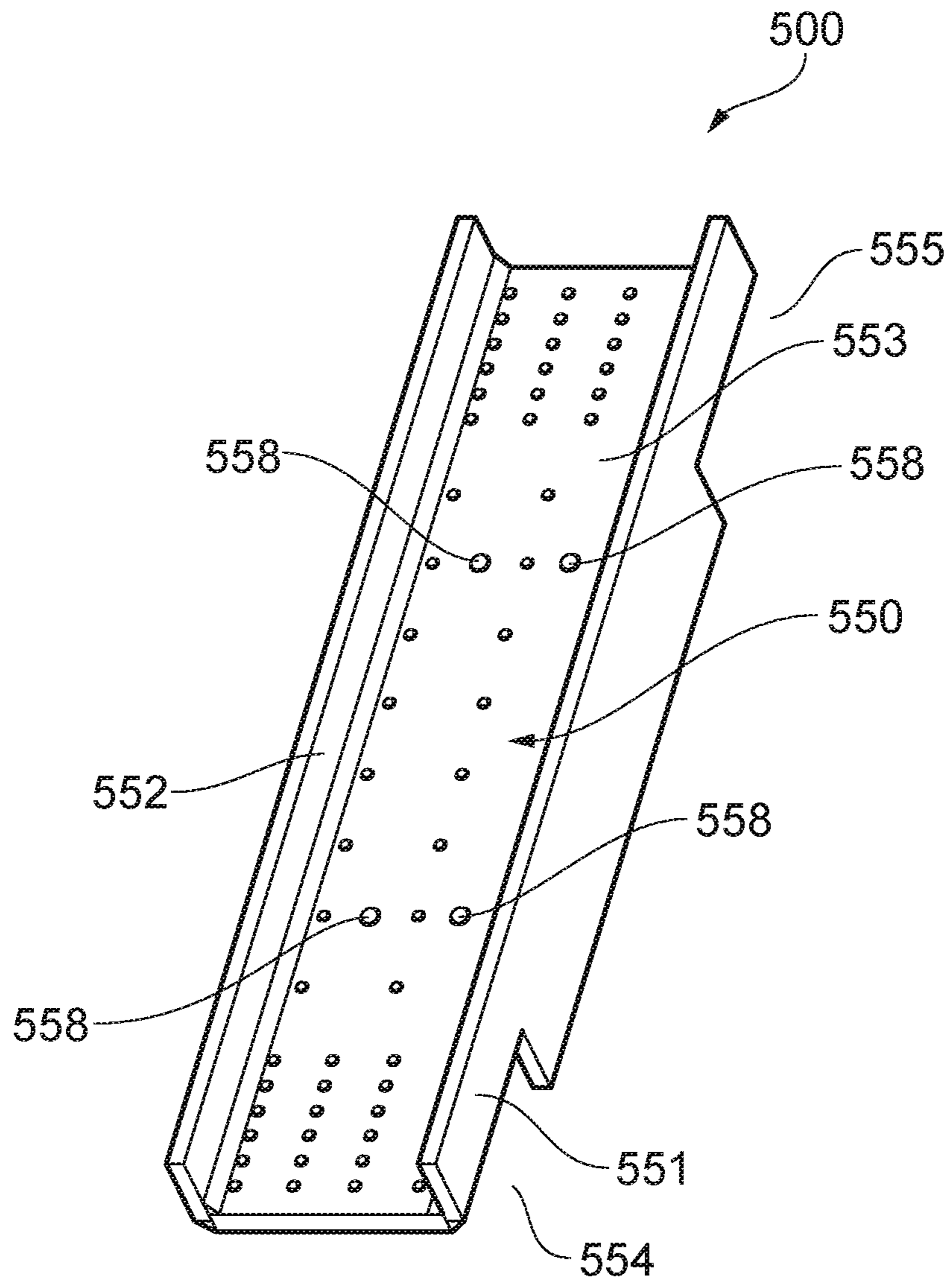

FIG. 6

7/7

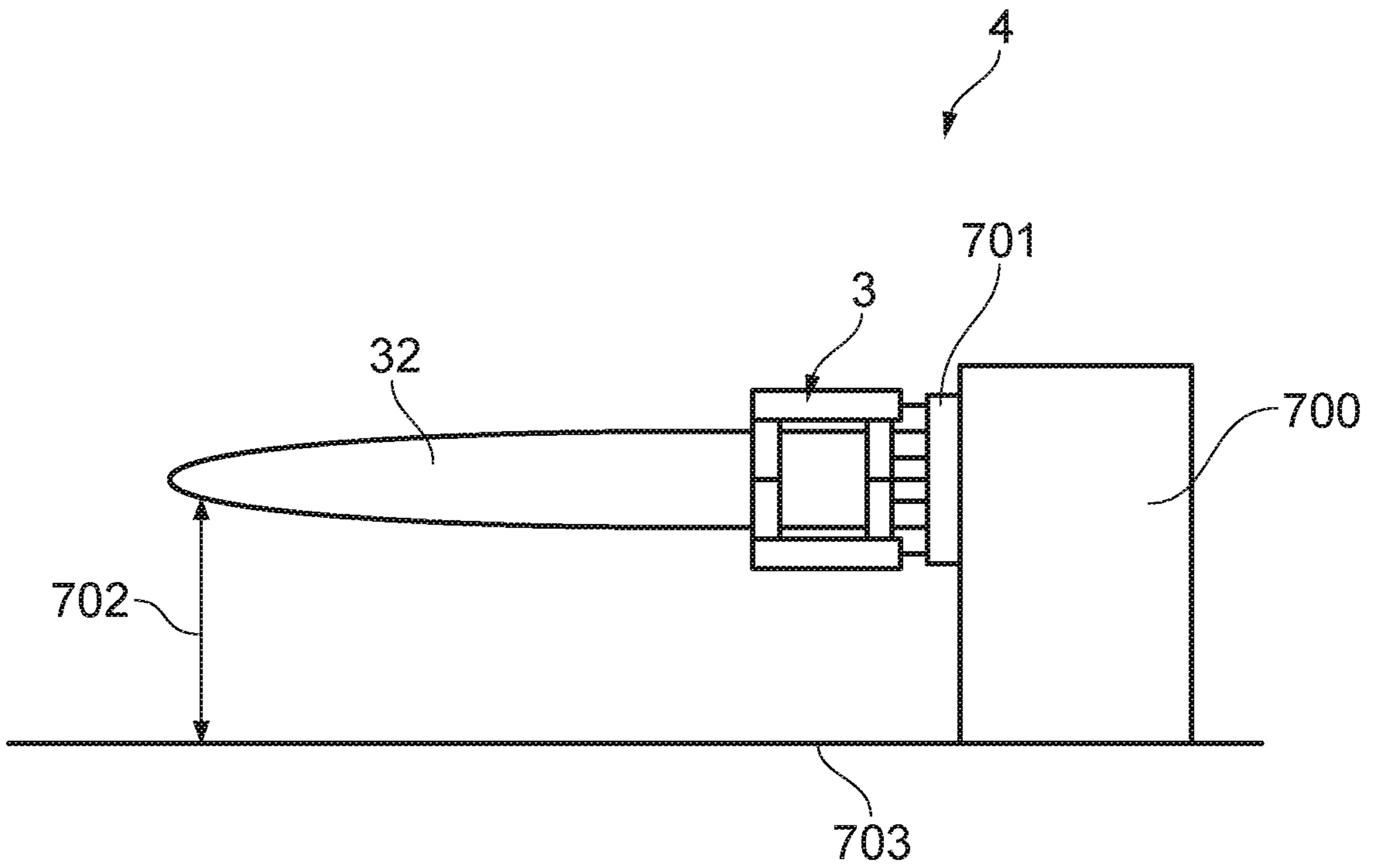

FIG. 7

INTERNATIONAL SEARCH REPORT

International application No
PCT/DK2020/050356

A. CLASSIFICATION OF SUBJECT MATTER
 INV. G01M5/00 G01M7/02
 ADD.
 According to International Patent Classification (IPC) or to both national classification and IPC

B. FIELDS SEARCHED
 Minimum documentation searched (classification system followed by classification symbols)
 G01M
 Documentation searched other than minimum documentation to the extent that such documents are included in the fields searched

Electronic data base consulted during the international search (name of data base and, where practicable, search terms used)
 EPO-Internal, WPI Data

C. DOCUMENTS CONSIDERED TO BE RELEVANT

Category*	Citation of document, with indication, where appropriate, of the relevant passages	Relevant to claim No.
X	US 2017/241860 A1 (RICHARDS WILLIAM DAVID [GB] ET AL) 24 August 2017 (2017-08-24) paragraph [0058] - paragraph [0063] figures 4-6	1-20
A	----- EP 2 336 744 A1 (SIKORSKY AIRCRAFT CORP [US]) 22 June 2011 (2011-06-22) paragraph [0020] figure 1	5
A	----- CN 103 512 732 B (SHANGHAI TONGYUN GREEN ENERGY TECHNOLOGY CO LTD) 18 November 2015 (2015-11-18) the whole document	1-20

Further documents are listed in the continuation of Box C.

See patent family annex.

* Special categories of cited documents :

- "A" document defining the general state of the art which is not considered to be of particular relevance
- "E" earlier application or patent but published on or after the international filing date
- "L" document which may throw doubts on priority claim(s) or which is cited to establish the publication date of another citation or other special reason (as specified)
- "O" document referring to an oral disclosure, use, exhibition or other means
- "P" document published prior to the international filing date but later than the priority date claimed

- "T" later document published after the international filing date or priority date and not in conflict with the application but cited to understand the principle or theory underlying the invention
- "X" document of particular relevance; the claimed invention cannot be considered novel or cannot be considered to involve an inventive step when the document is taken alone
- "Y" document of particular relevance; the claimed invention cannot be considered to involve an inventive step when the document is combined with one or more other such documents, such combination being obvious to a person skilled in the art
- "&" document member of the same patent family

Date of the actual completion of the international search

Date of mailing of the international search report

19 February 2021

03/03/2021

Name and mailing address of the ISA/
 European Patent Office, P.B. 5818 Patentlaan 2
 NL - 2280 HV Rijswijk
 Tel. (+31-70) 340-2040,
 Fax: (+31-70) 340-3016

Authorized officer

Reto, Davide

INTERNATIONAL SEARCH REPORT

Information on patent family members

International application No

PCT/DK2020/050356

Patent document cited in search report	Publication date	Patent family member(s)	Publication date	
US 2017241860	A1	24-08-2017	CN 107110736 A	29-08-2017
			DK 3198255 T3	11-03-2019
			EP 3198255 A1	02-08-2017
			US 2017241860 A1	24-08-2017
			WO 2016045684 A1	31-03-2016

EP 2336744	A1	22-06-2011	EP 2336744 A1	22-06-2011
			US 2011146375 A1	23-06-2011

CN 103512732	B	18-11-2015	NONE	
