

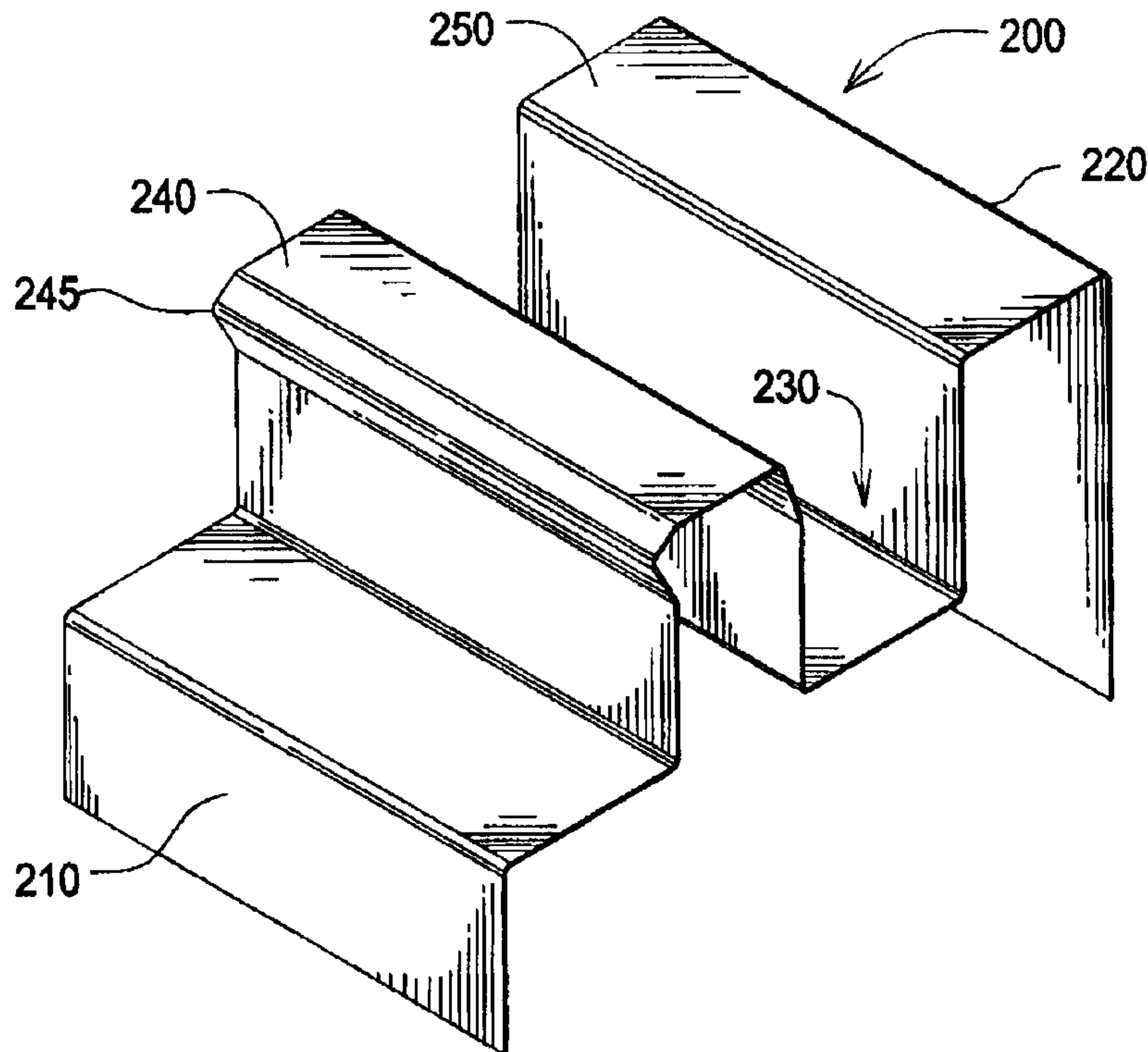

(22) Date de dépôt/Filing Date: 2009/02/24
(41) Mise à la disp. pub./Open to Public Insp.: 2009/09/04
(30) Priorité/Priority: 2008/03/04 (US12/042,043)

(51) Cl.Int./Int.Cl. *E04F 13/21* (2006.01),
E04F 13/12 (2006.01), *E04F 13/24* (2006.01)
(71) Demandeur/Applicant:
CARSON, CRAIG D., US
(72) Inventeur/Inventor:
CARSON, CRAIG D., US
(74) Agent: BORDEN LADNER GERVAIS LLP

(54) Titre : METHODE ET ELEMENTS D'INSTALLATION D'UN SYSTEME MURAL
(54) Title: METHOD AND APPARATUS FOR MOUNTING A WALL SYSTEM



(57) Abrégé/Abstract:

Disclosed is a wall system employing one or more stackable connectors that are capable of engaging one with another independent of fasteners and being mountable to a respective wall panel.

ABSTRACT

Disclosed is a wall system employing one or more stackable connectors that are capable of engaging one with another independent of fasteners and being mountable to a respective wall panel.

TITLE

Method and Apparatus for Mounting a Wall System

FIELD OF ART

5 The disclosed device relates generally to a panelized metal wall system for exterior wall cladding in the building industry, and more specifically to a metal stud wall system employing one or more stackable connectors that are capable of engaging one with another independent of fasteners and being mountable to a respective wall panel.

BACKGROUND

10 It is well known in the building industry that the term “cladding” is used to refer to a wide variety of natural, synthetic, or man-made building envelope materials and components. Panelized metal wall systems are but one form of cladding suitable for installation as an exterior side of a building enclosure. Other types of cladding can
15 include cast in place concrete, pre-cast concrete, masonry, etc. In selecting the types of metal panels that meet design criteria for a particular building envelope, a designer will typically establish panel performance criteria related (but not limited) to wind loading, seismic considerations, deflection, thermal movement, air infiltration, moisture management, panel flatness, panel tolerance, performance testing, fire resistance, sound
20 transmission, insulation, and/or maintainability.

 Each wall system is typically adapted to its intended building use. Thus, a metal wall building envelope can comprise flat plate metal panels, lap seam metal panels, composite metal panels, and/or metal-faced composite panels. In addition, the type of metal typically can include aluminum, steel, stainless steel, or copper. Steel panel
25 systems, however, may necessitate a protective coating for corrosion resistance. Metal panels are typically screwed or bolted directly on a structural frame often consisting of metal studs. Ideally, the design of the metal stud framing should be integrated with the panel design and the relevant fastening system.

Often a metal panel will be selected almost solely for the overall look it provides with little consideration for the method of panel engagement. Decisions based on aesthetics alone can often overlook issues related to one or more of the above-mentioned design criteria, and vice versa. For example, systems that employ a tongue and groove method of engagement can result in a seam vulnerable to water infiltration. Lap seam metal panels, on the other hand, can remedy the water infiltration problem but the use of these panels can result in exposed fasteners, which then require maintenance to prevent leaks at the fastener locations. Since lap seam metal panels do not readily accommodate the issue of thermal movement, panel lengths may become limited. Recent developments in the industry have resulted in metal wall panels that can offer the appearance of a lap seam panel but use interlocking cleats to secure the panel to the structure without the use of exposed fasteners, thereby providing improved appearance, weather tightness, and management of thermal movement. In short, conventional panels can provide a system having a plurality of panels that interlock with one another in an end-to end manner. In addition, with the conventional art, metal panels appear to be erected directly on the exterior of the metal stud framing and add little or no stress benefit. Not only can the disclosed device provide for a metal wall panel system that can accommodate aesthetics, it can facilitate a secure and beneficial method of panel engagement.

The building envelope has been a target of innovation. Developments in the wall systems of the envelope are generally attributed to: 1) cost reduction for a competitive market, 2) material innovation, 3) enhanced performance, and 4) aesthetics. The Applicant has developed a device that enhances the building envelope industry and can provide a cost-effective and high-performance method of constructing a metal wall panel system. Further, the disclosed device can be instrumental in facilitating a wall system with a high aesthetic level.

If properly designed and constructed, metal panel systems can require little maintenance. It is well known in the industry, however, that the quality and integrity of metal panel systems can vary by vendor, installer, or other contractor or subcontractor. In addition, problems associated with fabrication, design, shipping and handling, or

installation can affect the appearance and/or performance of one or more panels or the wall system itself. The disclosed device can help to alleviate such problems, thereby increasing the likelihood that a metal panel system is properly constructed and/or installed which can result in an increase in maintainability.

5 Not only does the disclosed device provide for ease and consistency of installation, but if desired, any number of exterior finish products can be pre-installed off-site (*i.e.*, unitized system) or applied in situ (*i.e.*, stick system) to optimize a building envelope project. Examples of exterior finish products can include but is not limited to metal, stucco, tile, brick, etc.

10

SUMMARY OF THE DISCLOSURE

The disclosed device provides a metal wall panel system comprising one or more metal plates bent to a desired profile and capable of forming a connection system. The connection system is capable of forming a horizontal joint that can accommodate building
15 movements by means of effective load transfer.

The connectors can mate with each other independent of fasteners wherein a leg element of a first connector interlocks a corresponding receiving member or track of a second connector. In addition, the shape of each of the connectors can be fabricated so as to be uniform one with another, which can thereby reduce the overall cost of the
20 system. In operation, the connectors mate by simply reversing or rearranging one of a pair of connectors and interlocking the pair.

These and other advantages of the disclosed device will appear from the following description and/or appended claims, reference being made to the accompanying drawings that form a part of this specification wherein like reference characters designate
25 corresponding parts in the several views.

BRIEF DESCRIPTION OF THE FIGURES

FIG. 1A (prior art) is a perspective view of a typical corrugated metal wall panel.

FIG. 1B (prior art) is a front view of the wall panel shown in **FIG. 1A**.

FIG. 2 (prior art) is an elevation view of a metal stud framing system.

FIG. 3 (prior art) is a perspective view of a typical exterior finish product mounted over a metal stud frame.

FIG. 4 is a perspective view of one embodiment of the connector disclosed herein.

5 **FIG. 5** is a side view of the connector of **FIG. 4** shown to be mateable with a second connector.

FIG. 6 is a side elevation view of a pair of mateable connectors, each mounted to a portion of a respective stud and capable of being affixed to a wall panel.

Before explaining the disclosed embodiments of the disclosed device in detail, it
 10 is to be understood that the device is not limited in its application to the details of the particular arrangements shown, since the device is capable of other embodiments. Also, the terminology used herein is for the purpose of description and not of limitation.

DESCRIPTION OF THE DISCLOSED FIGURES

15 The following description is provided to enable any person skilled in the art to make and use the disclosed apparatus. Various modifications, however, will remain readily apparent to those skilled in the art, since the generic principles of the present apparatus have been defined herein specifically to provide for either a unitized or stick system capable of connection with a metal stud framing system.

20 Metal wall panels can be flat or corrugated sheets of metal manufactured to provide wall cladding for a building exterior and may be fabricated in a variety of styles and types. Stiffeners and support structure can be welded or adhered thereto. **FIGS. 1A, 1B** depict a conventional corrugated metal wall panel **10** capable of being mounted on a metal stud frame generally used for rough-framing in commercial or residential
 25 construction and many other applications.

As shown in **FIG. 2**, a metal stud frame typically consists of two main components: 1) the track and 2) the stud. The dimension of a room is generally established with horizontal track members **100, 110** anchored respectively to the floor slab **120** and ceiling joist(s) (not shown) to outline the room. Horizontal members

transfer floor or roof loads to the structural components, *i.e.*, beams, girders, columns, etc., of a building. The vertical studs **130** are arranged in the tracks **100, 110**, usually spaced about 16" apart, and fastened at the top and bottom by means of conventional fasteners, such as wafer screws, framing screws or welding. This can create a structural framework **140** to support metal wall panels **150** or other finish materials as shown in **FIG. 3**. Stud **130** constitute structural building components that support vertical loads and can transfer lateral loads.

The device disclosed herein may be fabricated in a variety of designs. **FIG. 4** depicts one embodiment of the disclosed device. In this embodiment, connector **200** comprises a rigid angular body having a series of parallel and alternating ridges and grooves designed to overlay a portion of a horizontal track member of a metal stud frame. A receiving member **230** is shown adjacent leg members **240, 250**. Leg member **240** comprises a pleated or folded edge **245** to accommodate a flashing screw (see **FIG. 6** generally).

In other embodiments, leg member **240** could comprise a straight edge, an arcuate edge, or any desired combination or subcombination, depending on the application for which the device will be used and still fall within the scope and spirit of the disclosure. Furthermore, other configurations of alternating ridges and grooves could be suitable. For example, it is contemplated that the disclosed connector could comprise additional leg members and/or receiving members if desired and still fall within the scope and spirit of the disclosure. Although the cold-forming of steel was implemented in the fabrication of the disclosed device, other manufacturing processes and materials may be suitable depending on the particular application.

Connector **200** comprises edges **210** and **220**. In the configuration shown, connector **200** is mounted at the head of a wall panel. Thus, edge **210** can interface an inner surface of a metal wall panel or other finish material. Edge **220** faces an interior of the building.

FIG. 5 depicts a second connector notated as connector **300**. Because the disclosed device can be fabricated such that the shape of each may be uniform with

another, a connector **200** can be positioned as a connector **300** simply by rearranging or reversing its position. Connector **300** comprises a rigid angular body having a series of parallel and alternating ridges and grooves. As shown in **FIG. 5**, connector **200** may receive a connector **300**, wherein the pair mates to engage one another independent of
 5 fasteners. By rearranging or reversing one of a pair of connectors and mating the respective units, a user can readily interlock a pair of connectors for use with a metal wall panel system.

Referring again to **FIG. 4**, connector **200** may be mounted to overlay a portion of a horizontal track member **110** and be fastened to a vertical stud **130** (see **FIG. 2**) by any
 10 known means. For example, connector **200** could be welded to the stud if desired, however, other suitable fastening means could be utilized. It is contemplated that one or more connectors **200** can be affixed to a respective length of a horizontal track member to facilitate the ease of installing a number of exterior wall panels in series. It is also contemplated that one or more connectors **200** could be used with a single wall panel if
 15 desired.

As shown in **FIG. 5**, receiving member **230** may receive a leg member **340** of an adjacent connector. Correspondingly, receiving member **330** may receive a leg member **240** of an adjacent connector. Thus, a horizontal joint can be formed along a portion of a horizontal track member when a pair of adjacent connectors is engaged. As stated above,
 20 leg members **240, 340** are shown to have a pleated or folded edge. However, the leg members of the disclosed device could comprise a straight edge, an arcuate edge, or any desired combination depending on the application for which the device will be used. In the configuration shown, edges **210, 320** interface an inner surface of a metal wall panel or other finish material. Edges **220, 310** are exposed to an interior of the building.
 25 Connector **300** can be mounted at the sill portion of a wall panel. In cases where a series of connectors **200** are implemented, one or more corresponding connectors **300** could be used.

FIG. 6 depicts a pair of mateable connectors **200, 300** and capable of being affixed to a respective wall panel **260, 360**. Any number of suitable types of panels,

sealant, flashing, insulation, and fasteners may be utilized in conjunction with the disclosed device as necessitated by the particular building envelope project and as would be known to a skilled artisan. For example, an air seal **400** could be installed in receiving member **330** and adjacent an end of leg member **240**. A wide variety of designs may also
5 be used to prevent water leakage for metal panel systems including face sealed barrier systems, weeped drainage systems, and rainscreens. For example, an end dam **500** could be installed to help seal a wall panel for use as a gutter from which condensation buildup within the stud cavity may weep through one or more weep holes (not shown). Such an installation can act as a secondary or incidental system of water relief for finishes
10 attached directly to the metal stud face of the wall panel.

A first level wall panel can either be anchored to a first floor (or bulkhead) or hung from an overlying floor. Consecutive wall panels can be hung from a respective overlying floor to engage an underlying panel by means of the disclosed device. In addition, the disclosed device can be used in conjunction with a series of wall panels
15 hung along the length of a horizontal track member.

Thus, the disclosed device **1000** provides for a wall system comprising: a first connector mounted to a head portion of a respective wall panel, wherein said wall panel is anchored to a floor to accommodate one or more structural loads; said first connector comprising at least one receiving member to receive a leg of a second connector; said
20 second connector mounted to a sill portion of a respective wall panel; and wherein a horizontal joint is formed when said receiving member of said first connector and said leg of said second connector are engaged. Alternately, the disclosed device **1000** provides for a wall panel system comprising: a first connector mounted to a head portion of a respective wall panel, wherein said wall panel is mounted to a base; said first connector
25 comprising at least one receiving member to receive a leg of a second connector; said second connector mounted to a sill portion of a respective wall panel; and wherein a horizontal joint is formed when said receiving member of said first connector and said leg of said second connector are engaged.

The disclosed device also provides for a first connector mountable to a horizontal track member, said first connector capable of being fastened to a vertical stud of a metal framing system; said first connector further comprising at least one receiving member to receive a leg member of an adjacent connector; said adjacent connector further
5 comprising a receiving member to receive a leg member of said first connector; and wherein a horizontal joint is formed when said first connector and said adjacent connector are engaged.

As stated above, metal wall systems can constitute cladding suitable for installation as an exterior side of a building enclosure. Thus, metal panel systems are
10 typically considered to be nonstructural elements that are used to form a curtain wall. Nonetheless, these nonstructural elements are typically engineered to support gravity, seismic and wind loading. Not only should loads from the panels be transmitted to the building's structural frame, the panels should allow thermal movements and be designed so as not to restrain the building's structural system as it deforms under lateral and gravity
15 loads.

Although the disclosed device may be used in conjunction with non-structural metal panels, the disclosed system can enhance both the structural or non-structural components of the building envelope by its ability to control interstory drift, or the shifting of floors relative to one another when a building undergoes wind or earthquake
20 loading. By supporting the horizontal track members anchored to one or more floor slabs or ceiling joists and forming a corresponding movable horizontal joint, the disclosed device can accommodate drifts by flexing or otherwise moving relative to the drift occurrence. The horizontal joint formed by the disclosed device helps to transfer a floor or roof load to the structural component of a building similar to the load transfer by the
25 horizontal track members. Thus, the disclosed device can be beneficial in meeting design requirements in seismic zones. The disclosed device can also be useful in accommodating building movements or deflection attributed to live loads.

As stated above, the disclosed device can be utilized in either a unitized application or a stick built application. Further, the disclosed device could also be used in conjunction with non-metal framing systems if applicable.

Although the disclosed device and method have been described with reference to
5 disclosed embodiments, numerous modifications and variations can be made and still the result will come within the spirit and scope of the disclosure. No limitation with respect to the specific embodiments disclosed herein is intended or should be inferred.

I CLAIM:

1. A connector for use with a metal wall panel system, said connector comprising:
5 a pair of rigid angular bodies each having at least one leg element and one receiving member;
said pair of bodies capable of being mated one with the other when a leg element of said first body interlocks a corresponding receiving member of said second body; and
10 said first body capable of overlaying a portion of a horizontal track member of a metal stud frame.
2. The connector of claim 1, wherein said leg element further comprises a pleated edge.
3. A wall panel system comprising:
15 a first connector mountable to a head portion of a respective wall panel;
wherein said wall panel is mounted to a base;
said first connector comprising at least one receiving member to receive a leg of a second connector;
said second connector mounted to a sill portion of a respective wall panel; and
20 wherein a horizontal joint is formed when said receiving member of said first connector and said leg of said second connector are engaged one with another.
4. The system of claim 3, wherein said base further comprises to a floor to accommodate one or more structural loads.
- 25 5. The system of claim 3, wherein said base further comprises an overlying floor.
6. A connection system for panelized wall cladding, said system comprising:
a first connector mountable to a horizontal track member of a frame, said first connector capable of being fastened to a vertical stud of said frame;

said first connector further comprising at least one receiving member to receive
a leg member of an adjacent connector;

said adjacent connector further comprising a receiving member to receive a leg
member of said first connector; and

5 wherein a horizontal joint is formed contiguous with said horizontal track
member when said first connector and said adjacent connector are
engaged one with another.

7. The system of claim 6, wherein said first or said adjacent connector
comprises a metal plate bent to a desired profile.

10 8. The system of claim 6, wherein said horizontal joint is capable of
transferring one or more building loads.

9. The system of claim 6, wherein said first or said adjacent connector is
capable of being affixed to a portion of a respective wall panel.

15 10. The system of claim 6 further comprising one or more exterior finish
products capable of being preinstalled off-site or applied in situ.

11. The system of claim 10, wherein said one or more exterior finish products
comprise metal, stucco, tile, and/or brick.

12. The system of claim 6 further comprising one or more air seals.

13. The system of claim 6 further comprising one or more weeped drainage
20 systems.

14. A method of constructing a metal wall panel system, said method
comprising:

25 providing a first connector capable of being mounted to a portion of a
horizontal track of a building frame, said first connector fastenable to a
vertical stud of said building frame, said first connector further being
fastenable to a head portion of a wall panel;

positioning a receiving of a second connector to receive a leg member of said
first connector, said second connector fastenable to a sill portion of a
wall panel; and

mating said first and second connectors one to another independent of fasteners.

15. The method of claim 14, wherein said mating step further comprises forming a horizontal joint along said portion of said horizontal track, said horizontal joint
5 capable of transferring one or more building loads.

16. The method of claim 14 further comprising the step of mounting a series of first and second connectors along a length of said a horizontal track member, thereby facilitating the mounting of a series of respective wall panels.

17. The method of claim 14 further comprising the step of anchoring a first
10 level wall panel to a first floor.

1 / 4

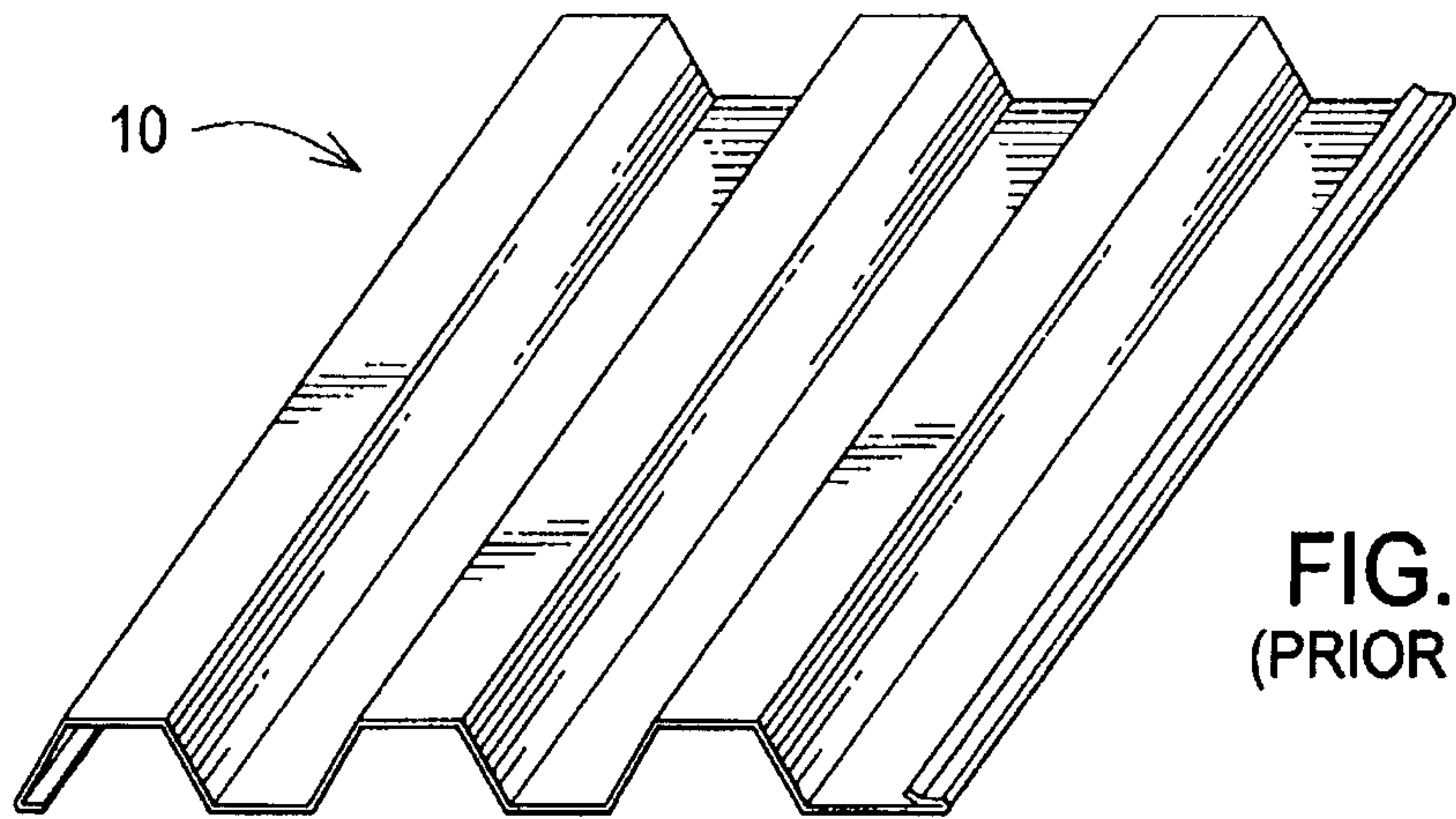

FIG. 1A
(PRIOR ART)

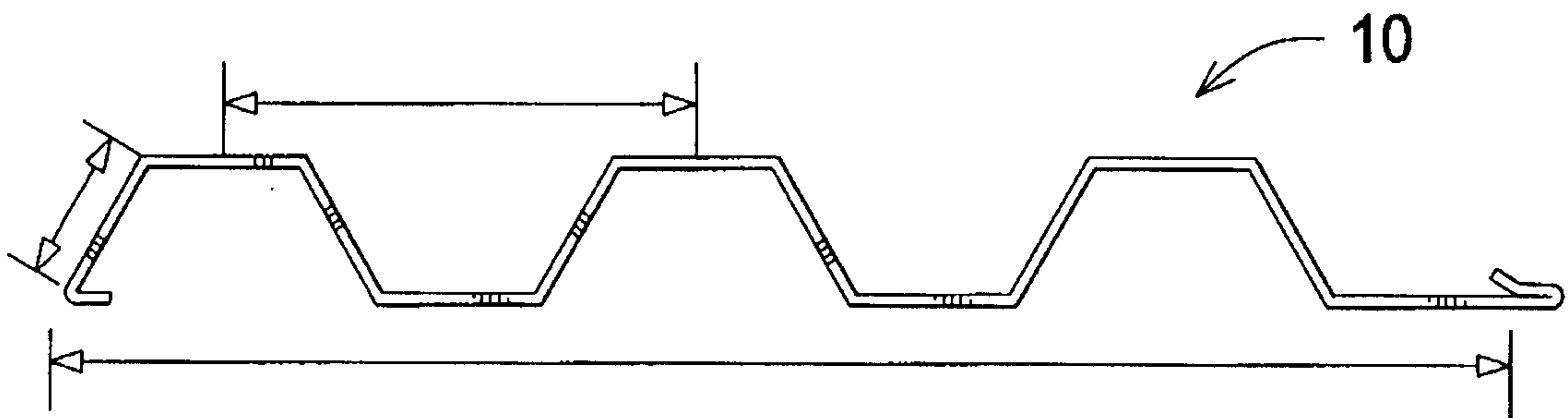

FIG. 1B
(PRIOR ART)

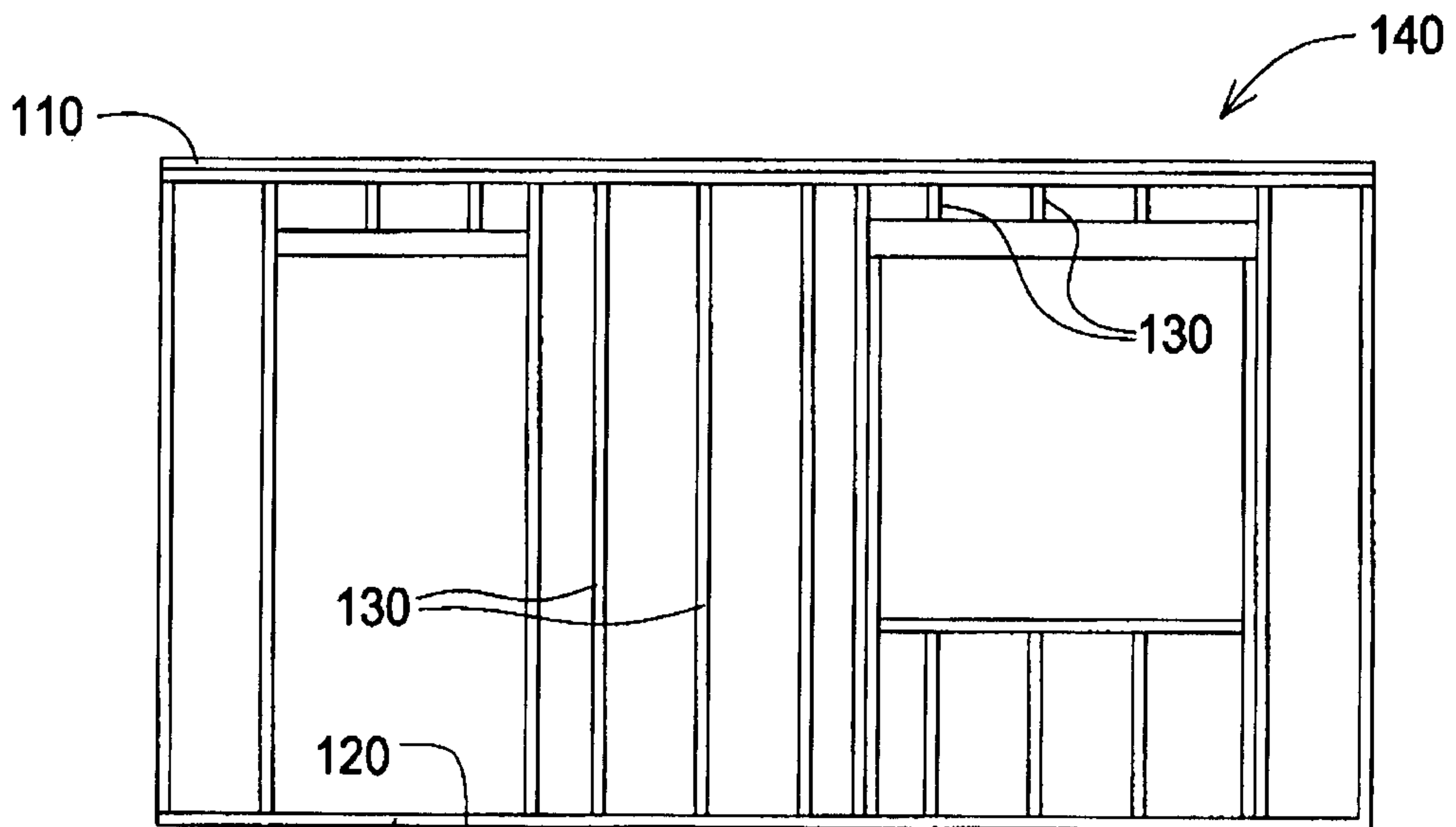

FIG. 2
(PRIOR ART)

2/4

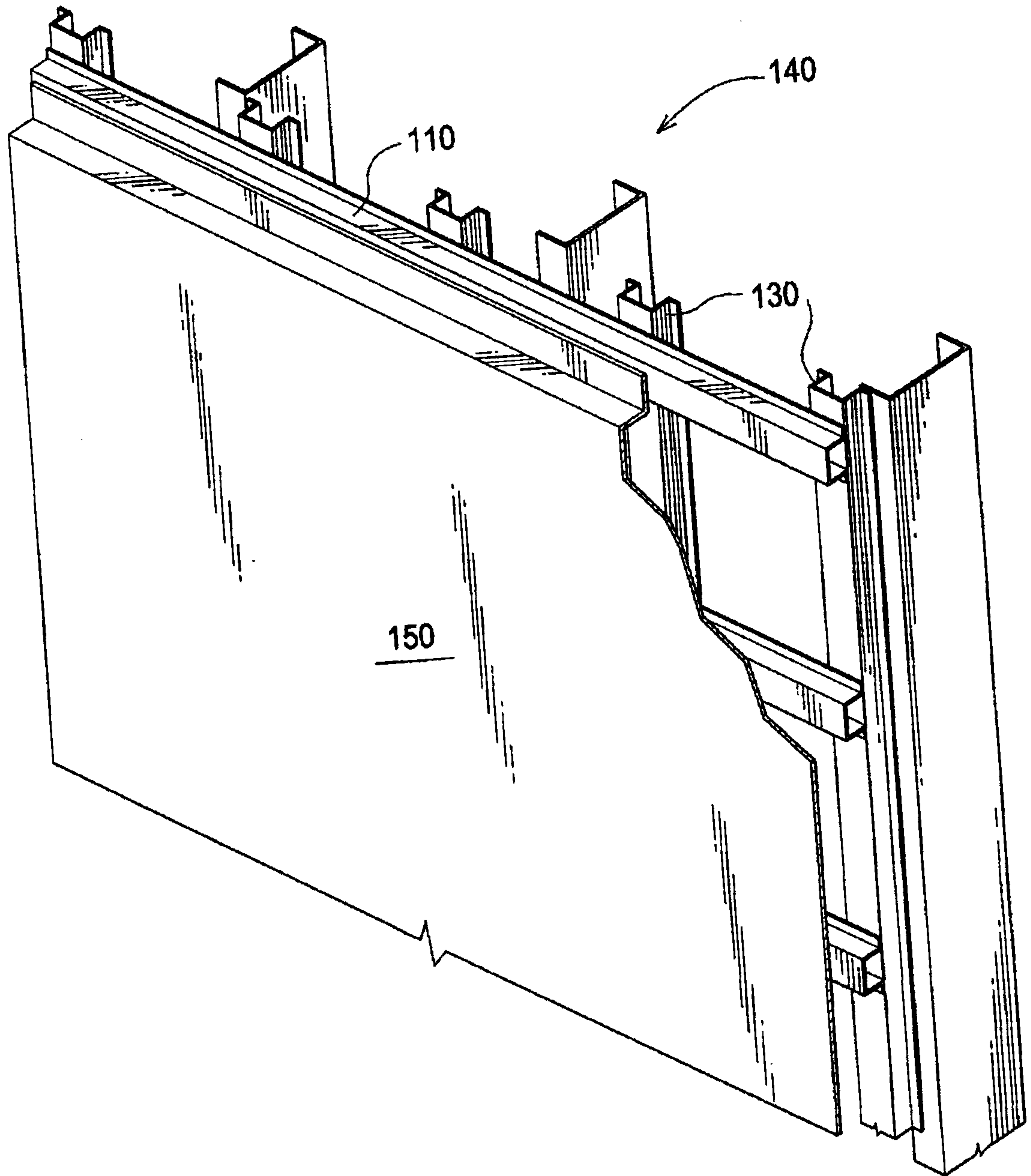

FIG.3
(PRIOR ART)

3/4

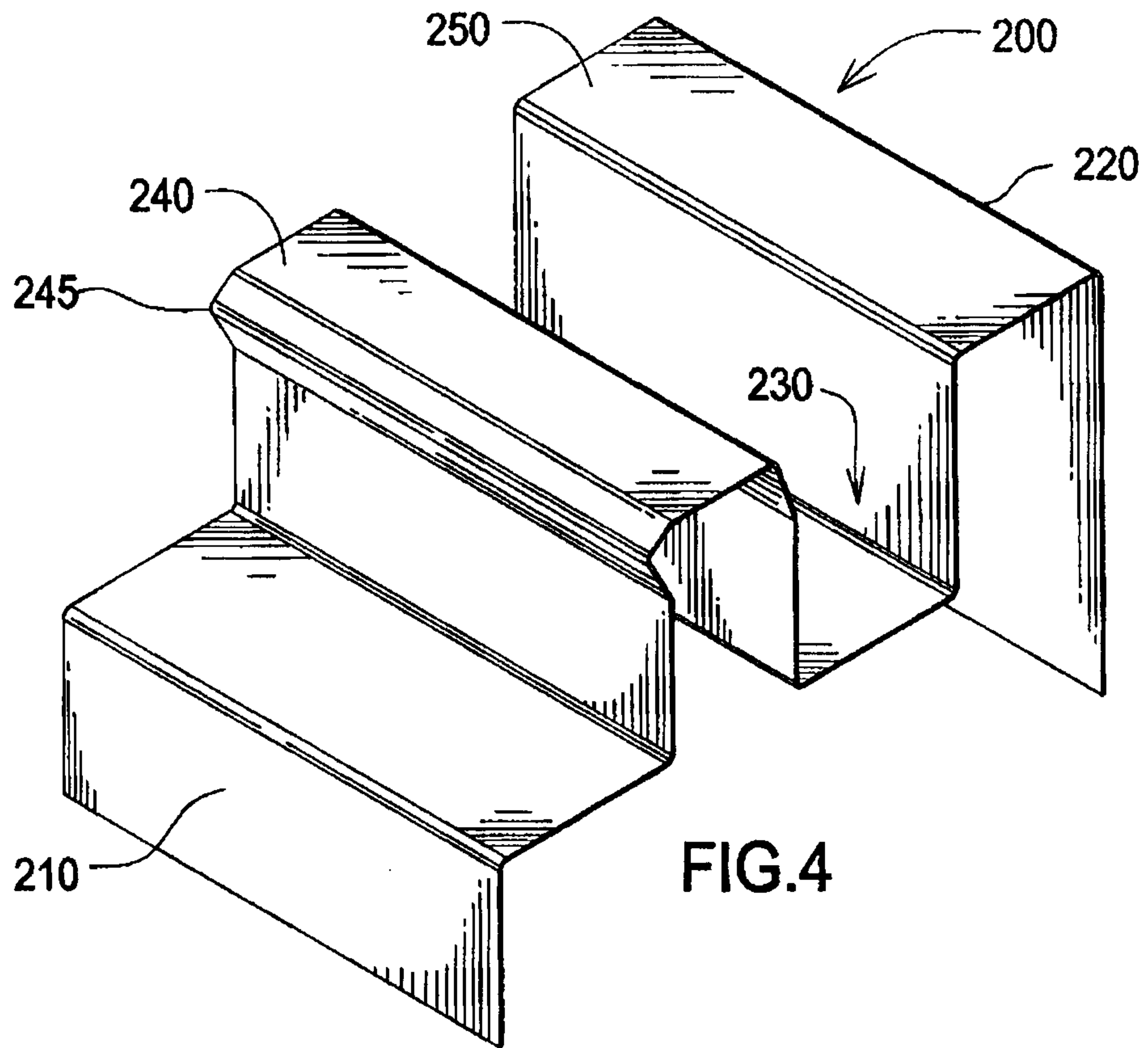

FIG. 4

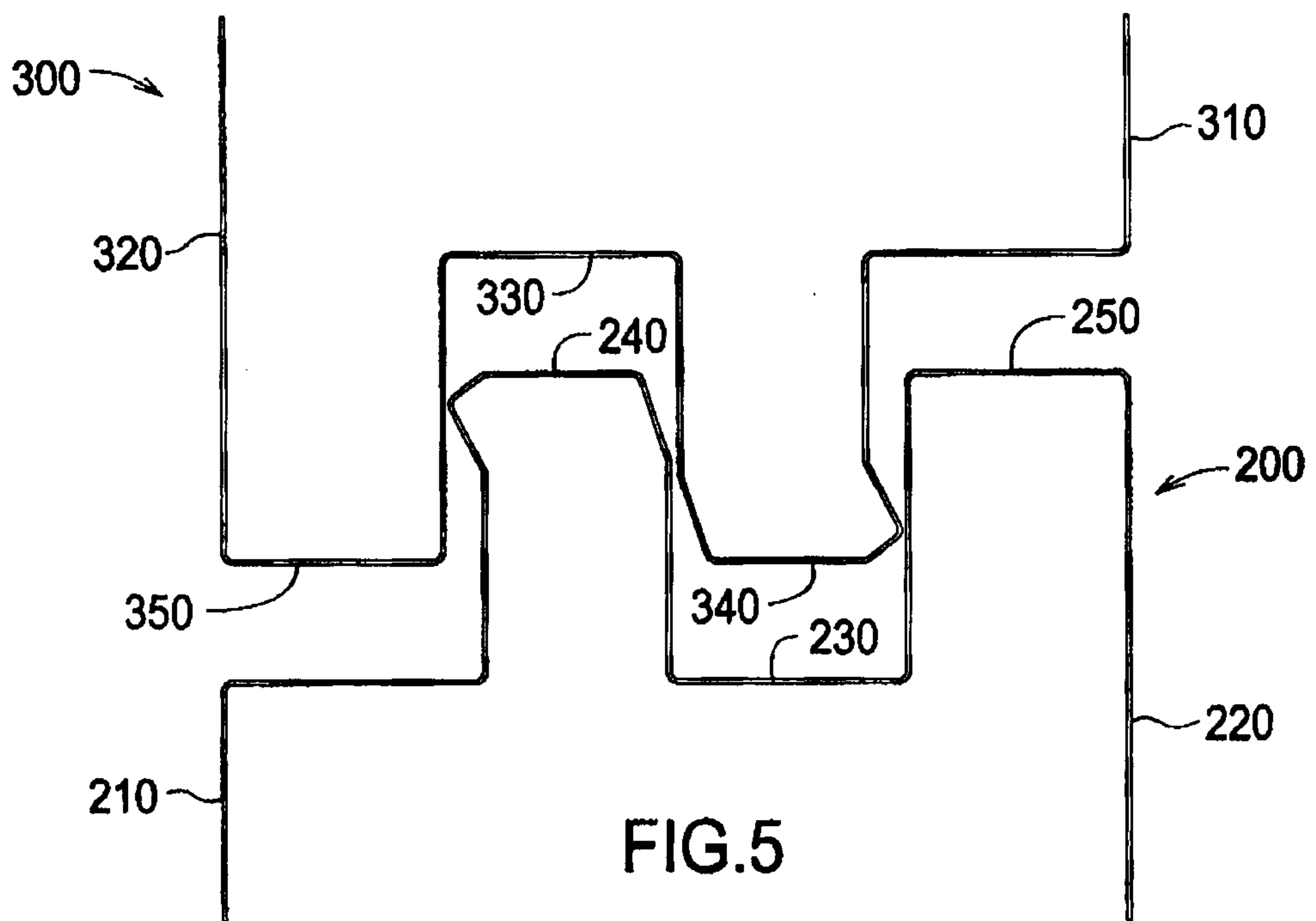

FIG. 5

└

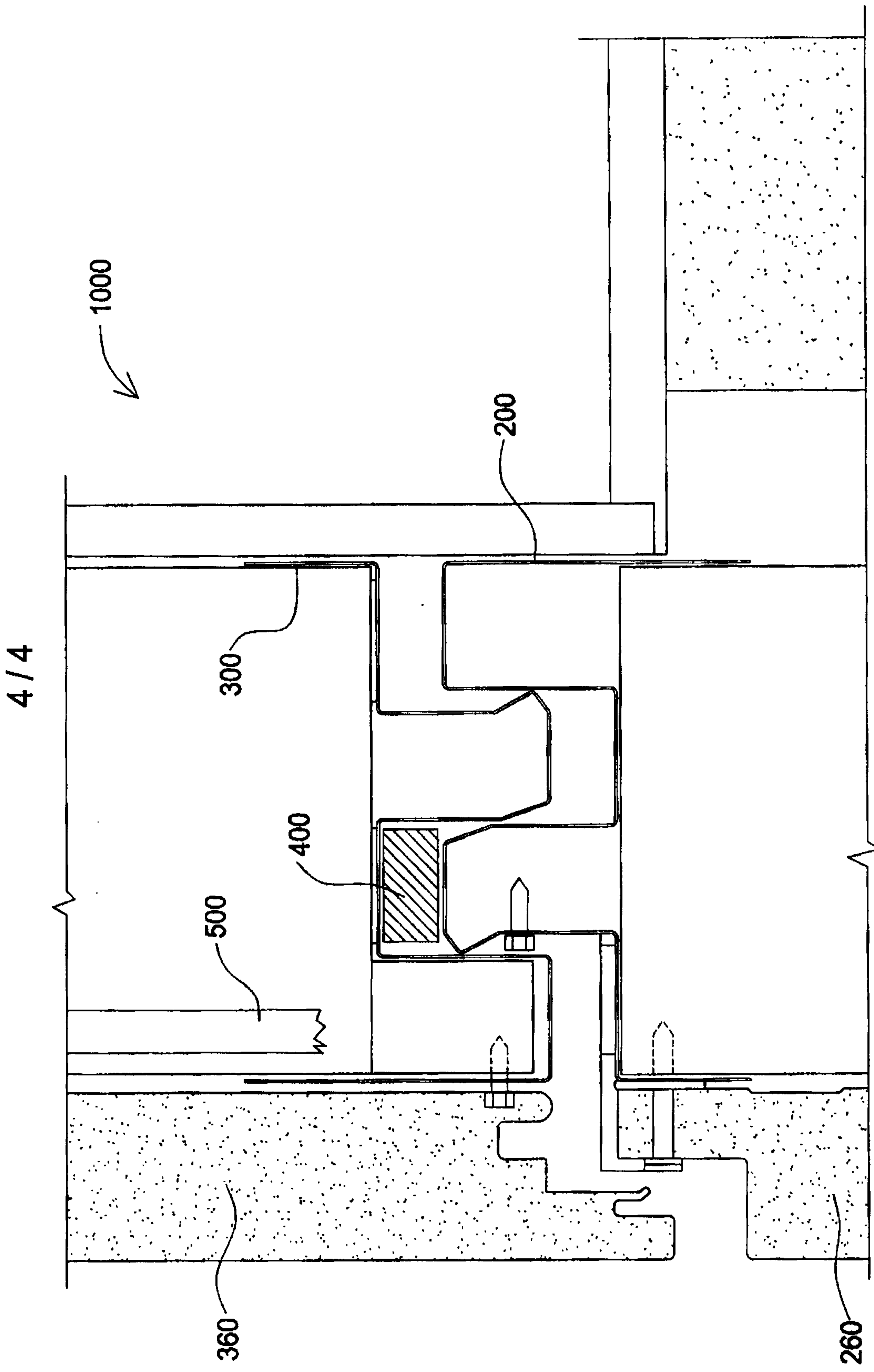

FIG.6

└

