



- (51) International Patent Classification:  
*B01L 3/00* (2006.01)
- (21) International Application Number:  
PCT/EP2013/059692
- (22) International Filing Date:  
9 May 2013 (09.05.2013)
- (25) Filing Language:  
English
- (26) Publication Language:  
English
- (30) Priority Data:  
61/644,858 9 May 2012 (09.05.2012) US  
13/837,007 15 March 2013 (15.03.2013) US
- (71) Applicant: **STAT-DIAGNOSTICA & INNOVATION, S.L.** [ES/ES]; Baldiri Reixac 4, E-08028 Barcelona (ES).
- (72) Inventors; and
- (71) Applicants : **BRU GIBERT, Rafael** [ES/ES]; Stat-Diagnostica & Innovation, S.L., Baldiri Reixac 4, E-08028 Barcelona (ES). **CARRERA FABRA, Jordi** [ES/ES]; Stat-Diagnostica & Innovation, S.L., Baldiri Reixac 4, E-08028 Barcelona (ES). **COMENGENS CASES, Anna** [ES/ES]; Stat-Diagnostica & Innovation S.L, Baldiri Reixac 4, E-08028 Barcelona (ES). **GARCÍA SÁNCHEZ, José Antonio** [ES/ES]; Stat-Diagnostica & Innovation S.L, Baldiri Reixac 4, E-08028 Barcelona (ES).

- (74) Agent: **PRIETO MORÁN, Fernando**; ABG Patentes, S.L., Avenida de Burgos 16D, Edificio Euromor, E-28036 Madrid (ES).
- (81) Designated States (unless otherwise indicated, for every kind of national protection available): AE, AG, AL, AM, AO, AT, AU, AZ, BA, BB, BG, BH, BN, BR, BW, BY, BZ, CA, CH, CL, CN, CO, CR, CU, CZ, DE, DK, DM, DO, DZ, EC, EE, EG, ES, FI, GB, GD, GE, GH, GM, GT, HN, HR, HU, ID, IL, IN, IS, JP, KE, KG, KM, KN, KP, KR, KZ, LA, LC, LK, LR, LS, LT, LU, LY, MA, MD, ME, MG, MK, MN, MW, MX, MY, MZ, NA, NG, NI, NO, NZ, OM, PA, PE, PG, PH, PL, PT, QA, RO, RS, RU, RW, SC, SD, SE, SG, SK, SL, SM, ST, SV, SY, TH, TJ, TM, TN, TR, TT, TZ, UA, UG, US, UZ, VC, VN, ZA, ZM, ZW.
- (84) Designated States (unless otherwise indicated, for every kind of regional protection available): ARIPO (BW, GH, GM, KE, LR, LS, MW, MZ, NA, RW, SD, SL, SZ, TZ, UG, ZM, ZW), Eurasian (AM, AZ, BY, KG, KZ, RU, TJ, TM), European (AL, AT, BE, BG, CH, CY, CZ, DE, DK, EE, ES, FI, FR, GB, GR, HR, HU, IE, IS, IT, LT, LU, LV, MC, MK, MT, NL, NO, PL, PT, RO, RS, SE, SI, SK, SM, TR), OAPI (BF, BJ, CF, CG, CI, CM, GA, GN, GQ, GW, ML, MR, NE, SN, TD, TG).

[Continued on next page]

(54) Title: PLURALITY OF REACTION CHAMBERS IN A TEST CARTRIDGE

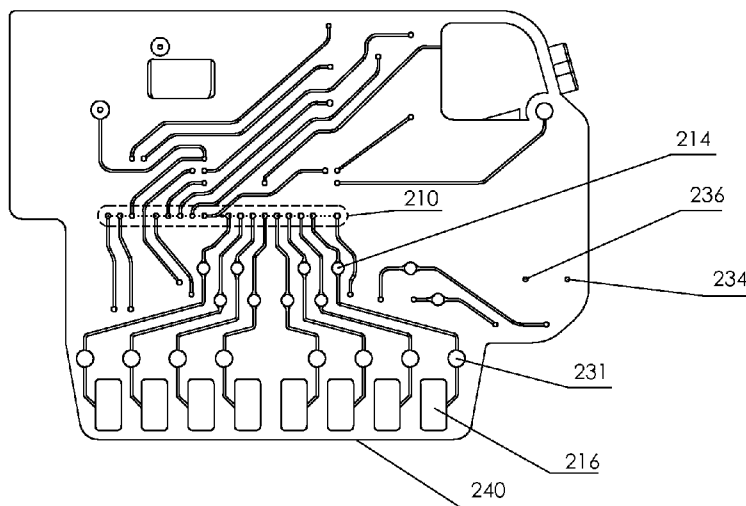

Fig. 2

(57) Abstract: A fluidic testing system is presented that includes a plurality of test chambers, a plurality of inlet channels, and a fluidic network that connects the inlet channels to one or more other chambers. The plurality of test chambers are each characterized by a length and a hydraulic diameter. The length of each test chamber is aligned substantially parallel to a gravity vector. Each of the test chambers has only one opening disposed along the length of the corresponding test chamber. Additionally, each of the test chambers is coupled via its respective opening to only one of the plurality of inlet channels.

WO 2013/167716 A2

**Published:**

- *without international search report and to be republished upon receipt of that report (Rule 48.2(g))*

## PLURALITY OF REACTION CHAMBERS IN A TEST CARTRIDGE

## BACKGROUND

## Field

[0001] Embodiments of the present invention relate to the field of clinical  
5 diagnostic tools.

## Background

[0002] Given the complexity of the automation of molecular testing and  
immunoassay techniques, there is a lack of products that provide adequate  
performances to be clinically usable in near patient testing settings. Typical  
10 molecular testing includes various processes involving the correct dosage of  
reagents, sample introduction, lysis of cells to extract DNA or RNA, purification  
steps, and amplification for its subsequent detection. Even though there are  
central laboratory robotic platforms that automate some of these processes, for  
many tests requiring a short turnaround time, the central laboratory cannot  
15 provide the results in the needed time requirements.

[0003] However, it is difficult to implement systems in a clinical setting that  
provide accurate, trustworthy results at a reasonable expense. Given the  
complicated nature of various molecular testing techniques, the results are prone  
to error if the testing parameters are not carefully controlled or if the  
20 environmental conditions are not ideal. For example, existing instrumentation  
for PCR techniques has experienced high entry barriers for clinical diagnosis  
applications due to the background generated by exogenous sources of DNA. In  
the case of specific tests of pathogens, the predominant source of contamination  
is a result of previous reactions carried out in pipettes, tubes, or general  
25 laboratory equipment. Additionally, the use of molecular techniques for  
detection of microbial pathogens can produce false negatives. The false  
negatives may result from, for example: improper disposal of agents that inhibit  
the Polymerase Chain Reaction (PCR) such as hemoglobin, urine or sputum;  
inefficient release of DNA from cells; or low efficiency in extraction and  
30 purification of DNA or RNA.

**[0004]** The fact that molecular techniques have exceptional sensitivity levels at concentrations lower than the previous reference methods makes it rather difficult to obtain clinically relevant conclusions, while avoiding erroneous calls with false positives. To minimize this problem, especially for the detection of pathogen microorganisms, tests should have quantification capability. It has therefore become increasingly necessary to perform multiplexed assays and arrays of tests to consolidate enough data to make confident conclusions. As an example, one of the main limitations of existing PCR-based tests is the inability to perform amplifications of different target genes simultaneously. While techniques such as microarrays provide very high multiplexing capacity, their main limitation is the low speed in obtaining the results, which often have no positive impact on patient management.

**[0005]**

## BRIEF SUMMARY

15 **[0006]** A fluidic testing system which includes a plurality of test chambers is presented. Simultaneous fluid control of each testing site can reduce testing time and enhance the probability of obtaining repeatable results among the various testing sites.

20 **[0007]** In an embodiment, a single-port fluidic testing system includes a plurality of test chambers, each characterized by a length and a hydraulic diameter. Each of the plurality of test chambers has only one opening disposed along the length of the corresponding test chamber. The fluidic testing system further includes a first inlet channel and a plurality of fluid splitting elements. The fluid splitting elements split an initial liquid flowing down the first inlet channel into a plurality of second inlet channels. Each of the plurality of test chambers is coupled via its respective opening to only one of the plurality of second inlet channels.

25 **[0008]** An example method is described. The method includes flowing an initial amount of liquid down a first inlet channel of a single-port fluidic testing system. The initial amount of liquid is split into a plurality of second inlet channels, each second inlet channel coupled to a plurality of test chambers,

30

wherein each of the plurality of test chambers has only one opening disposed along a length of the chamber. The method further includes filling each of the test chambers with a final amount of liquid, the final amount being substantially equal in each of the test chambers and summing from each test chamber to equal  
5 the initial amount of liquid.

**[0009]** In another embodiment, a fluidic testing system includes a plurality of test chambers, a plurality of inlet channels, and a fluidic network that connects the inlet channels to one or more other chambers. The test chambers each have a length and a hydraulic diameter. The length of each test chamber is aligned  
10 substantially parallel to a gravity vector. Each of the test chambers has only one opening disposed along the length of the corresponding test chamber. Additionally, each of the test chambers is coupled via its respective opening to only one of the plurality of inlet channels.

**[0010]** Another example method is described. The method includes flowing  
15 liquid through a plurality of inlet channels, each inlet channel coupled to a plurality of test chambers. A length of each test chamber is aligned substantially parallel to a gravity vector, and each of the test chambers has only one opening disposed along the length of the chamber. The method further includes filling each of the plurality of test chambers with the liquid up to a threshold amount.  
20 The method further includes drawing the liquid away from each of the test chambers through the inlet channels to leave behind a predetermined amount of the liquid within each test chamber.

**[0011]** Another example method is described. The method includes flowing a  
25 first liquid through a first inlet channel coupled to a first opening disposed along a length of a test chamber at a first height. The length of the test chamber is aligned substantially parallel to a gravity vector. The method further includes filling the test chamber with the first liquid up to a first threshold amount. The first liquid is drawn away from the test chamber through the first inlet channel, and leaves behind a first predetermined amount of the first liquid within the test  
30 chamber. The method further includes flowing a second liquid through a second inlet channel coupled to a second opening disposed along the length of the test chamber at a second height. The second height is greater than the first height.

The method further includes filling the test chamber with the second liquid up to a second threshold amount. The second liquid is drawn away from the test chamber through the second inlet channel, and leaves behind a second predetermined amount of the second liquid within the test chamber.

5 [0012] Another example method is described. The method includes flowing liquid through each of a plurality of channels up to a liquid sensing area disposed in each channel, thus setting a pre-determined amount of liquid within each of the plurality of channels. The method further includes flowing only the pre-determined amount of liquid within each of the plurality of channels into  
10 respective chambers coupled to each of the channels.

### BRIEF DESCRIPTION OF THE DRAWINGS/FIGURES

[0013] The accompanying drawings, which are incorporated herein and form a part of the specification, illustrate embodiments of the present invention and, together with the description, further serve to explain the principles of the  
15 invention and to enable a person skilled in the pertinent art to make and use the invention.

[0014] FIG. 1 is a graphical representation of a test cartridge system, according to an embodiment.

[0015] FIG. 2 displays a side view of the test cartridge system, according to an  
20 embodiment.

[0016] FIG. 3 illustrates a test chamber, according to an embodiment.

[0017] FIGs. 4A-C illustrate operation of the test chamber, according to an embodiment.

[0018] FIG. 5 illustrates a plurality of test chambers, according to an  
25 embodiment.

[0019] FIGs. 6A-C illustrate another operation of the test chamber, according to an embodiment.

[0020] FIG. 7 illustrates another test chamber, according to an embodiment.

[0021] FIG. 8 illustrates another plurality of test chambers, according to an  
30 embodiment.

[0022] FIG. 9 illustrates another plurality of test chambers, according to an embodiment.

[0023] FIG. 10 illustrates the test cartridge system within an analyzer, according to an embodiment.

5 [0024] FIGs. 11-14 illustrate example chamber filling methods, according to embodiments.

[0025] Embodiments of the present invention will be described with reference to the accompanying drawings.

10

## DETAILED DESCRIPTION

[0026] Although specific configurations and arrangements are discussed, it should be understood that this is done for illustrative purposes only. A person skilled in the pertinent art will recognize that other configurations and arrangements can be used without departing from the spirit and scope of the present invention. It will be apparent to a person skilled in the pertinent art that this invention can also be employed in a variety of other applications.

15 [0027] It is noted that references in the specification to "one embodiment," "an embodiment," "an example embodiment," etc., indicate that the embodiment described may include a particular feature, structure, or characteristic, but every embodiment may not necessarily include the particular feature, structure, or characteristic. Moreover, such phrases do not necessarily refer to the same embodiment. Further, when a particular feature, structure or characteristic is described in connection with an embodiment, it would be within the knowledge of one skilled in the art to effect such feature, structure or characteristic in connection with other embodiments whether or not explicitly described.

20 [0028] Embodiments described herein relate to a test cartridge system for performing a variety of molecular tests, such as immunoassays, PCR, DNA hybridization, etc. In an embodiment, the test cartridge integrates all of the components necessary to perform such tests into a single, disposable package.

25

30 The test cartridge may be configured to be analyzed by an external measurement system which provides data related to the reactions that take place within the test

cartridge. In an embodiment, the test cartridge includes a plurality of test chambers with a transparent window to perform optical detection with each test chamber.

5 [0029] In one example, a single test cartridge may be used to perform an array of immunoassays with a given sample. The test cartridge contains all of the necessary buffers, reagents, and labels held in sealed chambers integrated into the cartridge to perform the immunoassays.

10 [0030] In another example, a single test cartridge may be used to perform PCR. The DNA may be purified from the rest of a sample via a filter incorporated into the test cartridge. The sample may be extruded through the filter while a separately stored elution liquid may remove the DNA and bring it into another chamber to begin the process of temperature cycling.

15 [0031] One of the main limitations of molecular diagnostic instrumentation is the problem associated with contamination such as cross-contamination, carry-over contamination, etc. Embodiments described herein substantially eliminate by design the contamination of samples to the instrument.

20 [0032] In one embodiment, the test cartridge offers a self-contained liquid sealed during the manufacturing process. The reagents and the sample do not enter into contact with the environment or with any part of the instrument. This feature of the test cartridge is also important for many laboratories and hospitals to safely dispose of the products after their use.

25 [0033] In order to perform an array of tests, the test cartridge contains a plurality of test chambers designed to facilitate measuring optical properties of the contents within each test chamber, according to an embodiment. For example, the test chambers each contain a transparent window to allow for either fluorescence or absorbance studies of the contents therein. Additionally, the design of the fluidic arrangement to each test chamber may allow for each chamber to be filled to the same level while using a single pump source.

30 [0034] Further details relating to the components of the test cartridge system, including the test chambers, are described herein with references made to the figures. It should be understood that the illustrations of each physical component are not meant to be limiting and that a person having skill in the relevant art(s)

given the description herein would recognize ways to re-arrange or otherwise alter any of the components without deviating from the scope or spirit of the invention.

5 [0035] FIG. 1 illustrates an example test cartridge system 100 with an array of test chambers, according to an embodiment. Although reference will be made herein to the structure of example test cartridge system 100, one of skill in the art will recognize that test chamber embodiments described herein may be used with any number of testing system types and configurations.

10 [0036] Test cartridge system 100 includes a cartridge housing 102. Other components may be considered as well for inclusion in test cartridge system 100, such as an analyzer module or various active components such as pumps or heaters.

15 [0037] Cartridge housing 102 includes a variety of fluidic channels, chambers, and reservoirs. For example, cartridge housing 102 may include a plurality of storage chambers 116 which may contain various buffers or other reagents to be used during an assay or PCR protocol. Storage chambers 116 may be pre-filled with various liquids so that the end user will not need to fill storage chambers 116 before placing test cartridge system 100 into an analyzer. In another example, the reagents are freeze-dried before being placed in storage chambers 20 116. Cartridge housing 102 may further include one or more processing chambers 124a-b connected to fluidic channels along a side of cartridge housing 102. Processing chambers 124a-b may be used for a variety of processing and/or waste applications.

25 [0038] Samples are introduced into cartridge housing 102 via sample port 114, according to an embodiment. In an example, sample port 114 receives solid, semi-solid, or liquid samples. In another embodiment, cartridge housing 102 includes more than one inlet to introduce samples.

30 [0039] The various chambers and channels around cartridge housing 102 may be sealed via the use of covers 118, 126, 127, and 128. The covers may be films capable of sealing the fluid within cartridge housing 102. In another example, the covers may be plastic panels. In an example, one or more of the covers are

transparent. Additionally, one or more of the covers may be thermally controlled for heating portions of housing 102.

[0040] The integrated test cartridge system 100 allows a user to place a sample into, for example, sample port 114, then place test cartridge system 100 into an analyzer. In embodiments, the reaction steps to be performed including, for example, purification, lysing, mixing, binding, labeling and/or detecting can all be performed within test cartridge system 100 via interaction with the analyzer without any need for the end user to intervene. Additionally, since all of the liquids remain sealed within test cartridge system 100, after the test is completed, test cartridge system 100 may be removed from the analyzer and safely disposed of without contamination of the analyzer.

[0041] FIG. 2 illustrates a side view of cartridge housing 102, according to an embodiment. The description of cartridge housing 102 is set forth to describe features that may be present on cartridge housing 102, but should not be limiting as to the placement or dimensional properties of the features.

[0042] FIG. 2 illustrates a fluidic network and a series of ports which extend into cartridge housing 102. The fluidic network may connect to one or more of storage chambers 116 and/or processing chambers 124a-b of cartridge housing 102. These chambers may be disposed on the opposite side of cartridge housing 102 from the side illustrated in FIG. 2. In an embodiment, the fluidic network also connects to a series of test chambers 216.

[0043] Each fluidic channel may also be designed to terminate at a port which will interface with the ports or valve regions on a moveable transfer module (not shown) within housing 102. A plurality of ports 210 allow fluid to flow to any chamber of housing 102, according to an embodiment. Plurality of ports 210 may act as either inlet ports for liquid to be drawn into an inner chamber within cartridge housing 102, or as outlet ports for liquid to be expelled from the inner chamber to the fluidic network of cartridge housing 102. For example, liquid may be pressurized to flow through the second to the right port of liquid ports 210 and down into the far right test chamber 216. Furthermore, liquid may be drawn back from the far right test chamber 216 and into the second to the right port of liquid ports 210 via an applied vacuum pressure.

[0044] Test chambers 216 may be shaped similarly, for example, to a centrifuge tube. In one embodiment, liquid may be drawn into test chambers 216 to mix with reagents that have been pre-loaded into each test chamber. For example, each test chamber may be loaded with different primers and probes for a PCR process, and liquid may be drawn into each test chamber to create distinct mixtures in each chamber. The reagents may be freeze-dried before being loaded into test chambers 216. In another embodiment, test chambers 216 are also used for sample detection. Detection may occur using an external optical source and photodetector coupled to an analyzer in which test cartridge system 100 is placed. Thus, any walls or covers of test chambers 216 may be transparent to allow for optical detection. In one example, the photodetector measures absorbance through the liquid within the test chamber at one or more wavelengths. In another example, the photodetector measures a fluorescence signal generated from a fluorescent compound within the test chamber. In an embodiment, the fluorescence measurements are taken from beneath test chambers 216. Test chambers 216 may be adapted for other means of detection, e.g., electrochemical, electromechanical, surface plasmon resonance, etc.

[0045] A set of smaller channel enlargements 214 are observed upstream from test chambers 216, according to an embodiment. Channel enlargements 214 may act as liquid sensing areas. As such, channel enlargements 214 may be used along with an external optical probe to determine whether or not liquid is present within channel enlargements 214. This determination may be used to activate other functions of test cartridge system 100. In another embodiment, channel enlargements 214 may include integrated sensors, such as a patterned resistive sensor, to indicate the presence or flow rate of the fluid. Additionally, the optical signal detected at a particular channel enlargement 214 monitors the presence of liquid within a corresponding test chamber 216.

[0046] The liquid sensing areas in channel enlargements 214 may be used to set pre-determined amounts of liquid to be dosed into each test chamber 216. For example, liquid may be pressurized into each channel separately or simultaneously until the liquid reaches the liquid sensing areas in each channel. In this way, each channel may contain substantially the same amount of liquid

filling the channel up to channel enlargement 214. Afterwards, each channel may be separately or simultaneously pressurized to force the pre-determined amount of liquid down into each test chamber 216, according to some embodiments.

5 [0047] A plurality of premixing chambers 231 may also be disposed upstream from test chambers 216, according to an embodiment. Premixing chambers 231 may include dry chemicals, such as frozen or lyophilized analytes. In another example, premixing chambers 231 include dry chemistry beads or biological samples. The biological samples may be freeze dried within premixing chambers 231. Such biological or chemical compounds may be stored in  
10 premixing chambers 231 for long periods of time before use. The dimensions of premixing chambers 231 may be designed to specifically fit the size of a dry chemistry bead, usually on the order of a few millimeters in diameter, according to one embodiment. In one example, fluid drawn towards reaction chambers  
15 216 mixes with the samples stored in premixing chambers 231.

[0048] At the lower part of cartridge housing 102 in FIG. 2, an optical access area 240 is disposed below test chambers 216, according to an embodiment. Optical access area 240 is designed to be substantially transparent to all wavelengths used during the optical detection process. In one example, each  
20 individual test chamber 216 has its own optical access area. In another example, a single optical access area stretches across multiple test chambers 216.

[0049] Also illustrated on the side of cartridge housing 102 are a pressure port 236 and a vent port 234, according to an embodiment. Pressure port 236 may be connected to an external pressure source for applying either positive or negative  
25 pressure differentials throughout the system, according to an embodiment. Vent port 234 may either be open to the atmosphere or connect to another pressure source. For example, a positive pressure difference may be applied to one port while a negative pressure difference is applied to the other port to force a faster movement of liquid through the coupled channels of the system.

30 [0050] A film or plurality of films may be placed over the series of test chambers 216. The films may be thin enough to still provide adequate sealing while also allowing for easier heating and/or cooling of the contents within test

chambers 216 via an external source. For example, the films may have a surface that is thermally controlled by any one of, or a combination of, thermoelectric devices, resistive heaters, and forced air. In one example, the films are polymeric films having a thickness less than 100 microns. In one example, the thermal conductivity of the films is greater than 1 W/mK.

5 [0051] FIG. 3 illustrates a more detailed view of test chamber 216, according to an embodiment. Test chamber 216 includes a single opening 304 disposed along a length of test chamber 216 that couples to an inlet channel 302. Test chamber 216 also has a curved bottom wall 306. Curved bottom wall 306 may be transparent to allow for optical detection from underneath test chamber 216. 10 Test chamber 216 has a large enough hydraulic diameter that gravity influences the fluid flow within test chamber 216. Thus, test chamber 216 is aligned so that its length is substantially parallel to a gravity vector. Due to this alignment, the liquid is influenced by the forces of gravity and fills the chamber from the bottom up. 15

[0052] Test chamber 216 may contain reagents 308. Any number of reagents may be present within reagents 308. Reagents 308 may be present in liquid form or as a freeze-dried pellet. Reagents 308 are re-suspended within the liquid that flows into test chamber 216. In another example, reagents 308 are stored in 20 premixing chamber 231 to mix with fluid upstream from test chamber 216.

[0053] An inlet channel 302 couples to test chamber 216 via opening 304. Inlet channel 302 may be one channel of a plurality of channels integrated within cartridge housing 102. Inlet channel 302 provides a fluid path for liquid to flow into test chamber 216 and be drawn from test chamber 216.

25 [0054] In an embodiment, opening 304 is wider than the width of inlet channel 302. The wider opening provides a more controlled entry of liquid into test chamber 216 and also reduces the size of the droplet created by the liquid as it enters into test chamber 216 through opening 304. Each of these factors reduce the probability that the liquid forms a meniscus between the two lateral walls of test chamber 306. The formation of the meniscus makes it difficult to control 30 the amount of liquid within the chamber and causes bubbles to form. The

bubbles can disrupt any biological processes to take place within test chamber 216 and cause errors in the optical measurements.

[0055] An example operation of test chamber 216 is illustrated in FIGs. 4A-C, according to an embodiment. In FIG. 4A, a pre-determined amount of liquid is disposed within inlet channel 302. The pre-determined amount of liquid is  
5 dispensed through opening 304 and into test chamber 216 as illustrated in FIG. 4B. The liquid may be dispensed, for example, via a generated pressure difference.

[0056] In one example, the amount of liquid to be dosed into test chamber 216 is  
10 chosen so that the resulting liquid level is either at or below a height  $h$ , where  $h$  is the distance of opening 304 from the bottom of test chamber 216. The resultant liquid 402 is illustrated in FIG. 4C. As a result, any gas in the top portion of test chamber 216 is free to escape via opening 304.

[0057] Dosing a pre-determined amount of liquid into test chamber 216 allows  
15 the procedure to take place via a single pressurization event. As such, coordinating the filling of multiple test chambers in parallel is simplified.

[0058] FIG. 5 illustrates an example arrangement for a plurality of test chambers  
20 216, according to an embodiment. A single connecting inlet (or port) 502 is illustrated for coupling the various test chambers 216 to the fluidic network of, for example, test cartridge system 100. In an embodiment, single inlet 502 is coupled to a single port where the single port is the only external opening to the fluidic system.

[0059] In the example shown, since only single inlet 502 is provided for dosing  
25 liquid into multiple test chambers 216, the fluidic channels include various channel splitters 504a-c. The geometry of channel splitters 504a-c may be chosen so that half of the incoming liquid flows down one path while the other half flows down the other path. Alternatively, the geometry may be chosen to create any ratio of splitting the liquid between the two resulting channels. The plurality of test chambers 216 need not be aligned straight across as illustrated  
30 but can be arranged in any fashion that keeps the total path lengths between the single inlet 502 and each of the test chambers 216 equal. The equal path lengths

simplify the procedure for dosing controlled amounts of liquid into each test chamber 216.

- 5 [0060] Channel splitters 504a-c assist in providing an equal amount of liquid to dose into each of test chambers 216. For example, 80  $\mu\text{L}$  of liquid may be introduced via single connecting inlet 502. After going through channel splitter 504a, 504b, and 504c in succession, 10  $\mu\text{L}$  of liquid would be dosed into each test chamber 216. Although this example considers that each channel splitter 504a-c is a 50/50 fluid splitter, this does not need to be the case and any ratio of resulting fluid amounts could be realized amongst the test chambers 216.
- 10 [0061] The channel arrangement illustrated in FIG. 5 represents a closed fluidic system that allows for dosing to be more easily implemented via a single pressurization event. For example, a positive pressure applied to single connecting inlet 502 may be used to dose a pre-determined amount of liquid into each of test chambers 216 as described previously with regard to FIGs. 4A-C.
- 15 [0062] FIGs. 6A-C describe an example operation of test chamber 216, according to an embodiment. In FIG. 6A, test chamber 216 is filled with liquid up to a height greater than height  $h$ . A positive pressure may be applied to fill chamber 216 up to this point. In an embodiment, a pressure sensor and/or regulator may be included with the system to control the applied pressure and sense when the liquid has reached a threshold amount.
- 20 [0063] In FIG. 6B, a negative pressure is applied and the liquid is drawn out of test chamber 216 through inlet channel 302. The negative pressure may be applied so that the fluid is drawn out faster than when it flowed into test chamber 216.
- 25 [0064] In FIG. 6C, liquid is drawn out until the liquid level within test chamber 216 drops below height  $h$ . A pre-determined amount 602 of liquid remains within test chamber 216 after the negative pressure is removed. The exact volume of predetermined amount 602 depends on height  $h$  of opening 304, the hydraulic diameter of test chamber 216, and the pressure applied during the drawing of the liquid. Using this procedure, a calculated amount of liquid can
- 30 be dosed into test chamber 216 through only the single inlet channel 302. For example, the amount of liquid left in the chamber may be determined by the

point at which the gravitational force and surface tension on the liquid overcome the negative pressure applied to the channel. In one example, the liquid is drawn out of test chamber 216 quickly enough so that no reagents that may be present within test chamber 216 are drawn back through inlet channel 302. Height  $h$  may be adjusted for various designs of test chamber 216 to adjust the amount of liquid left behind within test chamber 216.

5

**[0065]** FIG. 7 illustrates an embodiment of a multi-channel chamber 702. Two inlet channels 704a-b are coupled to multi-channel chamber 702 via openings 706a-b respectively. Each of openings 706a-b are disposed along a length of multi-channel chamber 702 at a height  $h_1$  and  $h_2$ , respectively.

10

**[0066]** Multi-channel chamber 702 may be used to dose various controlled levels of different liquids within the same chamber. For example, with inlet channel 704b closed off to the atmosphere, a first liquid may flow into multi-channel chamber 702 through inlet channel 704a. A predetermined amount of liquid may be dosed into multi-channel chamber 702 via inlet channel 704a and 704b in succession using a similar process to that described with regard to FIG. 4A-C. In another embodiment, an amount of the first and second liquids is left behind in multi-channel chamber 702 using a similar process to that described with regard to FIGs. 6A-C. The amount of the first liquid left behind may correspond to the height  $h_1$  of first opening 706a. Then, inlet channel 704a is closed off to the atmosphere while a second liquid flows into multi-channel chamber 702 through inlet channel 704b. Again, using a similar process already discussed, a predetermined amount of the second liquid is left behind in multi-channel chamber 702. The amount of the second liquid left behind may correspond to a difference between height  $h_2$  and  $h_1$  of opening 706b and 706a respectively.

15

20

25

**[0067]** It should be appreciated that although only two inlet channels are illustrated, any number of inlet channels may be realized to deliver liquids at various heights along the length of multi-channel chamber 702.

30

**[0068]** FIG. 8 illustrates a plurality of test chambers 216 as might be arranged in cartridge housing 102, according to another embodiment. Each test chamber 216 of the plurality includes an inlet channel 302. Each inlet channel 302 may

further connect to a fluidic network, such as, for example, the fluidic network around test cartridge 102.

[0069] A single pressure source (not shown) may be coupled to the system to flow liquid down each of the plurality of inlet channels 302. Thus, each of the plurality of test chambers 216 can be filled with the same pressure source. Additionally, during the application of a negative pressure, the same predetermined amount of fluid may be left behind in each of the plurality of test chambers 216. The same amount of fluid may be left in each test chamber 216 regardless of any geometrical differences between the various inlet channels 302, since each test chamber 216 is similarly pressurized. In another example, liquid may be pressurized into each channel up until a liquid sensing area disposed in each channel to set a pre-determined amount of liquid in each channel, before dosing the liquid down into test chambers 216.

[0070] FIG. 9 illustrates a plurality of test chambers, according to another embodiment. Instead of each inlet channel 901 coupling to a single chamber, each inlet channel 901 includes a fluidic splitter 902 to divide liquid flow into at least two split channels 903a-b. The at least two split channels 903a-b may then couple to at least two test chambers 904a-b. Although each inlet channel is depicted in FIG. 9 as splitting into two split channels 903a-b, it would be understood by one having one skill in the relevant art(s) given the description herein how to split any of the inlet channels 901 into any number of other channels. Each of split channels 903a-b may couple to respective test chambers 904a-b via opening 906a-b disposed along a length of the respective test chamber. In one example, each inlet channel 901 may further connect to a fluidic network.

[0071] Feeding multiple test chambers from a fewer number of inlet channels helps to ensure that each test chamber contains the same concentrations of the compounds present within the liquid. Furthermore, using a single inlet channel to dose multiple test chambers reduces the complexity of coupling a single pressure source to control the fluid flow to each chamber.

[0072] FIG. 10 illustrates an analyzer 1001 that operates to perform optical detection of compounds within test cartridge system 100, according to an

embodiment. Analyzer 1001 includes an optical probe 1002, a temperature control element 1004, a fan 1006, and a photodetector unit 1008 that includes an objective 1010.

5 [0073] Optical probe 1002 may be aligned over channel enlargement 214 to detect the presence of liquid within the respective channel chamber. Optical probe 1002 may use infrared or visible light wavelengths and include any number of detectors and transmitter components. Additionally, the data collected from optical probe 1002 may be used to control other components of analyzer 1001. For example, after optical probe 1002 has detected that liquid has  
10 been present for a certain threshold period of time, a signal may be sent to stop applying a positive pressure to the liquid and/or begin heating the contents of the test chambers of test cartridge system 100 using temperature control element 1004.

15 [0074] Temperature control element 1004 may be disposed near the test chambers along the bottom portion of test cartridge system 100. Temperature control element 1004 may contain components to heat and/or cool the contents of the test chambers. For example, temperature control element 1004 may be a Peltier device that applies thermoelectric heating or cooling. In another example, temperature control element 1004 is a resistive heater. Current may be  
20 passed through coils of wire or strips of metal printed on a surface to heat the surrounding area. In yet another example, temperature control element 1004 provides forced air to either heat or cool the test chambers. The forced air may be provided by fan 1006. In an embodiment, analyzer 1001 has temperature control elements on both sides of the test chambers. One temperature control  
25 element may be used for heating while the other is used for cooling, for example.

[0075] Photodetector unit 1008 may contain any type of optical detector known to those skilled in the relevant art(s) including, but not limited to, CCD arrays, photodiodes, and CMOS sensors. In one embodiment, photodetector unit 1008  
30 supplies an excitation wavelength of light to the test chambers and collects the emitted fluorescence light through objective 1010. In another embodiment, the excitation wavelength is supplied by another source (not shown). The emitted

fluorescence escapes the test chambers via optical access area 240 along the bottom portion of the test chambers.

[0076] FIG. 11 is a flow chart illustrating a chamber filling method 1100, according to an embodiment.

5 [0077] At block 1102, an initial amount of liquid flows down a first inlet channel. The first inlet channel may be, for example, connecting inlet 502 illustrated in FIG. 5.

[0078] At block 1104, the initial amount of liquid is split into a plurality of second inlet channels, with each of the second inlet channels coupled to a plurality of test chambers. In an embodiment, each of the plurality of test chambers has only one opening disposed along a length of the chamber for receiving one of the second inlet channels. A length of each test chamber may be aligned substantially parallel to a gravity vector.

10 [0079] At block 1106, each of the plurality of test chambers is filled with a final amount of liquid that is substantially equal in each of the test chambers. Additionally, the final amount of liquid in each test chamber sums to equal the initial amount of liquid.

[0080] Other actions may be considered as well as part of chamber filling method 1100. For example, chamber filling method 1100 may include re-suspending one or more reagents disposed in one or more of the plurality of test chambers in the final amount of liquid dosed into each of the test chambers. Another example action includes heating the contents within at least one of the plurality of test chambers. The heating may be performed by, for example, a Peltier device, a resistive heating element, and/or forced air. One or more optical properties of the contents within at least one of the plurality of test chambers may also be detected during chamber filling method 1100.

15 [0081] FIG. 12 is a flow chart illustrating a chamber filling method 1100, according to an embodiment.

[0082] At block 1202, liquid is flown through a plurality of inlet channels. Each of the inlet channels is coupled to a plurality of test chambers, according to an embodiment. A length of each test chamber is aligned substantially parallel to a gravity vector. In an embodiment, each of the plurality of test chambers has

20  
25  
30

only one opening disposed along the length of the chamber. In one example, the flowing through the plurality of inlet channels is performed via a single pump source.

5 [0083] At block 1204, each of the plurality of test chambers is filled with the liquid up to a threshold amount. In one example, the threshold amount is equal to or greater than a height at which the opening is disposed along the length of each of the test chambers.

10 [0084] At block 1206, the liquid is drawn away from each of the plurality of test chambers through the inlet channels, leaving behind a predetermined amount of the liquid within each test chamber. The predetermined amount of liquid may be an amount of liquid that is below the height at which the opening is disposed along the length of each of the test chambers. For example, the amount of liquid left in the chamber may be determined by the point at which the gravitational force and surface tension on the liquid overcome the negative pressure applied to the channel.

15 [0085] Other actions may be considered as well as part of chamber filling method 1200. For example, chamber filling method 1200 may include re-suspending one or more reagents disposed in one or more of the plurality of test chambers in the amount of the liquid left behind within the one or more test chambers. If reagents are re-suspended, then the drawing of liquid in block 20 1206 is performed quickly enough such that the drawn liquid does not contain the reagents. Another example action includes heating the contents within at least one of the plurality of test chambers. The heating may be performed by, for example, a Peltier device, a resistive heating element, and/or forced air. One 25 or more optical properties of the contents within at least one of the plurality of test chambers may also be detected during chamber filling method 1200.

[0086] FIG. 13 is a flow chart illustrating another chamber filling method 1200, according to an embodiment.

30 [0087] At block 1302, a first liquid flows through a first inlet channel. In an embodiment, the first inlet channel is coupled to a first opening disposed along a length of a test chamber at a first height. The length of the test chamber is aligned substantially parallel to a gravity vector. While the first liquid flows

through the first inlet channel at block 1302, a second inlet channel coupled to the test chamber is closed off to the atmosphere. In one example, both the first and second inlet channels are open to the atmosphere to start with.

5 [0088] At block 1304, the test chamber is filled with the first liquid up to a first threshold amount. In one example, the first threshold amount is equal to or greater than the first height of the first opening of the test chamber.

10 [0089] At block 1306, the first liquid is drawn away from the test chamber through the first inlet channel, leaving behind a first predetermined amount of liquid within the test chamber. The first predetermined amount of liquid may be an amount of liquid that corresponds to the first height of the first opening of the test chamber. For example, the amount of liquid left in the chamber may be determined by the point at which the gravitational force and surface tension on the liquid overcome the negative pressure applied to the first channel.

15 [0090] At block 1308, the first inlet channel is closed off to the atmosphere and the second inlet channel is opened, according to an embodiment. The switching of the active channel may be performed via one or more valves coupled to the fluidic network.

20 [0091] At block 1310, a second liquid flows through a second inlet channel. In an embodiment, the second inlet channel is coupled to a second opening disposed along the length of the test chamber at a second height that is greater than the first height. In one example, the flowing of both the first liquid in block 1302 and the second liquid in block 1308 is performed via a single pump source.

[0092] At block 1312, the test chamber is filled with the second liquid up to a second threshold amount.

25 [0093] At block 1314, the second liquid is drawn away from the test chamber through the second inlet channel, leaving behind a second predetermined amount of liquid within the test chamber. In one example, the second predetermined amount of liquid is an amount of liquid that corresponds to the difference between the second height of the second opening and the first height of the first opening of the test chamber. In another example, the amount of liquid left in the chamber may be determined by the point at which the gravitational force and

30

surface tension on the liquid overcome the negative pressure applied to the second channel.

[0094] Similarly to chamber filling method 1200, other actions may be considered as part of chamber filling method 1300. For example, chamber filling  
5 method 1300 may include re-suspension of one or more reagents disposed within the test chamber in the predetermined amount of the first and second liquids left behind in the test chamber. Alternatively, the one or more reagents may be re-suspended in only the first liquid left behind in the test chamber. In one example, any reagents that may be present within the test chamber are not  
10 drawn back into either the first or second inlet channel in blocks 1306 and 1314 respectively. Chamber filling method 1300 may further include heating the contents of the test chamber and/or detecting one or more optical properties of the contents of the test chamber as described previously in regards to chamber filling method 1200. Although only two inlet channels are described in chamber  
15 filling method 1300, it should be appreciated that chamber filling method 1300 may be expanded to include any number of inlet channels into one or more chambers.

[0095] FIG. 14 is a flow chart illustrating another chamber filling method 1400, according to an embodiment.

20 [0096] At block 1402, a liquid flows through each of a plurality of channels up to a liquid sensing area disposed in each channel, according to an embodiment. The liquid may be pressurized to flow down each channel, and may be flown down each channel separately or simultaneously. Flowing the liquid up to the sensing area sets a pre-determined amount of liquid within each of the plurality  
25 of channels, according to an embodiment.

[0097] At block 1404, the pre-determined amount of liquid within each of the plurality of channels flows into respective chambers coupled to each of the channels, according to an embodiment. Each channel may be separately or simultaneously pressurized to force the pre-determined amount of liquid down  
30 into each corresponding chamber.

[0098] Method 1400 may also include re-suspending one or more reagents disposed in one or more channels of the plurality of channels. The reagents may be disposed within premixing chambers coupled to each of the channels.

5 [0099] The foregoing description of the specific embodiments will so fully reveal the general nature of the invention that others can, by applying knowledge within the skill of the art, readily modify and/or adapt for various applications such specific embodiments, without undue experimentation, without departing from the general concept of the present invention. Therefore, such adaptations and modifications are intended to be within the meaning and range of  
10 equivalents of the disclosed embodiments, based on the teaching and guidance presented herein. It is to be understood that the phraseology or terminology herein is for the purpose of description and not of limitation, such that the terminology or phraseology of the present specification is to be interpreted by the skilled artisan in light of the teachings and guidance.

15 [00100] Embodiments of the present invention have been described above with the aid of functional building blocks illustrating the implementation of specified functions and relationships thereof. The boundaries of these functional building blocks have been arbitrarily defined herein for the convenience of the description. Alternate boundaries can be defined so long as the specified  
20 functions and relationships thereof are appropriately performed.

[00101] The Summary and Abstract sections may set forth one or more but not all exemplary embodiments of the present invention as contemplated by the inventor(s), and thus, are not intended to limit the present invention and the appended claims in any way.

25 [00102] The breadth and scope of the present invention should not be limited by any of the above-described exemplary embodiments, but should be defined only in accordance with the following claims and their equivalents.

## WHAT IS CLAIMED IS:

1. A fluidic testing system, comprising:
  - 5 a plurality of test chambers, each characterized by a length and a hydraulic diameter, wherein each of the plurality of test chambers has only one opening disposed along the length of the corresponding test chamber;
  - a first inlet channel configured to flow an initial amount of liquid from an inlet port, wherein the inlet port is the only external opening to the fluidic testing system; and
  - 10 a plurality of fluid splitting elements configured to split the initial liquid flowing down the first inlet channel into a plurality of second inlet channels, wherein each of the plurality of test chambers is coupled via its respective opening to only one of the plurality of second inlet channels.
2. The fluidic testing system of claim 1, wherein the length of each test chamber is configured to be aligned substantially parallel to a gravity vector.
- 15 3. The fluidic testing system of claim 1 or 2, further comprising a plurality of liquid sensing areas disposed along the plurality of second inlet channels.
4. The fluidic testing system of claim 3, wherein each of the plurality of liquid sensing areas is configured to monitor the presence of liquid within a corresponding test chamber.
- 20 5. The fluidic testing system of claim 3 or 4, wherein each of the plurality of liquid sensing areas is configured to dose a pre-determined amount of liquid into a corresponding test chamber.
6. The fluidic testing system of any of the previous claims, wherein at least one of the plurality of test chambers includes one or more reagents.
- 25 7. The fluidic testing system of claim 6, wherein the one or more reagents are freeze-dried pellets disposed within the test chambers.

8. The fluidic testing system of any of the previous claims, further comprising a plurality of premixing chambers disposed along the plurality of second inlet channels.
9. The fluidic testing system of claim 8, wherein the plurality of premixing chambers comprise one or more reagents.
10. The fluidic testing system of any of the previous claims, wherein a bottom wall of each of the plurality of test chambers has a curved geometry.
11. The fluidic testing system of any of the previous claims, wherein the bottom wall of each of the plurality of test chambers is transparent to allow for optical interrogation.
12. The fluidic testing system of any of the previous claims, wherein a single pump is configured to force an initial amount of liquid through the first inlet channel and fill each of the plurality of test chambers with an equal portion of the initial amount of liquid.
13. The fluidic testing system of any of the previous claims, wherein one or more walls of the plurality of chambers is in contact with a thermally controlled housing.
14. The fluidic testing system of claim 13, wherein the one or more walls are polymeric films having a thickness less than 100 microns.
15. The fluidic testing system of claim 13 or 14, wherein the one or more walls have a thermal conductivity greater than 1 W/mK.
16. The fluidic testing system of any of claims 13-15, wherein the thermally controlled housing comprises a Peltier device.
17. The fluidic testing system of any of claims 13-16, wherein the thermally controlled housing comprises electrical resistive heating elements.

18. The fluidic testing system of any of claims 13-17, wherein the thermally controlled housing is heated via forced air.
19. A method comprising:
- flowing an initial amount of liquid down a first inlet channel of a single-  
5 port fluidic testing system;
- splitting the initial amount of liquid from the first inlet channel into a  
plurality of second inlet channels, each second inlet channel coupled to a  
plurality of test chambers, wherein each of the plurality of test chambers has  
only one opening disposed along a length of the chamber; and
- 10 style="padding-left: 40px;">filling each of the plurality of test chambers with a final amount of  
liquid, the final amount being substantially equal in each of the test chambers  
and summing from each test chamber to equal the initial amount of liquid.
20. The method of claim 19, wherein the length of each test chamber is configured to be aligned substantially parallel to a gravity vector.
- 15 21. The method of claim 19 or 20, further comprising re-suspending one or more reagents disposed in one or more of the plurality of test chambers in the final amount of liquid.
22. The method of any of claims 19-21, further comprising re-suspending one or more reagents disposed in one or more of a plurality of premixing chambers in  
20 the final amount of liquid.
23. The method of any of claims 19-22, further comprising heating the contents within at least one of the plurality of test chambers.
24. The method of claim 23, wherein the heating comprises heating with a Peltier device.
- 25 25. The method of claim 23 or 24, wherein the heating comprises heating with resistive heating elements.

26. The method of any of claims 23-25, wherein the heating comprises heating with forced air.
27. The method of any of claims 19-26, further comprising detecting one or more optical properties of the contents within at least one of the plurality of test chambers.
- 5 28. The method of any of claims 19-27, wherein the flowing, splitting, and filling are performed via a single pump source.
29. A fluidic testing system, comprising:
- 10 a plurality of test chambers, each characterized by a length and a hydraulic diameter, wherein the length of each test chamber is configured to be aligned substantially parallel to a gravity vector, and wherein each of the plurality of test chambers has only one opening disposed along the length of the corresponding test chamber;
  - 15 a plurality of inlet channels, wherein each of the plurality of test chambers is coupled via its respective opening to only one of the plurality of inlet channels; and
  - a fluidic network configured to connect the plurality of inlet channels to one or more other chambers.
- 20 30. The fluidic testing system of claim 29, further comprising a plurality of liquid sensing areas disposed along the plurality of inlet channels.
31. The fluidic testing system of claim 30, wherein each of the plurality of liquid sensing areas is configured to monitor the presence of liquid within a corresponding test chamber.
- 25 32. The fluidic testing system of claim 30 or 31, wherein each of the plurality of liquid sensing areas is configured to dose a pre-determined amount of liquid into a corresponding test chamber.
33. The fluidic testing system of any of claims 29-32, wherein the position of the only one opening along the length of the corresponding test chamber controls the

amount of liquid that remains within the respective chamber after the remainder of the liquid is drawn away from the opening through the respective inlet channel.

- 5 34. The fluidic testing system of any of claims 29-33, wherein the width of the only one opening is larger than the width of the respective inlet channel.
35. The fluidic testing system of any of claims 29-34, wherein at least one of the plurality of test chambers includes one or more reagents.
36. The fluidic testing system of claim 35, wherein the one or more reagents are freeze-dried pellets disposed within the test chambers.
- 10 37. The fluidic testing system of any of claims 29-36, further comprising a plurality of premixing chambers disposed along the plurality of second inlet channels.
38. The fluidic testing system of claim 37, wherein the plurality of premixing chambers comprise one or more reagents.
- 15 39. The fluidic testing system of any of claims 29-38, wherein a bottom wall of each of the plurality of test chambers has a curved geometry.
40. The fluidic testing system of any of claims 29-39, wherein the bottom wall of each of the plurality of test chambers is transparent to allow for optical interrogation.
- 20 41. The fluidic testing system of any of claims 29-40, wherein a single pump is used to force liquid through the plurality of inlet channels.
42. The fluidic testing system of any of claims 29-41, wherein one or more walls of the plurality of chambers is in contact with a thermally controlled housing.
43. The fluidic testing system of claim 42, wherein the one or more walls are polymeric films having a thickness less than 100 microns.
- 25 44. The fluidic testing system of claim 42 or 43, wherein the one or more walls have a thermal conductivity greater than 1 W/mK.

45. The fluidic testing system of any of claims 42-44, wherein the thermally controlled housing comprises a Peltier device.
46. The fluidic testing system of any of claims 42-45, wherein the thermally controlled housing comprises electrical resistive heating elements.
- 5 47. The fluidic testing system of any of claims 42-46, wherein the thermally controlled housing is heated via forced air.
48. The fluidic testing system of any of claims 29-47, wherein at least one of the plurality of inlet channels is coupled to more than one opening.
49. A method comprising:
- 10           flowing liquid through a plurality of inlet channels, each inlet channel coupled to a plurality of test chambers, wherein a length of each test chamber is configured to be aligned substantially parallel to a gravity vector, and wherein each of the plurality of test chambers has only one opening disposed along the length of the chamber;
- 15           filling each of the plurality of test chambers with the liquid up to a threshold amount;
- drawing the liquid away from each of the plurality of test chambers through the inlet channels, wherein the drawing leaves behind a predetermined amount of the liquid within each test chamber.
- 20 50. The method of claim 49, further comprising re-suspending one or more reagents disposed in one or more of the plurality of test chambers in the amount of the liquid left behind within the one or more test chambers.
51. The method of claim 50, wherein the drawing draws liquid that does not contain the reagents.
- 25 52. The method of any of claims 49-51, wherein filling up to the threshold amount comprises filling each of the test chambers up to a height equal to or greater than a height at which the opening is disposed along the length of each of the test chambers.

53. The method of claim 52, wherein leaving behind a predetermined amount of the liquid comprises leaving an amount of the liquid that is below the height at which the opening is disposed along the length of each of the test chambers.
54. The method of any of claims 49-53, further comprising heating the contents within at least one of the plurality of test chambers.
55. The method of claim 54, wherein the heating comprises heating with a Peltier device.
56. The method of claim 54 or 55, wherein the heating comprises heating with resistive heating elements.
57. The method of any of claims 54-56, wherein the heating comprises heating with forced air.
58. The method of any of claims 49-57, further comprising detecting one or more optical properties of the contents within at least one of the plurality of test chambers.
59. The method of any of claims 49-58, wherein the flowing is performed via a single pump source.
60. A method comprising:
- flowing a first liquid through a first inlet channel coupled to a first opening disposed along a length of a test chamber at a first height, wherein the length of the test chamber is configured to be aligned substantially parallel to a gravity vector;
  - filling the test chamber with the first liquid up to a first threshold amount;
  - drawing the first liquid away from the test chamber through the first inlet channel, wherein the drawing leaves behind a first predetermined amount of the first liquid within the test chamber;

flowing a second liquid through a second inlet channel coupled to a second opening disposed along the length of the test chamber at a second height, wherein the second height is greater than the first height;

5 filling the test chamber with the second liquid up to a second threshold amount;

drawing the second liquid away from the test chamber through the second inlet channel, wherein the drawing leaves behind a second predetermined amount of the second liquid within the test chamber.

10 61. The method of claim 60, wherein leaving behind a first predetermined amount of the first liquid, comprises leaving behind an amount of the first liquid that corresponds to the first height of the first opening.

15 62. The method of claim 60 or 61, wherein leaving behind a second predetermined amount of the second liquid comprises leaving behind an amount of the second liquid that corresponds to a difference between the second height of the second opening and the first height of the first opening.

63. The method of any of claims 60-62, further comprising re-suspending one or more reagents disposed in the test chamber in the predetermined amount of the first and second liquid left behind within the test chamber.

20 64. The method of any of claims 60-63, further comprising re-suspending one or more reagents disposed in the test chamber in the predetermined amount of only the first liquid left behind within the test chamber.

65. The method of claim 63 or 64, wherein the drawing of either the first or second liquid draws liquid that does not contain any of the reagents.

25 66. The method of any of claims 60-65, further comprising heating the contents within the test chamber.

67. The method of claim 66, wherein the heating comprises heating with a Peltier device.

68. The method of claim 66 or 67, wherein the heating comprises heating with resistive heating elements.
69. The method of any of claims 66-68, wherein the heating comprises heating with forced air.
- 5 70. The method of any of claims 60-69, further comprising detecting one or more optical properties of the contents within the test chamber.
71. The method of any of claims 60-70, wherein the flowing of the first and second liquid is performed via a single pump source.
72. The method of any of claims 60-71, further comprising, after the drawing of the  
10 first liquid, closing off the first inlet channel from the atmosphere.
73. A method comprising:
- flowing liquid through each of a plurality of channels up to a liquid sensing area disposed in each channel, thus setting a pre-determined amount of liquid within each of the plurality of channels;
- 15 flowing only the pre-determined amount of liquid within each of the plurality of channels into respective chambers coupled to each of the channels.
74. The method of claim 73, further comprising re-suspending one or more reagents disposed in one or more channels of the plurality of channels.
75. The method of claim 74, wherein re-suspending one or more reagents comprises  
20 re-suspending one or more reagents disposed within premixing chambers coupled to the one or more channels.

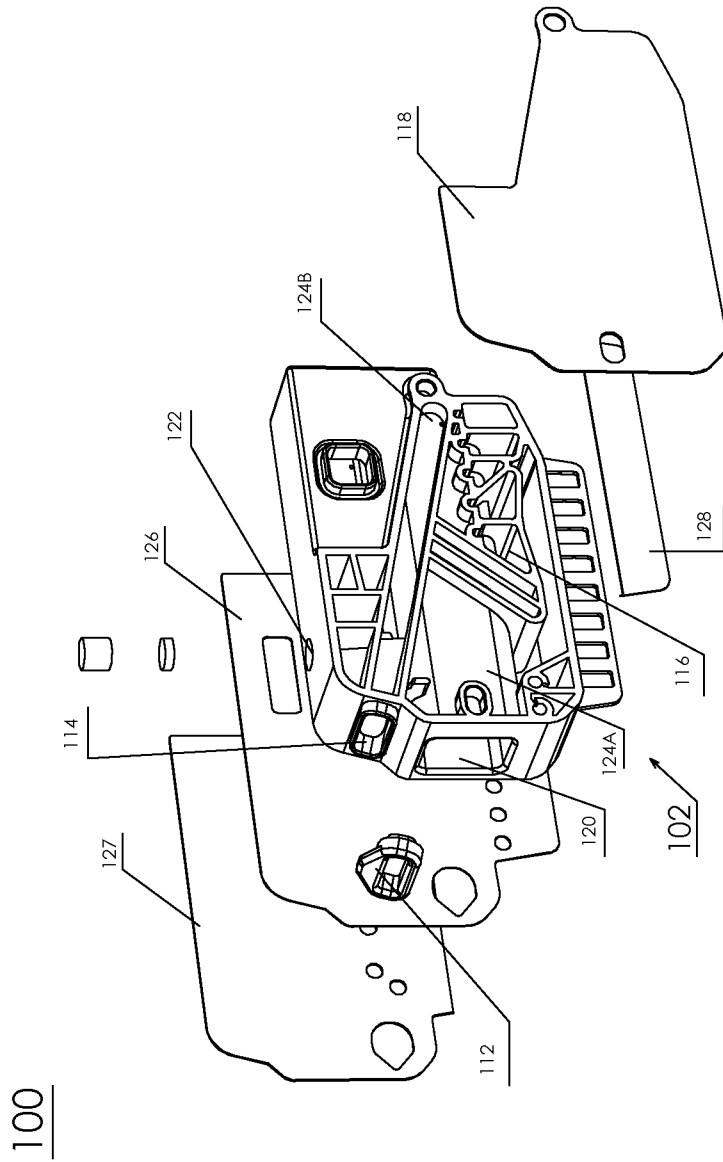

Fig. 1

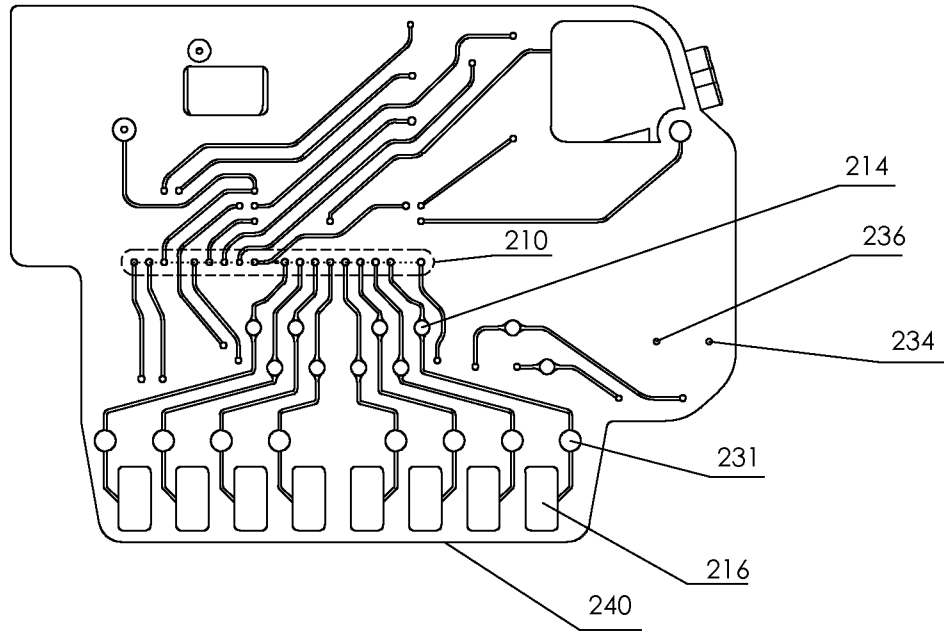

Fig. 2

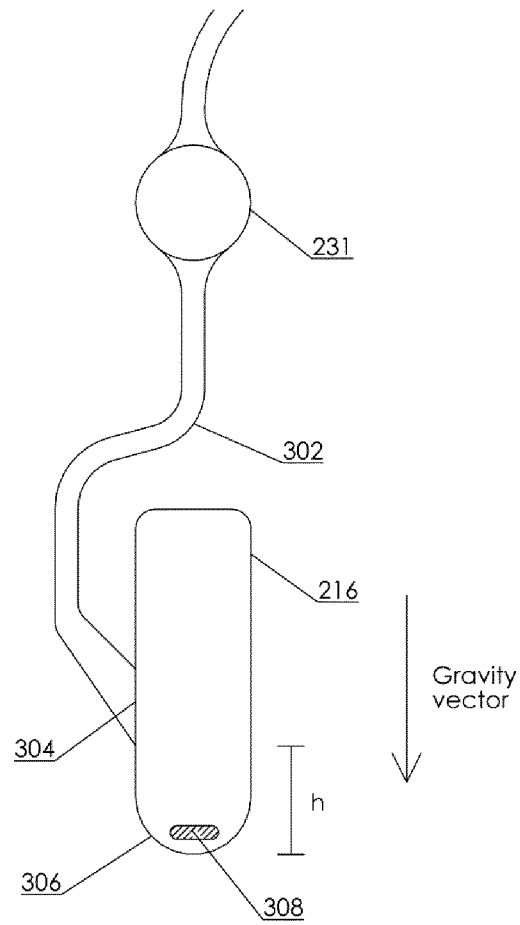

Fig. 3

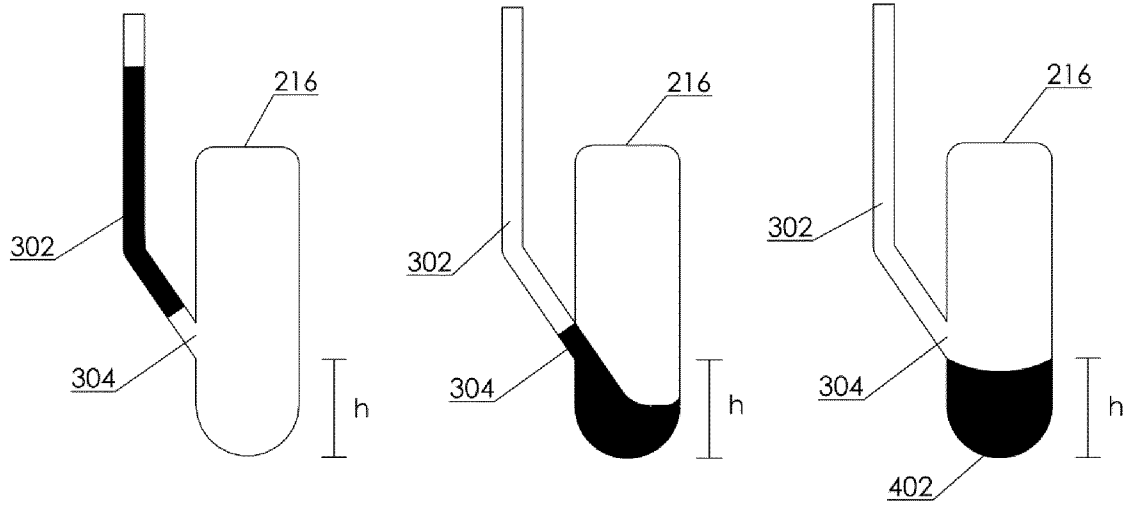

Fig. 4A

Fig. 4B

Fig. 4C



Fig. 5

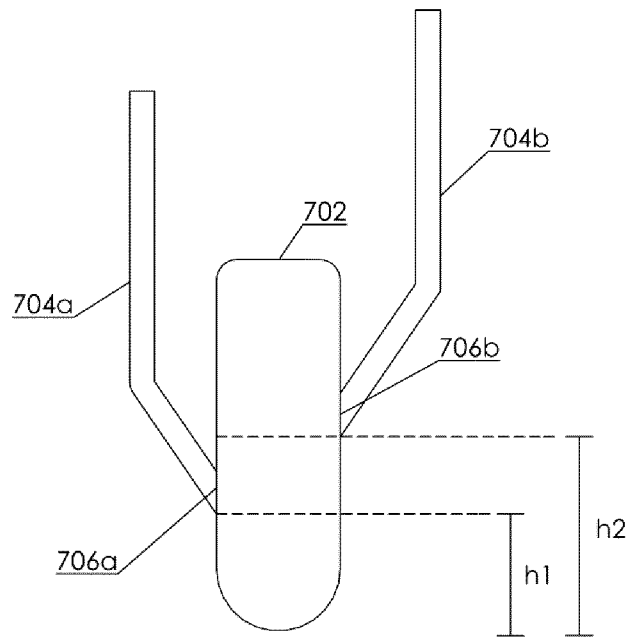
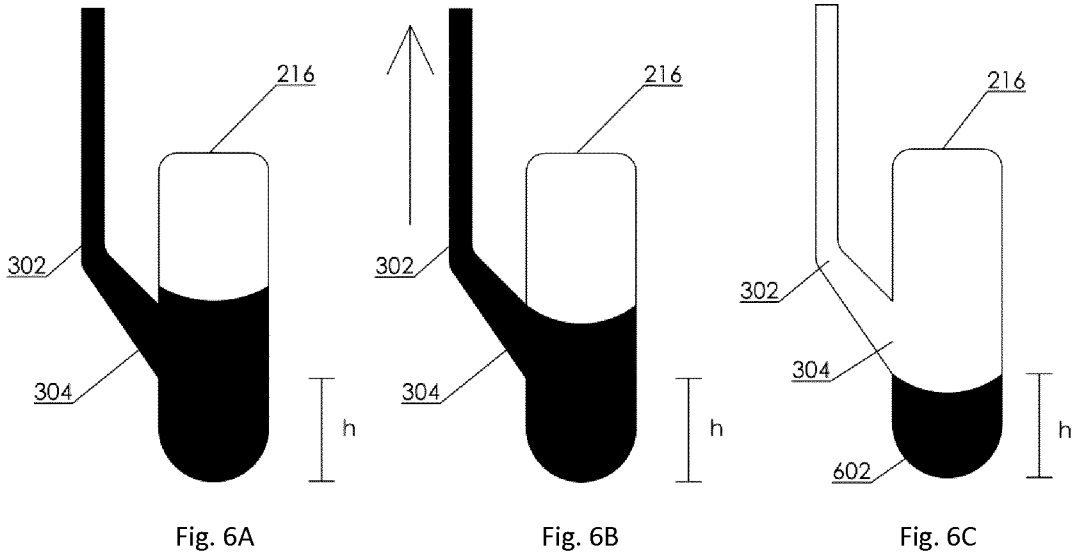

6/11

To Fluidic Network

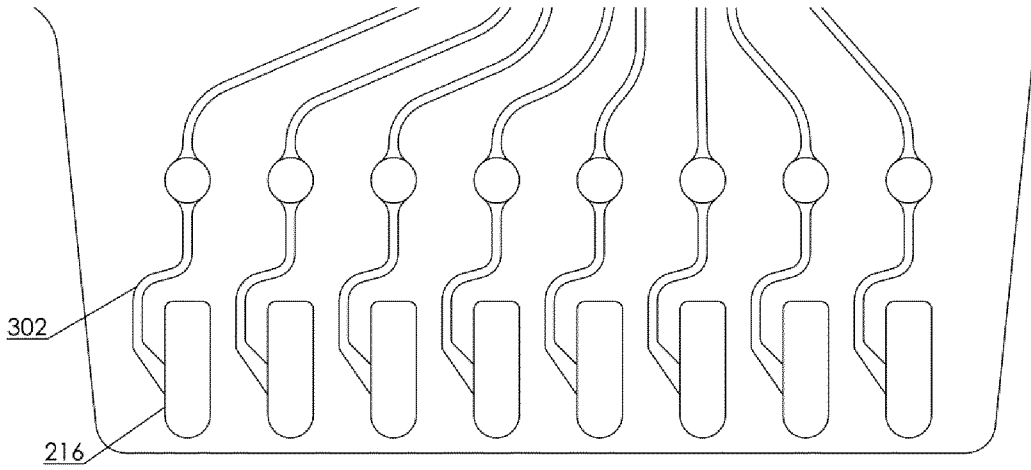

Fig. 8

To Fluidic Network

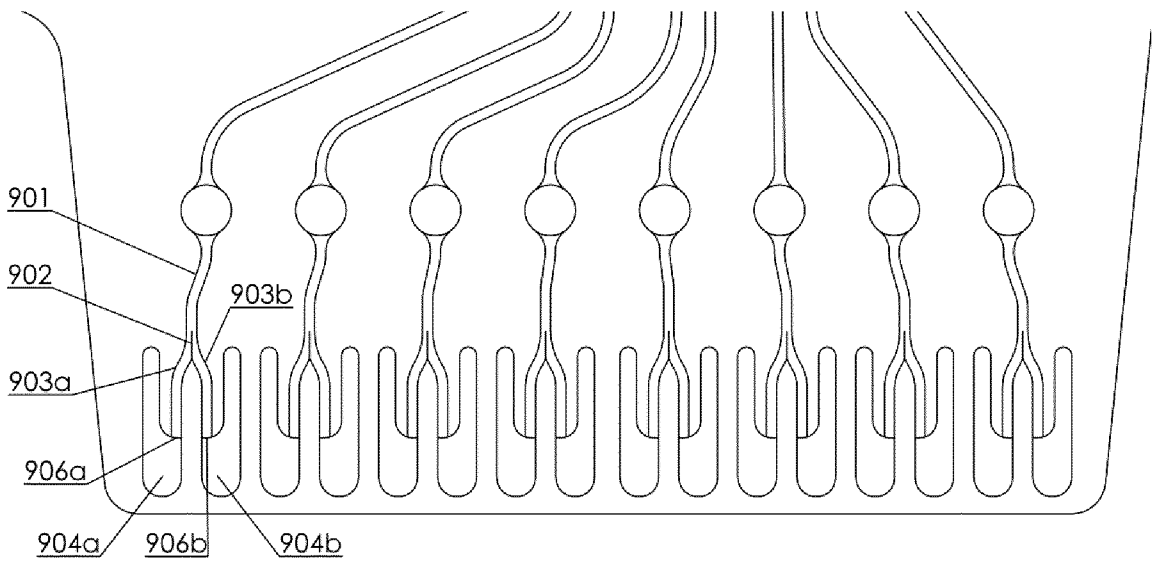

Fig. 9

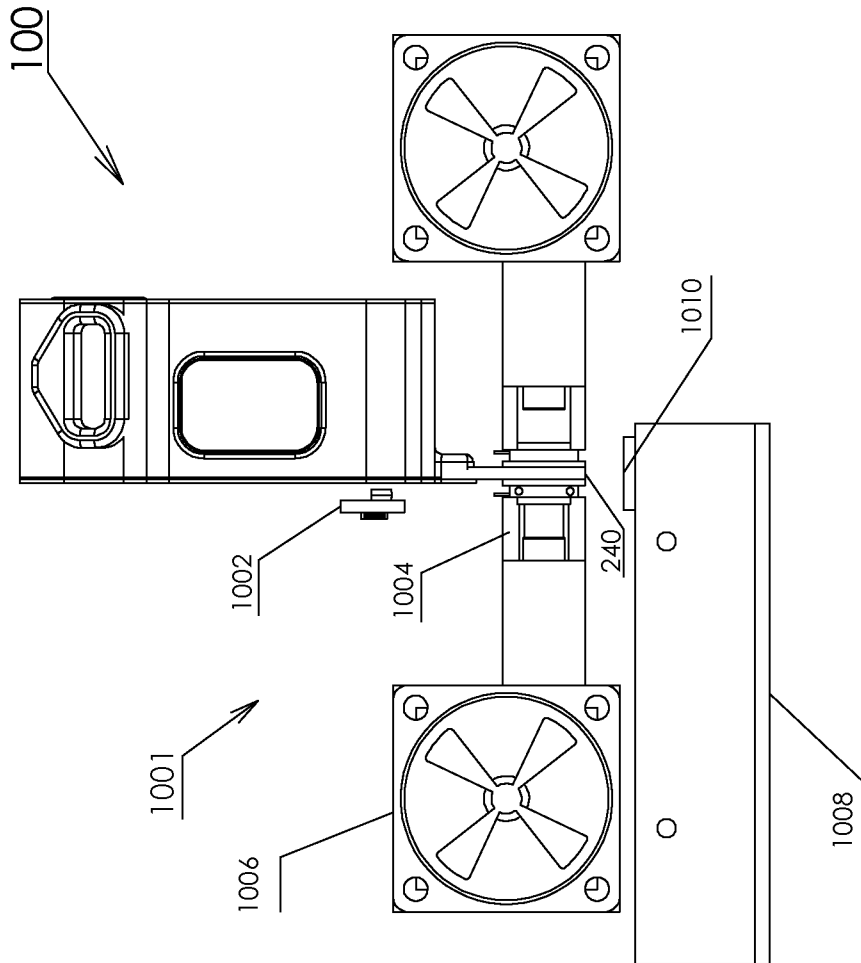

Fig. 10

1100

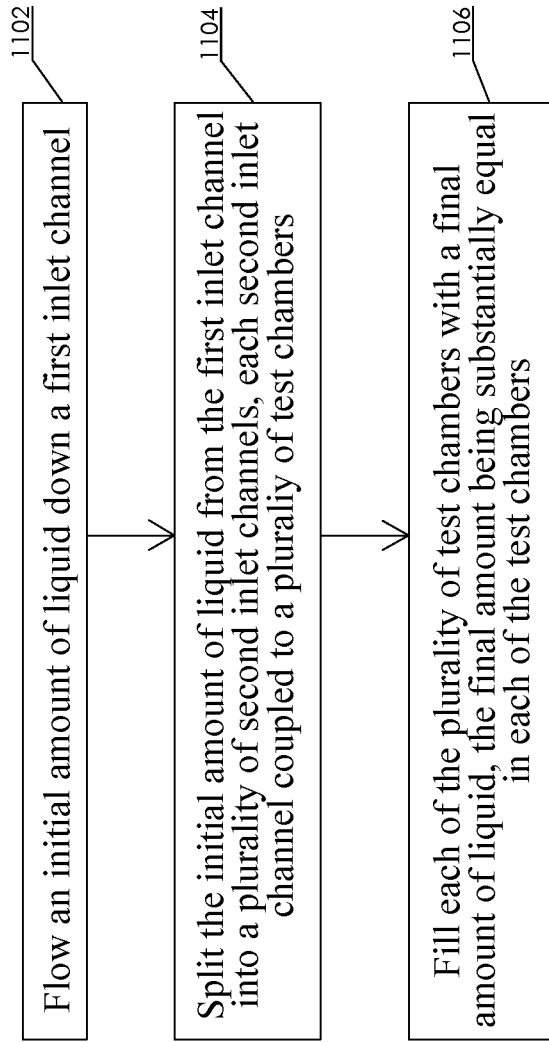

Fig. 11

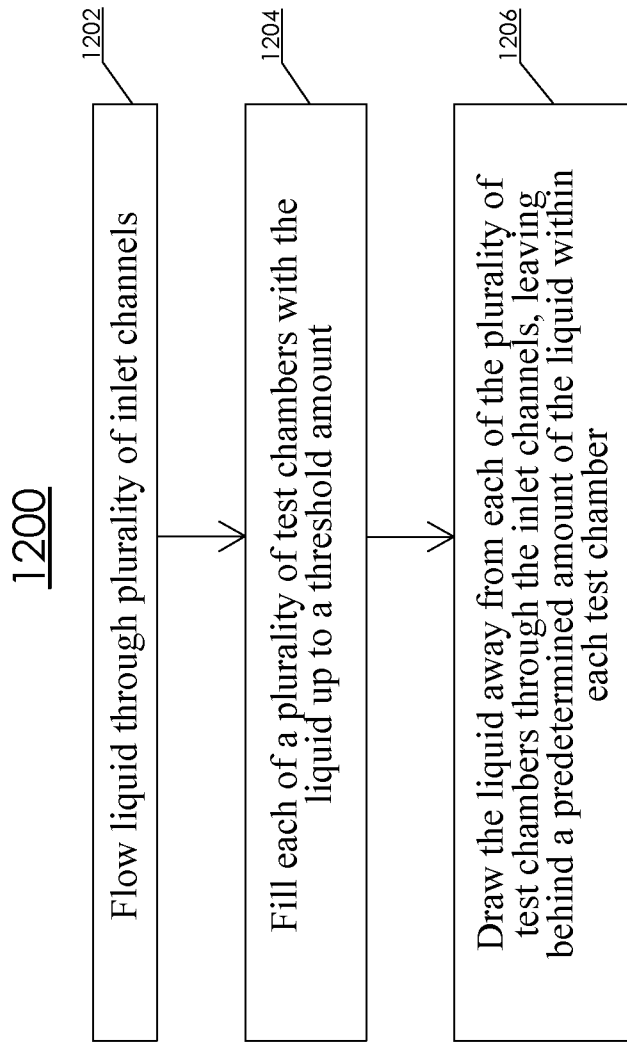

Fig. 12

10/11

1300

Fig. 13

1400

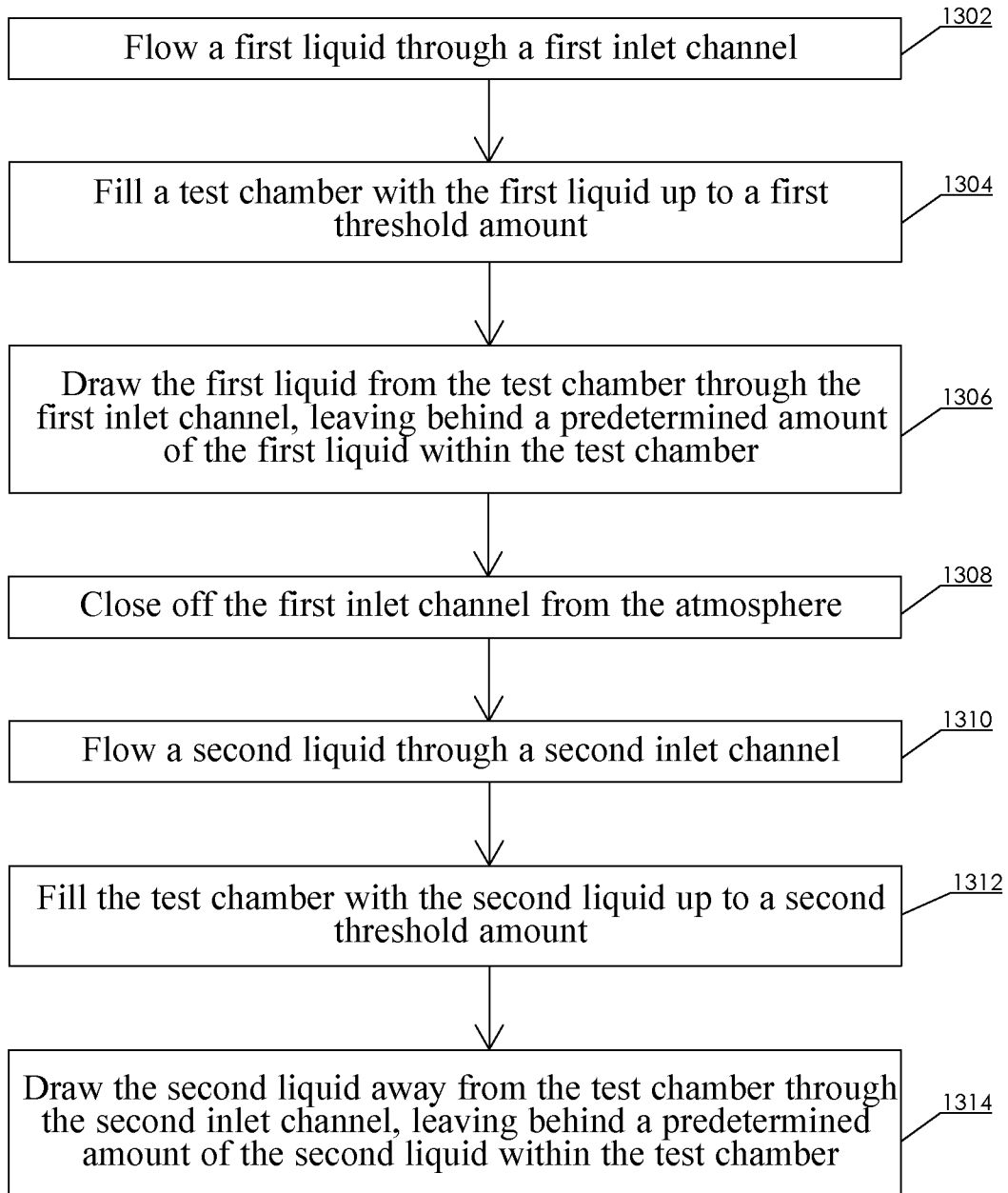
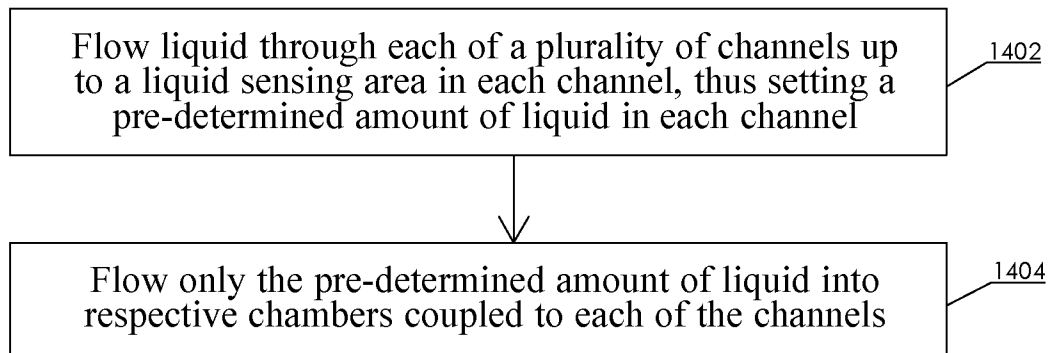

Fig. 14